

HCD710A, HMD710A Horizon Elite™ Ice Machines (Self-contained)

Order parts online
www.follettice.com

Operation and Service Manual
Serial Numbers L60417 to R03745

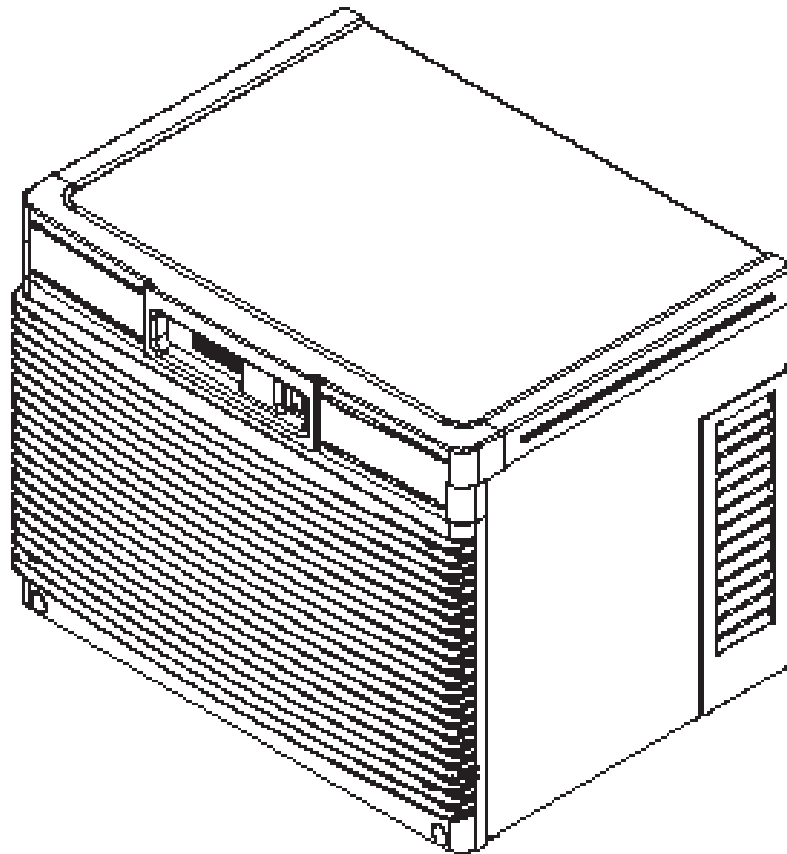

801 Church Lane • Easton, PA 18040, USA
Toll free (877) 612-5086 • +1 (610) 252-7301
www.follettice.com

01223080R08

Contents

Welcome to Follett	3
Before you begin	3
Specifications	4
Operation.	7
Preventive maintenance	7
Weekly exterior care	7
Monthly condenser cleaning (air-cooled icemaker only)	7
Semi-annual evaporator cleaning (every 6 months)	7
Service	11
Harvest system diagram	11
Water system diagram	13
Water level diagram	13
Normal control board operation	14
DIP Switch Settings	14
Error faults:	15
Soft errors:	15
Hard error:.	15
Run errors:	15
Relay output indication:	15
Evaporator flushing sequence:	15
Wiring diagram	16
Mechanical System	18
Reservoir/rear bushing disassembly	25
Refrigerant pressure data	26
Refrigeration system diagram.	26
Evacuation	27
Ice capacity test	27
Troubleshooting	28
Replacement parts	30

Welcome to Follett

Follett equipment enjoys a well-deserved reputation for excellent performance, long-term reliability and outstanding after-the-sale support. To ensure that this equipment delivers the same degree of service, we ask that you review the installation manual (provided as a separate document) before beginning to install the unit. Our instructions are designed to help you achieve a trouble-free installation. Should you have any questions or require technical help at any time, please call our technical service group at (877) 612-5086 or +1 (610) 252-7301.

Before you begin

After uncrating and removing all packing material, inspect the equipment for concealed shipping damage. If damage is found, notify the shipper immediately and contact Follett LLC so that we can help in the filing of a claim, if necessary.

Check your paperwork to determine which model you have. Follett model numbers are designed to provide information about the type and capacity of Follett equipment. Following is an explanation of the different model numbers in the series.

Chewblet® Ice Machine Model Number Configurations

Icemaker	Voltage	Series	Condenser	Application	Configuration
MC Maestro™ Chewblet® (425 Series) HC Horizon Chewblet (710, 1010, 1410, 1810, 2110 Series) HM Horizon Micro Chewblet	C 208-230/60/1 (icemaking head) <i>Self-contained only.</i> D 115/60/1 (icemaking head) <i>Self-contained and remote. If remote unit, high side is 208-230/60/1.</i> E 230/50/1 (icemaking head) <i>Self-contained only.</i> F 115/60/1 (icemaking head) <i>Remote only. High side is 208-230/60/3.</i>	425 up to 425 lbs (193 kg) 710 up to 675 lbs (306 kg) 1010 up to 1061 lbs (482 kg) 1410 up to 1466 lbs (665 kg) 1810 up to 1790 lbs (812 kg) 2110 up to 2039 lbs (925 kg)	A Air-cooled, self-contained W Water-cooled, self-contained R Air-cooled, remote condensing unit N Air-cooled, no condensing unit for connection to parallel rack system	V Vision™ H Harmony™ B Ice storage bin J Drop-in M Ice Manager diverter valve system P Cornelius Profile PR150	S RIDE™ (RIDE remote ice delivery equipment) T Top-mount

CAUTION

- Warranty does not cover exterior or outside installations.
- Moving parts. Do not operate with front cover removed.
- Hot parts. Do not operate with cover removed.
- To reduce risk of shock, disconnect power before servicing.
- Drain line must not be vented.
- Water supply must have particle filtration.
- Most ice machine cleaners contain citric or phosphoric acid, which can cause skin irritation. Read caution label on product and follow instructions carefully.
- Ice is slippery. Maintain counters and floors around dispenser in a clean and ice-free condition.
- Ice is food. Follow recommended cleaning instructions to maintain cleanliness of delivered ice.

Specifications

Electrical

Each ice machine requires its own separate circuit with electrical disconnect within 10 ft (6m).
Equipment ground required.

Standard electrical:

- 115 V/60/1 (6 ft (2m) NEMA 5-15 cord and plug provided)
- Amperage: 11.3A, dedicated 15A circuit required

Plumbing

WARNING

This equipment to be installed with adequate backflow protection to comply with applicable federal, state, and local codes.

- 3/8" OD push-in water inlet (connection inside machine) - 3/8" OD tubing required
- 3/4" MPT drain

Notes:

- Water shut-off recommended within 10 feet (3m).
- Water supply must have particle filtration. Follett recommends the filter system that has integral scale inhibitors. (Follett item# 00130286).
- Follett does not recommend the use of water softeners or bowl scale inhibitors.

Drain plumbing

- 3/4" MPT drain connection at the rear of the machine.
- Drain must slope 1/4" inch per foot (6 mm per 30.4 cm).
- Drain line should not be shared with any other piece of equipment.
- Drain line cannot be reduced to a size smaller than 1 inch.
- Drain should be piped without a vent.

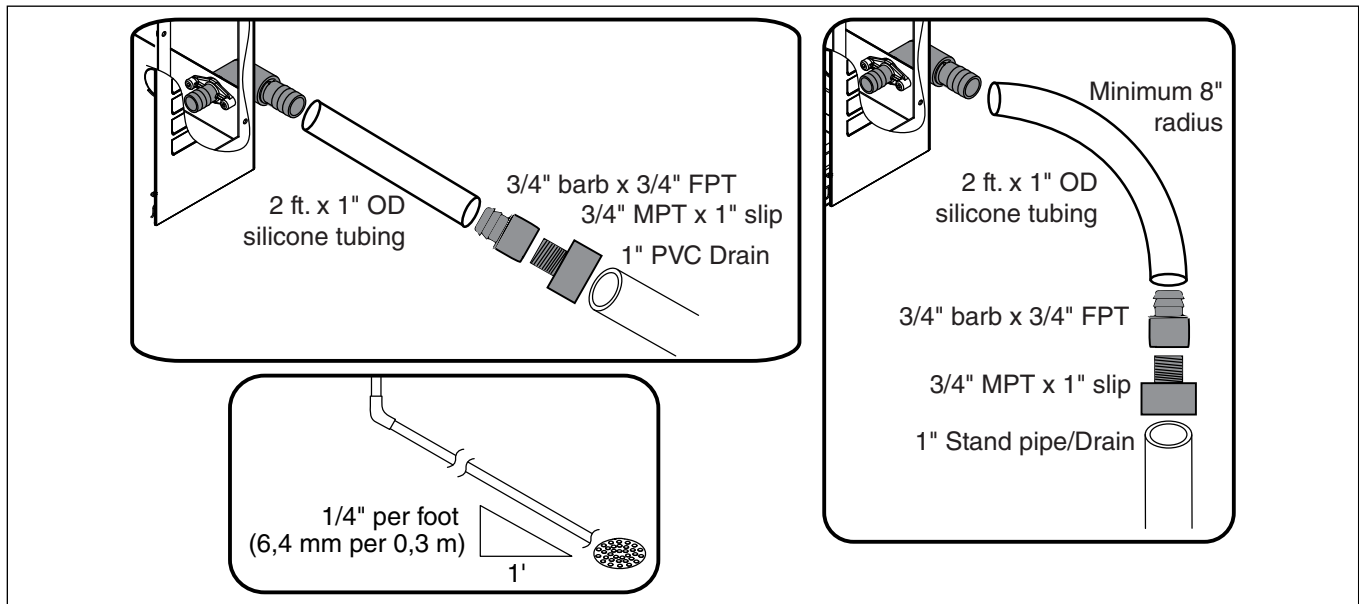

Chassis drain plumbing

- Plug must be removed from John Guest fitting.
- Route 3/8" drain tubing through knockout in back of docking station and insert fully into John Guest fitting connection at the rear of the machine chassis. Route other end of 3/8" drain tubing to drain.
- Drain must slope 1/4" per foot (6 mm per 30,4 cm).

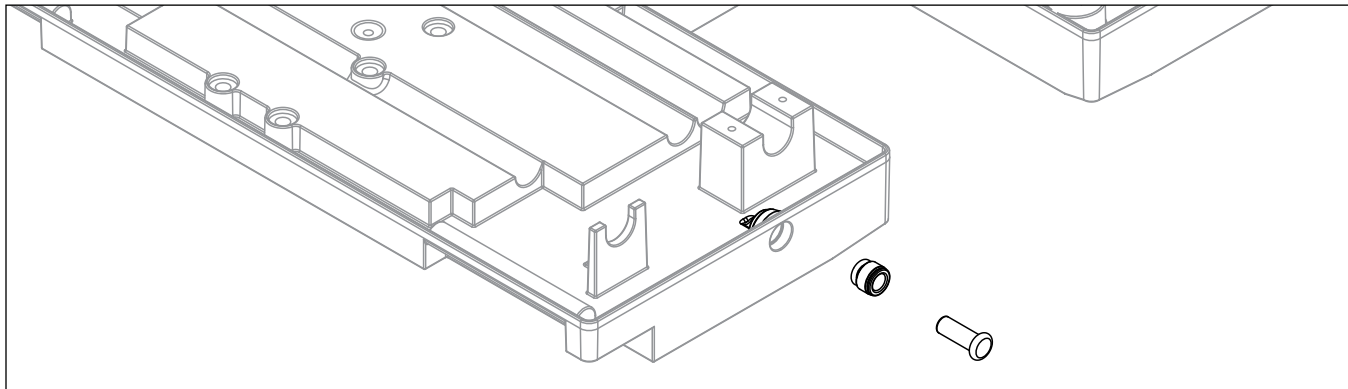

Ambient

Air temperature	100 F/38 C max.	50 F/10 C min.
Water temperature	90 F/32 C max.	45 F/7 C min.
Water pressure – potable	70 psi max. (483 kPa)	10 psi min. (89 kPa)

Heat rejection

	710
Air-cooled	8,500 BTU/hr

Ice production

710 Air-cooled ice machine capacity/24 hrs.

Ambient Air Temperature F/C							
Evap Potable Water Temperature F/C	F	60	70	80	90	100	
	C	16	21	27	32	38	
	50	787	759	705	639	603	lbs
	10	357	344	320	290	274	kg
	60	750	702	666	624	570	lbs
	16	340	318	302	283	259	kg
	70	707	681	636	586	542	lbs
	21	321	309	288	266	246	kg
	80	677	629	611	559	518	lbs
	27	307	285	277	254	235	kg
	90	642	600	580	539	497	lbs
	32	291	272	263	244	225	kg

Weight

Shipping	190 lb (86.2 kg)
Net	170 lb (77.2 kg)

Dimensions and clearances

- Entire front of ice machine must be clear of obstructions/connections to allow removal.
- 1" (26 mm) clearance above ice machine for service.
- 1" (26 mm) minimum clearance on sides.
- The intake and exhaust air grilles must provide at least 250 sq in (1615 sq cm) of open area.
- Air-cooled ice machines – 18" (458 mm) minimum clearance between discharge and air intake-grilles.

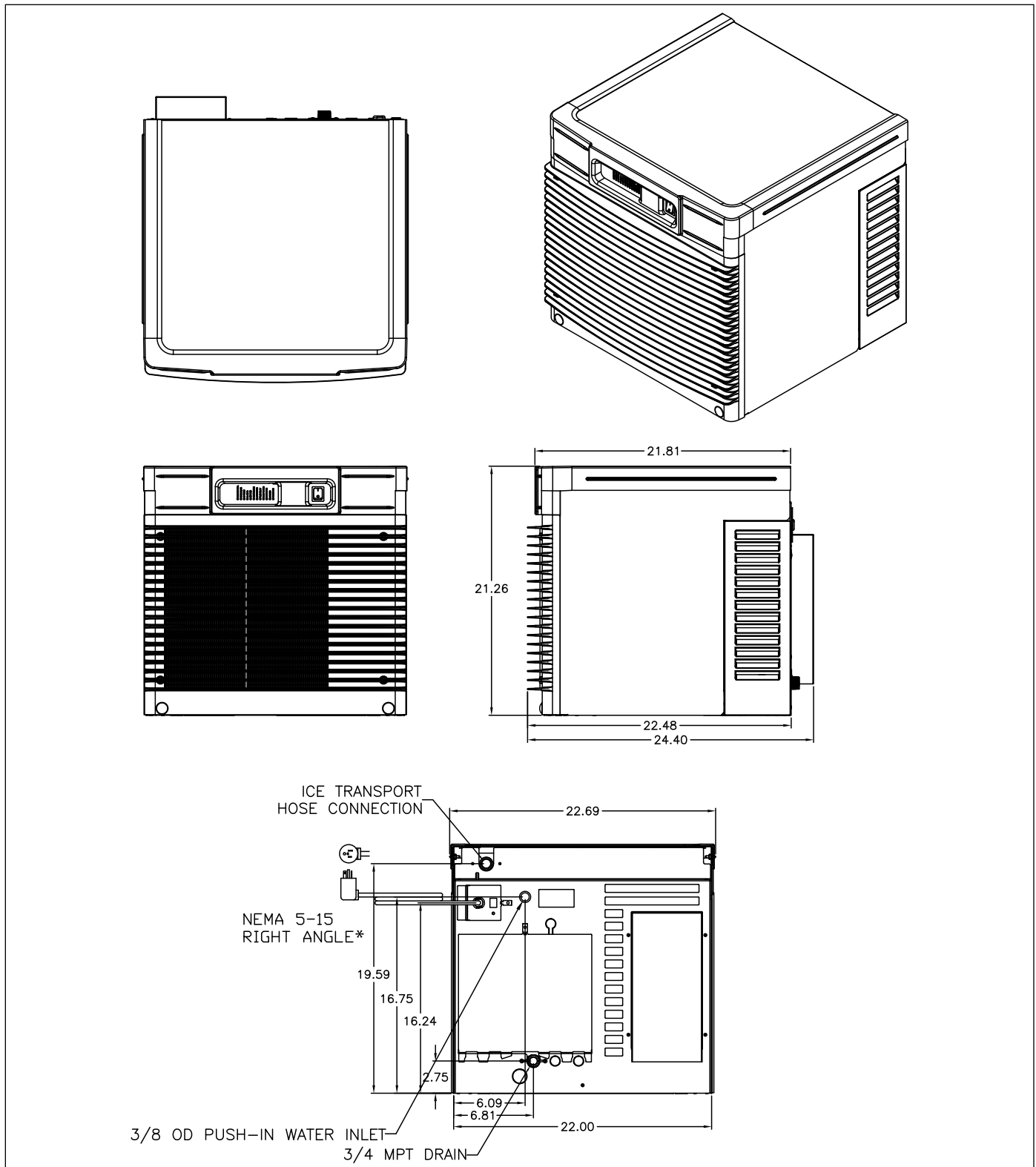

Operation

Cleaning/sanitizing and preventive maintenance (all models)

Note: Do not use bleach to sanitize or clean the icemaker.

Preventive maintenance

Periodic cleaning of Follett's icemaker system is required to ensure peak performance and delivery of clean, sanitary ice. The recommended cleaning procedures that follow should be performed at least as frequently as recommended, and more often if environmental conditions dictate.

Cleaning of the condenser can usually be performed by facility personnel. Cleaning of the icemaker system, in most cases, should be performed by your facility's maintenance staff or a Follett authorized service agent. Regardless of who performs the cleaning, it is the operator's responsibility to see that this cleaning is performed according to the schedule below. Service problems resulting from lack of preventive maintenance will not be covered under the Follett warranty.

Weekly exterior care

The exterior may be cleaned with a stainless cleaner such as 3M Stainless Steel Cleaner & Polish or equivalent.

Monthly condenser cleaning (air-cooled icemaker only)

1. Use a vacuum cleaner or stiff brush to carefully clean condenser coils of air-cooled icemakers to ensure optimal performance.
2. When reinstalling counter panels in front of remote icemakers, be sure that ventilation louvers line up with condenser air duct.

Semi-annual evaporator cleaning (every 6 months)

 WARNING
<ul style="list-style-type: none">• Wear rubber gloves and safety goggles (and/or face shield) when handling ice machine cleaner or sanitizer.

 CAUTION
<ul style="list-style-type: none">• Use only Follett approved SafeCLEAN Plus™ cleaning solution.• DO NOT USE BLEACH.• It is a violation of Federal law to use these solutions in a manner inconsistent with their labeling.• Read and understand all labels printed on packaging before use.

Note: Complete procedure for cleaning and sanitizing MUST be followed. Ice must be collected for 10 minutes before putting ice machine back into service.

1. Press the CLEAN button. The machine will drain. The auger will run for a short time and then stop. Wait for the LOW WATER light to come on.

Fig. 1

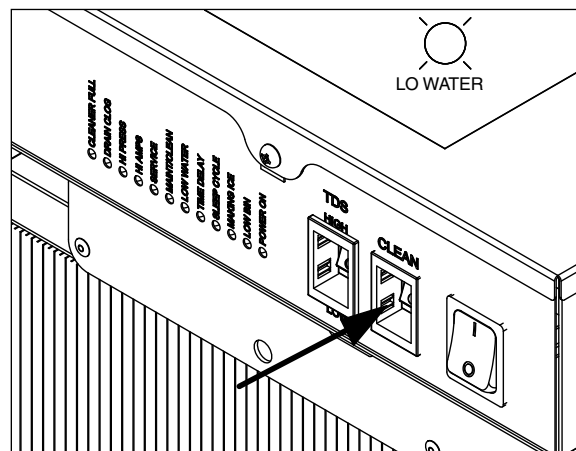

2. Follow the directions on the SafeCLEAN Plus packaging to mix 1 gal. (3.8 L) of Follett SafeCLEAN Plus solution. Use 100 F (38 C) water.
3. Using a 1 quart (1L) container, slowly fill cleaning cup until CLEANER FULL light comes on. Do not overfill.
4. Soak one SaniSponge™ in remaining sanitizing and cleaning solution and retain for Step 9.

Note: Do not use bleach to sanitize or clean the icemaker.

Fig. 2

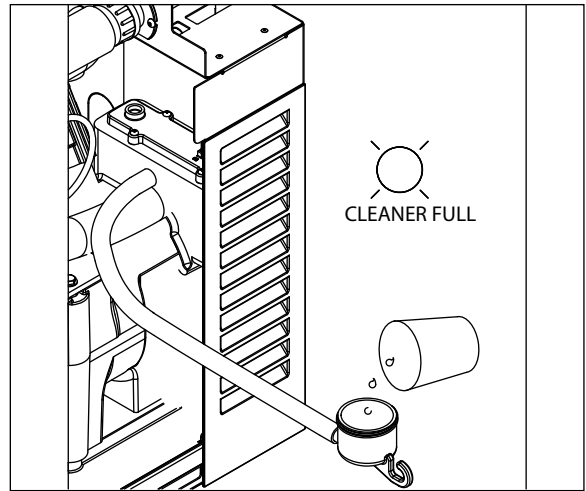

5. Replace cover on cleaner cup. Machine will clean, then flush 3 times in approximately 15 minutes. Wait until machine restarts.

Fig. 3

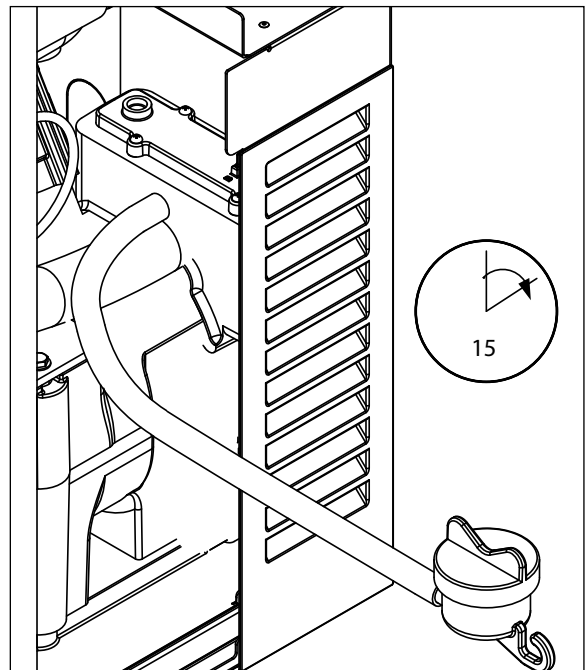

6. To clean/sanitize ice transport tube – Press power switch OFF

Fig. 4

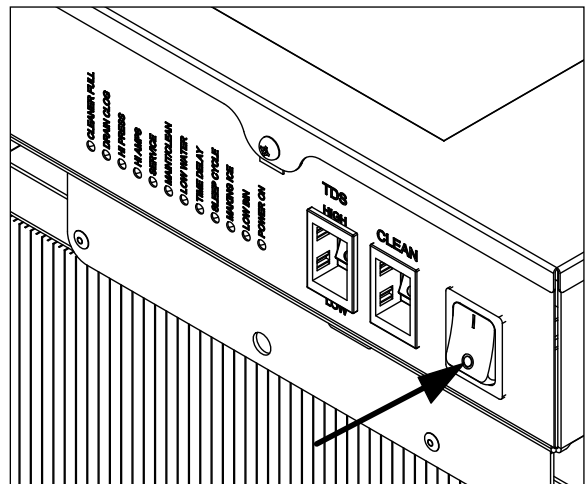

7. Disconnect coupling as shown.

Fig. 5

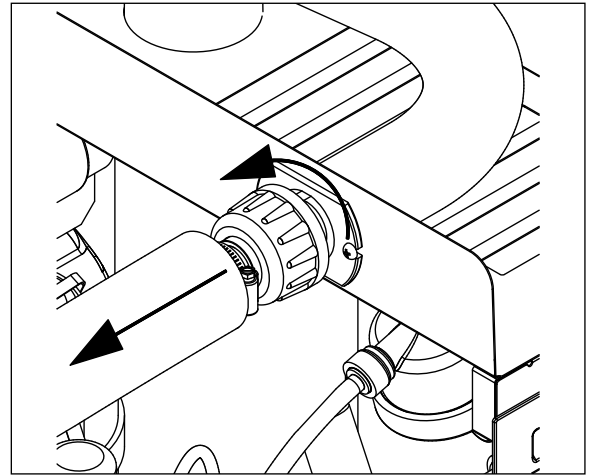

8. Using disposable food service grade gloves, insert dry SaniSponge.
9. Insert SaniSponge soaked in SafeClean Plus (from Step 4).
10. Push both SaniSponges down ice transport tube with supplied pusher tube.

Fig. 6

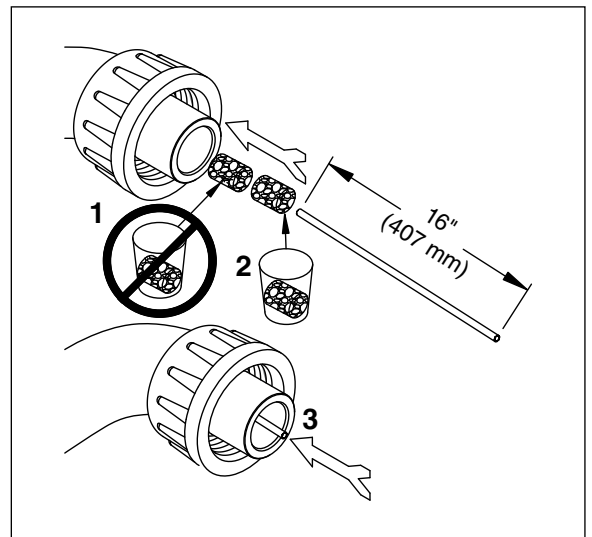

11. Remove and discard 16 inch (407 mm) pusher tube.

Fig. 7

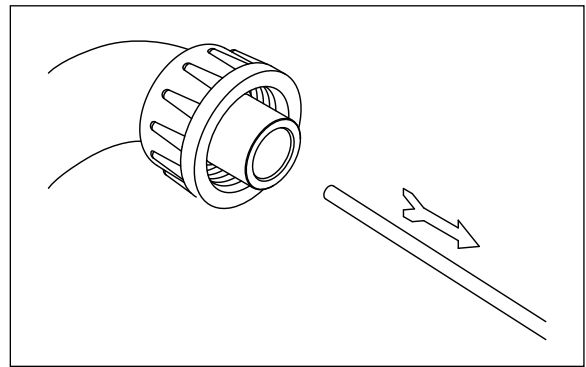

12. Reconnect coupling. Press power switch ON. Ice pushes SaniSponges through ice transport tube.

Fig. 8

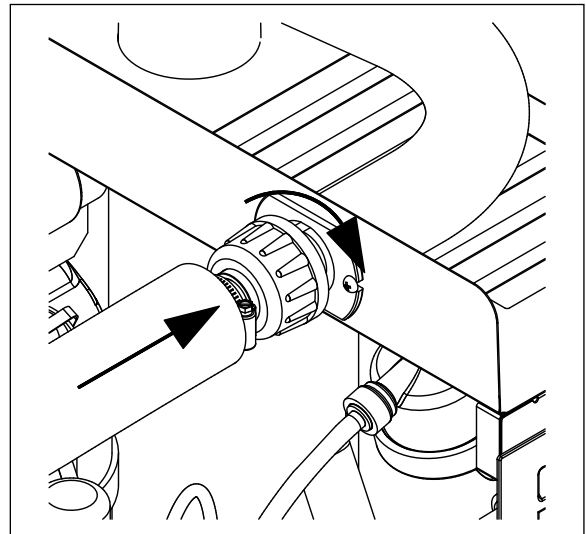

13. Place a sanitary (2 gal. or larger) container in bin or dispenser to collect SaniSponges and ice for 10 minutes.

14. Collect 5.5 lbs (3 kg) of ice from unit. Discard ice and SaniSponges.

Fig. 9

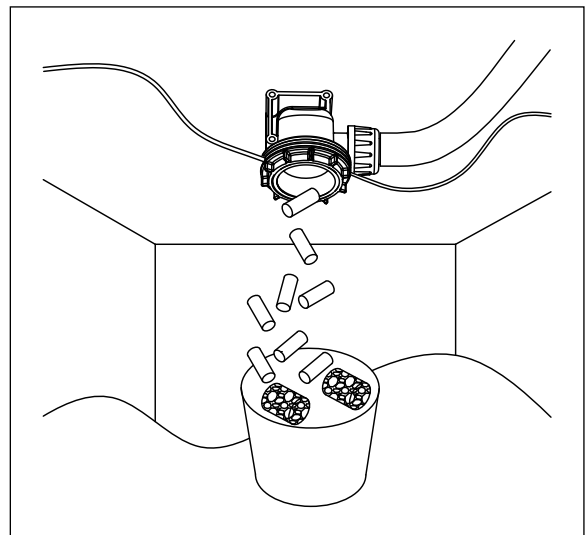

Service

Ice machine operation (all models)

Follett's ice machine consists of five distinct functional systems covered in detail as follows:

- Water system
- Electrical control system
- Mechanical assembly
- Refrigeration system
- Bin full

The Horizon ice machine overview

The Follett Horizon ice machine uses a horizontal, cylindrical evaporator to freeze water on its inner surface. The refrigeration cycle is continuous; there is no batch cycle. The evaporator is flooded with water and the level is controlled by sensors in a reservoir. A rotating auger continuously scrapes ice from the inner wall of the evaporator. The auger moves harvested ice through the evaporator into an ice extrusion canal. The ice is forced through a restrictive nozzle that squeezes out the water and creates the Chewblet. The continuous extrusion process pushes the Chewblets through a transport tube into a dispenser or bin.

A solid state PC board controls and monitors the functionality of the ice machine. In addition to sequencing electrical components, the board monitors various operational parameters. A full complement of indicator lights allows visual status of the machine's operation. Additionally, the PC board controls the self-flushing feature of the ice machine. The evaporator water is periodically drained and replenished to remove minerals and sediment.

A unique "bin full" detection system is incorporated in the Horizon ice machine. A switch located at the ice discharge port of the machine detects the position of the transport tube. When the bin fills up with ice, the transport tube moves out of the normal running position, and the switch turns the ice maker off. A domed housing at the end of the transport tube contains the ice extrusion loads during shut down.

Harvest system diagram

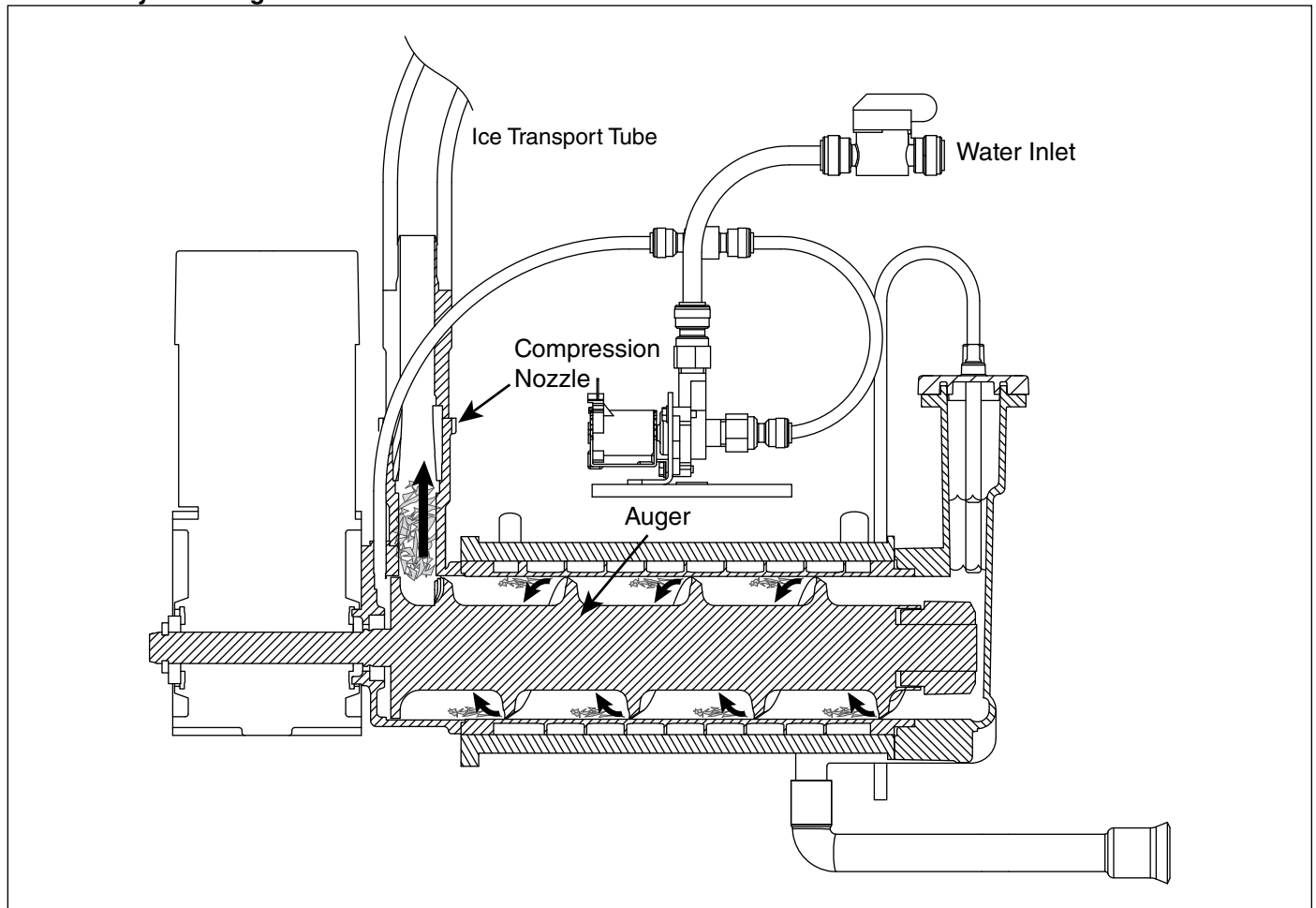

“Bin full” detection system

The Follett Horizon ice machine incorporates a unique “bin full” detection system that consists of the shuttle and actuator. The shuttle incorporates a flag and switch. Referencing the figure below, the normal running position of the flag is down, and the switch is closed. When the bin fills to the top and ice can no longer move through the tube, the machine will force the shuttle flag up, opening the switch and shutting the machine off. The shuttle actuator, located above the ice bin allows the ice to curl up within it when the bin is full. In this way, there are no loads generated that would tend to lift off the lid of the bin.

Shuttle flag and sensor

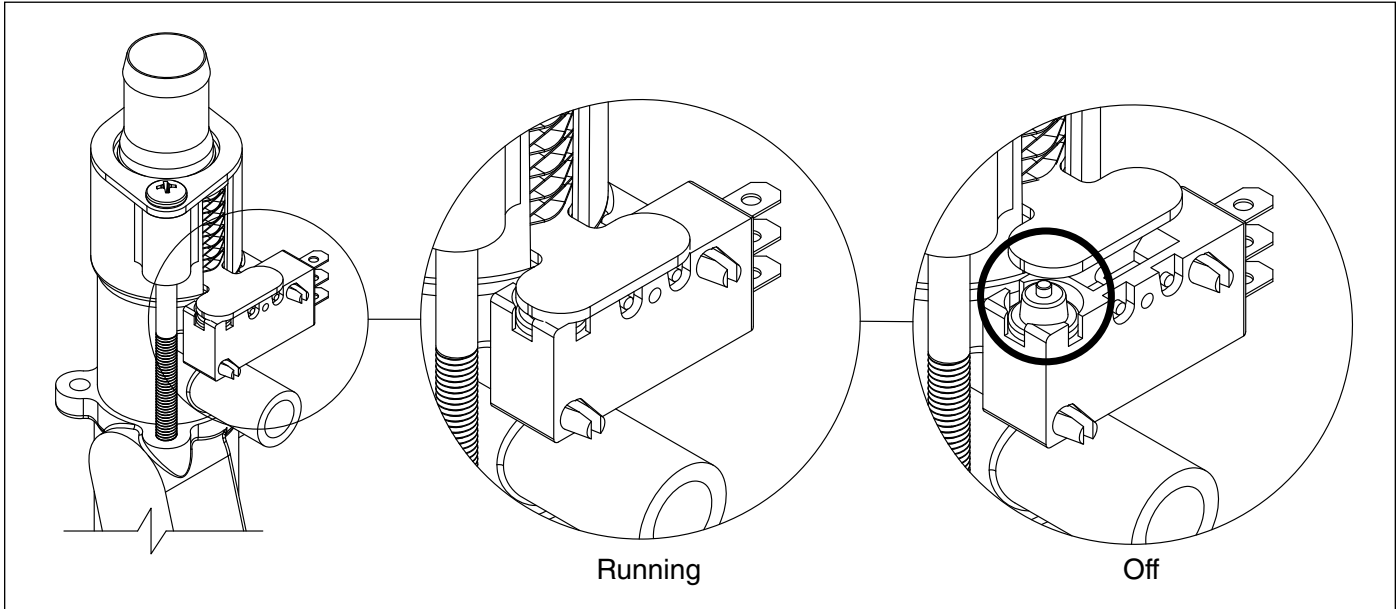

Shuttle actuator

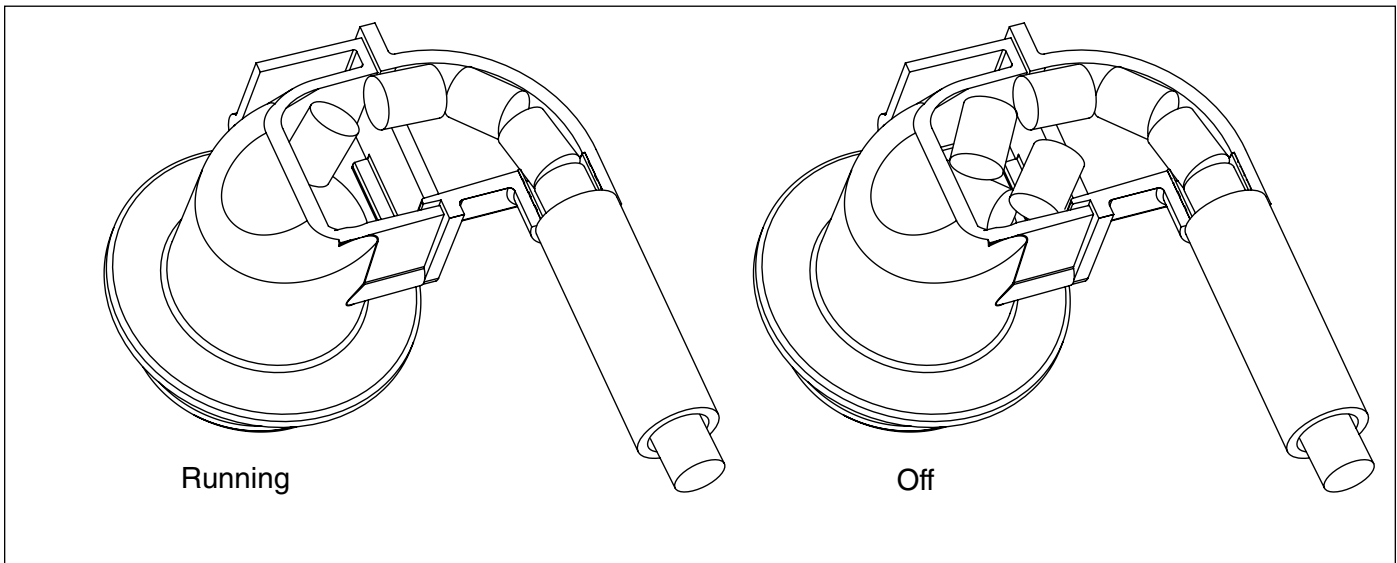

Water system

The water level in the evaporator is controlled by a feed solenoid and level detecting sensors. Referencing the diagram below, water sensing probes extend down into the reservoir at the end of the evaporator assembly. The system works via electrical conductivity as follows:

The probe labeled B is the common. When water is between any of the other probes and the common, the PC board will sense the activation. During normal operation, the water level rises and falls between the Normal High and Normal Low probes. As water is consumed to make ice, the level will fall until the Normal Low probe is exposed, triggering the water feed solenoid on. Water will fill until the Normal High sensor is activated.

Note: The potable water total dissolved solids (TDS) content must be greater than 10 ppm for the water control system to function properly. If using reverse osmosis water filtration system, ensure TDS level is greater than 10 ppm.

Water system diagram

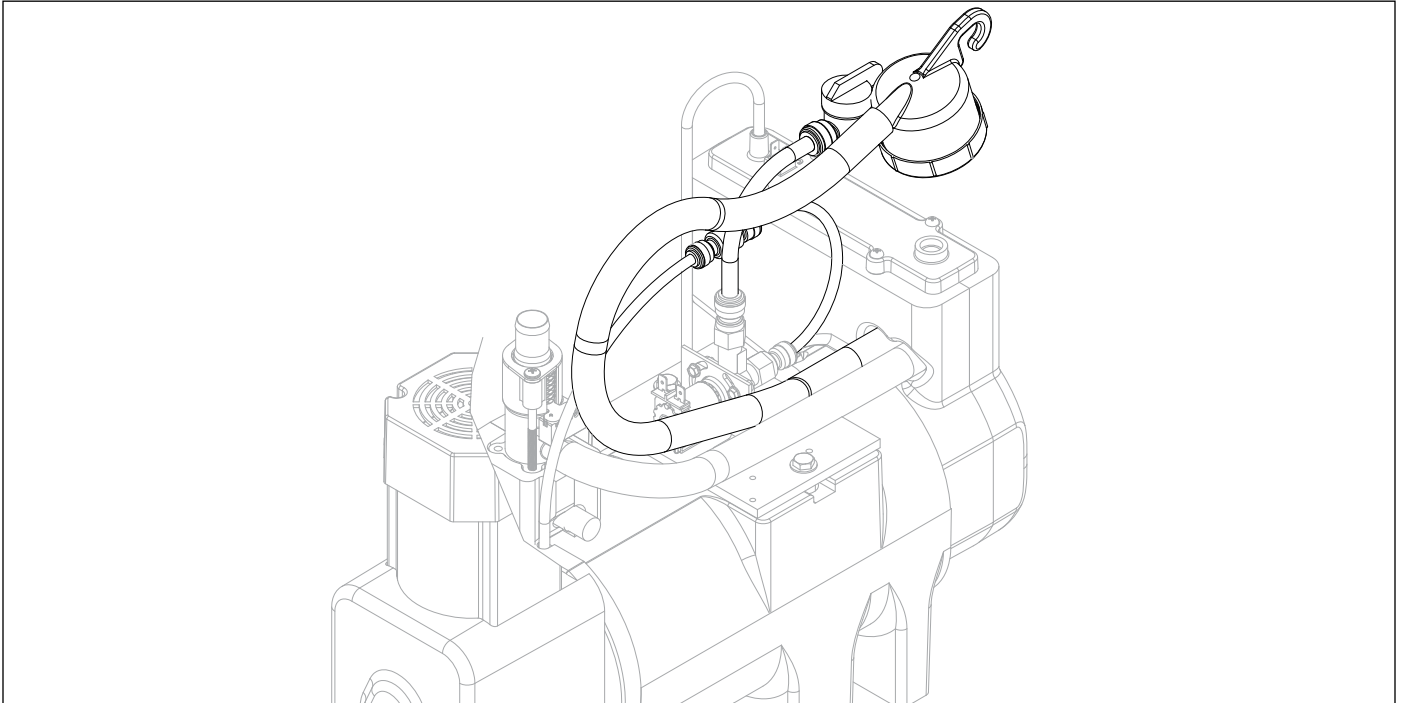

Water level diagram

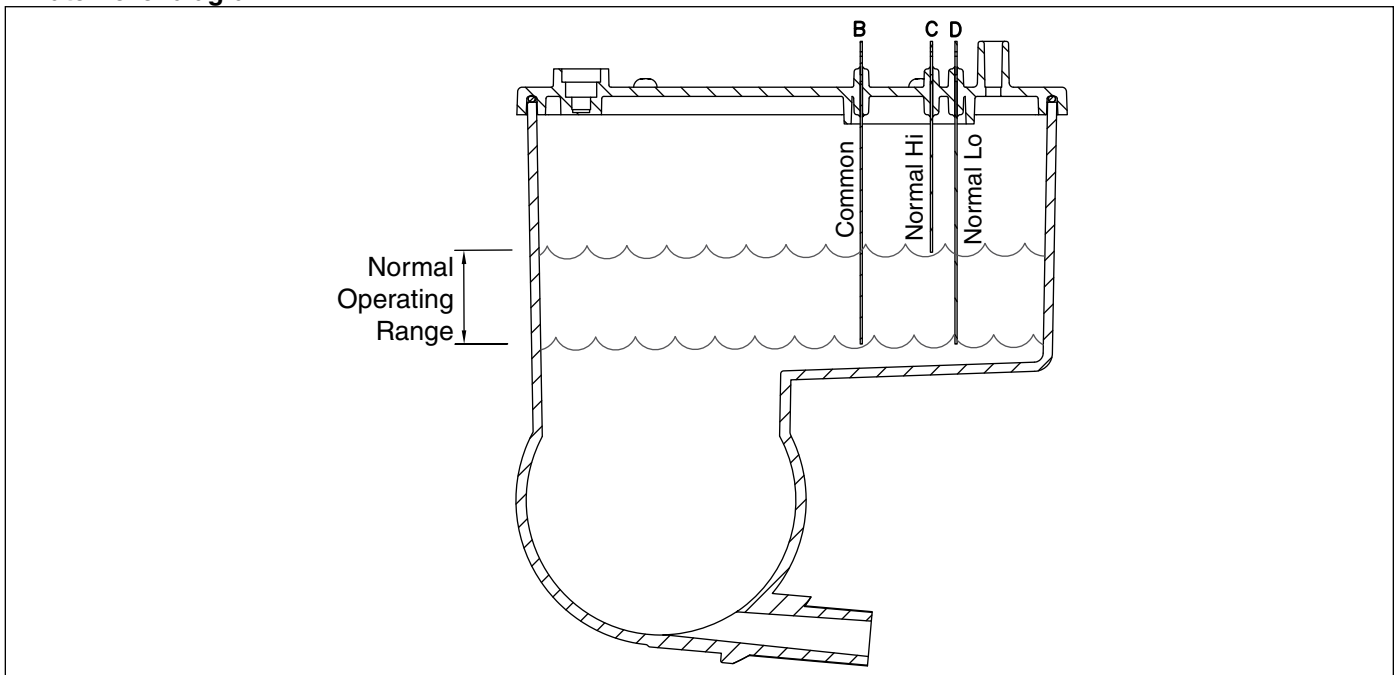

Electrical system



ATTENTION!

To prevent circuit breaker/Hi-amp overload, wait 5 minutes before restarting this unit. This allows the compressor to equalize and the evaporator to thaw.

Normal control board operation

The PC board indicator lights provide all the information necessary to determine the machine's status. Green indicator lights generally represent "go" or normal operation; Yellow indicators represent normal off conditions; Red indicators generally represent alarm conditions, some of which will lock the machine off.

A flashing green light labeled POWER indicates power to the machine. All other normal operation status indicators are covered as follows:

Ice machine disposition	Operating conditions
Legend: ● ON ○ OFF ◐ ON or OFF ◑ FLASHING	
1. Ice machine is making ice. CLEANER FULL ○ DRAIN CLOG ○ HI PRESS ○ HI AMPS ○ SERVICE ○ MAINT/CLEAN ○ LOW WATER ○ TIME DELAY ○ NOT USED ○ MAKING ICE ● LOW BIN ● POWER ON ◑	1. Normal running.
2. Ice machine is not making ice. CLEANER FULL ○ DRAIN CLOG ○ HI PRESS ○ HI AMPS ○ SERVICE ○ MAINT/CLEAN ○ LOW WATER ● TIME DELAY ○ NOT USED ○ MAKING ICE ○ LOW BIN ◐ POWER ON ◑	2. Normal time delay. When the bin fills with ice, the LOW BIN light goes out momentarily and the refrigeration and auger drive systems immediately shut down. (Note: The fan motor will continue to run for 10 minutes to cool condenser) The TIME DELAY light comes on, initiating the time delay period. When the time delay expires, the machine will restart provided that the LOW BIN light is on.

DIP Switch Settings

	OFF	ON	
MUST BE OFF	<input checked="" type="checkbox"/>	<input type="checkbox"/>	1
MUST BE OFF	<input checked="" type="checkbox"/>	<input type="checkbox"/>	2
MUST BE OFF	<input checked="" type="checkbox"/>	<input type="checkbox"/>	3
MUST BE OFF	<input checked="" type="checkbox"/>	<input type="checkbox"/>	4
MUST BE OFF	<input checked="" type="checkbox"/>	<input type="checkbox"/>	5
	<input type="checkbox"/>	<input checked="" type="checkbox"/>	6 MUST BE ON
Flush disabled	<input type="checkbox"/>	<input checked="" type="checkbox"/>	7 Flush enabled
Maintenance timer ON	<input type="checkbox"/>	<input checked="" type="checkbox"/>	8 Maintenance timer OFF

Error faults:

The Horizon PC board monitors various operating parameters including high pressure, auger gearmotor amperage limits, clogged drain, and low water alarm conditions. There are three types of errors namely "soft" (time delay) "hard" (reset), and "run".

- Soft errors will automatically reset after the 1 hour time delay or can be reset by cycling power.
- Hard errors must be reset on the control board.
- Run errors will give an indication of a problem, but will allow continuous normal operation.

Soft errors:

HI AMPS: The PC board monitors the amperage of the auger motor. Should the gear motor experience current draw above the allowable limit, the machine will shut down and the TIME DELAY and HI AMP will be illuminated. After the time delay the machine will restart and the TIME DELAY and HI AMP will clear.

LO WATER: During operation, the water level cycles between the normal low and normal high sensors. Should the water be shut off to a running machine, a soft error will occur. The error sequence is as follows: During operation, the water level falls to the normal low sensor, and when it does the water feed solenoid is energized. If water is not detected at the normal low sensor within 10 seconds, a soft error will occur. The machine will shut down on a low water/time delay error. Should water return, it will fill to the normal low sensor and the machine will resume operation once the 1 hour time delay expires.

Water feed error: While in making ice mode, if the water level does not fall below the low probes for 9 minutes, the machine will enter a 1-hour time delay soft error with the LOW WATER light flashing. After the time delay expires, the machine will try to make ice.

HI PRESSURE: Should the refrigeration pressure rise above 425 psi, the machine will shut down and the TIME DELAY and HIGH PRESSURE will be illuminated. After the time delay, and if the pressure has fallen back below the reset point of 295 psi, the machine will restart and the TIME DELAY and HIGH PRESSURE will clear.

Hard error:

DRAIN CLOG: The drain clog sensor, located in the chassis will detect the presence of water just below the top edge of the chassis. After the sensors are dried off, the machine must be reset on the control board to resume operation.

Run errors:

DRAIN CLOG: When the machine shuts down on a full bin and there has been 30 minutes of cumulative compressor run time, the machine will purge before starting. During this purge, if water does not get below the low probe in the reservoir within 20 seconds, the Drain Clog LED will light. The machine will continue to run but this is an indication of a poorly draining machine and must be addressed.

Relay output indication:

Each relay on the board has an indicator light associated with its output. For example, when the relay for the water feed solenoid is energized, the adjacent indicator light glows green.

Evaporator flushing sequence:

During operation, the purge solenoid will open in order to drain water. There are two drain settings to choose from: High TDS or Low TDS. (There is a rocker switch behind the front cover of the machine.) The intent is to drain the Total Dissolved Solids from the machine while it makes ice.

While ice is being made, the TDS of the water in the evaporator increases in TDS concentration. Without periodic draining, the TDS levels will climb to very detrimental levels, levels that will cause scale to form and cause poor machine operation. The Low TDS setting will allow the machine to operate for one hour before going through the flushing sequence; the High TDS setting will allow the machine to run for 11 minutes before going through the flushing sequence.

The flushing sequence toggles the purge and fill solenoids three times. That is, the purge solenoid will energize until the water level drops below the low probe. The fill solenoid then energizes until water reaches the high probe, and so on for 3 cycles.

Typically, High TDS might be considered levels above 200 PPM, but local experience and varying water chemistry may compel a High TDS setting for best performance in even lower TDS levels.

Off cycle: At the completion of off-cycle time delay, the machine checks for a cumulative 30 minutes of ice making time since the last **off-cycle** flush. If the cumulative ice making time exceeds 30 minutes, the machine will open the drain valve for 60 seconds to drain the evaporator in its entirety. It will then refill with water and begin making ice. If the ice making time is less than 30 minutes, the machine will start and begin making ice without draining the evaporator.

Wiring diagram

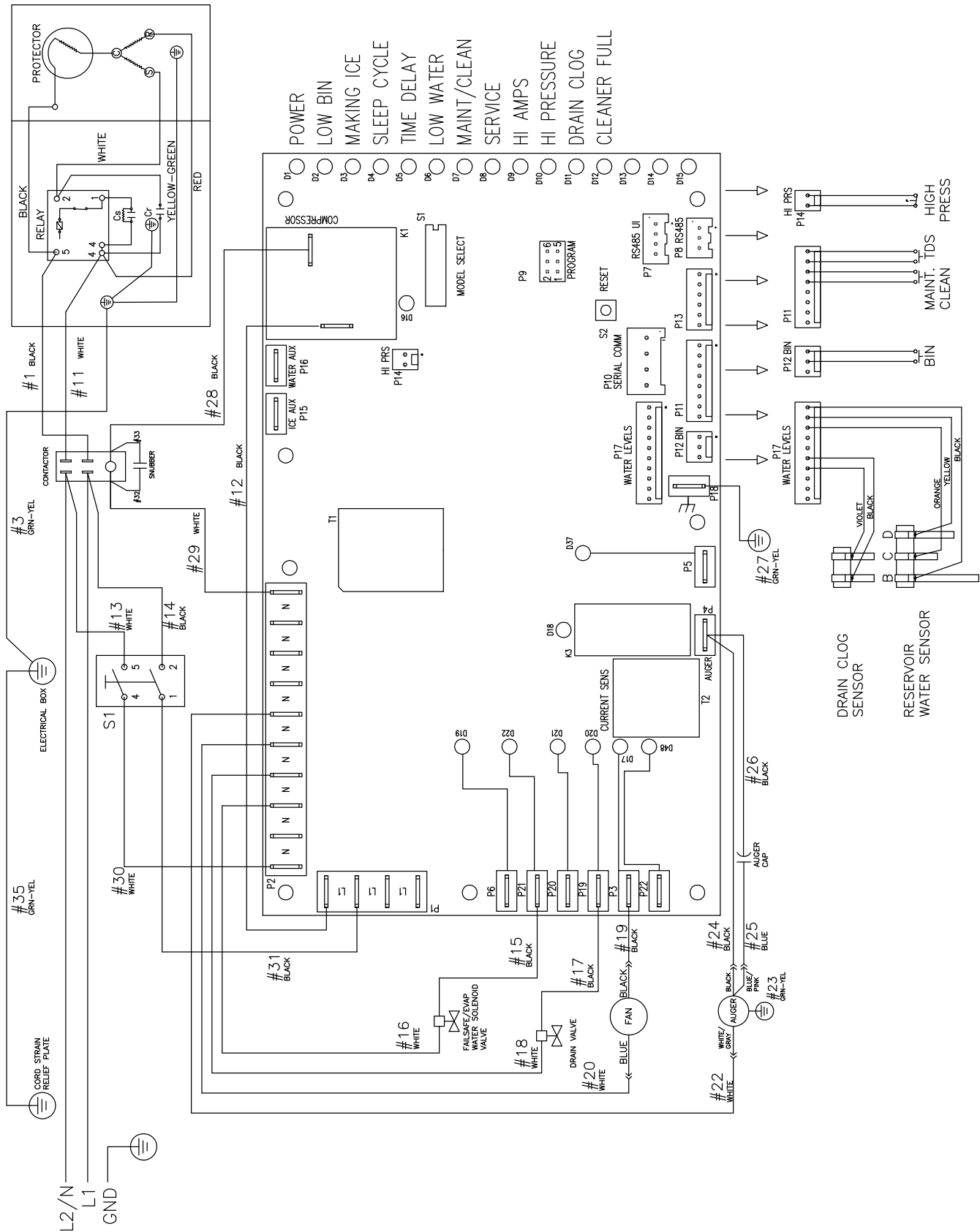

Compressor data

	710
Compressor current draw at 120 V VAC, 90 F/32.2 C	7.8A
Locked rotor amps @ 120 V	93.0A
Compressor start winding 120 V	2.23Ω
Compressor run winding 120 V	0.32Ω

Gearmotor data

Gearmotor current 1.2A @ 120 V

Gearmotor torque-out (high amp) trip point: 1.8A @ 120 V

Resistance of windings

115 vac gearmotor (Brother):

Gray to black: 15.5Ω

Blue to gray: 15.5Ω

Blue to black: 31Ω

Fan motor data

Fan motor current 0.2A @ 120 V

Fan motor resistance 100Ω

Mechanical System

Evaporator disassembly

1. Press CLEAN button to purge evaporator. Turn power OFF when LO WATER lights.
2. Unscrew and disconnect transport tube from louvered docking assembly.

Fig. 10

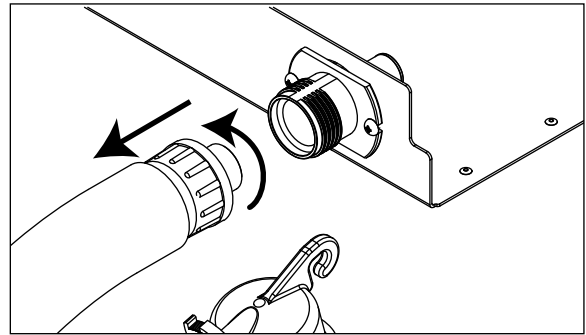

3. Remove gear motor insulation.

Fig. 11

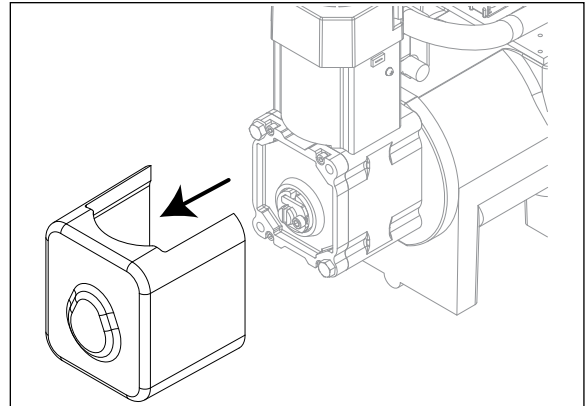

4. Disconnect gear motor wires and ground.

Fig. 12

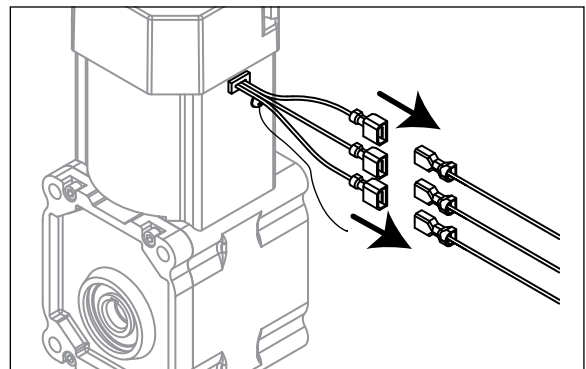

5. Remove screws (with 3/16" allen wrench) and auger retaining fork:

Fig. 13

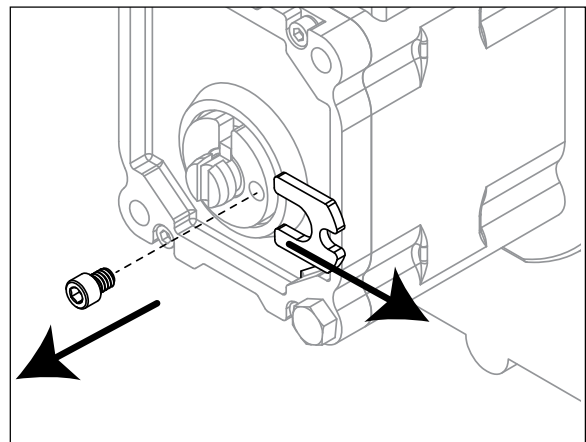

6. Remove spacer:

Fig. 14

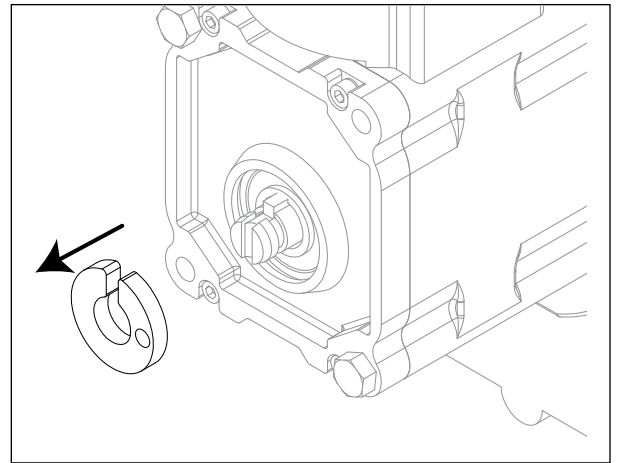

7. Remove gear motor bolts (1/2" wrench).

8. Remove gear motor and wipe auger shaft clean.

Fig. 15

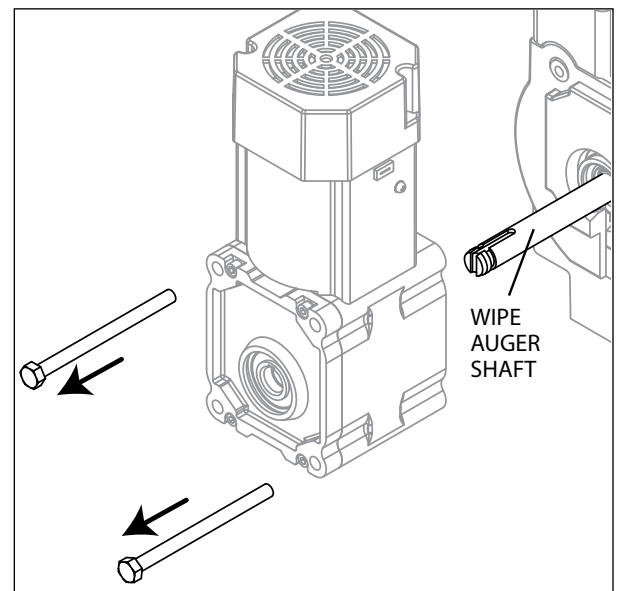

9. Remove main housing insulation and shuttle insulation.

Fig. 16

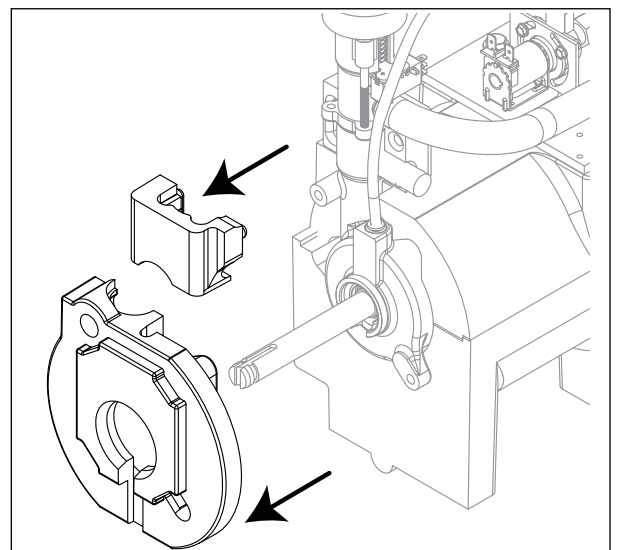

10. Remove front feed water tube from push-in fitting, shuttle drain tube, and shuttle switch.

Fig. 17

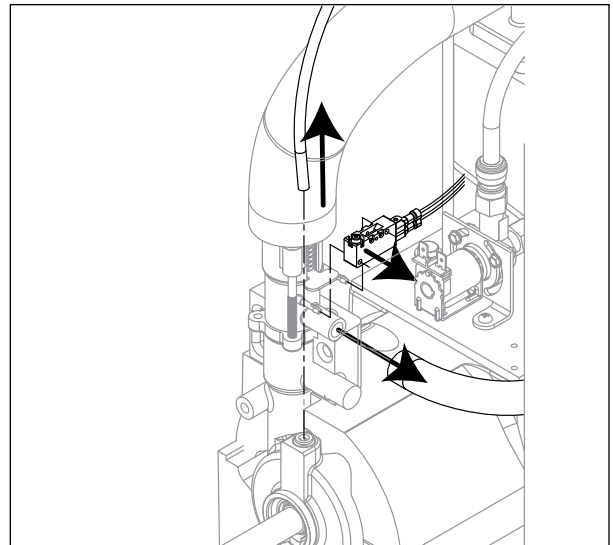

11. Remove 3 screws (with 3/16" allen wrench) then remove auger and main housing together.

Note: Auger is sharp - wear protective gloves.

Fig. 18

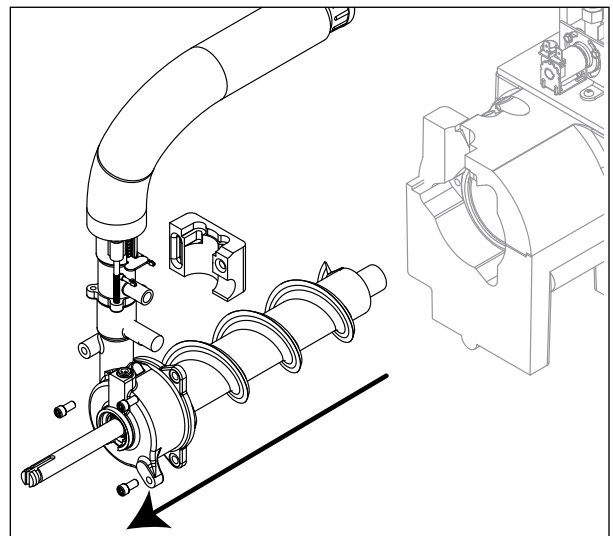

12. Rotate auger to align opening in auger flange with stream divider.
13. Pull out auger.

Fig. 19

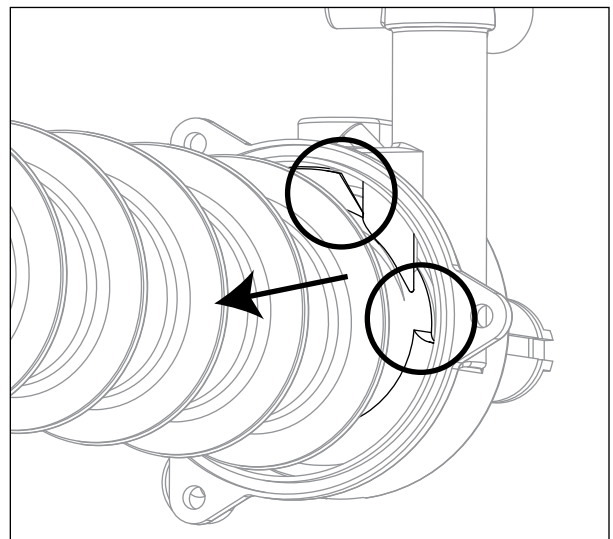

14. OPTIONAL: Remove and discard the ceramic mating ring and shaft seal as necessary.

Fig. 20

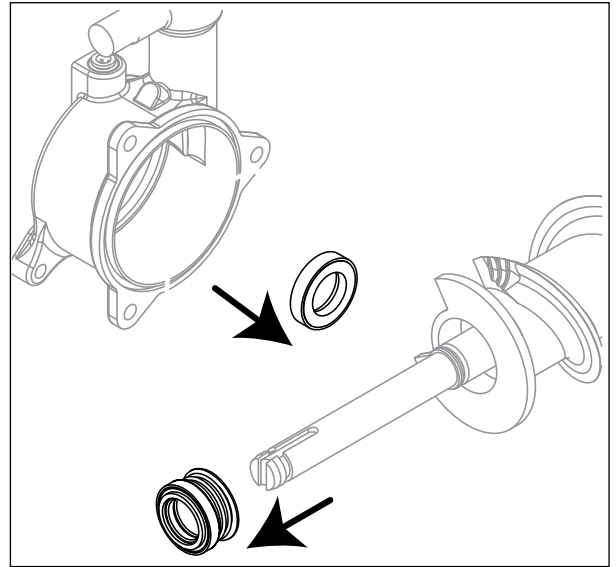

Evaporator reassembly

15. If removed prior, install ceramic mating ring and shaft seal.

Caution: Do not touch the sealed surface of either part. Oil from bare skin will cause premature seal failure.

16. Use liquid hand soap on the rubber part of the ceramic seal when installing in main housing. Use supplied cardboard disc to press into recess.
17. Apply liquid hand soap to raised area of auger shaft and interior rubber portion of shaft seal before installing seal.
18. Clean O ring groove. Lubricate O ring with petrol-gel and reinstall.

Fig. 21

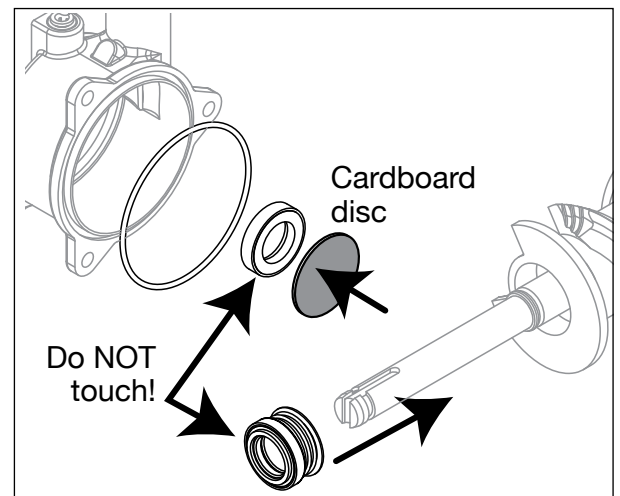

19. Carefully install auger.
20. Rotate auger to position shown to clear main housing stream divider.

Fig. 22

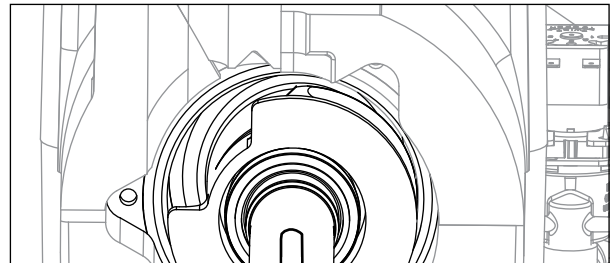

21. Install rear shuttle insulation (**Fig. 23.1**) and slide main housing (**Fig. 23.2**) onto auger.
22. Secure with three screws.

Fig. 23

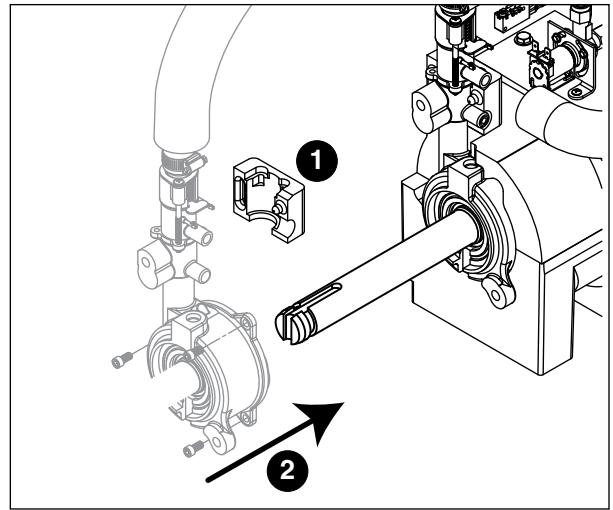

23. Install shuttle switch.
 - Align holes with pins (**Fig. 24.1**) and depress switch button (**Fig. 24.2**) to clear shuttle tab.

Fig. 24

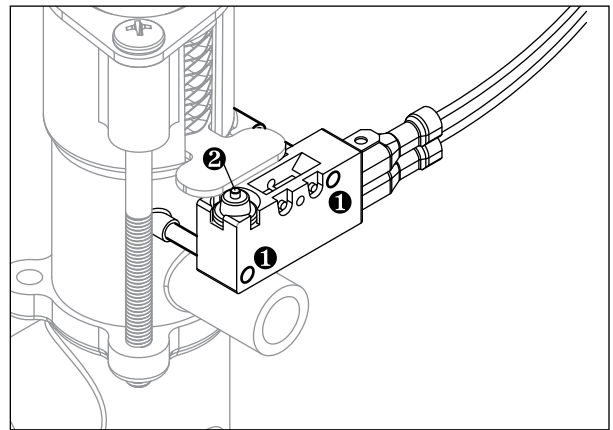

24. Install shuttle drain tube and front feed water tube (**Fig. 25**).
Note: Ensure water feed tube is inserted 5/8".

Fig. 25

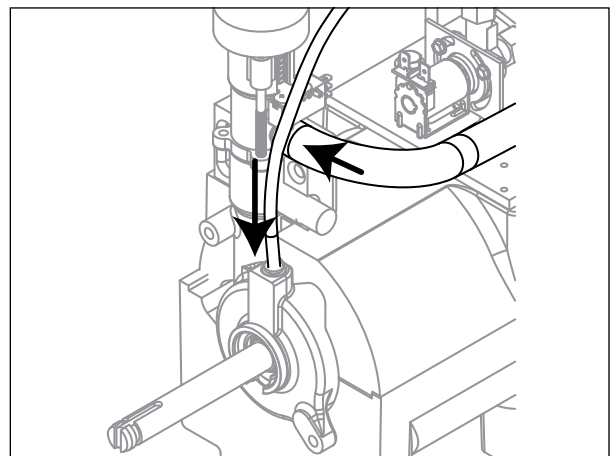

25. Install main housing insulation and shuttle insulation:

Fig. 26

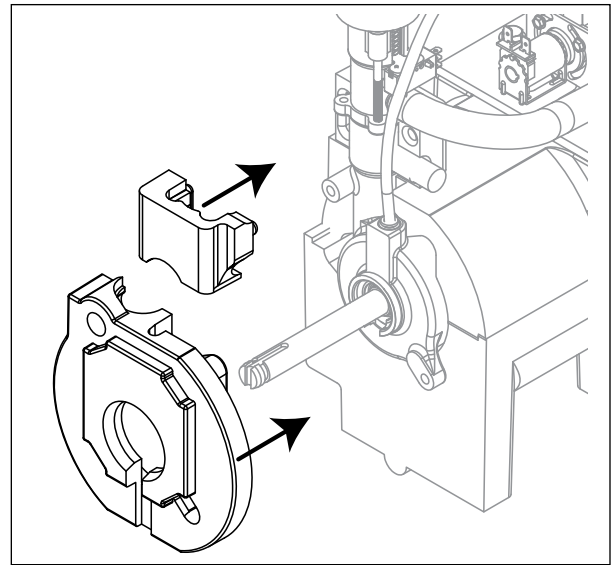

- 26. Apply a coat of petrol-gel to auger shaft.
- 27. Slide gear motor onto auger and install gear motor bolts (1/2" wrench).

Fig. 27

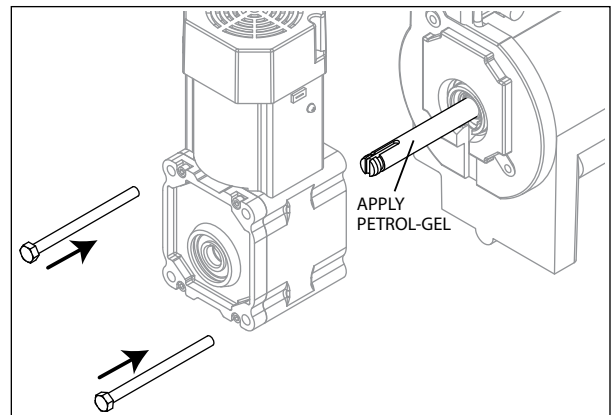

- 28. Use screwdriver to pry auger shaft forward, then orient auger shaft to align with motor shaft keyway (Fig. 28.1).
- 29. Install key fully into keyway (Fig. 28.2).

Fig. 28

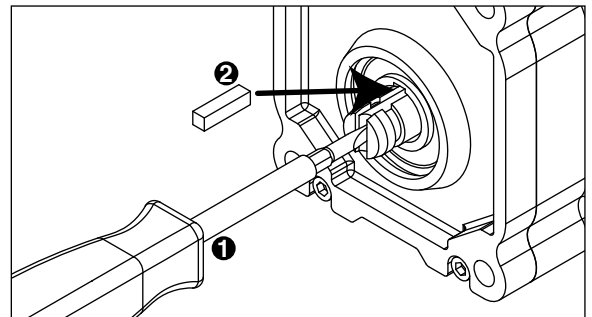

30. Install spacer, ensure that key is captured in slot.

Fig. 29

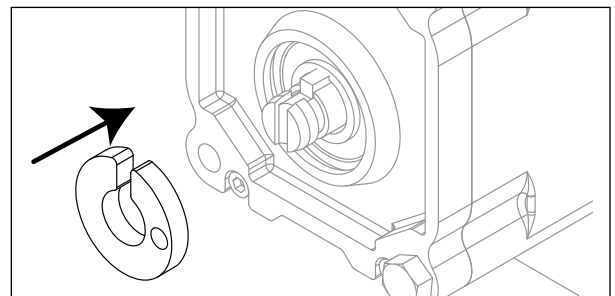

- 31. Insert screwdriver into groove of auger shaft and pry shaft outwards (**Fig. 30.1**).
- 32. Insert retainer into groove (**Fig. 30.2**), ensure that retainer is aligned with hole in spacer.

Fig. 30

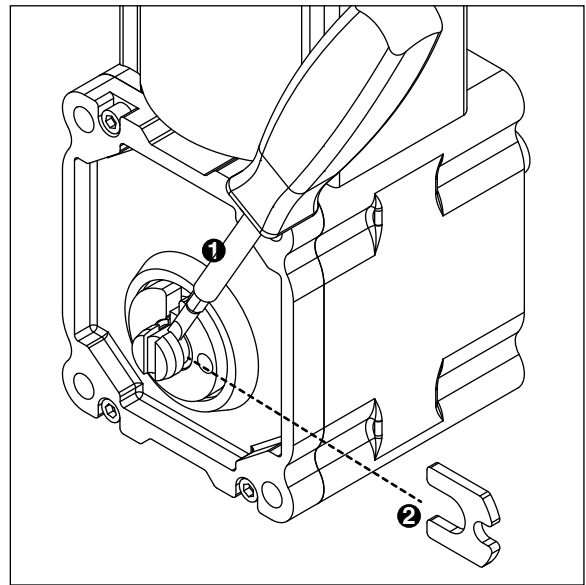

- 33. Install screw and tighten (**Fig. 31.1**).

Fig. 31

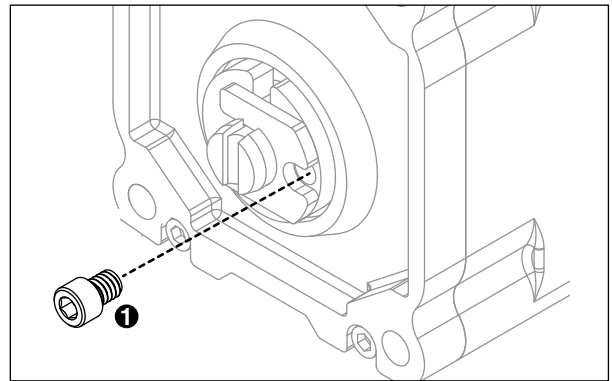

- 34. Connect gear motor wires and ground wire.

Fig. 32

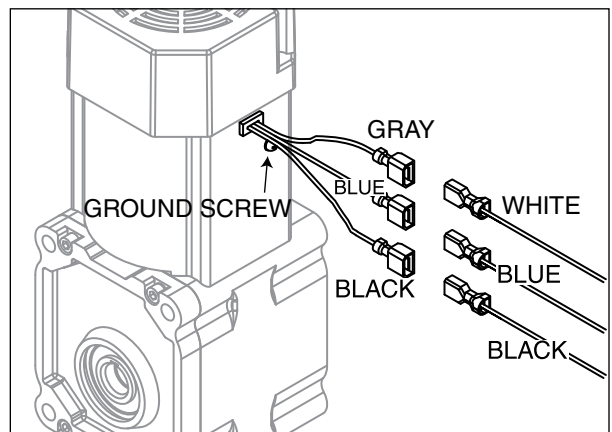

35. Install gear motor insulation.

Fig. 33

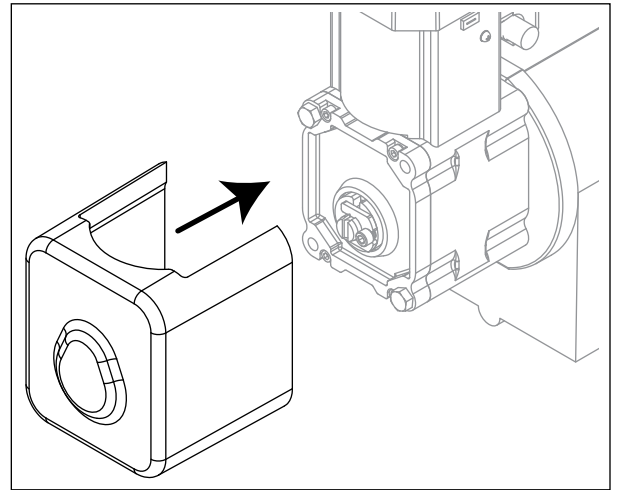

36. Connect transport tube to louvered docking assembly.

Fig. 34

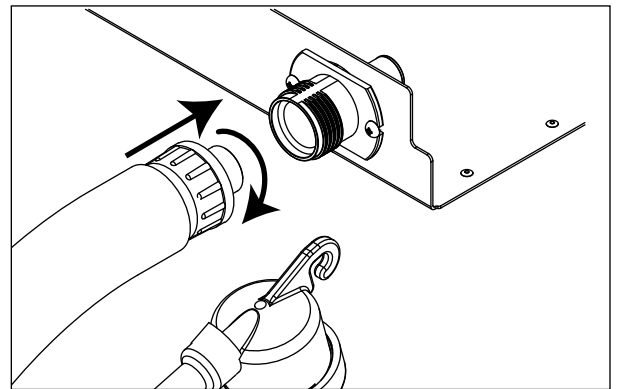

Reservoir/rear bushing disassembly Fig. 35

1. Press CLEAN button to purge evaporator. Turn power OFF when LO WATER lights.

Note: In many applications, removing the gearmotor, main housing, and auger will allow for the ice machine to be pulled out further for better access to rear components.

2. Slide ice machine forward to gain access.
3. Use Fig. 35 as disassembly guide.

Note: Use petrol-gel when installing/reinstalling o-rings.

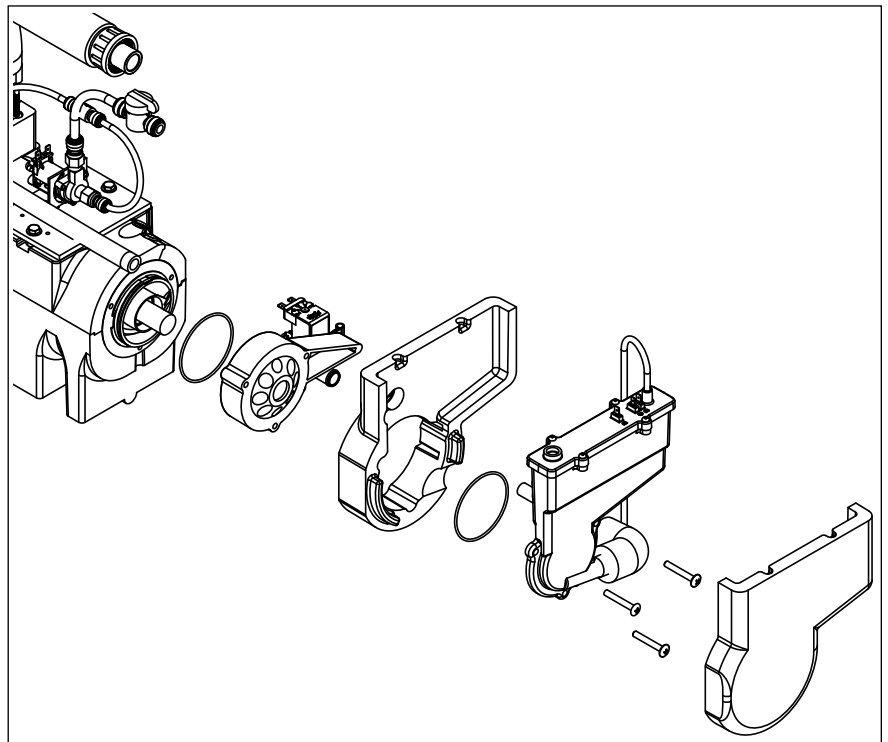

Refrigeration system

Refrigerant pressure data

Air-cooled condensers (air)	60 F/16 C	70 F/21 C	80 F/27 C	90 F/32 C	100 F/38 C
Pressure (psig) discharge/suction	190/32	225/34	258/36	292/39	325/41

Refrigeration charge

All service on refrigeration systems must be performed in accordance with all federal, state and local laws. It is the responsibility of the technician to ensure that these requirements are met. Recharging ice machine to other than factory specifications will void the warranty.

R404A ice machine charge specifications

Model	Charge	Refrigerant type
710A (air-cooled)	21 oz (595 g)	R404A

Refrigeration system diagram

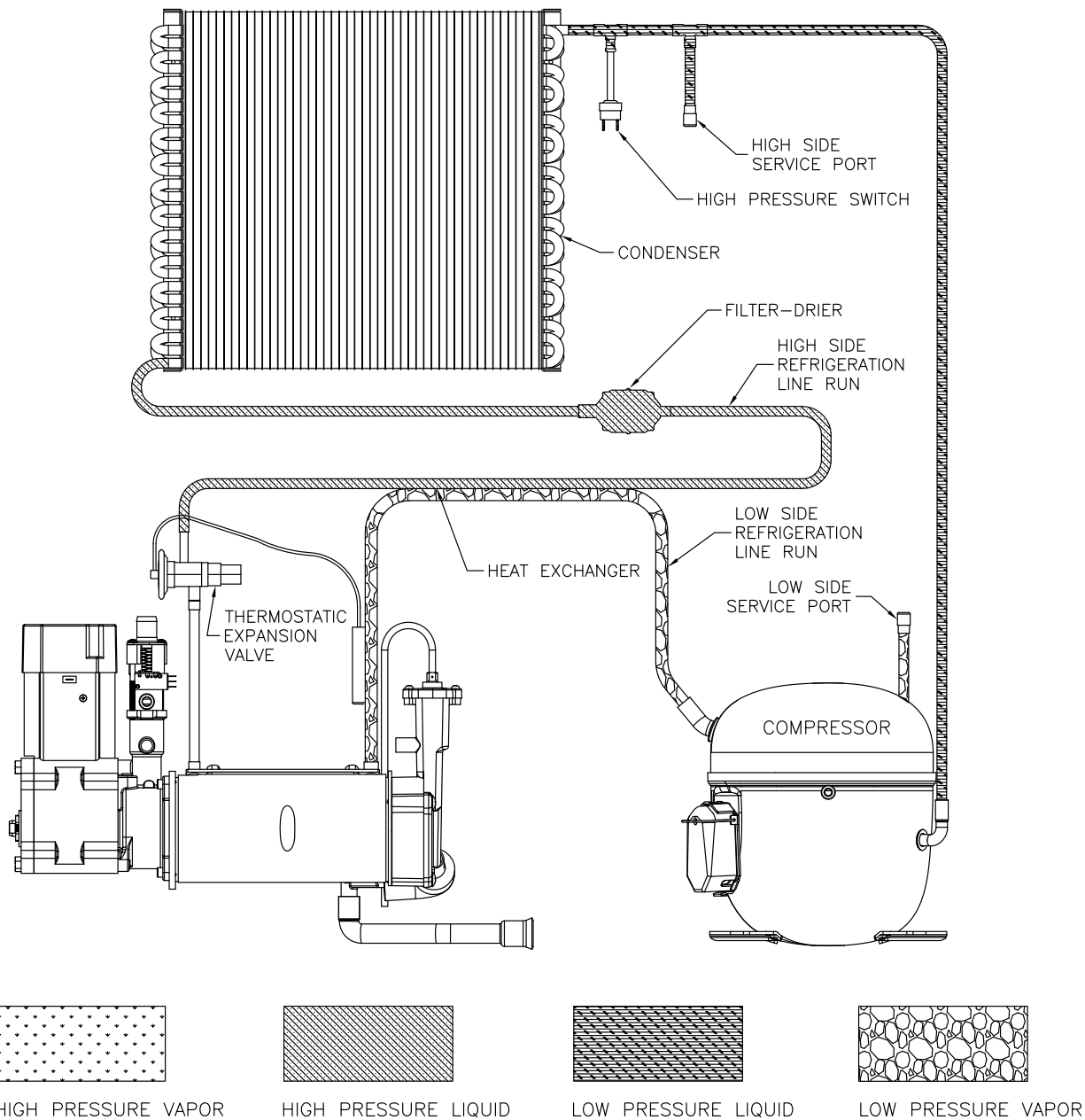

Evacuation

Evacuate the system to a level of 500 microns. When the 500 micron level is reached, close all valves. Allow the system to sit for approximately 20 minutes. During this period the system pressure should not rise. If the system pressure rises and stabilizes there is moisture in the system and further evacuation is needed. If the pressure continues to rise check the system for leaks.

Ambients	Minimum	Maximum
Air temperature ¹	50 F/10 C	100 F/37.8 C
Water temperature ²	45 F/7 C	90 F/32.2 C

¹Ambient air temperature is measured at the air-cooled condenser coil inlet.

²Ambient water temperature is measured at the water feed valve inlet.

Ice capacity test

Ice machine production capacity can only be determined by weighing ice produced in a specific time period.

1. Replace all panels on ice machine.
2. Run ice machine for at least 15 minutes.
3. Move TDS switch to LOW.
4. Press the reset button on the board.

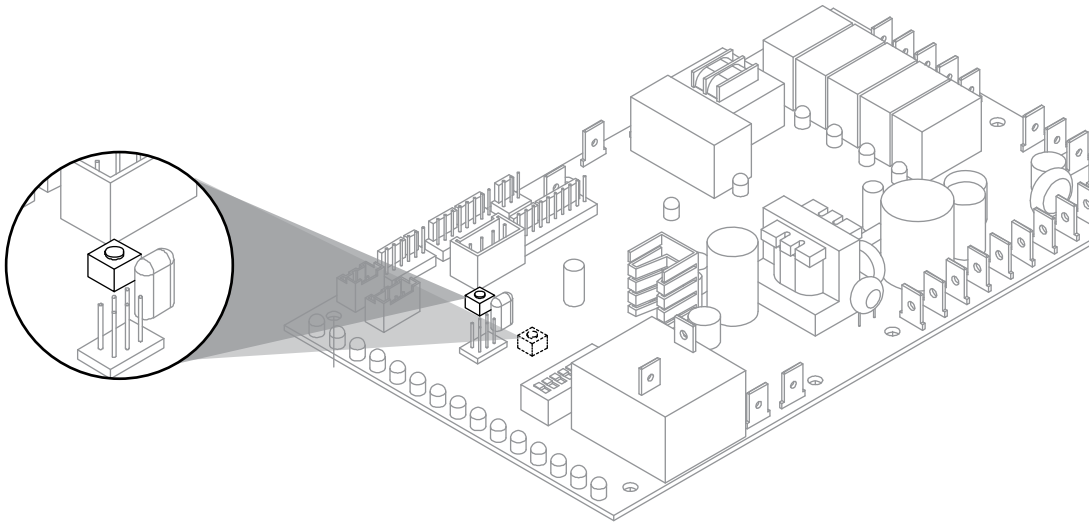

5. Weigh and record weight of container used to catch ice.
6. Catch ice for 15 minutes.
7. Weigh harvested ice and record total weight.
8. Subtract weight of container from total weight.
9. Convert fractions of pounds to decimal equivalents (ex. 6 lbs 8 oz = 6.5 lbs).
10. Calculate production using following formula:

$$\frac{1440 \text{ min.} \times \text{wt. of ice produced}}{\text{Total test time in minutes}} = \text{Production capacity/24 hr.}$$

11. Calculated amount per 24 hours should be checked against rated capacity for same ambient and water temperatures in Ice Production Tables.
12. Move TDS switch to the HI TDS position.

Troubleshooting

Please see “Service” section for a description of each function.

Ice machine disposition	Possible causes	Corrective action
Legend: ● ON ○ OFF ◐ ON or OFF ✖ FLASHING		
1. Ice machine is in running condition but not making ice. CLEANER FULL ○ DRAIN CLOG ○ HI PRESS ○ HI AMPS ○ SERVICE ○ MAINT/CLEAN ○ LOW WATER ○ TIME DELAY ○ NOT USED ○ MAKING ICE ● LOW BIN ○ POWER ON ✖	1. Defective compressor. 2. Defective start relay. 3. Defective start capacitor. 4. Defective run capacitor. 5. Defective main contactor. 6. No output from PC board.	1. Replace compressor. 2. Replace start relay. 3. Replace start capacitor. 4. Replace run capacitor. 5. Replace main contactor. 6. Replace PC board.
2. Machine in TIME DELAY without full bin. CLEANER FULL ○ DRAIN CLOG ○ HI PRESS ○ HI AMPS ○ SERVICE ○ MAINT/CLEAN ○ LOW WATER ○ TIME DELAY ◐ NOT USED ○ MAKING ICE ○ LOW BIN ○ POWER ON ✖	1. Ice jamming due to improperly installed transport tube causing a false shuttle. 2. Shuttle stuck in up position. 3. Damaged or improperly installed thermostat (open). 4. Transport tube backed-out of coupling.	1. Correct transport tube routing. 2. Repair or replace shuttle mechanism. 3. Replace or reposition thermostat. 4. Correct coupling installation.
3. Ice machine is not making ice. HI AMPS. CLEANER FULL ○ DRAIN CLOG ○ HI PRESS ○ HI AMPS ● SERVICE ○ MAINT/CLEAN ○ LOW WATER ○ TIME DELAY ○ NOT USED ○ MAKING ICE ○ LOW BIN ○ POWER ON ✖	1. Poor water quality causing ice to jam auger. 2. Drain not draining/slow to drain. 3. Damaged shuttle mechanism. 4. Intermittent drive output from PC board. Evaporator will freeze causing a HI AMPS error. 5. Gearmotor is unplugged.	1. Clean ice machine. Position TDS switch to High TDS setting. 2. Clear and/or correct drain. 3. Replace or repair shuttle mechanism. 4. Replace PC board. 5. Plug in gearmotor.
4. Ice machine is not making ice. HI PRESSURE. CLEANER FULL ○ DRAIN CLOG ○ HI PRESS ● HI AMPS ○ SERVICE ○ MAINT/CLEAN ○ LOW WATER ○ TIME DELAY ○ NOT USED ○ MAKING ICE ○ LOW BIN ○ POWER ON ✖	1. High ambient temperatures >100 F (38 C). 2. Poor ventilation or air recirculation. 3. Clogged condenser (air-cooled). 4. Fan not working properly. No air flow. <ul style="list-style-type: none"> • Blocked fan blades • No fan output from PC board • Faulty fan motor 	1. Air condition area to below 100 F (38 C). 2. Reposition ice machine or properly ventilate. Prevent ice machine exhaust from recirculating. 3. Clean condenser grille (air-cooled). 4. Correct air flow. <ul style="list-style-type: none"> • Remove any blockage from fan blades • Replace PC board • Replace fan motor
5. Ice machine is not making ice. Drain clog. CLEANER FULL ○ DRAIN CLOG ● HI PRESS ○ HI AMPS ○ SERVICE ○ MAINT/CLEAN ○ LOW WATER ○ TIME DELAY ○ NOT USED ○ MAKING ICE ○ LOW BIN ○ POWER ON ✖	1. Internal water leak touching chassis sensor.	1. Identify and repair leak. Clean/dry chassis and sensors and restart machine.

Ice machine disposition	Possible causes	Corrective action
Legend: ● ON ○ OFF ◐ ON or OFF ⊗ FLASHING		
6. Ice machine is making ice. Drain clog. CLEANER FULL ○ DRAIN CLOG ● HI PRESS ○ HI AMPS ○ SERVICE ○ MAINT/CLEAN ○ LOW WATER ○ TIME DELAY ◐ NOT USED ○ MAKING ICE ◐ LOW BIN ○ POWER ON ⊗	1. Improper flow in drain system.	1. Correct/clean drain system.
7. Ice machine is making ice. Excessive water in bin or coming into bin from transport tube. CLEANER FULL ○ DRAIN CLOG ○ HI PRESS ○ HI AMPS ○ SERVICE ○ MAINT/CLEAN ○ LOW WATER ○ TIME DELAY ○ NOT USED ○ MAKING ICE ● LOW BIN ● POWER ON ⊗	1. Failed water sensors. Processor assumes there is no water when there is water. 2. Blocked reservoir vent. 3. Defective water feed solenoid valve. Stuck in open position.	1. Clean or replace water probe assembly. Check wiring connections. 2. Clean or replace vent tubes. 3. Replace water feed solenoid valve.
8. Ice machine is not making ice. Lo water. CLEANER FULL ○ DRAIN CLOG ○ HI PRESS ○ HI AMPS ○ SERVICE ○ MAINT/CLEAN ○ LOW WATER ● TIME DELAY ◐ NOT USED ○ MAKING ICE ○ LOW BIN ○ POWER ON ⊗	1. Water supply is insufficient. 2. Low water pressure. 3. Defective water feed solenoid valve. Stuck in closed position. 4. No water feed output from PC board. 5. Plugged screen on inlet side of fill solenoid. 6. Plugged check valve.	1. Restore water supply and check water filters. If evaporator was completely empty the reset button may have to be pressed to restart the ice machine. 2. Ice machine will eventually start when water reaches normal lo level. 3. Replace water feed solenoid valve. 4. Replace PC board. 5. Remove and clean screen. 6. Remove and clean.
9. Blinking Low Water, power, time delay. CLEANER FULL ○ DRAIN CLOG ○ HI PRESS ○ HI AMPS ○ SERVICE ○ MAINT/CLEAN ○ LOW WATER ⊗ TIME DELAY ● NOT USED ○ MAKING ICE ○ LOW BIN ○ POWER ON ⊗	Machine did not see water consumption while trying to make ice. 1. Lack of refrigeration/low refrigerant charge/leak. 2. Debris shorting reservoir probes.	1. Verify refrigerant pressures, compressor running, sight glass clear. 2. Clean probes and reservoir of debris.



ATTENTION!

To prevent circuit breaker overload, wait 5 minutes before restarting this unit. This allows the compressor to equalize and the evaporator to thaw.

Replacement parts

Evaporator assembly

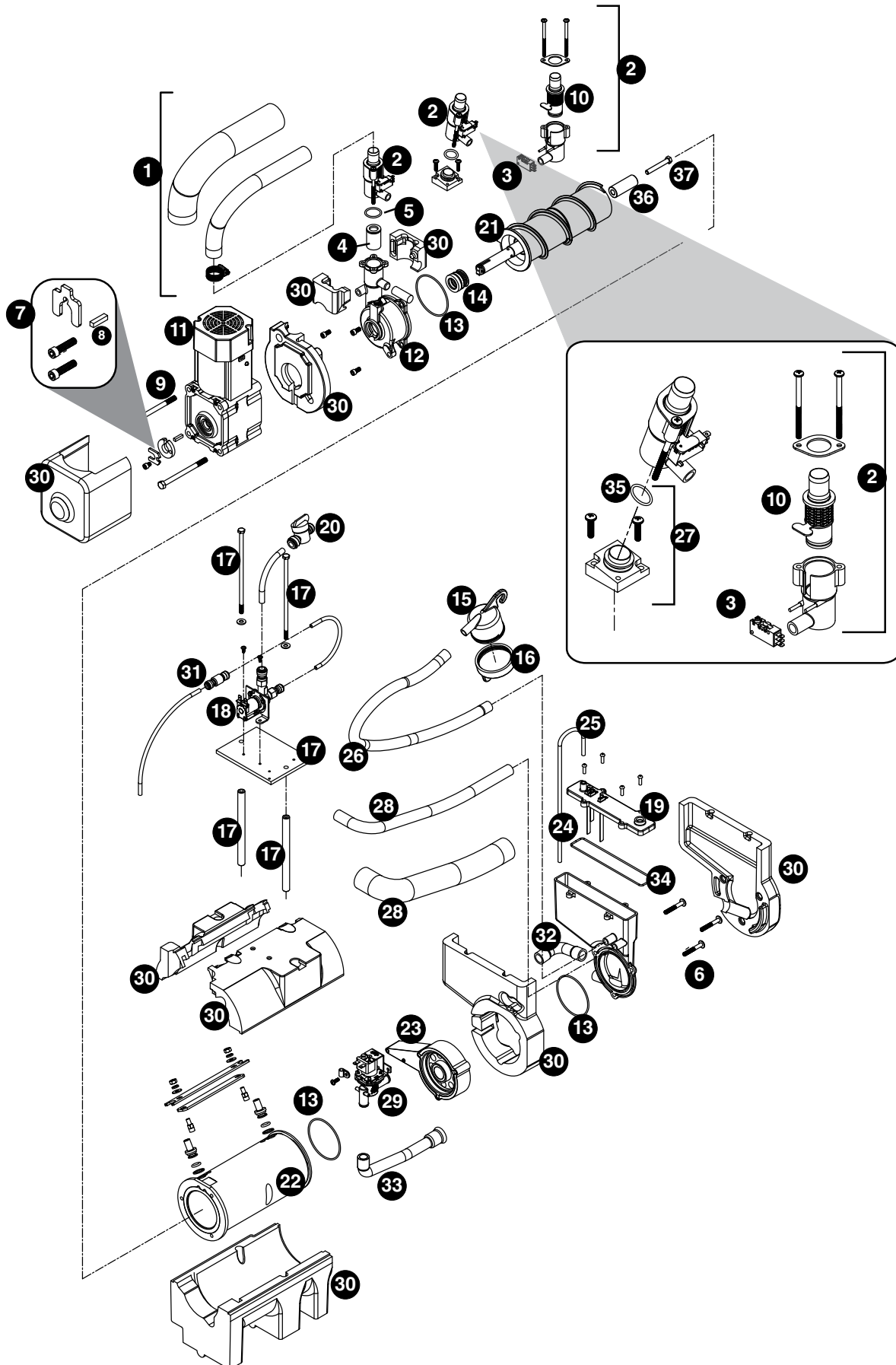

Reference #	Description	Part #
1	Tube, ice transport, insulated	01118181
2	Shuttle assembly	01118132
3	Switch, shuttle	01006261
4	Compression nozzle	01222744
5	O-ring, shuttle	01164920
6	Screw, reservoir (10 pack)	01333830
7	Auger hardware (includes screws, 3/4 inch key, retainer) S/N below L52860	01118611
7	Auger hardware (includes screws, 1.5 inch key, retainer) S/N above L52860	01402890
8	Key (2)	01348101
9	Bolt, gearmotor mounting (2) (self-contained units), includes washers	01118629
10	Cartridge assembly, shuttle spring	01118033
11	Gearmotor, (includes capacitor)	01222751
Not shown	Capacitor, gear motor	01543404
12	Main housing, self-contained	01222736
13	O ring	01248368
14	Seal, auger shaft	01333806
15	Cup, cleaner	01164995
16	Cap, cleaner	01118637
Not shown	Tubing, water, 3/8" OD	502719
Not shown	Tubing, water, 1/4" OD	502079
17	Retainer kit, evaporator	01223023
18	Solenoid, water feed	01223015
19	Reservoir lid and sensors (includes screws and o-ring)	01118108
20	Valve, shut-off, water	502921
21	Auger, 710 self-contained (includes seal, key, journal, bolt and auger hardware)	01222686
22	Evaporator, 710	01222694
23	Rear bushing housing and bushing (includes (1) o-ring)	01222710
24	Reservoir assembly, water (includes lid)	01222728
25	Tube, vent (17" required)	502079
26	Tube, cleaner	01118660
27	Kit, MicroChewblet	01161843
28	Tube, shuttle drain, insulated	01118678
29	Solenoid, purge	01222702
30	Insulation kit, 710 evaporator/reservoir	01222769
31	Check valve	01122381
32	Tube, drain, reservoir, insulated	01118124
33	Tube, drain, 710	01099662
34	O-ring, reservoir lid	01302298
Not shown	Kit, scale (includes reservoir, purge solenoid, drain tubes and fitting)	01224815
35	O-ring, MicroChewblet	01161850
Not shown	Drain kit (includes 2 ft. x 1" OD silicone tubing, 3/4" x 1" slip, 3/4" barb 3/4" FPT (2), 3/4" barb x 3/4" FPT elbow)	01210350
36	Journal, threaded	01437532
37	Bolt, journal	01478742

Air-cooled assembly

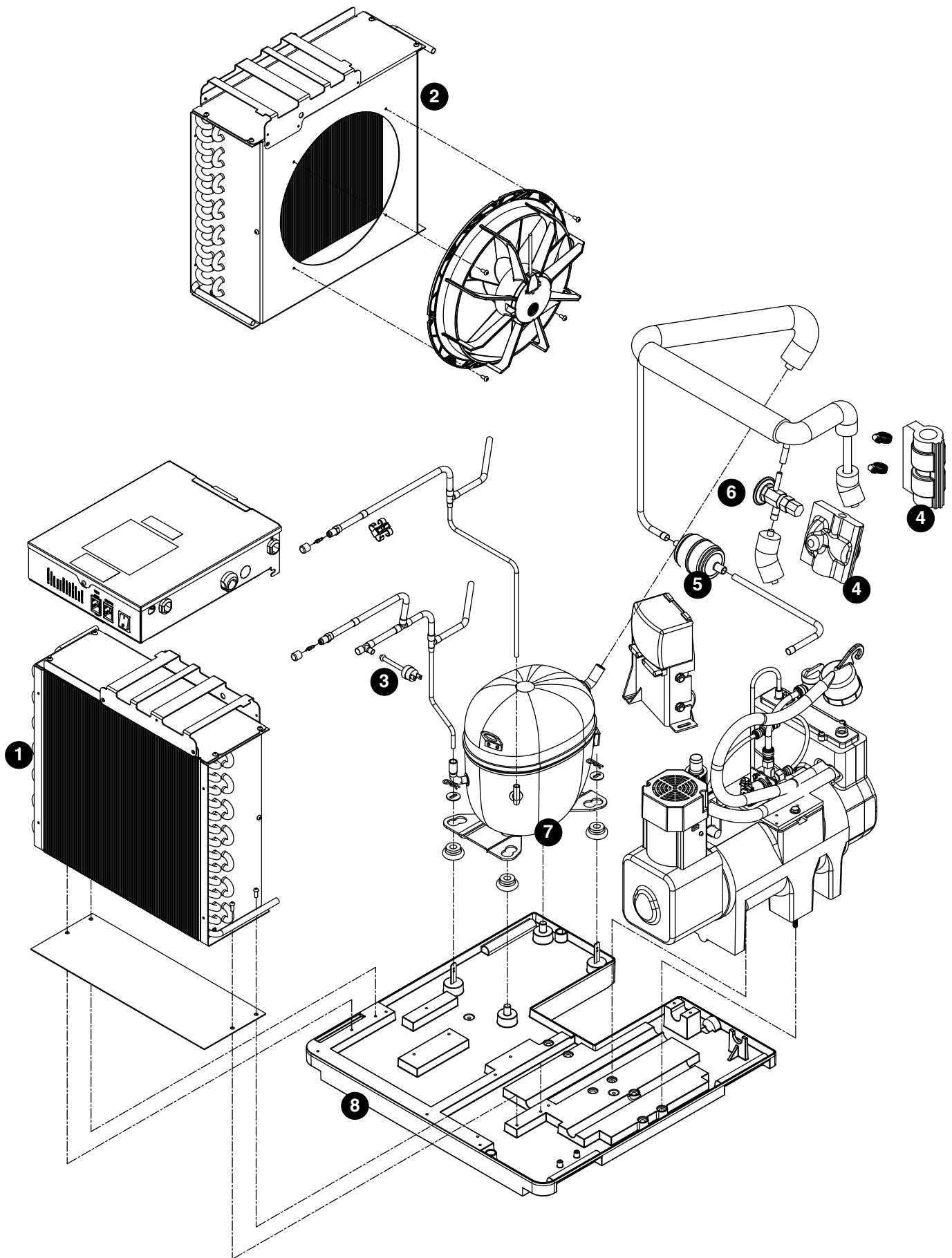

Reference #	Description	Part #
1	Condenser	01222785
2	Fan motor assembly	01222793
3	Cut-out, high pressure safety	01232941
4	Insulation, TXV (body and bulb)	502830
5	Drier	01153683
6	Valve, expansion, thermal (includes insulation and (2) clamps)	01222777
7	Compressor, (includes start/run components and drier)	01222983
8	Base, ice machine	01333772

Electrical box

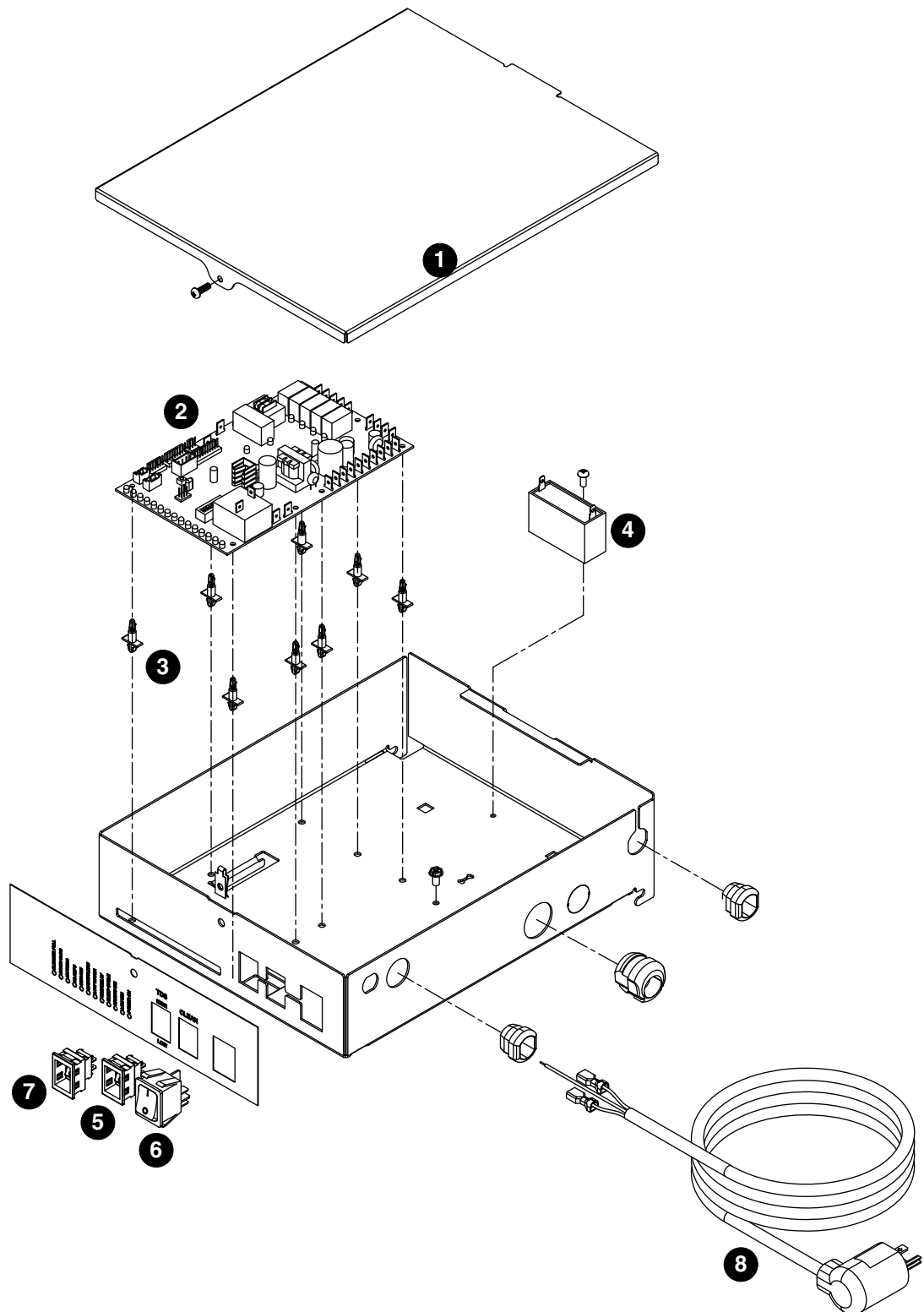

Reference #	Description	Part #
1	Cover, electrical box, air/water-cooled	01118967
2	Board, control (includes stand-offs)	01222827
3	Stand-offs (set of 8)	00130906
4	Supplied with gear motor	
5	Switch, evaporator clean	01165703
6	Switch, ice machine power	01165711
7	Switch, TDS	01165695
8	Cord, power	01302967
Not shown	Contactator	00975136

Integration kit – top-mount and RIDE remote ice delivery

Top mount configuration

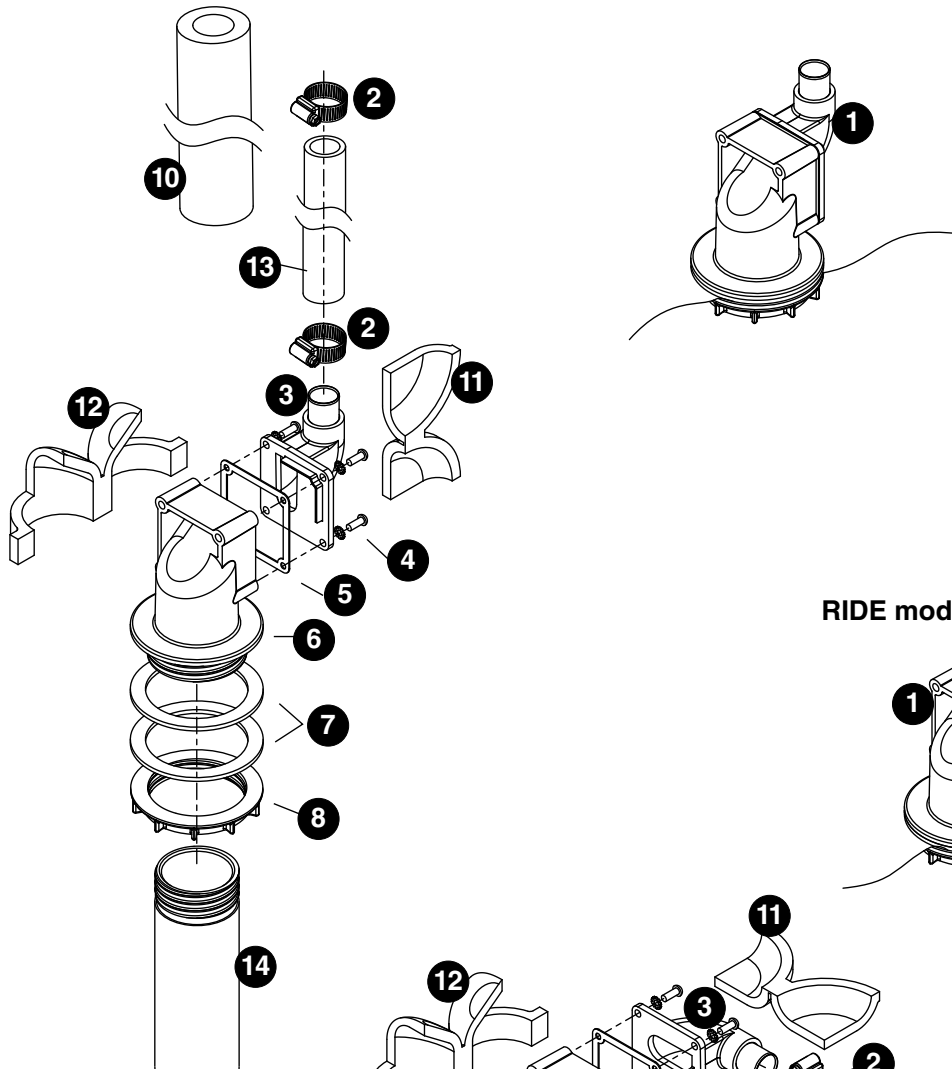

RIDE model configuration

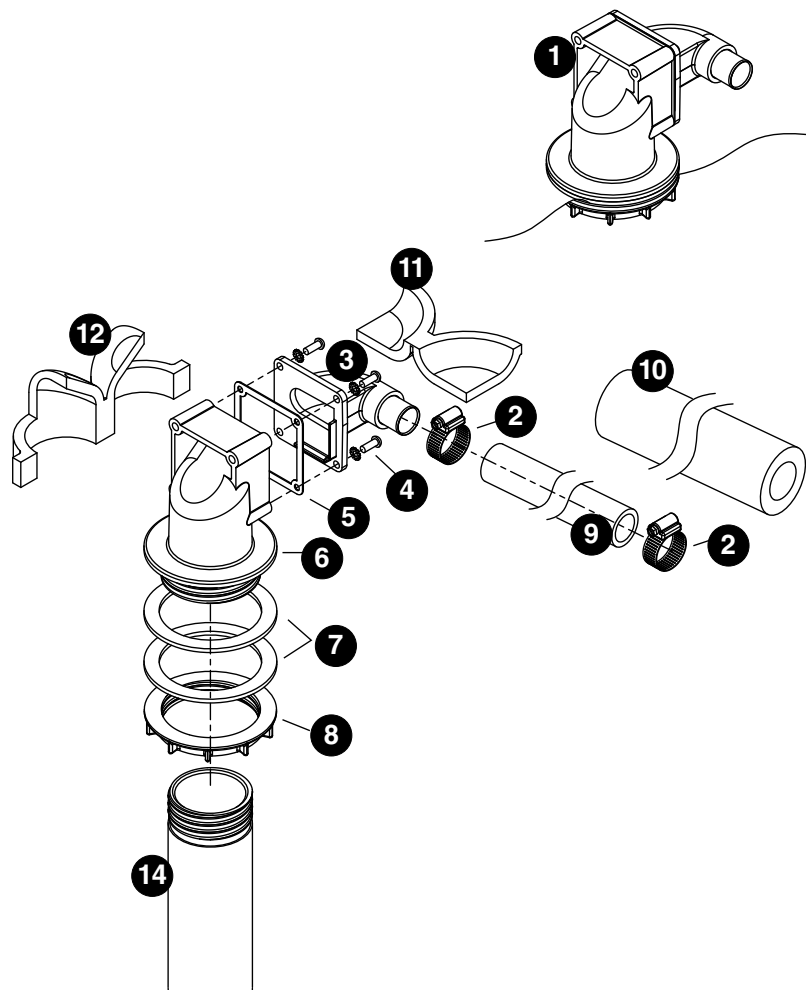

Reference #	Description	Part #
1	Shuttle actuator	00171322
2	Clamp	500377
3	Actuator elbow (includes 00167122 and 209100)	00171264
4	Screws	01303064
5	Gasket	01303072
6	Actuator body	00171272
7	Gasket, coupling	01303080
8	Ring, locking (includes 00126532)	00171371
9	Ice transport tube, 10' (3 m)	00171280
9	Ice transport tube, 20' (6 m)	00171298
10	Insulation, transport tube	501176
Not shown	Insulated polywire ice transport tube, per foot	00174896
11	Insulation, elbow	01303098
12	Insulation, actuator	01303106
13	Ice transport tube, top mount, 30" (762 mm)	00171306
14	Extension-fill tube, 9"	01303114
14	Extension-fill tube, 4"	01303122
Not shown	Integration kit, top mount, Harmony or Bin	00171389
Not shown	Integration kit, RIDE model, Harmony or Bin, (includes 10' (3 m) of tube and insulation)	00171397
Not shown	Integration kit, drop in	00145334
Not shown	Integration kit, Cornelius PR150	00144774
Not shown	Integration kit, Vision (does not include ice tube)	00997171
Not shown	Diverter plate (single agitator Cornelius dispensers and left-hand dispense chute on dual-agitator Cornelius dispensers)	01303130
Not shown	Diverter plate (right-hand dispense chute on dual-agitator dispensers)	00996207
Not shown	SafeCLEAN Plus, case of 6	01149954
Not shown	SafeCLEAN Plus, case of 24	01149962
Not shown	SaniSponge kit	00132068
Not shown	High-capacity filter system	01303148
Not shown	Primary filter (1)	01333814
Not shown	Primary filter (6)	00978973
Not shown	Pre-filter (1)	01333822
Not shown	Pre-filter (12)	00954305
Not shown	IMS III sanitizer concentrate - 16 oz.	00979674
Not shown	Sponge, sanitary, pack of 24	01075431
Not shown	Kit, IMDV (included IMDV cartridge and communication cable)	01116177
Not shown	Tubing, silicone (per foot)	01303155

Skins assembly

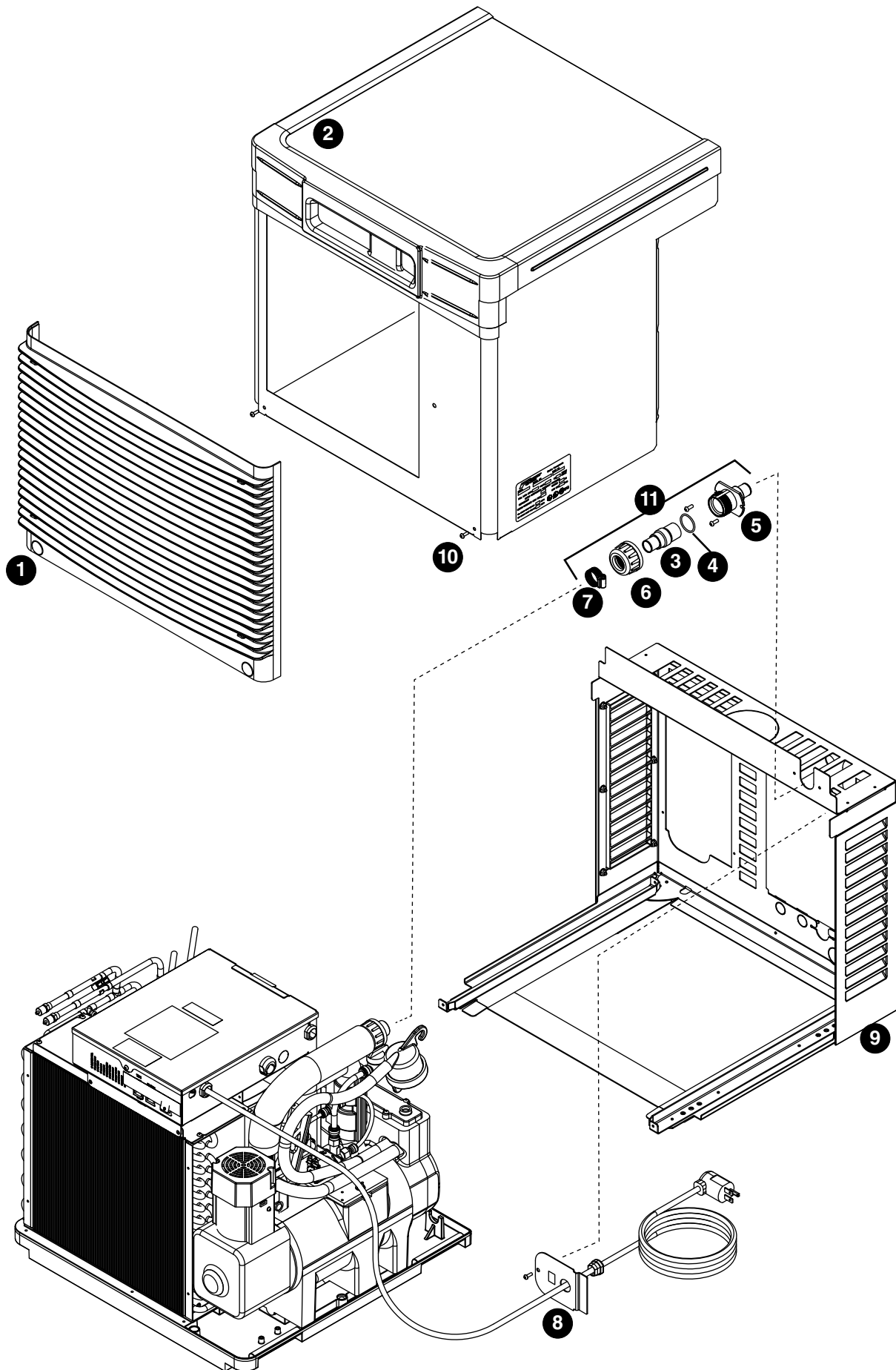

Reference #	Description	Part #
1	Grille, front	01303163
2	Front cover, air-cooled, 710/710	01119007
Not shown	Tubing, water, 3/8" OD	502719
3	Coupling (includes O-ring)	00171207
4	O-ring	01303171
5	Bulkhead fitting	00171215
6	Nut	01303189
7	Hose clamp	500377
8	Plate, strain relief	00192070
9	Louvered docking station, 710 (includes strain relief plate, bulkhead fitting) Serial number preX need to order front cover.	01225952
10	Screw	01303197
11	Bulkhead connector kit	00171223
Not shown	Gasket, front cover (inside), per foot (4 feet required)	00135574
Not shown	Louver, intake/exhaust (25.75" W x 17.75" H)	01085448
Not shown	Gasket, air intake (front cover, outside) (7 feet required)	01305317
Not shown	Fitting, drain	00109728

Registro de Garantía y Evaluación del Equipo

Gracias por haber elegido este producto Follett®. Esperamos que nuestro equipo cumpla o supere sus expectativas porque es nuestro objetivo ofrecer productos y servicios de gran valor que se ganen su plena confianza.

Le rogamos consulte el manual de instalación y de instrucciones adjunto, ya que es muy importante que la instalación se realice según las especificaciones de fábrica para que el equipo funcione a su máxima eficiencia.

Follett LLC no se hace responsable de los daños indirectos, costos, gastos por conexión y desconexión o pérdidas por causa de defecto de la máquina.

Si desea una información más completa sobre la garantía, visite nuestro sitio web www.follettice.com/productwarranties.

Las operaciones de registro de la garantía y evaluación del equipo son importantes para que podamos realizar un seguimiento de nuestro equipo y registrar el rendimiento de la maquinaria. Por favor, registre las garantías del equipo Follett en nuestro sitio web www.follettice.com/support y seleccione Registro de la Garantía y Evaluación del Equipo. Es muy sencillo, solo le llevará un momento realizar hoy mismo el registro. En el formulario incluimos un espacio en blanco para sus comentarios y opiniones. Infórmenos sobre su experiencia para que podamos incorporarla a nuestros continuos esfuerzos de mejora.

Nos enorgullecemos de producir un equipo excepcional y trabajamos duro para respaldarlo con un soporte técnico y un servicio de atención al cliente de primera. Le rogamos nos indique qué más podemos hacer para ayudarlo. Estaremos encantados de responder a sus dudas.

Enregistrement de la garantie et évaluation de l'équipement

Merci d'avoir acheté un équipement Follett®. Notre objectif étant d'offrir des produits et des services de grande valeur vous satisfaisant pleinement, nous espérons que celui-ci satisfera, voire dépassera, vos attentes !

Veuillez consulter le manuel d'installation et d'exploitation. Il est important que l'installation soit réalisée conformément aux spécifications de l'usine, de sorte que votre équipement fonctionne à son rendement maximum.

Follett LLC n'est pas responsable de tout dommage consécutif, de toute dépense, de tout frais de raccordement ou de déconnexion, ni de toute perte liée à un défaut de la machine.

Pour lire la garantie dans son ensemble, visitez notre site Internet www.follettice.com/productwarranties.

L'enregistrement de la garantie et l'évaluation de l'équipement sont importants pour nous aider à suivre notre équipement et pour enregistrer les performances de la machine. Nous vous demandons donc d'enregistrer la garantie de votre équipement Follett sur notre site Internet, www.follettice.com/support, dans la section Warranty Registration and Equipment Evaluation. Cette opération est simple ; veuillez prendre un moment pour la réaliser aujourd'hui.

Le formulaire contient également un espace pour nous faire parvenir vos commentaires et un retour d'informations. Veuillez nous faire part de votre expérience pour que nous puissions prendre appui dessus pour poursuivre nos efforts constants d'amélioration.

Nous sommes fiers de produire des équipements exceptionnels et nous travaillons avec acharnement pour y associer une assistance à la clientèle et technique exceptionnelle. N'hésitez pas à nous indiquer dans quelle mesure nous pouvons vous aider. Nous serions ravis de répondre à vos questions.

Warranty Registration and Equipment Evaluation

Thank you for purchasing Follett® equipment. We hope you find that our equipment meets or exceeds your expectations, as our goal is to deliver high value products and services that earn your complete satisfaction!

Please review the enclosed installation and operations manual. It is important that the installation be performed to factory specifications, so your equipment operates to its maximum efficiency.

Follett LLC will not be liable for any consequential damages, expenses, connecting or disconnecting charges or any losses resulting from a defect of the machine.

For full warranty details, visit our website www.follettice.com/productwarranties.

Warranty registration and equipment evaluation is important to help us keep track of our equipment and to record the machine's performance. We request that you register Follett equipment warranties on our website www.follettice.com/support and choose Warranty Registration and Equipment Evaluation. It's simple to do; please take a moment to register today. There is also space on the form to provide us with comments and feedback. Please let us know about your experience so we can capture it for our continuous improvement efforts.

We pride ourselves on producing outstanding equipment and we work hard to back it up with outstanding customer and technical support.

Please let us know what else we can do to assist you. We would be happy to answer your questions.