

HC_1810R/N, HC_2110R/N, HM_1810R/N, HM_2110R/N Horizon Elite™ Ice Machines (Remote Condensing)

Order parts online
www.follettice.com

Operation and Service Manual After Serial Number R03746

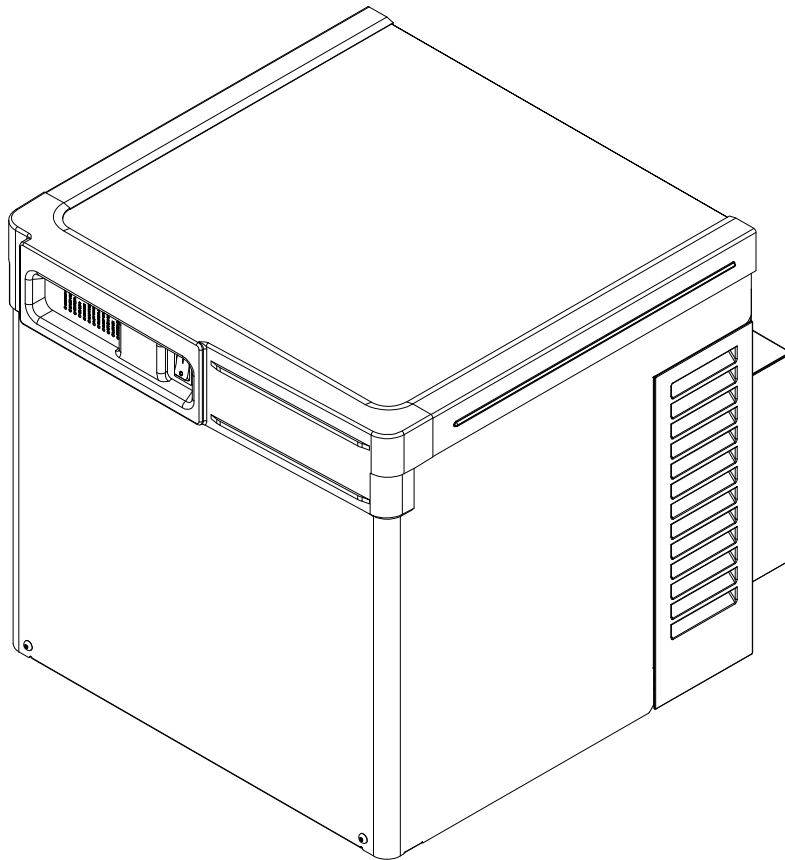

Following installation, please forward this manual
to the appropriate operations person.

Contents

Welcome to Follett	4
Before you begin	4
Specifications	5
Electrical	5
Evaporator unit	5
Condensing unit	5
Evaporator plumbing	5
Flush drain plumbing	5
Ambient	6
Refrigeration	6
Weight	6
Ice production	6
Dimensions and clearances	7
Operation	9
Cleaning/sanitizing and preventive maintenance (all models)	9
Service	13
Ice machine operation (all models)	13
Water system	14
“Bin full” detection system	15
Electrical system	16
Mechanical System	21
Evaporator disassembly	21
Evaporator reassembly	24
Refrigeration system	29
Troubleshooting	32
Replacement parts	34
Evaporator assembly	34
Low-side assembly	36
Electrical box	38
Integration kit – top-mount and RIDE remote ice delivery	40
Skins assembly	42
1810 Single-phase condensing unit	44
2110 Single-phase condensing unit	45
1810 3-phase condensing unit	46
2110 3-phase condensing unit	47

Welcome to Follett

Follett equipment enjoys a well-deserved reputation for excellent performance, long-term reliability and outstanding after-the-sale support. To ensure that this equipment delivers the same degree of service, we ask that you review the installation manual (provided as a separate document) before beginning to install the unit. Our instructions are designed to help you achieve a trouble-free installation. Should you have any questions or require technical help at any time, please call our technical service group at (877) 612-5086 or +1 (610) 252-7301.

Before you begin

After uncrating and removing all packing material, inspect the equipment for concealed shipping damage. If damage is found, notify the shipper immediately and contact Follett LLC so that we can help in the filing of a claim, if necessary.

Check your paperwork to determine which model you have. Follett model numbers are designed to provide information about the type and capacity of Follett equipment. Following is an explanation of the different model numbers in the series.

Chewblet® Ice Machine Model Number Configurations

Icemaker	Voltage	Series	Condenser	Application	Configuration
MC Maestro™ Chewblet® (425 Series)	C 208-230/60/1 (icemaking head) <i>Self-contained only.</i>	425 up to 425 lbs (193 kg)	A Air-cooled, self-contained W Water-cooled, self-contained	V Vision™ H Harmony™	S RIDE™ (RIDE remote ice delivery equipment)
HC Horizon Chewblet (710, 1010, 1410, 1810, 2110 Series)	D 115/60/1 (icemaking head) <i>Self-contained and remote. If remote unit, high side is 208-230/60/1.</i>	710 up to 675 lbs (306 kg)	R Air-cooled, remote condensing unit N Air-cooled, no condensing unit for connection to parallel rack system	J Drop-in M Ice Manager diverter valve system	T Top-mount
HM Horizon Micro Chewblet	E 230/50/1 (icemaking head) <i>Self-contained only.</i> F 115/60/1 (icemaking head) <i>Remote only. High side is 208-230/60/3.</i>	1010 up to 1061 lbs (482 kg) 1410 up to 1466 lbs (665 kg) 1810 up to 1790 lbs (812 kg) 2110 up to 2039 lbs (925 kg)		P Cornelius Profile PR150	

CAUTION

- Warranty does not cover exterior or outside installations.
- Moving parts. Do not operate with front cover removed.
- Hot parts. Do not operate with cover removed.
- To reduce risk of shock, disconnect power before servicing.
- Drain line must not be vented.
- Water supply must have particle filtration.
- Most ice machine cleaners contain citric or phosphoric acid, which can cause skin irritation. Read caution label on product and follow instructions carefully.
- Ice is slippery. Maintain counters and floors around dispenser in a clean and ice-free condition.
- Ice is food. Follow recommended cleaning instructions to maintain cleanliness of delivered ice.

Specifications

Electrical

Separate, dedicated circuit and equipment ground required.

Evaporator unit

Standard electrical: 115/60/1

Maximum fuse: 15A

Amperage: 5A

Condensing unit

	1810 Single-Phase	1810 3-Phase	2110 Single-Phase	2110 3-Phase
Electrical	208-230V, 60Hz			
Max Circuit HVACR breaker size	45A	25A	45A	30A
Min Circuit Ampacity	26.2A	15.7A	27.1A	19.9A

Evaporator plumbing

- 3/8" OD push-in water inlet - 3/8" OD tubing required.
- Water shut-off recommended within 10 feet (3 m).
- Follett recommends installation of Follett water filter system (part# 00130286) in ice machine inlet water line.

Flush drain plumbing

- 3/4" MPT flush drain connection at the rear of the machine.
- Drain must slope 1/4" per foot (6 mm per 30.4 cm).
- Drain line should not be shared with any other piece of equipment.
- Drain line cannot be reduced to a size smaller than 1".
- Drain should be piped without a vent.

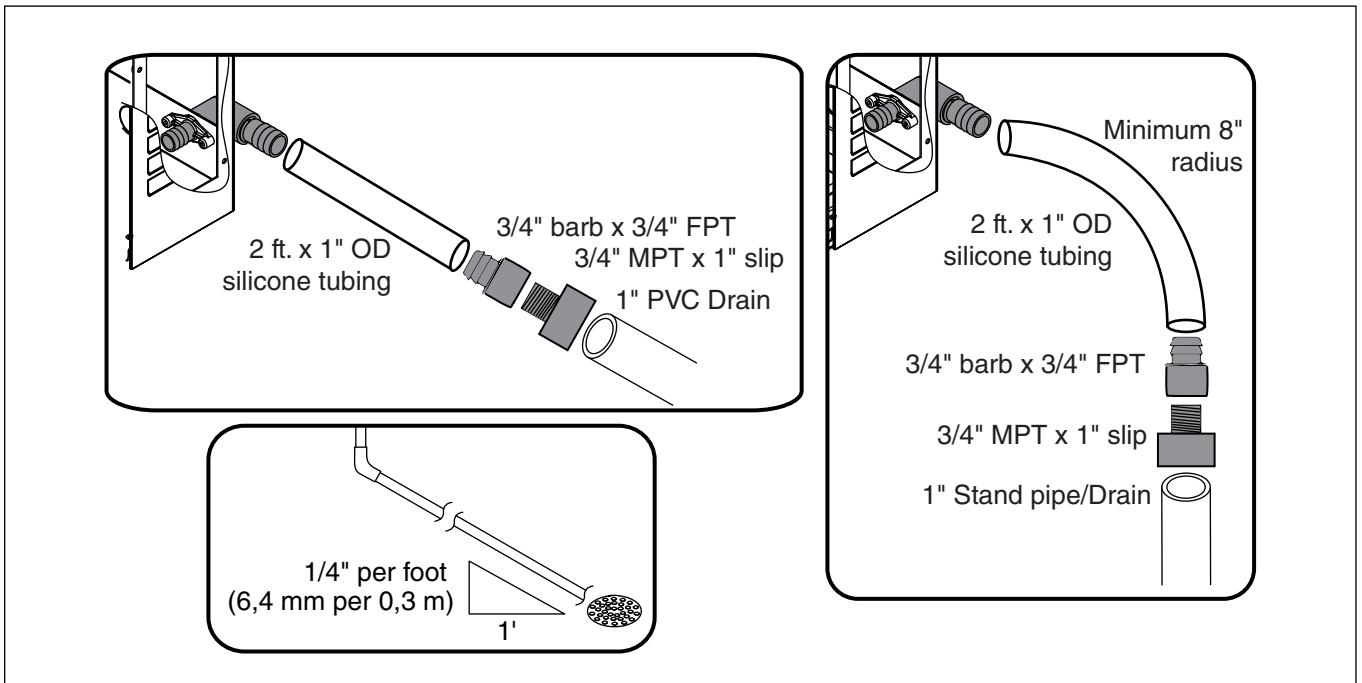

Chassis drain plumbing

- Plug must be removed from John Guest fitting.
- Route 3/8" drain tubing through knockout in back of docking station and insert fully into John Guest fitting connection at the rear of the machine chassis. Route other end of 3/8" drain tubing to drain.
- Drain must slope 1/4" inch per foot (6 mm per 30.4 cm).

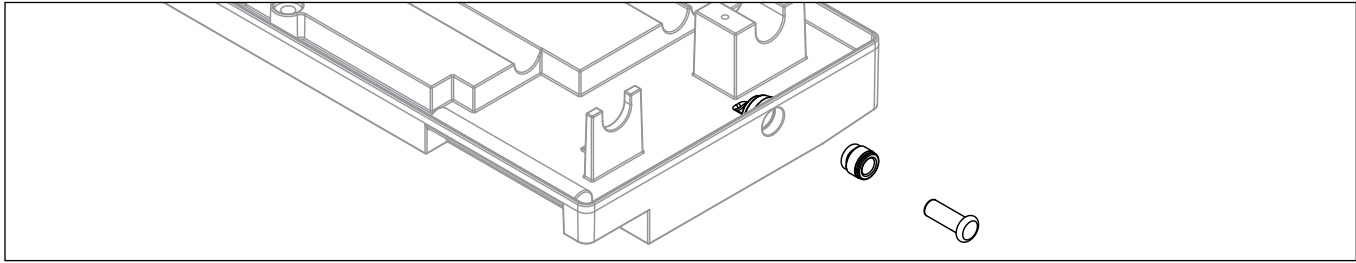

Ambient

Evaporator unit

Air temperature	100 F/38 C max.	50 F/10 C min.
Water temperature	90 F/32 C max.	45 F/7 C min.
Water pressure	70 psi max. (483 kPa)	10 psi min. (69 kPa)

Condenser unit

Air temperature	120 F/49 C max.	-20F/-29C min.
-----------------	-----------------	----------------

Refrigeration

- 3/8" liquid line
- 7/8" suction line

Note: Rack system installations require a capacity of 15,700 BTU/hr for 1810 machines and 18,200 BTU/hr for 2110 machines at 0 F (-18 C) evaporator temperature. Evaporator pressure regulator (not supplied) is required.

Weight

Evaporator unit:

1810: 157 lbs (71.2 kg)

2110: 165 lbs (74.8 kg)

Condensing unit: 305 lbs (138.3 kg)

Ice production

1810 ice machine capacity/24 hrs.

		Ambient Air Temperature F/C						
		F	60	70	80	90	100	
Evap Potable Water Temperature F/C	C	16	21	27	32	38		
	50	1859	1784	1685	1616	1500	lbs	
	10	843	809	764	733	680	kg	
	60	1723	1684	1578	1563	1409	lbs	
	16	782	764	716	709	639	kg	
	70	1620	1594	1514	1420	1319	lbs	
	21	734	723	687	644	598	kg	
	80	1550	1487	1485	1351	1299	lbs	
	27	703	674	674	613	589	kg	
	90	1471	1435	1370	1285	1207	lbs	
	32	667	651	621	583	547	kg	

2110 ice machine capacity/24 hrs.

		Ambient Air Temperature F/C						
		F	60	70	80	90	100	
Evap Potable Water Temperature F/C	C	16	21	27	32	38		
	50	2039	2039	1934	1825	1703	lbs	
	10	925	925	877	828	772	kg	
	60	1943	1888	1878	1710	1584	lbs	
	16	881	856	852	772	718	kg	
	70	1833	1781	1689	1634	1489	lbs	
	21	831	808	811	741	675	kg	
	80	1754	1686	1643	1535	1426	lbs	
	27	796	765	745	696	647	kg	
	90	1650	1603	1577	1457	1395	lbs	
	32	748	727	715	661	633	kg	

Dimensions and clearances

- Entire front of ice machine must be clear of obstructions/connections to allow removal.
- 1" (26mm) clearance above ice machine for service.
- 1" (26mm) minimum clearance on sides.

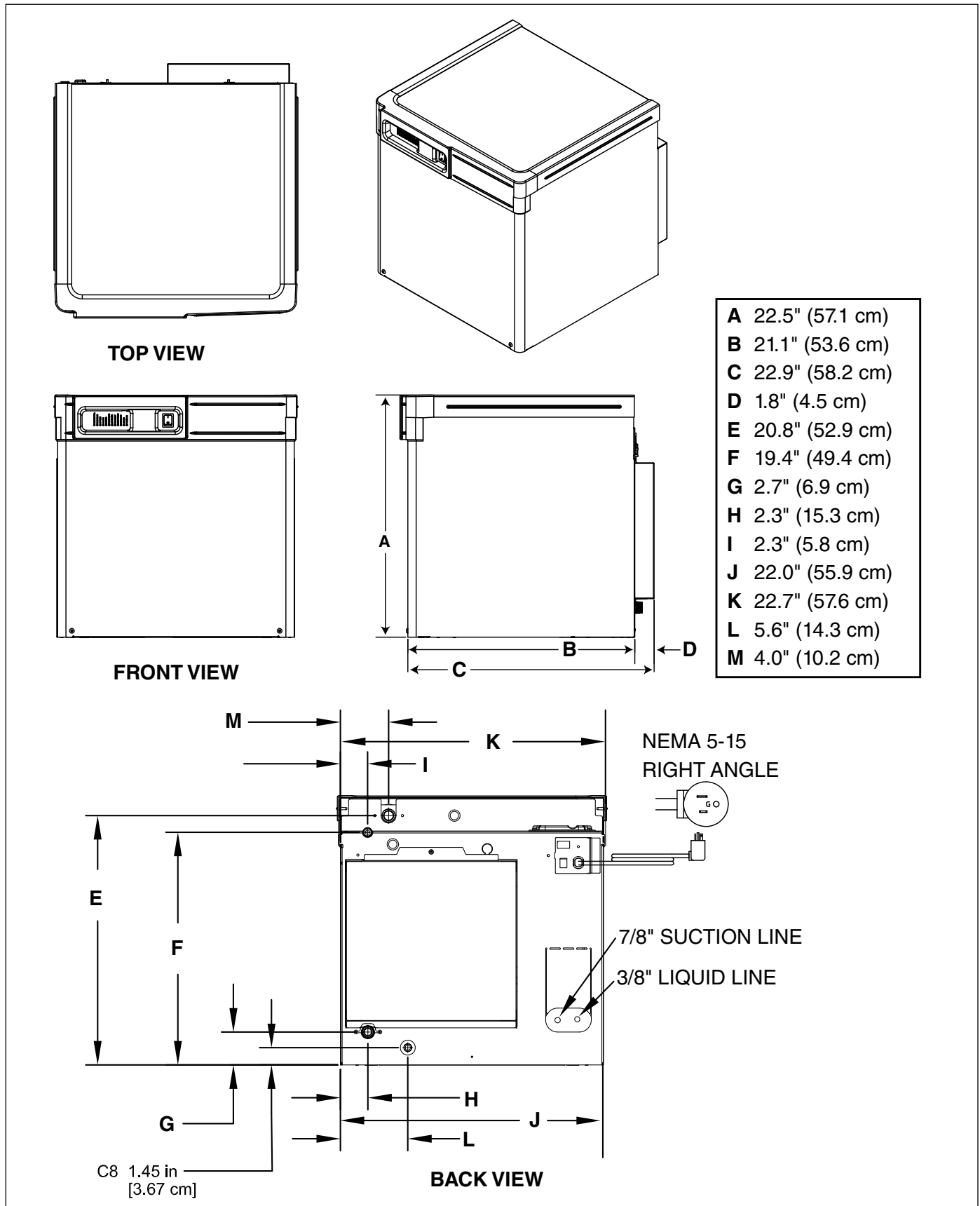

Condensing unit

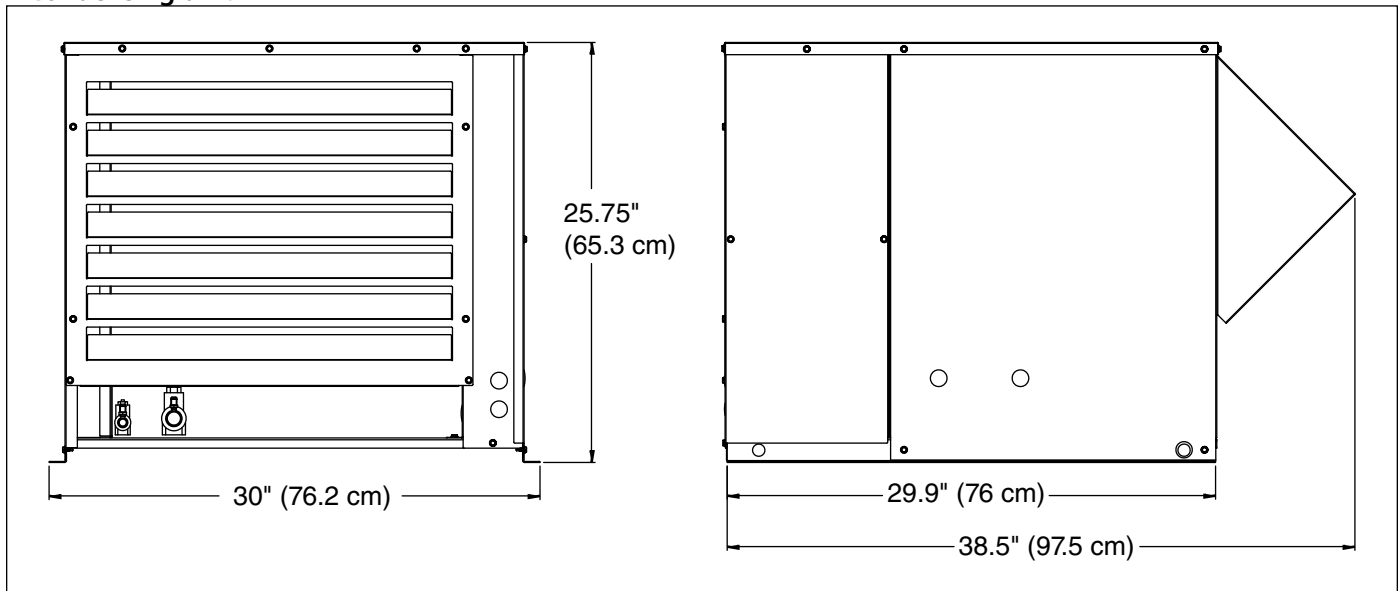

2. Follow the directions on the SafeCLEAN Plus packaging to mix 1 gal. (3.8 L) of Follett SafeCLEAN Plus solution. Use 120 F (49 C) water.
3. Using a 1 quart (1 L) container, slowly fill cleaning cup until CLEANER FULL light comes on and cleaner just begins to flow from the vent tube.
4. Place two SaniSponge™ cleaning sponges in remaining sanitizing and cleaning solution and retain for Step 9.

Note: Do not use bleach to sanitize or clean the icemaker.

Fig. 2

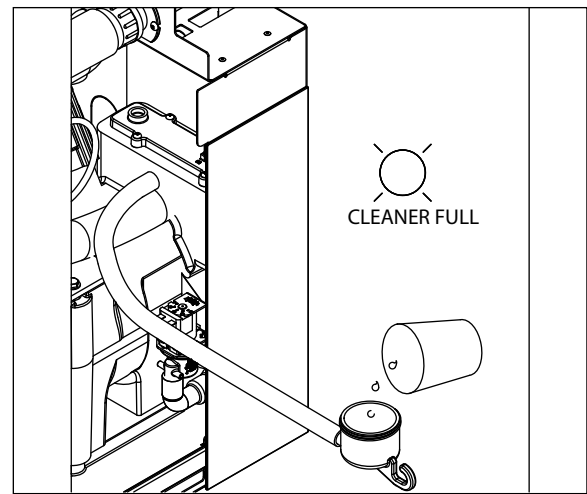

5. Replace cover on cleaner cup. Machine will clean, then flush 3 times in approximately 15 minutes. Wait until machine restarts.

Fig. 3

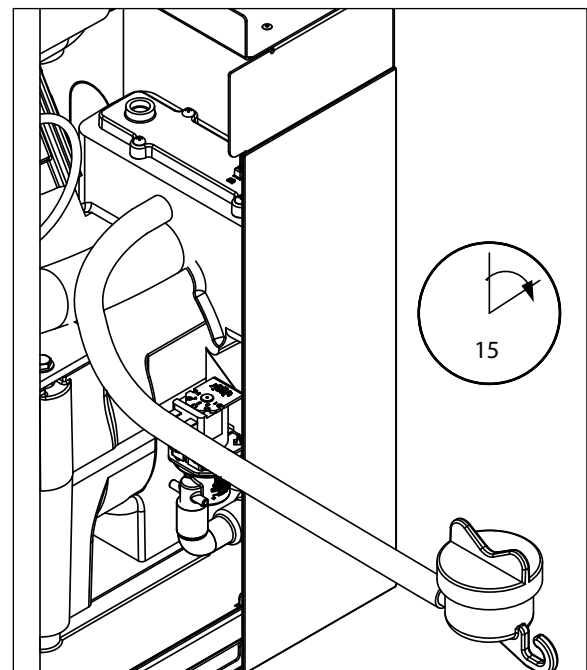

6. To clean/sanitize ice transport tube – Press power switch OFF

Fig. 4

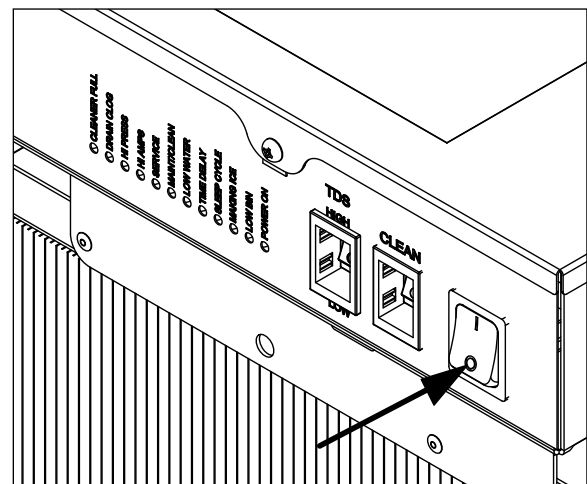

7. Disconnect coupling as shown.

Fig. 5

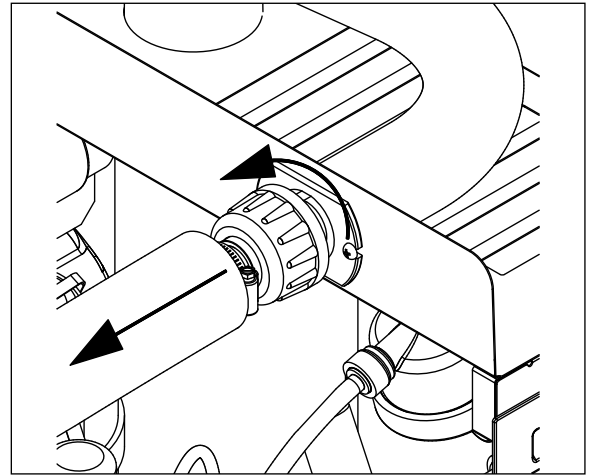

- 8. Using disposable foodservice grade gloves, insert both SaniSponge cleaning sponges saturated in SafeClean Plus (from Step 4).
- 9. Push both SaniSponge cleaning sponges down ice transport tube with supplied pusher tube.

Fig. 6

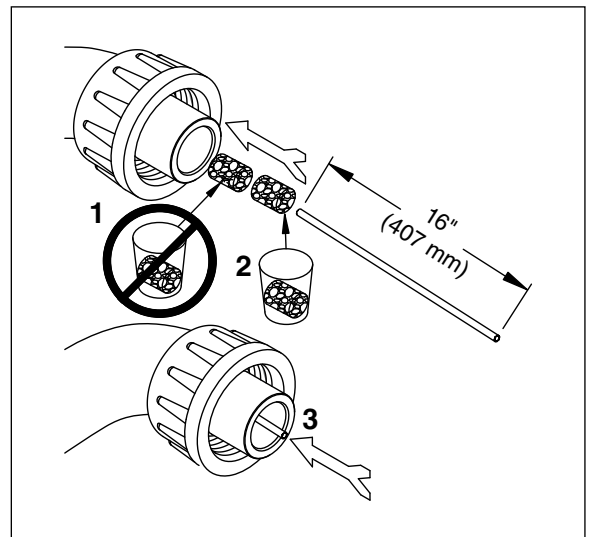

10. Remove and discard 16 inch (407 mm) pusher tube.

Fig. 7

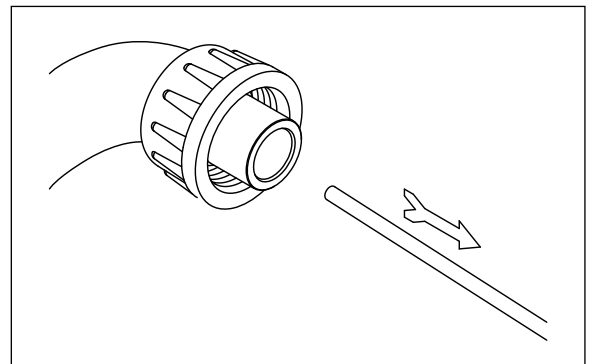

- 11. Reconnect coupling. Press power switch ON. Ice pushes Sani-Sponges through ice transport tube.

Fig. 8

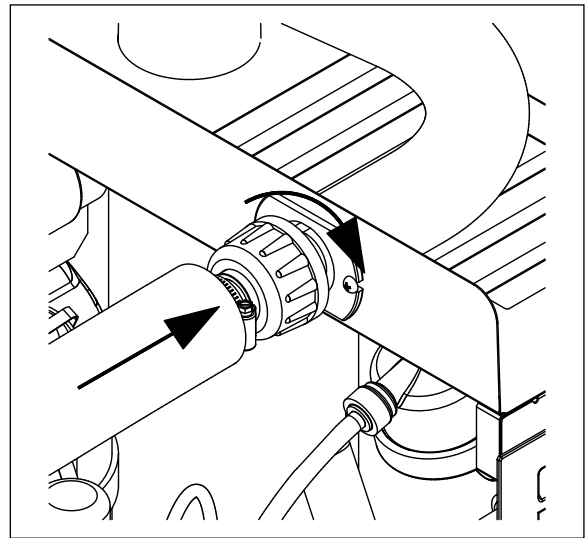

- 12. Place a sanitary (2 gal. or larger) container in bin or dispenser to collect SaniSponge cleaning sponges and ice for 10 minutes after the Sani-Sponges come out.
- 13. Discard ice and Sani-Sponges. Return TDS switch to the original position.

Fig. 9

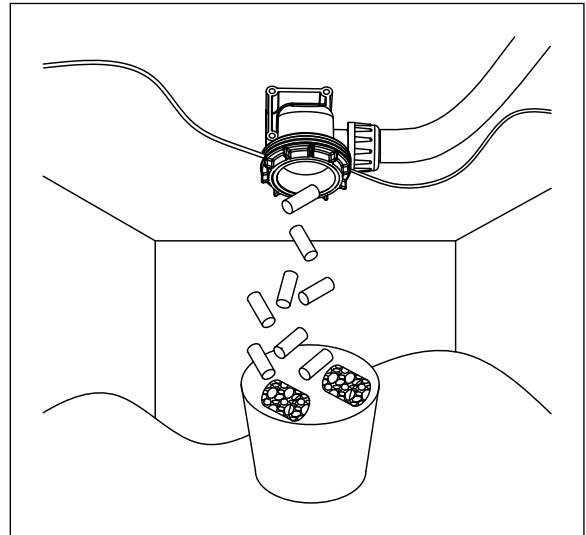

Service

Ice machine operation (all models)

Follett's ice machine consists of five distinct functional systems covered in detail as follows:

- Water system
- Electrical control system
- Mechanical assembly
- Refrigeration system
- Bin full

The Horizon ice machine overview

The Follett Horizon ice machine uses a horizontal, cylindrical evaporator to freeze water on its inner surface. The refrigeration cycle is continuous; there is no batch cycle. The evaporator is flooded with water and the level is controlled by sensors in a reservoir. A rotating auger (14 RPM) continuously scrapes ice from the inner wall of the evaporator. The auger moves harvested ice through the evaporator into an ice extrusion canal. The ice is forced through a restrictive nozzle that squeezes out the water and creates the Chewblet. The continuous extrusion process pushes the Chewblets through a transport tube into a dispenser or bin.

A solid state PC board controls and monitors the functionality of the ice machine. In addition to sequencing electrical components, the board monitors various operational parameters. A full complement of indicator lights allows visual status of the machine's operation. Additionally, the PC board controls the self-flushing feature of the ice machine. The evaporator water is periodically drained and replenished to remove minerals and sediment.

A unique "bin full" detection system is incorporated in the Horizon ice machine. A switch located at the ice discharge port of the machine detects the position of the transport tube. When the bin fills up with ice, the transport tube moves out of the normal running position, and the switch turns the ice maker off. A domed housing at the end of the transport tube contains the ice extrusion loads during shut down.

Harvest system diagram

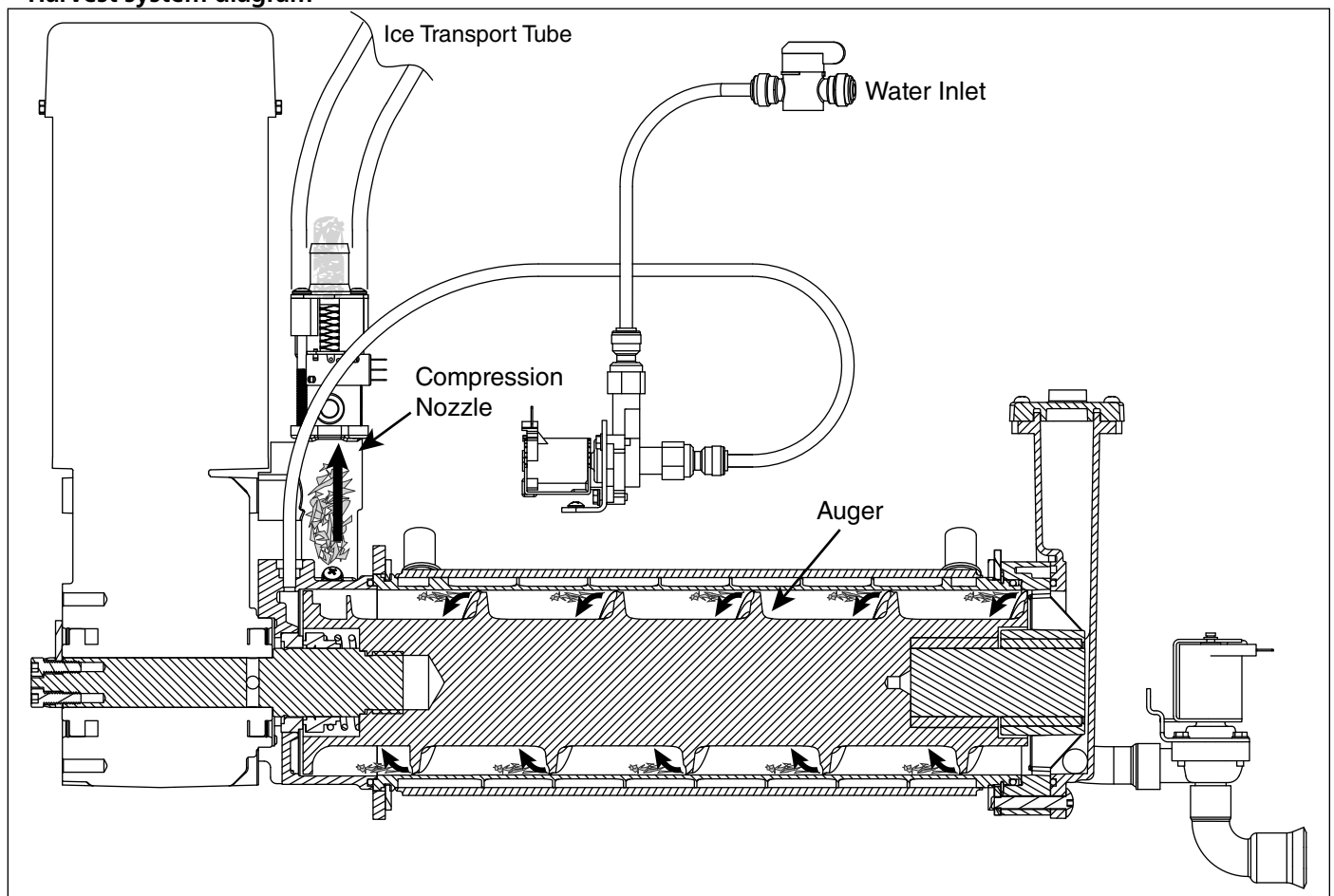

Water system

The water level in the evaporator is controlled by a feed solenoid and level detecting sensors. Referencing the diagram below, water sensing probes extend down into the reservoir at the end of the evaporator assembly. The system works via electrical conductivity as follows:

The probe labeled B is the common. When water is between any of the other probes and the common, the PC board will sense the activation. During normal operation, the water level rises and falls between the Normal High and Normal Low probes. As water is consumed to make ice, the level will fall until the Normal Low probe is exposed, triggering the water feed solenoid on. Water will fill until the Normal High sensor is activated.

Note: The potable water total dissolved solids (TDS) content must be greater than 10 ppm for the water control system to function properly. If using reverse osmosis water filtration system, ensure TDS level is greater than 10 ppm.

Water system diagram

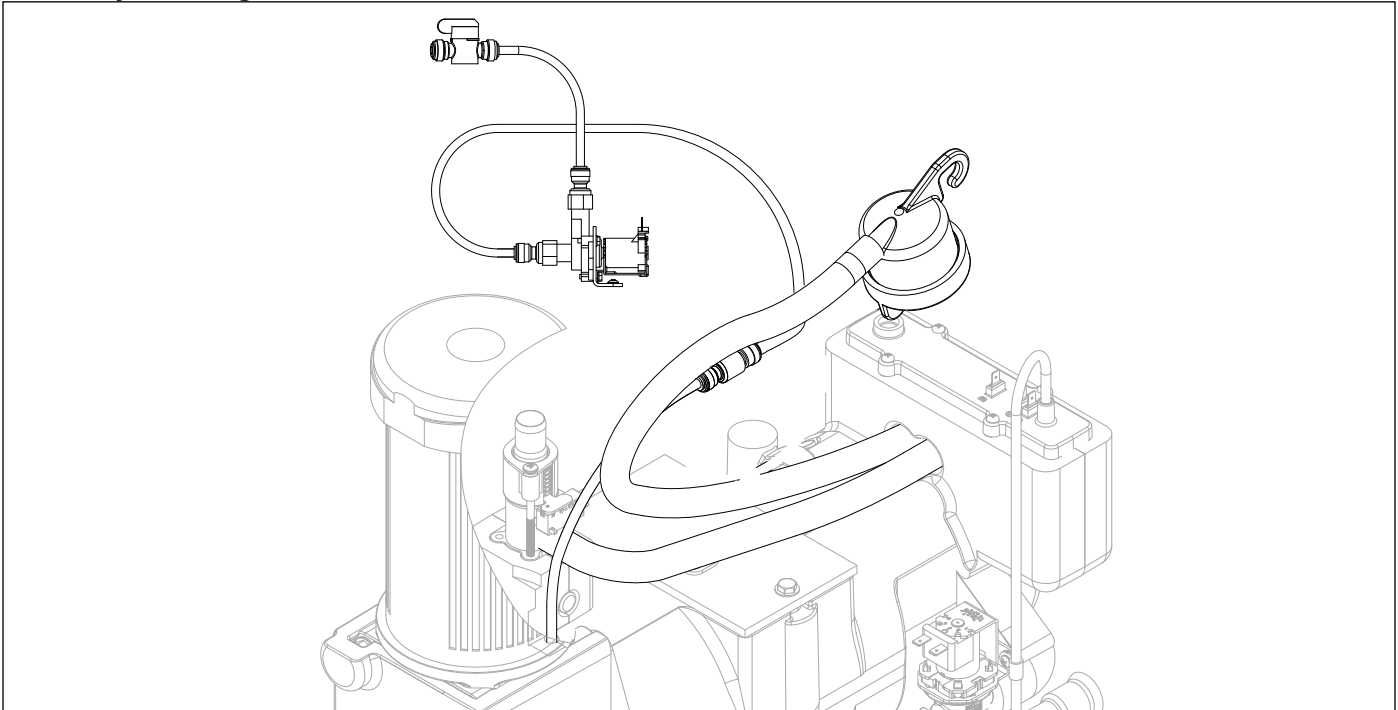

Water level diagram

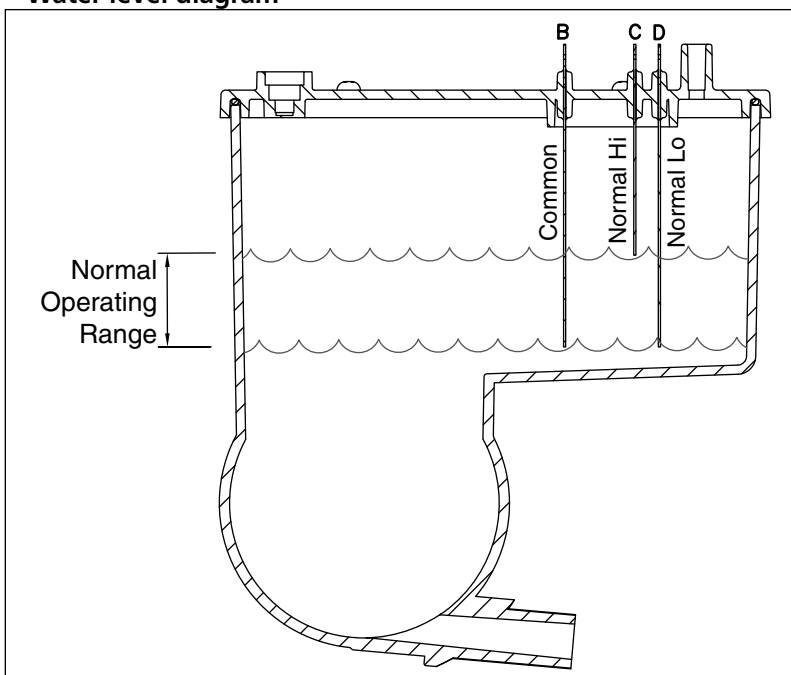

“Bin full” detection system

The Follett Horizon ice machine incorporates a unique “bin full” detection system that consists of the shuttle and actuator. The shuttle incorporates a flag and switch. Referencing the figure below, the normal running position of the flag is down, and the switch is closed. When the bin fills to the top and ice can no longer move through the tube, the machine will force the shuttle flag up, opening the switch and shutting the machine off. The shuttle actuator, located above the ice bin allows the ice to curl up within it when the bin is full. In this way, there are no loads generated that would tend to lift off the lid of the bin.

Shuttle flag and sensor

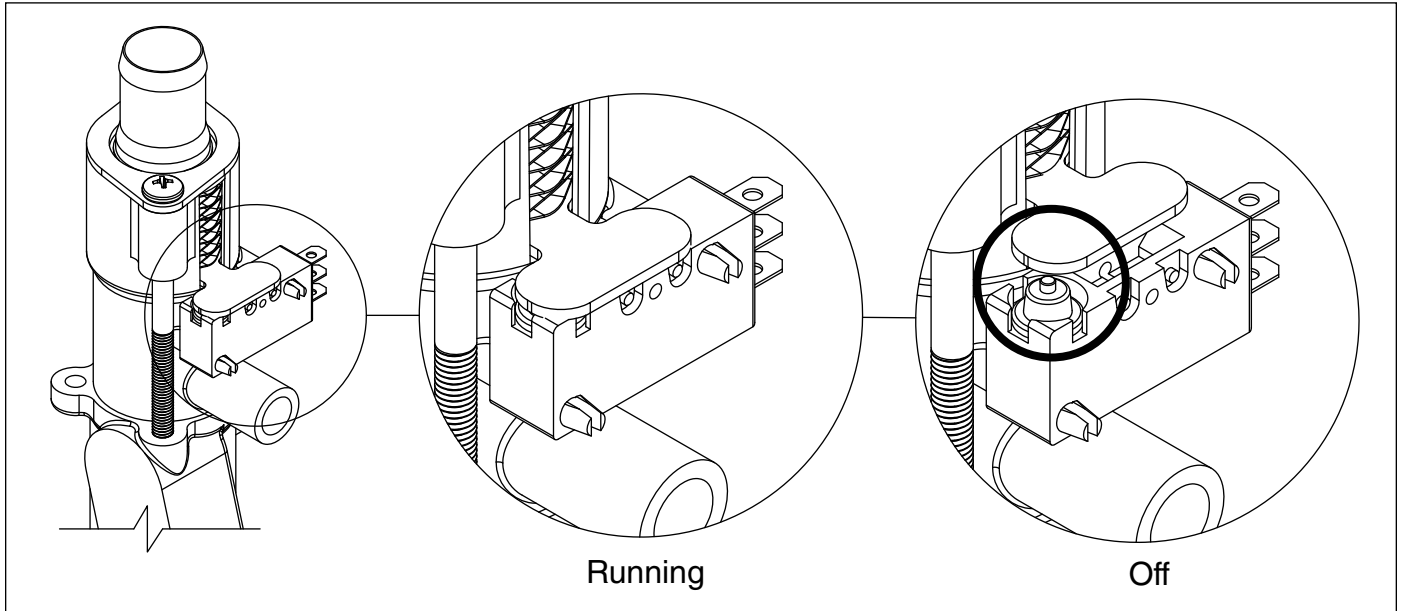

Shuttle actuator

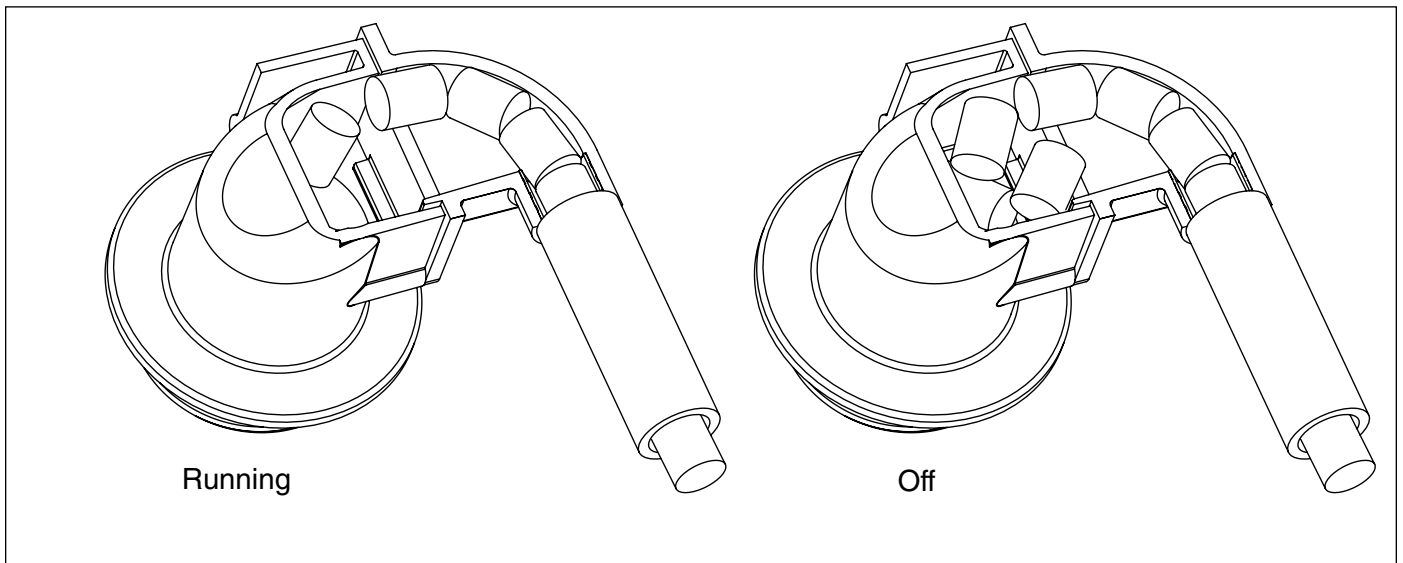

Electrical system



ATTENTION!

To prevent circuit breaker/Hi-amp overload, wait 5 minutes before restarting this unit. This allows the compressor to equalize and the evaporator to thaw.

Normal control board operation

The PC board indicator lights provide all the information necessary to determine the machine's status. Green indicator lights generally represent "go" or normal operation; Yellow indicators represent normal off conditions; Red indicators generally represent alarm conditions, some of which will lock the machine off.

A flashing green light labeled POWER indicates power to the machine. All other normal operation status indicators are covered as follows:

Ice machine disposition	Operating conditions
Legend: ● ON ○ OFF ◐ ON or OFF ✦ FLASHING	
1. Ice machine is making ice. CLEANER FULL ○ DRAIN CLOG ○ HI PRESS ○ HI AMPS ○ SERVICE ○ MAINT/CLEAN ○ LOW WATER ○ TIME DELAY ○ NOT USED ○ MAKING ICE ● LOW BIN ● POWER ON ✦	1. Normal running.
2. Ice machine is not making ice. CLEANER FULL ○ DRAIN CLOG ○ HI PRESS ○ HI AMPS ○ SERVICE ○ MAINT/CLEAN ○ LOW WATER ○ TIME DELAY ● NOT USED ○ MAKING ICE ○ LOW BIN ● POWER ON ✦	2. Normal time delay. When the bin fills with ice, the LOW BIN light goes out momentarily and the refrigeration and auger drive systems immediately shut down. (Note: The fan motor will continue to run for 10 minutes to cool condenser) The TIME DELAY light comes on, initiating the time delay period. When the time delay expires, the machine will restart provided that the LOW BIN light is on.
3. Ice machine is not making ice. CLEANER FULL ○ DRAIN CLOG ○ HI PRESS ○ HI AMPS ○ SERVICE ○ MAINT/CLEAN ○ LOW WATER ○ TIME DELAY ● NOT USED ○ MAKING ICE ○ LOW BIN ● POWER ON ✦	2. Normal Sleep Cycle. On power-up, the ice machine will make ice normally until the bin is full and then enter a normal time delay for 1 hour. At the end of time delay, the machine will begin monitoring the height of the ice pile using a thermostat. If the ice pile has fallen more than 7 inches from the top of the bin, the machine will immediately enter MAKING ICE mode. If the pile has fallen less than 7 inches the TIME DELAY LED will go off and the SLEEP CYCLE LED will light.

DIP Switch Settings

	OFF	ON	
SET TO OFF	<input checked="" type="checkbox"/>	<input type="checkbox"/>	NOT USED
SET TO OFF	<input checked="" type="checkbox"/>	<input type="checkbox"/>	NOT USED
SET TO OFF	<input checked="" type="checkbox"/>	<input type="checkbox"/>	NOT USED
SET TO OFF	<input checked="" type="checkbox"/>	<input type="checkbox"/>	NOT USED
SET TO OFF	<input checked="" type="checkbox"/>	<input type="checkbox"/>	NOT USED
IMDV	<input checked="" type="checkbox"/>	<input type="checkbox"/>	IMDV-2CM and all other applications
Flush disabled	<input checked="" type="checkbox"/>	<input type="checkbox"/>	Flush enabled
Maintenance timer ON	<input checked="" type="checkbox"/>	<input type="checkbox"/>	Maintenance timer OFF

Bin Top Sleep Cycle DIP Switch Setting

	OFF	ON
<input checked="" type="checkbox"/>	<input type="checkbox"/>	<input type="checkbox"/>
<input type="checkbox"/>	<input checked="" type="checkbox"/>	<input type="checkbox"/>
<input type="checkbox"/>	<input checked="" type="checkbox"/>	<input type="checkbox"/>
<input checked="" type="checkbox"/>	<input type="checkbox"/>	<input type="checkbox"/>
<input type="checkbox"/>	<input checked="" type="checkbox"/>	<input type="checkbox"/>
<input type="checkbox"/>	<input checked="" type="checkbox"/>	<input type="checkbox"/>
<input type="checkbox"/>	<input checked="" type="checkbox"/>	<input type="checkbox"/>
<input type="checkbox"/>	<input checked="" type="checkbox"/>	<input type="checkbox"/>

Error faults:

The Horizon PC board monitors various operating parameters including high pressure, auger gearmotor amperage limits, clogged drain, and low water alarm conditions. There are three types of errors namely "soft" (time delay) "hard" (reset), and "run".

- Soft errors will automatically reset after the 1 hour time delay or can be reset by cycling power.
- Hard errors must be reset on the control board.
- Run errors will give an indication of a problem, but will allow continuous normal operation.

Soft errors:

HI AMPS: The PC board monitors the amperage of the auger motor. Should the gear motor experience current draw above the allowable limit, the machine will shut down and the TIME DELAY and HI AMP will be illuminated. After the time delay the machine will restart and the TIME DELAY and HI AMP will clear.

LO WATER: During operation, the water level cycles between the normal low and normal high sensors. Should the water be shut off to a running machine, a soft error will occur. The error sequence is as follows: During operation, the water level falls to the normal low sensor, and when it does the water feed solenoid is energized. If water is not detected at the normal low sensor within 10 seconds, a soft error will occur. The machine will shut down on a low water/time delay error. Should water return, it will fill to the normal low sensor and the machine will resume operation once the 1 hour time delay expires.

HI PRESSURE: Should the refrigeration pressure rise above 425 psi, the machine will shut down and the TIME DELAY and HIGH PRESSURE will be illuminated. After the time delay, and if the pressure has fallen back below the reset point of 295 psi, the machine will restart and the TIME DELAY and HIGH PRESSURE will clear.

Water feed error: While in making ice mode, if the water level does not fall below the low probes for 9 minutes, the machine will enter a 1-hour time delay soft error with the LOW WATER light flashing. After the time delay expires, the machine will try to make ice.

SERVICE: The sensor, located in the chassis will detect the presence of water just below the top edge of the chassis.

Hard error:

HI AMPS will light as a hard error if the gearmotor circuit is open (zero current draw). Press reset on the control board to clear this error.

Run errors:

DRAIN CLOG: When the machine shuts down on a full bin and there has been 30 minutes of cumulative compressor run time, the machine will purge before starting. During this purge, if water does not get below the low probe in the reservoir within 20 seconds, the Drain Clog LED will light. The machine will continue to run but this is an indication of a poorly draining machine and must be addressed.

Relay output indication:

Each relay on the board has an indicator light associated with its output. For example, when the relay for the water feed solenoid is energized, the adjacent indicator light glows green.

Evaporator flushing sequence:

During operation, the purge solenoid will open in order to drain water. There are two drain settings to choose from: High TDS or Low TDS. (There is a rocker switch behind the front cover of the machine.) The intent is to drain the Total Dissolved Solids from the machine while it makes ice.

While ice is being made, the TDS of the water in the evaporator increases in TDS concentration. Without periodic draining, the TDS levels will climb to very detrimental levels, levels that will cause scale to form and cause poor machine operation. The Low TDS setting will allow the machine to operate for one hour before going through the flushing sequence; the High TDS setting will allow the machine to run for 10 minutes before going through the flushing sequence.

The flushing sequence toggles the purge and fill solenoids three times. That is, the purge solenoid will energize until the water level drops below the low probe. The fill solenoid then energizes until water reaches the high probe, and so on for 3 cycles.

Typically, High TDS might be considered levels above 200 PPM, but local experience and varying water chemistry may compel a High TDS setting for best performance in even lower TDS levels.

Off cycle: At the completion of off-cycle time delay, the machine checks for a cumulative 30 minutes of ice making time since the last off-cycle flush. If the cumulative ice making time exceeds 30 minutes, the machine will open the drain valve for 60 seconds to drain the evaporator in its entirety. It will then refill with water and begin making ice. If the ice making time is less than 30 minutes, the machine will start and begin making ice without draining the evaporator.

Wiring diagram, evaporator unit

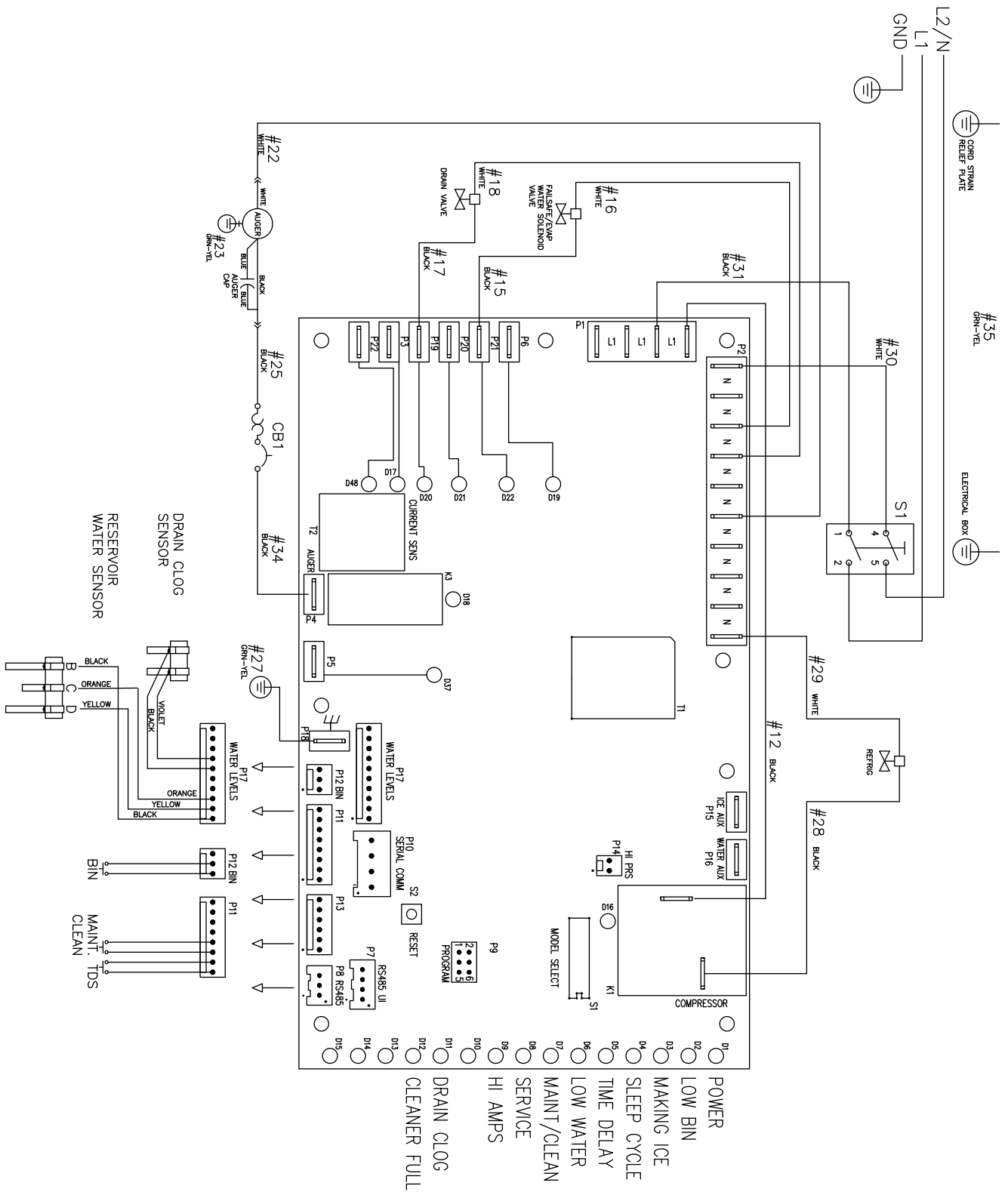

Gearmotor data
 Gearmotor current 4.0A @ 115 V
 Gearmotor torque-out (high amp) trip point: 7.0A

Single-phase condensing unit wiring diagram

208-230V/1/60Hz

(Danfoss MTZ36-1AV) MOP = 45; MCA = 26.2
 (Danfoss MTZ44-1AV) MOP = 45; MCA = 27.1

CIRCUIT BREAKER (by others)

45A for MTZ36-1AV
 45A for MTZ44-1AV

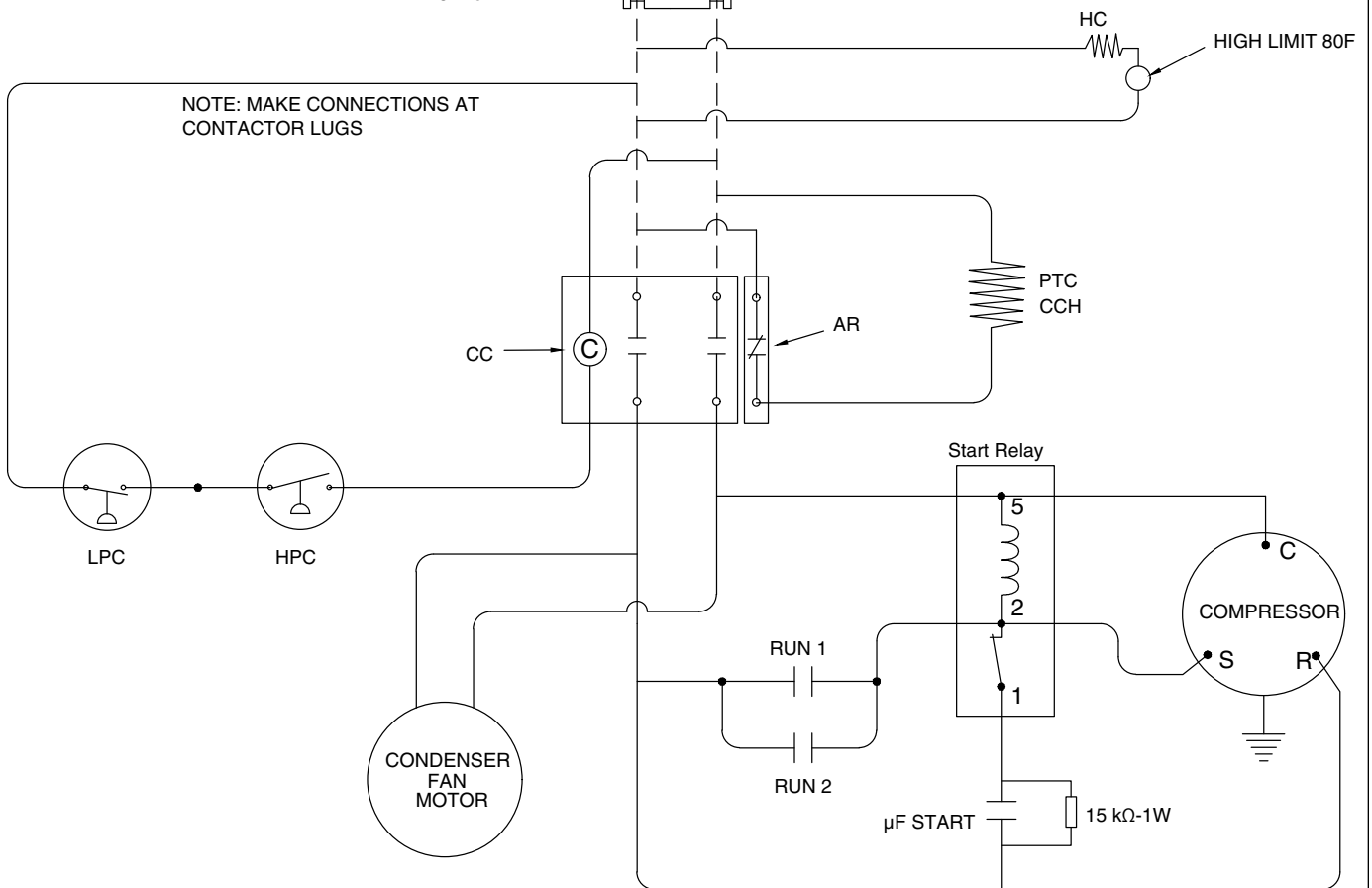

3-phase condensing unit wiring diagram

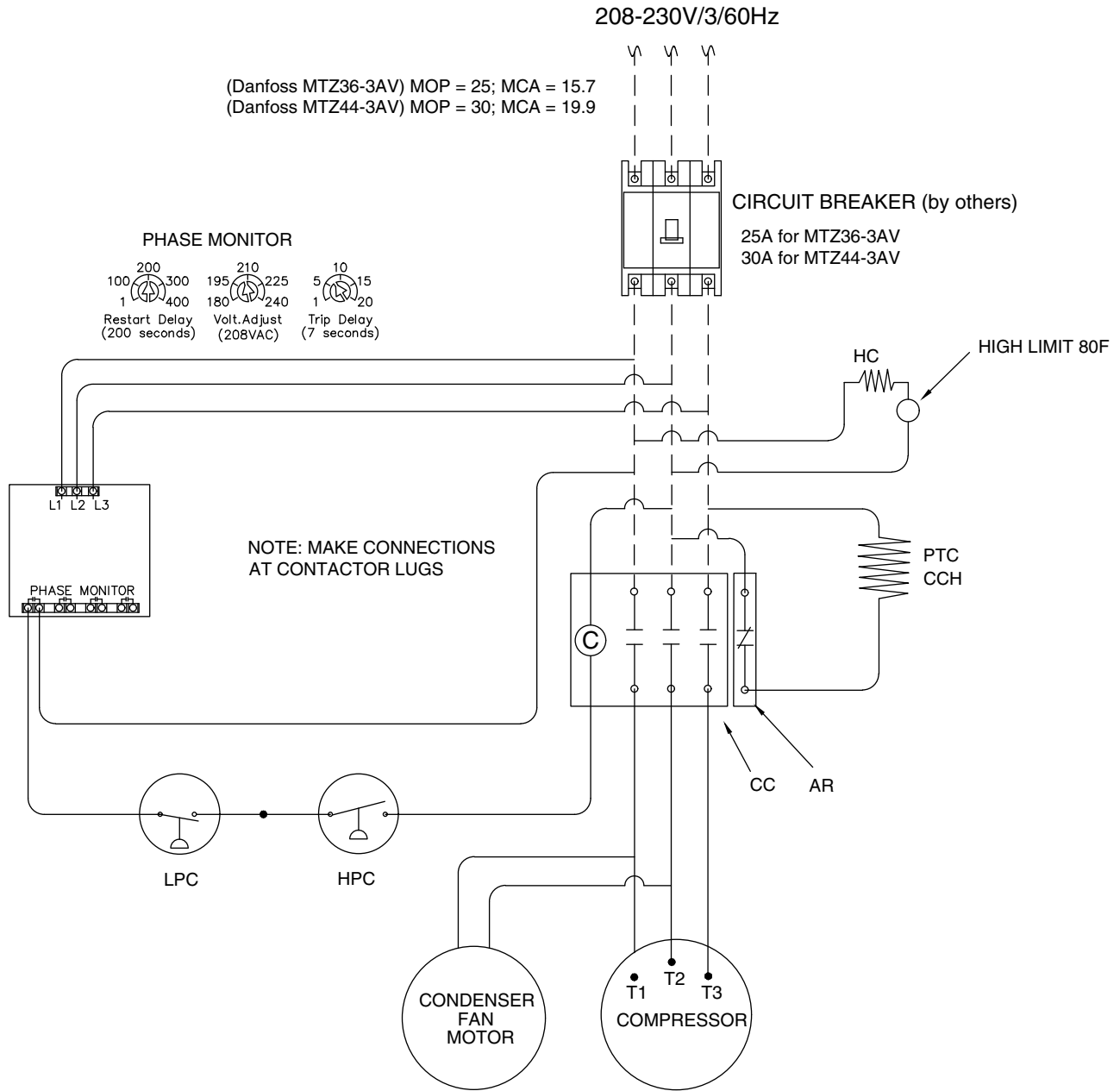

Mechanical System

Evaporator disassembly

1. Press CLEAN button to purge evaporator. Turn power OFF when LO WATER lights.
2. Unscrew and disconnect transport tube from louvered docking assembly.

Fig. 10

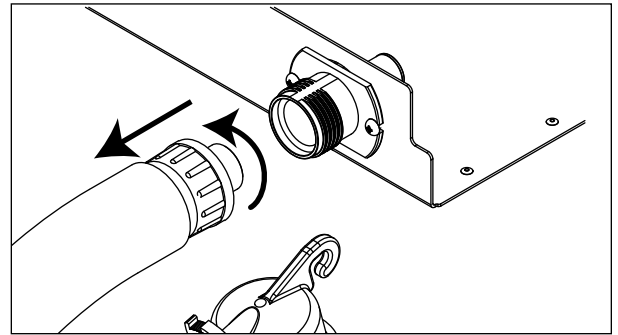

3. Remove gearbox insulation..

Fig. 11

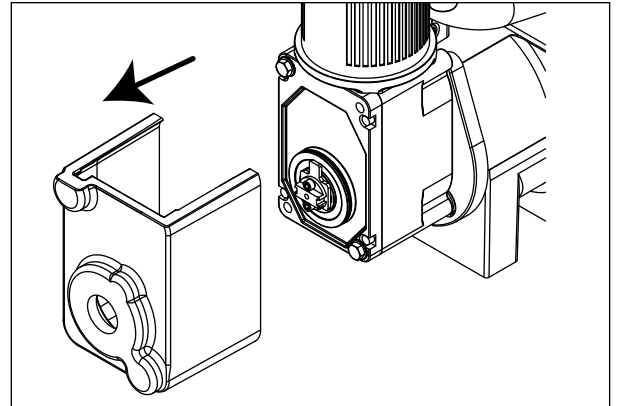

4. Disconnect gear motor wires.

Fig. 12

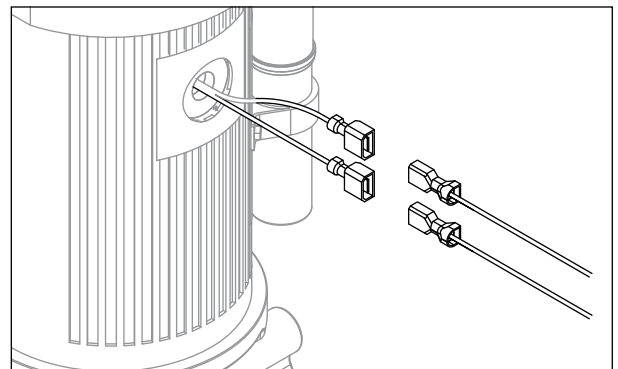

5. Remove screws (with 3/16" allen wrench) and auger retaining fork:

Fig. 13

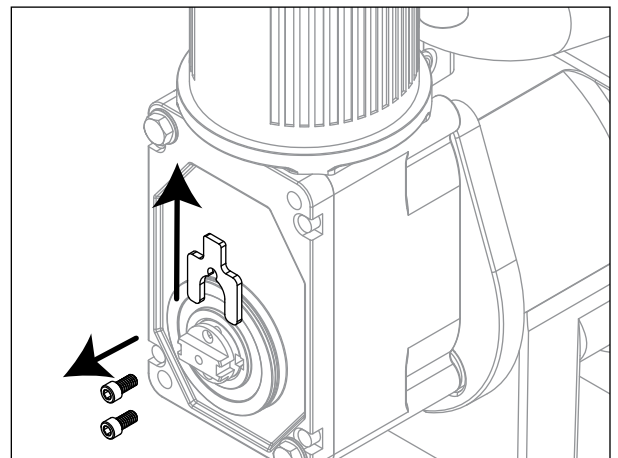

6. Remove gear motor bolts (9/16" wrench).
7. Remove gear motor and wipe auger shaft clean.

Fig. 14

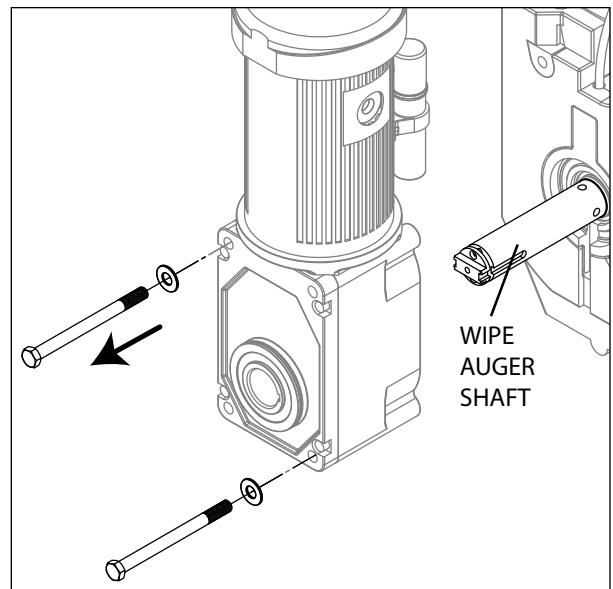

8. Remove main housing insulation and shuttle insulation:

Fig. 15

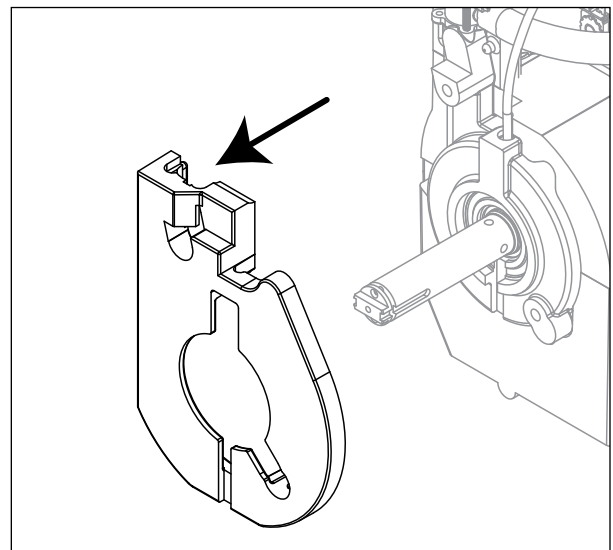

9. Remove front feed water tube from push-in fitting, shuttle drain tube, and shuttle switch.

Fig. 16

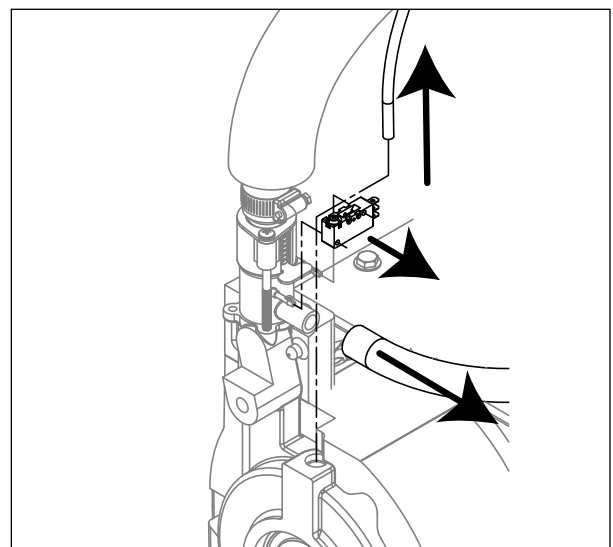

10. Remove 3 screws (with 3/16" allen wrench) then remove auger and main housing together.

Note: Auger is sharp - wear protective gloves.:

Fig. 17

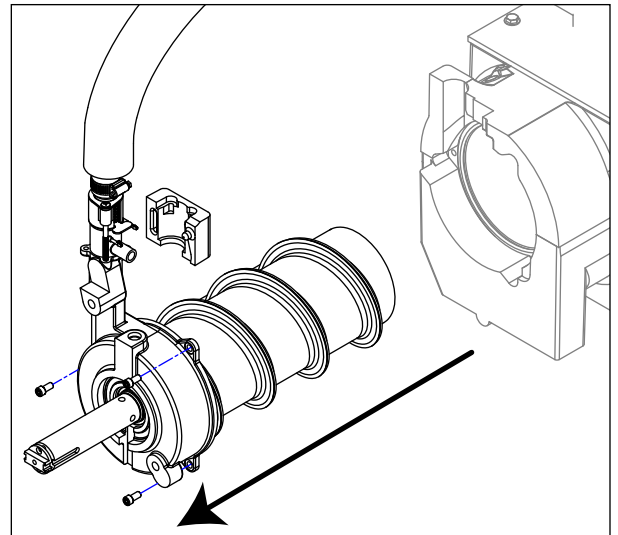

11. Rotate auger to align opening in auger flange with stream divider.

12. Pull out auger.:

Fig. 18

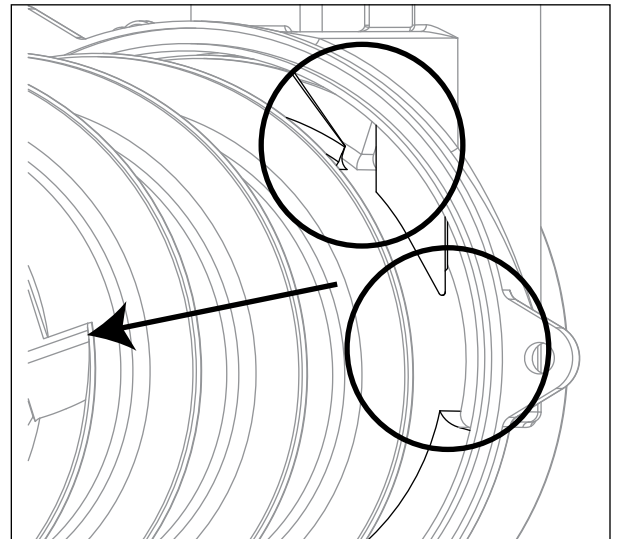

13. Remove and discard the ceramic mating ring and shaft seal.

Fig. 19

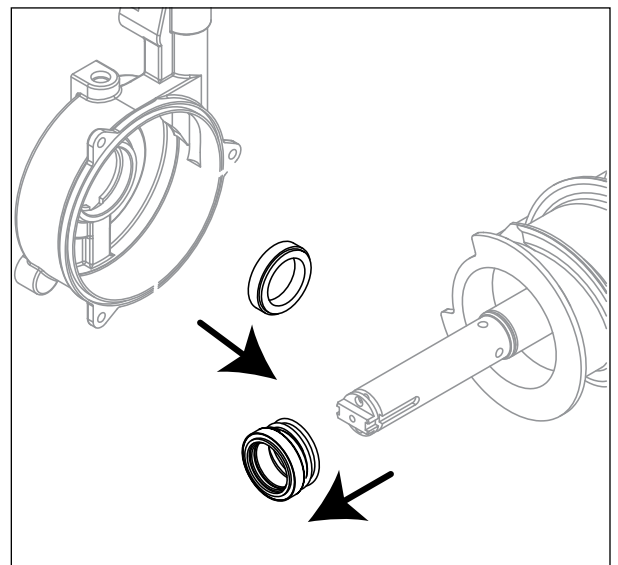

Evaporator reassembly

14. Install ceramic mating ring and shaft seal.

Caution: Do not touch the sealed surface of either part. Oil from bare skin will cause premature seal failure.

15. Use liquid hand soap on the rubber part of the ceramic seal when installing in main housing. Use supplied cardboard disc to press into recess.
16. Apply liquid hand soap to raised area of auger shaft and interior rubber portion of shaft seal before installing seal.
17. Clean O ring groove. Lubricate O ring with petrol-gel and reinstall.

Fig. 20

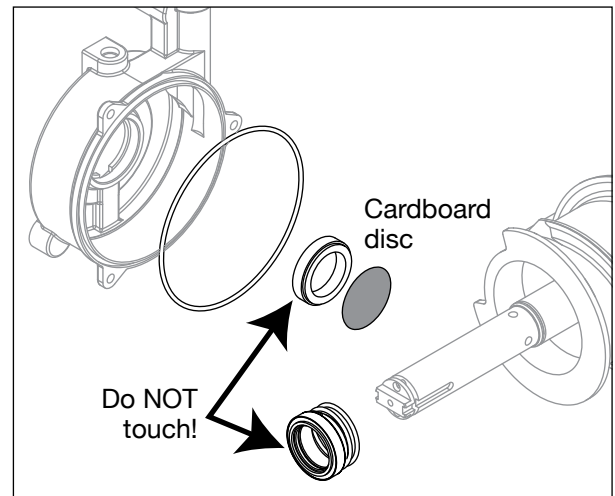

18. Carefully install auger.
19. Rotate auger to position shown to clear main housing stream divider.

Fig. 21

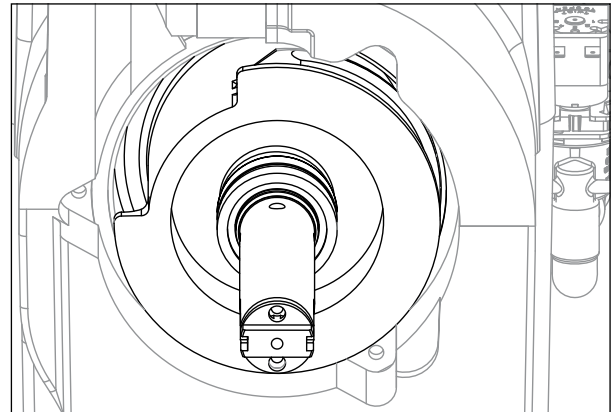

20. Install rear shuttle insulation (Fig. 22.1) and slide main housing (Fig. 22.2) onto auger.
21. When installing new water seal, use screwdriver to compress the spring (Fig. 22.3), which allows for easier installation of the three screws.

Fig. 22

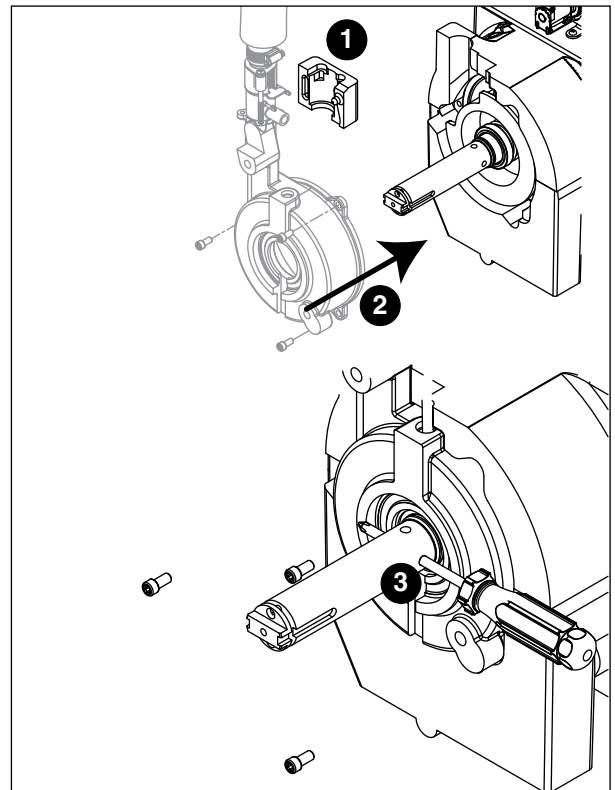

22. Install shuttle switch.

- Align holes with pins (Fig. 23.1) and depress switch button (Fig. 23.2) to clear shuttle tab.

Fig. 23

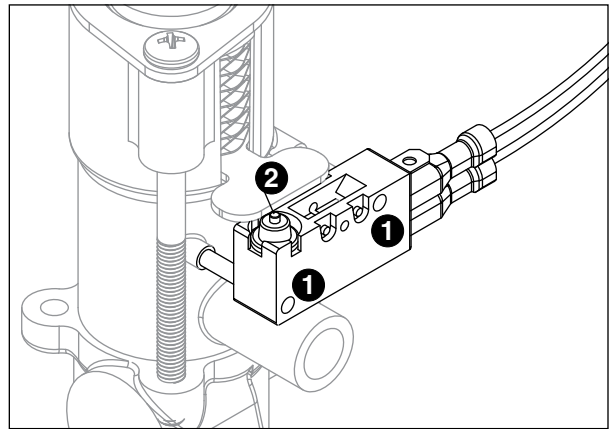

23. Install shuttle drain tube and front feed water tube (Fig. 24).

Fig. 24

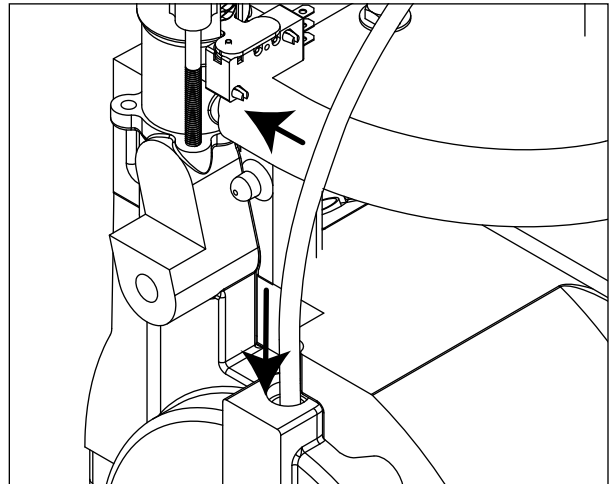

24. Install main housing insulation and shuttle insulation:

25. Apply a coat of petro gel to auger shaft.

Fig. 25

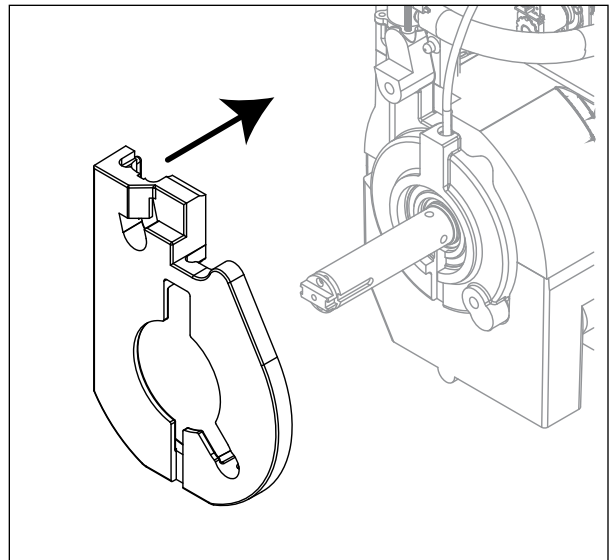

26. Slide gear motor onto auger and install gear motor bolts (9/16" wrench).

Fig. 26

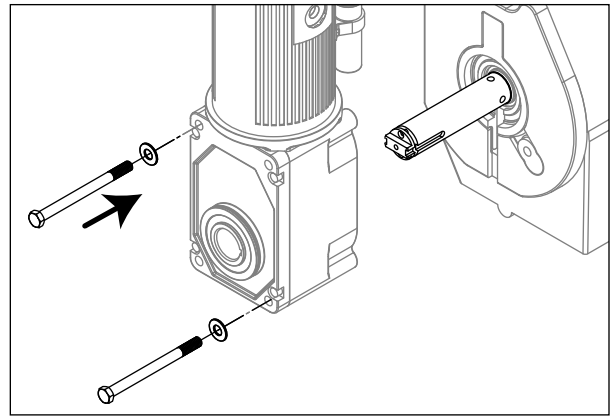

27. Connect gear motor wires.

Fig. 27

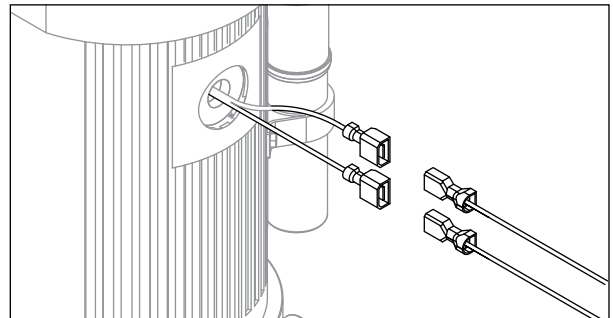

28. Pry auger forward and rotate auger using 1/2" wrench to align keyways.

Fig. 28

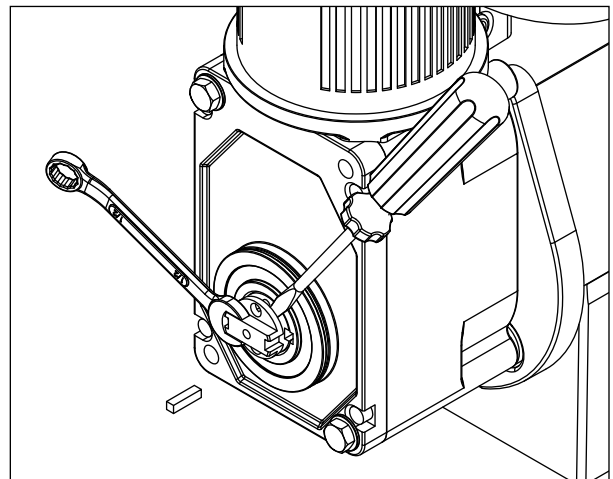

29. Insert key fully.

Fig. 29

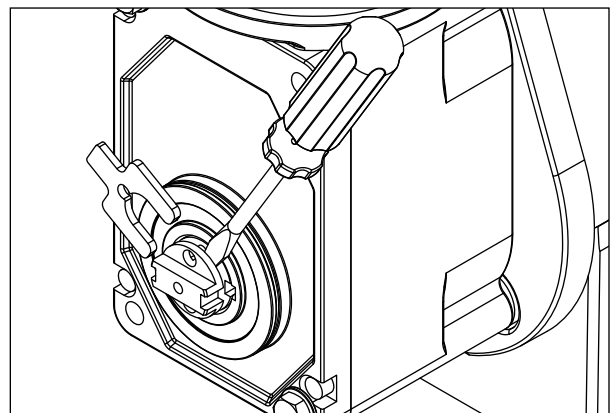

30. Pry shaft forward to install retainer fork.

- 31. Rotate retainer fork to align screw holes.
- 32. Install screws to secure retainer fork.

Fig. 30

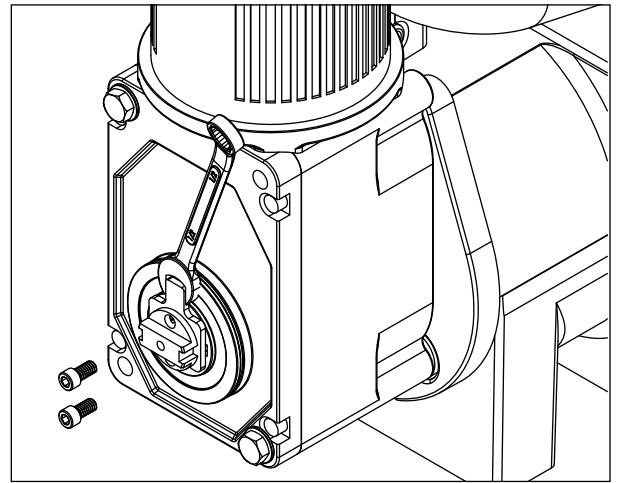

- 33. Install gearbox insulation.

Fig. 31

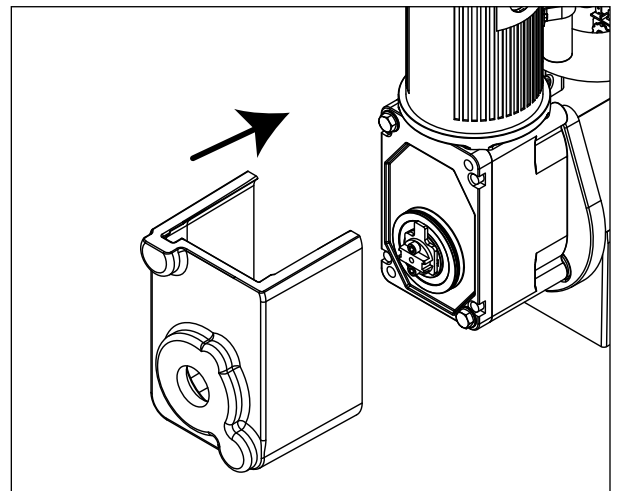

- 34. Connect transport tube to louvered docking assembly.

Fig. 32

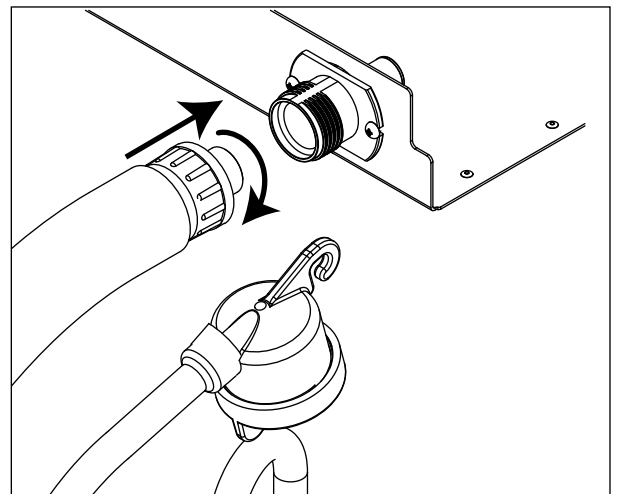

Reservoir/rear bushing disassembly **Fig. 33**

1. Press CLEAN button to purge evaporator. Turn power OFF when LO WATER lights.

Note: *In many applications, removing the garmotor, main housing, and auger will allow for the ice machine to be pulled out further for better access to rear components.*

2. Slide ice machine forward to gain access.
3. Use Fig. 32 as disassembly guide.

Note: *Use petrogel when installing/reinstalling o-rings.*

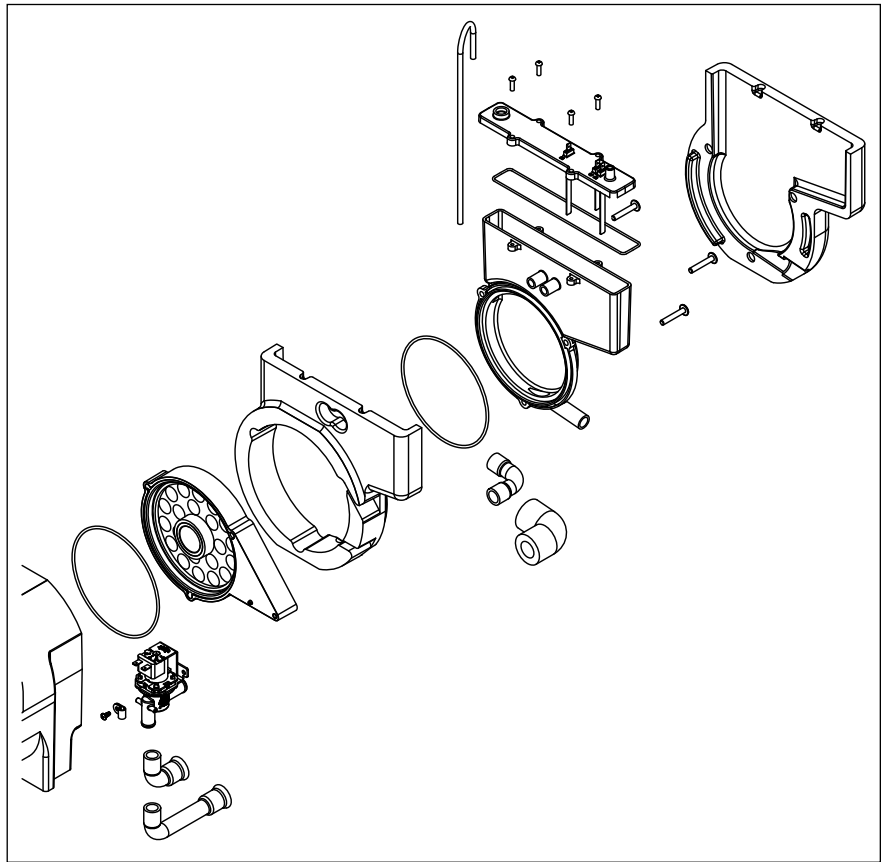
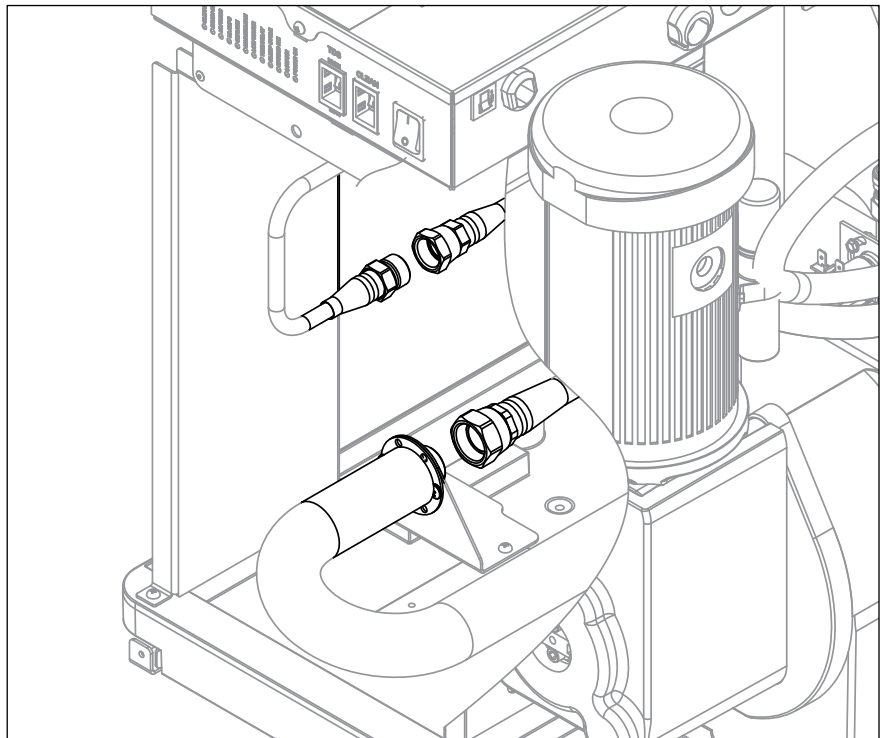

Fig. 34

Attention:

Access to the reservoir and rear bushing is accomplished by disconnecting the suction and liquid line quick disconnects. These disconnects are self-sealing and do not require unit to be pumped down. When disconnected, unit can be pulled forward for access.



Refrigeration system

Condenser unit operation

The condensing unit is weatherproof and equipped to operate in ambient temperatures from -20 F to 120 F (-29 C to 48.9 C). The condensing unit is controlled by a low and high pressure switches, which works in concert with a refrigerant solenoid valve on the evaporator module. On start-up, the refrigerant solenoid valve opens and suction pressure rises above the "on" set point of the high pressure switch. The compressor and fan turn on and the refrigeration system operates. Upon shut down, the refrigerant solenoid closes. The compressor will pump down the ice machine evaporator and suction line until the low "off" set point of the low pressure switch is reached, at which point the compressor and fan will turn off.

Low ambient operation: Reliable operation at low outdoor ambient temperature is achieved with a pumpdown cycle, a crankcase heater and a head pressure control valve. When the outdoor ambient falls, the condensing pressure falls. This causes the discharge pressure to fall as well. When the discharge pressure falls below the dome pressure, the valve modulates open to the discharge port which allows discharge gas to bypass the condenser. Mixing the discharge gas with the liquid creates a high pressure at the condenser outlet, reducing the flow and causing liquid to back up in the condenser. Flooding the condenser reduces the area available for condensing. This reduction in effective condenser surface area results in a rise in condensing pressure. During summer conditions, the discharge pressure is high, thus closing the discharge port of the valve. Hence, there is full liquid flow from the condenser to the receiver.

A check valve is installed in the liquid line between the liquid receiver and the condenser to prevent liquid migration from the receiver to the condenser during the off cycle. A second check valve is installed in the discharge outlet of the motor compressor to prevent any oil from migrating onto the compressor head during an off cycle. A low pressure control will start the condensing unit anytime the low side pressure rises above the C/I setting of the control. The system contains a crankcase heater which is energized via the auxilliary contactor of the compressor during any off cycle. It is de-energized whenever the compressor is energized. This keeps the oil temperature in the compressor sump warmer than any other wetted surface to prevent liquid migration from settling into the compressor sump to prevent flooded compressor starts in extreme outdoor temperatures. The liquid receiver also contains a heater which is controlled by a thermostat and is de-energized above 80°F. This is to maintain sufficient refrigerant pressure at extreme outdoor temperatures to activate the pressure switch.

1810 - Operating Pressure (Discharge PSIG/Suction PSIG)

		Water Temperature F/C				
		F	50	60	70	80
Evap Potable Water Temperature F/C	C	10	16	21	27	32
	60	182/27	182/27	182/27	182/27	183/27
	16					
	70	188/28	188/28	188/28	188/27	188/27
	21					
	80	218/30	218/30	218/30	218/30	219/30
	27					
	90	249/32	249/32	249/32	249/32	249/32
	32					
	100	282/34	282/34	282/34	282/34	282/34
38						

2110 - Operating Pressure (Discharge PSIG/Suction PSIG)

		Water Temperature F/C				
		F	50	60	70	80
Evap Potable Water Temperature F/C	C	10	16	21	27	32
	60	189/28	188/28	189/28	188/27	186/27
	16					
	70	192/28	191/28	192/28	192/28	191/28
	21					
	80	220/29	219/30	219/30	219/31	220/31
	27					
	90	252/33	252/33	252/33	252/33	252/33
	32					
	100	285/35	285/35	284/35	284/35	285/34
38						

Refrigeration system diagram

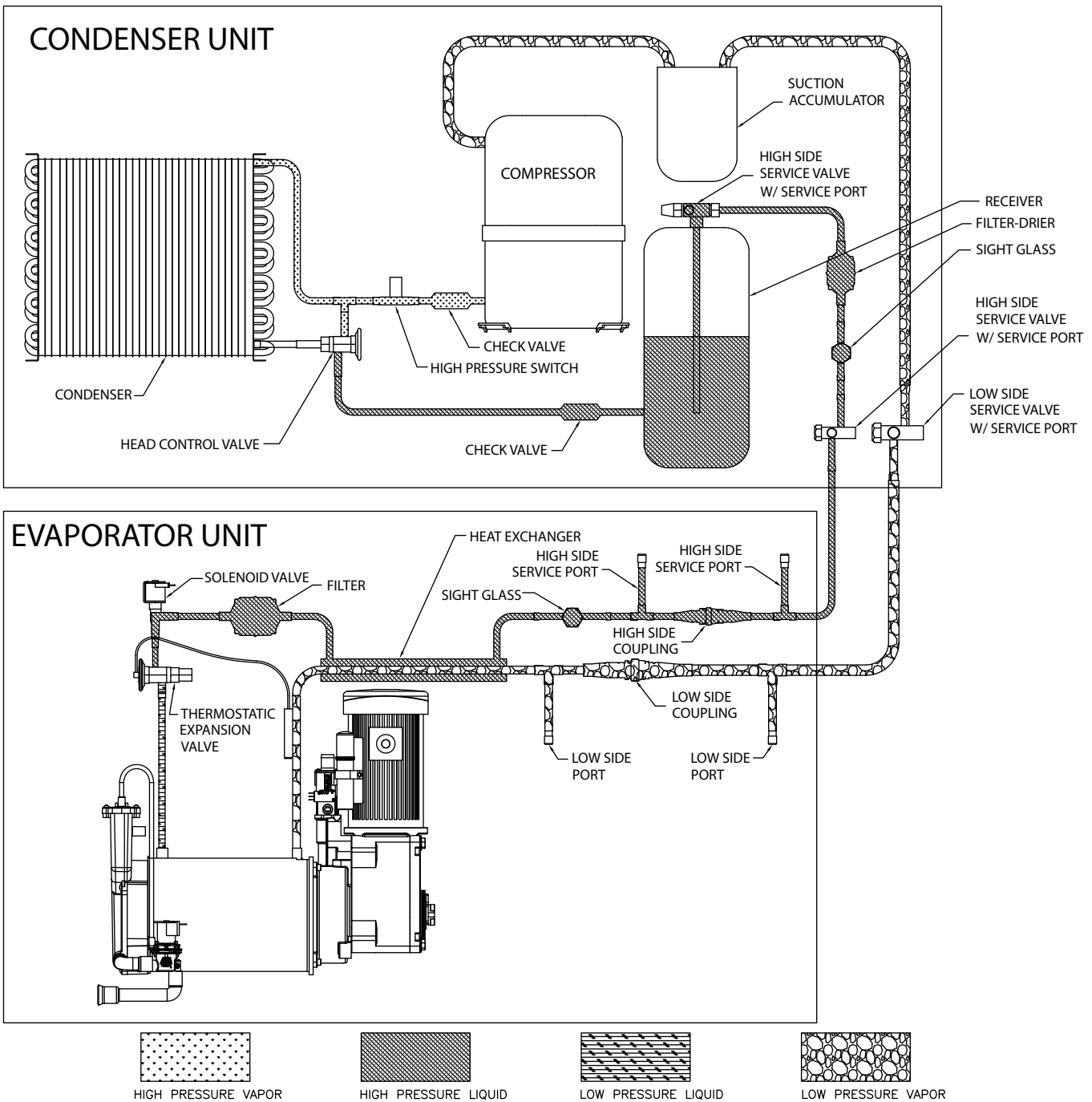

Refrigeration charge

All service on refrigeration systems must be performed in accordance with all federal, state and local laws. It is the responsibility of the technician to ensure that these requirements are met. Recharging ice machine to other than factory specifications will void the warranty.

Attention: Unit must be charged by weight, not by clear sight glass.

R404A ice machine charge specifications for 1810/2110 models with line runs of 0 to 75 ft. (0 m to 22.8 m)

Total charge	14.5 lbs (6.57 kg)
Condensing unit holding charge	0.5 lbs (0.23 kg)
Charge at installation	14 lbs (6.35 kg)

Note: Condensing unit shipped with 0.5 lb of R404A charge.

Refrigerant replacement requirements

1. Non-contaminated refrigerant removed from any Follett refrigeration system can be recycled and returned to the same system after completing repairs. Recycled refrigerant must be stored in a clean, approved storage container. If additional refrigerant is required, virgin or reclaimed refrigerant that meets ARI standard 700-88 must be used.
2. In the event of system contamination (for example, a compressor burn out, refrigerant leak, presence of non-condensibles or moisture), the system must be repaired, evacuated and recharged using virgin or reclaimed refrigerant that meets ARI standard 700-88.
3. Follett LLC does not approve of recovered refrigerants. Improper refrigeration servicing procedures will void the factory warranty.

Evacuation

Evacuate the system to a level of 500 microns. When the 500 micron level is reached, close all valves. Allow the system to sit for approximately 20 minutes. During this period the system pressure should not rise. If the system pressure rises and stabilizes there is moisture in the system and further evacuation is needed. If the pressure continues to rise check the system for leaks.

Ambients	Minimum	Maximum
Air temperature ¹	50 F/10 C	100 F/37.8 C
Water temperature ²	45 F/7 C	90 F/32.2 C

¹Ambient air temperature is measured at the air-cooled condenser coil inlet.

²Ambient water temperature is measured in the ice machine water reservoir.

Ice capacity test

Ice machine production capacity can only be determined by weighing ice produced in a specific time period.

1. Replace all panels on ice machine.
2. Run ice machine for at least 15 minutes.
3. Weigh and record weight of container used to catch ice.
4. Catch ice for 15 or 20 minutes.
5. Weigh harvested ice and record total weight.
6. Subtract weight of container from total weight.
7. Convert fractions of pounds to decimal equivalents (ex. 6 lbs 8oz = 6.5 lbs).
8. Calculate production using following formula:

$$\frac{1440 \text{ min.} \times \text{wt. of ice produced}}{\text{Total test time in minutes}} = \text{Production capacity/24 hr.}$$

9. Calculated amount per 24 hours should be checked against rated capacity for same ambient and water temperatures in Ice Production Tables.

Troubleshooting

Please see "Service" section for a description of each function.

Ice machine disposition	Possible causes	Corrective action
Legend: ● ON ○ OFF ◐ ON or OFF ✖ FLASHING		
1. Ice machine is in running condition but not making ice. CLEANER FULL ○ DRAIN CLOG ○ HI PRESS ○ HI AMPS ○ SERVICE ○ MAINT/CLEAN ○ LOW WATER ○ TIME DELAY ○ NOT USED ○ MAKING ICE ● LOW BIN ● POWER ON ✖	1. No output from PC board. 2. Defective start relay. 3. Defective start capacitor. 4. Defective run capacitor. 5. Defective main contactor. 6. Defective compressor.	1. Replace PC board. 2. Replace start relay. 3. Replace start capacitor. 4. Replace run capacitor. 5. Replace main contactor. 6. Replace compressor.
2. Machine in TIME DELAY without full bin. CLEANER FULL ○ DRAIN CLOG ○ HI PRESS ○ HI AMPS ○ SERVICE ○ MAINT/CLEAN ○ LOW WATER ○ TIME DELAY ● NOT USED ○ MAKING ICE ○ LOW BIN ● POWER ON ✖	1. Ice jamming due to improperly installed transport tube causing a false shuttle. 2. Shuttle stuck in up position. 3. Damaged or improperly installed thermostat (open). 4. Transport tube backed-out of coupling.	1. Correct transport tube routing. 2. Repair or replace shuttle mechanism. 3. Replace or reposition thermostat. 4. Correct coupling installation.
3. Ice machine is not making ice. HI AMPS. CLEANER FULL ○ DRAIN CLOG ○ HI PRESS ○ HI AMPS ● SERVICE ○ MAINT/CLEAN ○ LOW WATER ○ TIME DELAY ○ NOT USED ○ MAKING ICE ○ LOW BIN ● POWER ON ✖	1. Poor water quality causing ice to jam auger. 2. Damaged shuttle mechanism. 3. Intermittent drive output from PC board. Evaporator will freeze causing a HI AMPS error. 4. Gearmotor is unplugged.	1. Clean ice machine. Increase flushing frequency. Position TDS switch to High TDS setting. 2. Replace or repair shuttle mechanism. 3. Replace PC board. 4. Plug in gearmotor.
4. Ice machine is not making ice. SERVICE. CLEANER FULL ○ DRAIN CLOG ○ HI PRESS ○ HI AMPS ○ SERVICE ● MAINT/CLEAN ○ LOW WATER ○ TIME DELAY ○ NOT USED ○ MAKING ICE ○ LOW BIN ● POWER ON ✖	1. Internal water leak touching chassis sensor.	1. Identify and repair leak. Clean/dry chassis and sensors and restart machine.
5. Drain clog. CLEANER FULL ○ DRAIN CLOG ● HI PRESS ○ HI AMPS ○ SERVICE ○ MAINT/CLEAN ○ LOW WATER ○ TIME DELAY ○ NOT USED ○ MAKING ICE ○ LOW BIN ● POWER ON ✖	1. Improper flow in drain system.	1. Correct/clean drain system.

Ice machine disposition	Possible causes	Corrective action
Legend: ● ON ○ OFF ◐ ON or OFF ✖ FLASHING		
<p>6. Ice machine is making ice. Excessive water in bin or coming into bin from transport tube.</p> <p> <input type="radio"/> CLEANER FULL <input type="radio"/> DRAIN CLOG <input type="radio"/> HI PRESS <input type="radio"/> HI AMPS <input type="radio"/> SERVICE <input type="radio"/> MAINT/CLEAN <input type="radio"/> LOW WATER <input type="radio"/> TIME DELAY <input type="radio"/> NOT USED <input type="radio"/> MAKING ICE <input checked="" type="radio"/> LOW BIN <input checked="" type="radio"/> POWER ON </p>	<ol style="list-style-type: none"> 1. Failed water sensors. Processor assumes there is no water when there is water. 2. Blocked reservoir vent. 3. Defective water feed solenoid valve. Stuck in open position. 	<ol style="list-style-type: none"> 1. Clean or replace water probe assembly. Check wiring connections. 2. Clean or replace vent tubes. 3. Replace water feed solenoid valve.
<p>7. Ice machine is not making ice. Lo water.</p> <p> <input type="radio"/> CLEANER FULL <input type="radio"/> DRAIN CLOG <input type="radio"/> HI PRESS <input type="radio"/> HI AMPS <input type="radio"/> SERVICE <input type="radio"/> MAINT/CLEAN <input checked="" type="radio"/> LOW WATER <input checked="" type="radio"/> TIME DELAY <input type="radio"/> NOT USED <input type="radio"/> MAKING ICE <input checked="" type="radio"/> LOW BIN <input checked="" type="radio"/> POWER ON </p>	<ol style="list-style-type: none"> 1. Water supply is insufficient. 2. Low water pressure. 3. Defective water feed solenoid valve. Stuck in closed position. 4. No water feed output from PC board. 5. Plugged screen on inlet side of fill solenoid. 6. Plugged check valve. 	<ol style="list-style-type: none"> 1. Restore water supply and check water filters. If evaporator was completely empty the reset button may have to be pressed to restart the ice machine. 2. Ice machine will eventually start when water reaches normal lo level. 3. Replace water feed solenoid valve. 4. Replace PC board. 5. Remove and clean screen. 6. Remove and clean.
<p>8. Blinking Lo water, power, time delay.</p> <p> <input type="radio"/> CLEANER FULL <input type="radio"/> DRAIN CLOG <input type="radio"/> HI PRESS <input type="radio"/> HI AMPS <input type="radio"/> SERVICE <input type="radio"/> MAINT/CLEAN <input checked="" type="radio"/> LOW WATER <input checked="" type="radio"/> TIME DELAY <input type="radio"/> NOT USED <input type="radio"/> MAKING ICE <input type="radio"/> LOW BIN <input checked="" type="radio"/> POWER ON </p>	<p>Machine did not see water consumption while trying to make ice.</p> <ol style="list-style-type: none"> 1. Lack of refrigeration/low refrigerant charge/leak. 2. Debris shorting reservoir probes. 	<ol style="list-style-type: none"> 1. Verify refrigerant pressures, compressor running, sight glass clear. 2. Clean probes and reservoir of debris.
<p>9. Blinking Lo water, power, time delay.</p> <p> <input type="radio"/> CLEANER FULL <input type="radio"/> DRAIN CLOG <input type="radio"/> HI PRESS <input type="radio"/> HI AMPS <input type="radio"/> SERVICE <input type="radio"/> MAINT/CLEAN <input checked="" type="radio"/> LOW WATER <input checked="" type="radio"/> TIME DELAY <input type="radio"/> NOT USED <input type="radio"/> MAKING ICE <input type="radio"/> LOW BIN <input checked="" type="radio"/> POWER ON </p>	<p>Machine did not see water consumption while trying to make ice.</p> <ol style="list-style-type: none"> 1. Lack of refrigeration/low refrigerant charge/leak. 2. Debris shorting reservoir probes. 	<ol style="list-style-type: none"> 1. Verify refrigerant pressures, compressor running, sight glass clear. 2. Clean probes and reservoir of debris..



ATTENTION!

To prevent circuit breaker overload, wait 5 minutes before restarting this unit. This allows the compressor to equalize and the evaporator to thaw.

Replacement parts

Evaporator assembly

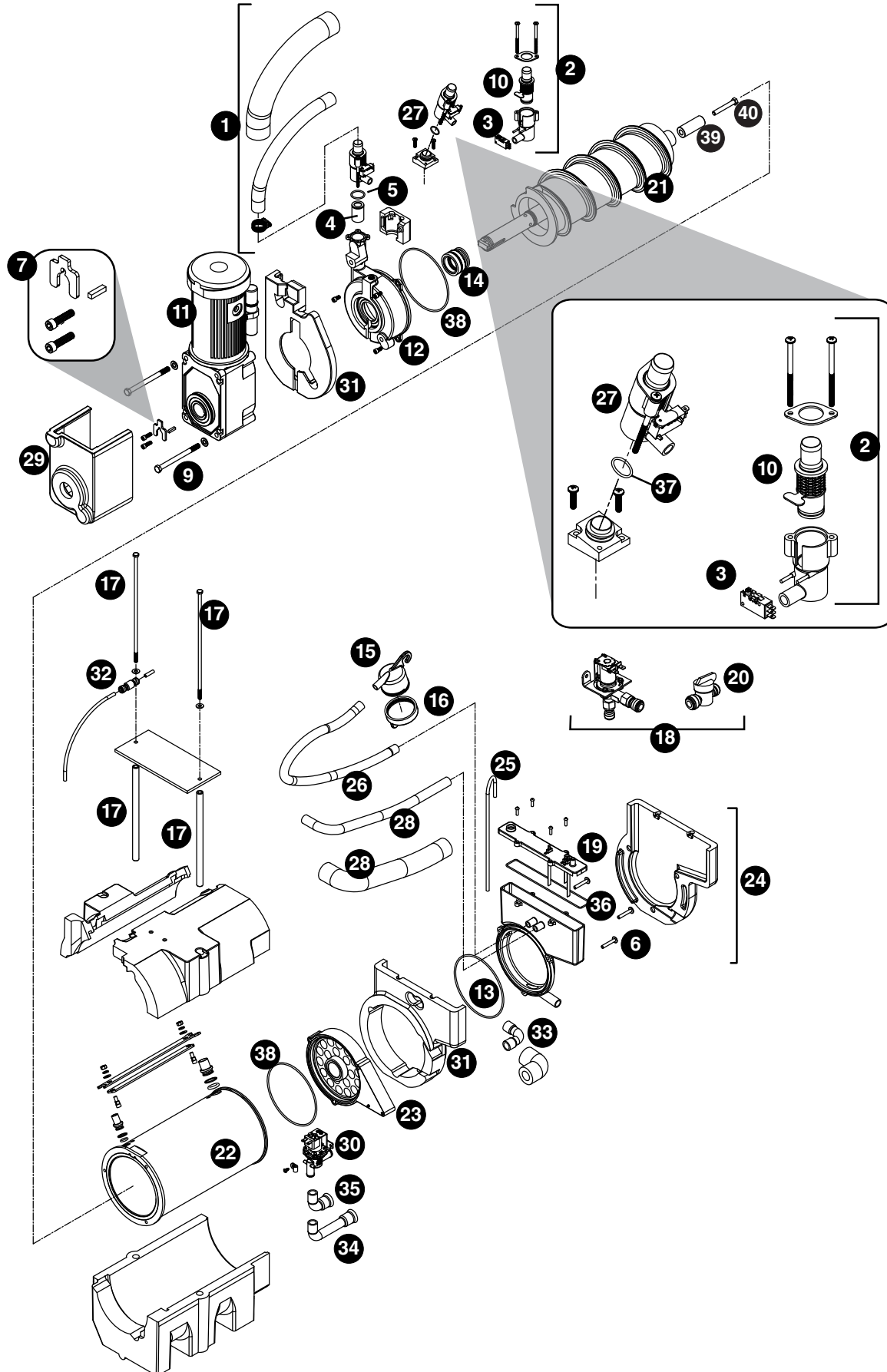

Reference #	Description	Part #
1	Tube, ice transport, insulated	01118181
2	Shuttle assembly	01118132
2	Shuttle assembly, IMDV	01118140
3	Switch, shuttle	01006261
4	Compression nozzle	01278654
5	O-ring, shuttle	01164920
6	Screw, reservoir (3 required)	206395
7	Auger hardware (includes screws, key, retainer)	01118611
8	Key	01164938
9	Bolt, gearmotor mounting (2) (remote condensing units), includes washers	01118629
10	Cartridge assembly, shuttle spring	01118033
10	Cartridge, shuttle spring, IMDV	01118041
11	Gearmotor, 120 V (includes capacitor)	01164946
12	Main housing	01164961
13	O ring, square profile, reservoir to bushing housing	01164979
14	Seal, auger shaft	01302249
15	Cup, sanitizer	01164995
16	Cap, sanitizer	01118637
Not shown	Tubing, water, 3/8" OD	502719
Not shown	Tubing, water, 1/4" OD	502079
17	Retainer kit, evaporator	01118652
18	Solenoid, water feed, 120 V	01441526
19	Reservoir lid and sensors (includes screws and o-ring)	01165026
20	Valve, shut-off, water	502921
21	Auger, 1810 (includes seal, key, journal, bolt and auger hardware)	01165034 (1810 only)
21	Auger, 2110 (includes seal, key, journal, bolt and auger hardware)	01165075 (2110 only)
22	Evaporator, 1810	01165083 (1810 only)
22	Evaporator, 2110	01165174 (2110 only)
23	Rear bushing housing and bushing (includes (1) o-ring)	01165182
24	Reservoir assembly, water (includes lid)	01165232
25	Tube, vent (20" required)	502079
26	Tube, sanitizer	01118660
27	Kit, MicroChewblet	01161843
28	Tube, shuttle drain, insulated	01165216
29	Insulation, gearbox, 120 V	01165240
30	Solenoid, purge, 120 V	01337286
31	Insulation kit, evaporator/reservoir, 1810	01165737 (1810 only)
31	Insulation kit, evaporator/reservoir, 2110	01165505 (2110 only)
32	Check valve	01122381
33	Tube, drain, reservoir, insulated	01118124
34	Tube, drain, 1810	01165513 (1810 only)
35	Tube, drain, 2110	01165521 (2110 only)
36	O-ring, reservoir lid	01165539
Not shown	Kit, scale (includes reservoir, purge solenoid, drain tubes and fitting)	01165547
37	O-ring, Micro Chewblet	01161850
Not shown	Drain kit (includes 2 ft. x 1" OD silicone tubing, 3/4" x 1" slip, 3/4" barb 3/4" FPT (2), 3/4" barb x 3/4" FPT elbow)	01210350
38	O ring, round profile	01435007
39	Journal, threaded	01477538
40	Bolt, journal	01478759

Low-side assembly

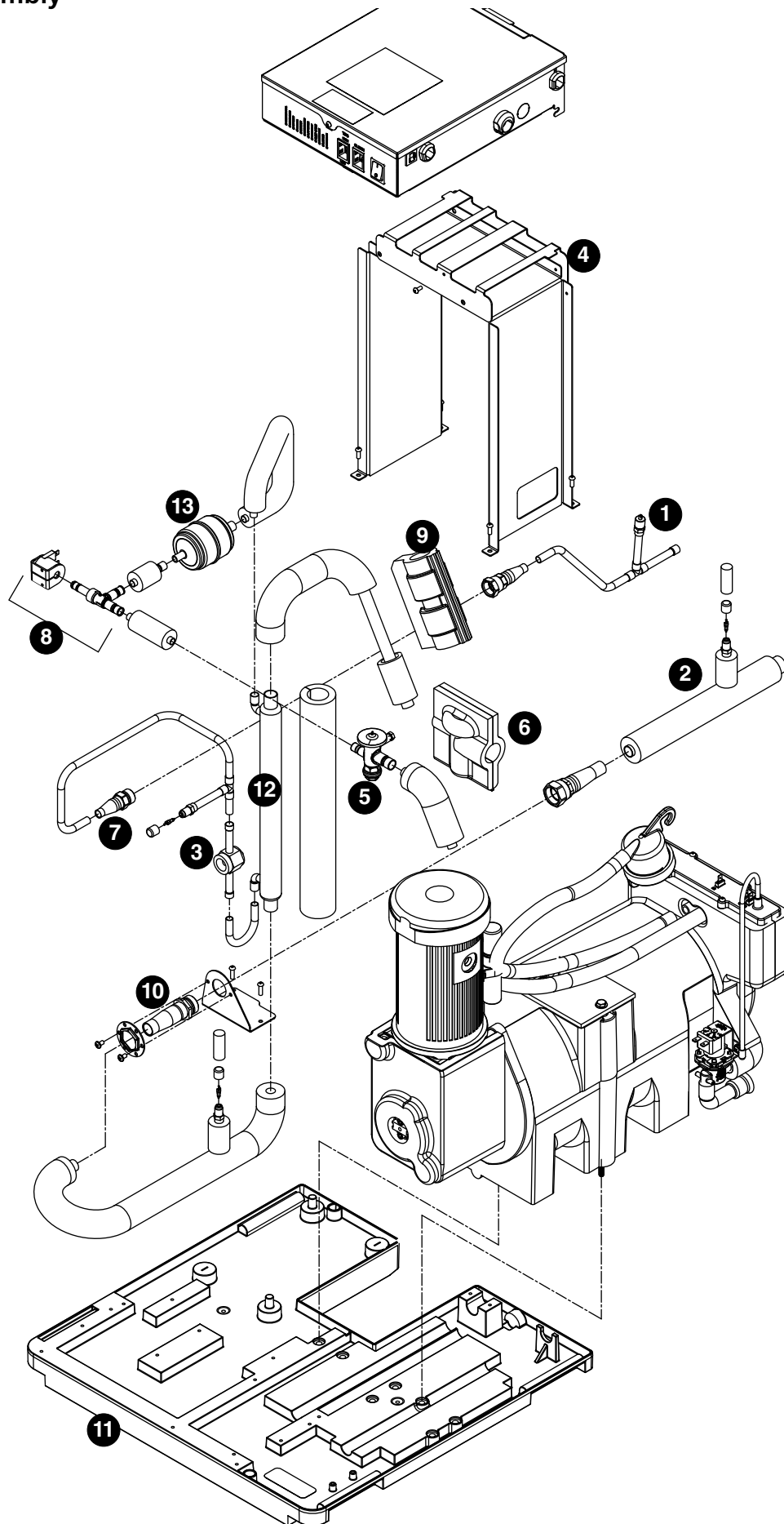

Reference #	Description	Part #
1	Tubing, liquid line, quick connect	01165554
2	Tubing, suction line (includes insulation), quick connect	01165562
3	Sight glass	01165570
4	Electrical box support	01121292
5	Valve, expansion, thermal (includes TXV insulation)	01165596
6	Insulation, TXV (body)	01165604
7	Coupling, quick connect, male, liquid line	01165620
8	Kit, liquid line solenoid (Includes filter drier)	01191493
9	Insulation, bulb, TXV	502830
10	Coupling, quick connect, male, suction line	01165638
11	Base, split system	01333772
12	Heat Exchanger	01121409
13	Filter drier	01153683

Electrical box

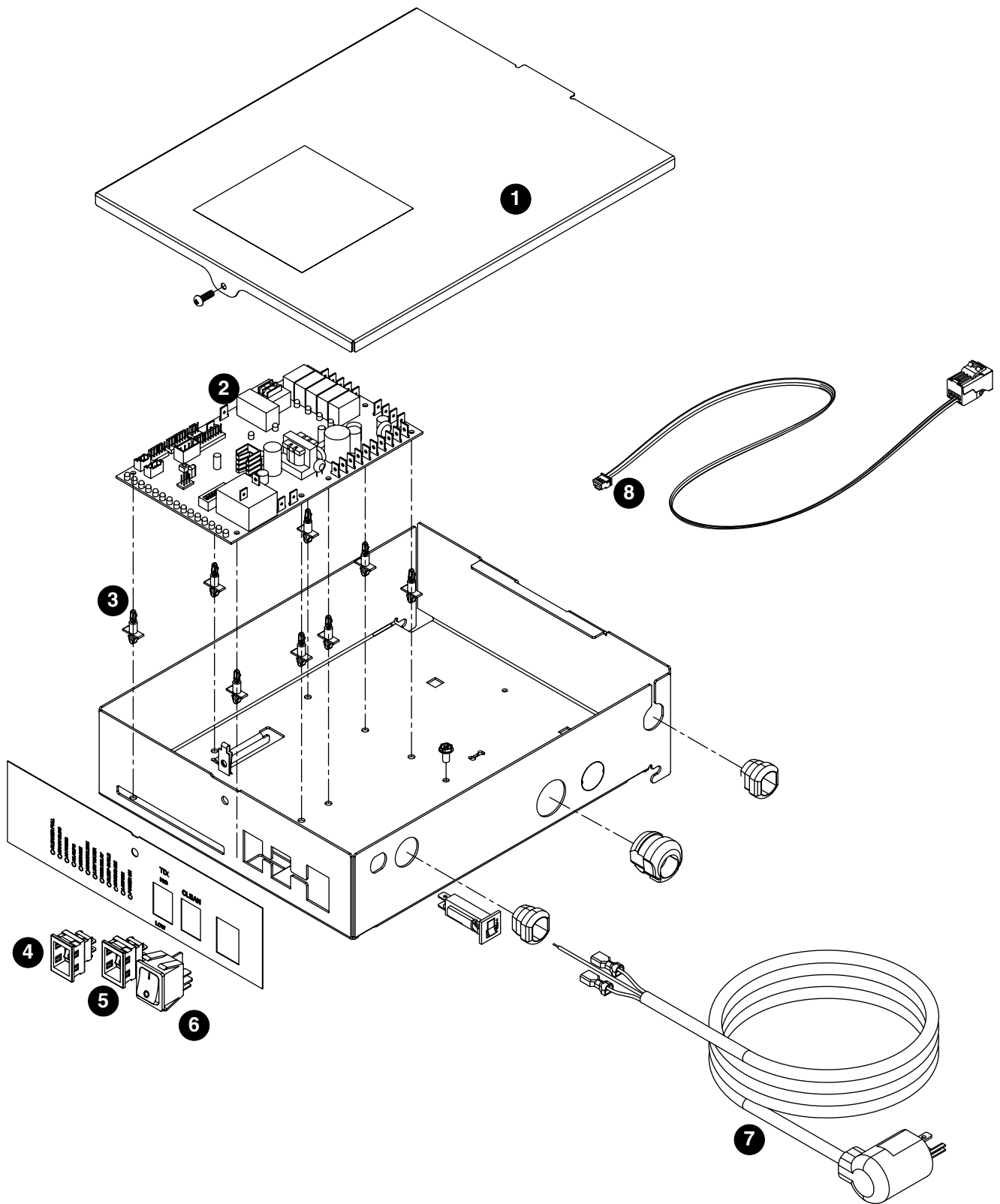

Reference #	Description	Part #
1	Cover, electrical box, air/water-cooled	01165729
2	Board, control, 120 V (includes stand-offs)	01165679
3	Stand-offs (set of 8)	00130906
4	Switch, TDS	01165695
5	Switch, evaporator clean	01165703
6	Switch, ice machine power	01165711
7	Cord, power, 120 V	01111491
8	Cable, IMDV	01116177
Not shown	Sleep Cycle Kit (top mount applications)	01528462

Integration kit – top-mount and RIDE remote ice delivery

Top mount configuration

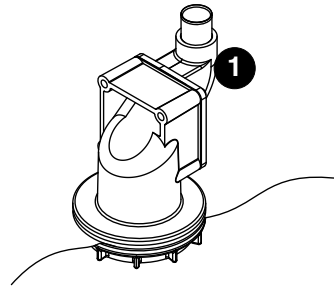
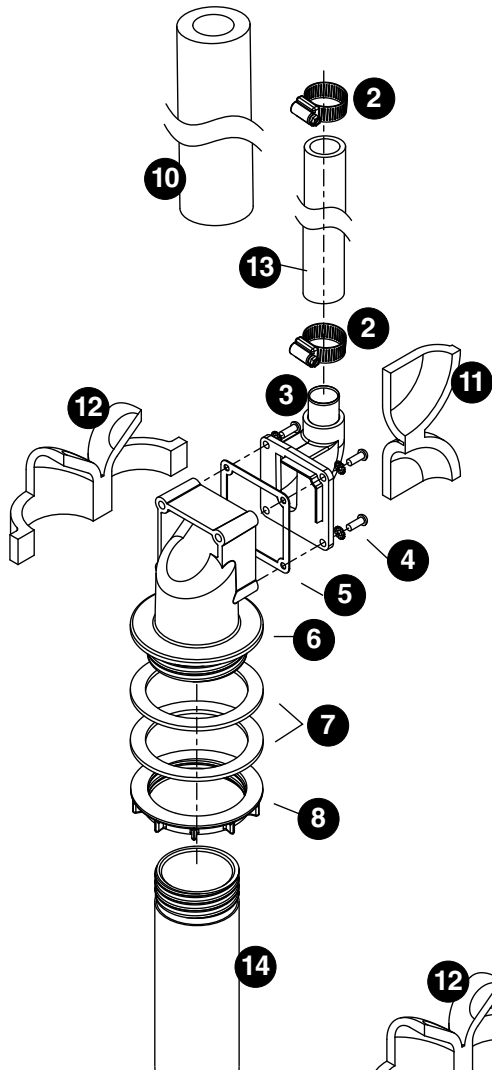

RIDE model configuration

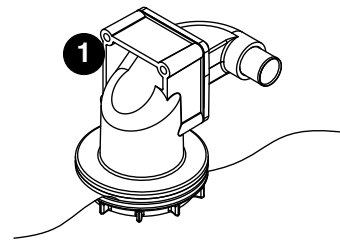
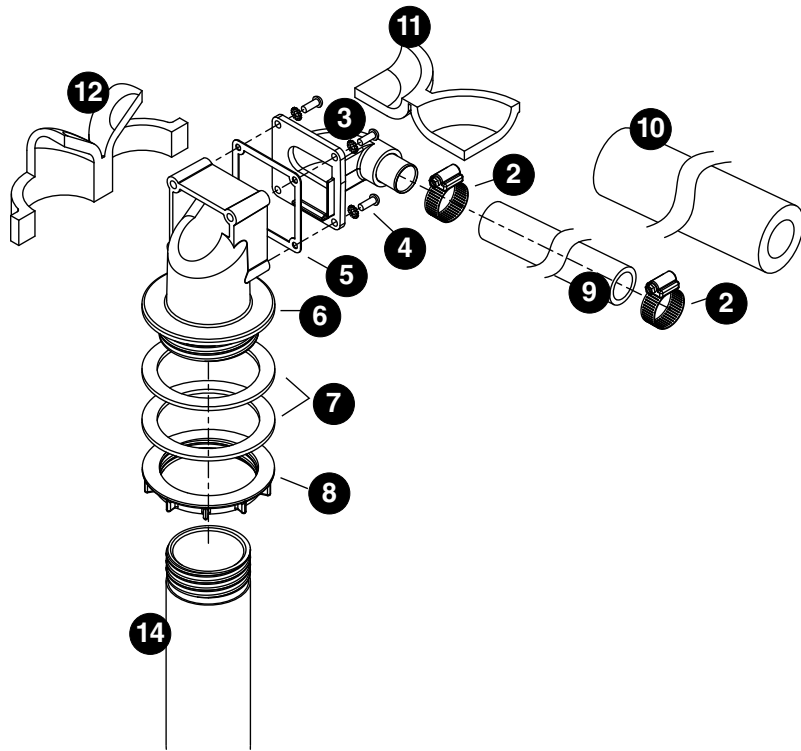

Reference #	Description	Part #
1	Shuttle actuator	00171322
2	Clamp	500377
3	Actuator elbow (includes 00167122 and 209100)	00171264
4	Screws	01303064
5	Gasket	01303072
6	Actuator body	00171272
7	Gasket, coupling	01303080
8	Ring, locking (includes 00126532)	00171371
9	Ice transport tube, 10' (3m)	00171280
9	Ice transport tube, 20' (6m)	00171298
10	Insulation, transport tube	501176
Not shown	Insulated polywire ice transport tube, per foot	00174896
11	Insulation, elbow	01303098
12	Insulation, actuator	01303106
13	Ice transport tube, top mount, 30" (762mm)	00171306
14	Extension-fill tube, 9"	01303114
14	Extension-fill tube, 4"	01303122
Not shown	Integration kit, top mount, Harmony or Bin	00171389
Not shown	Integration kit, RIDE model, Harmony or Bin, (includes 10' (3m) of tube and insulation)	00171397
Not shown	Integration kit, drop in	00145334
Not shown	Integration kit, Cornelius PR150	00144774
Not shown	Integration kit, Vision (does not include ice tube)	00997171
Not shown	Diverter plate (single agitator Cornelius dispensers and left-hand dispense chute on dual-agitator Cornelius dispensers)	01303130
Not shown	Diverter plate (right-hand dispense chute on dual-agitator dispensers)	00996207
Not shown	SafeCLEAN Plus, case of 6	01149954
Not shown	SafeCLEAN Plus, case of 24	01149962
Not shown	Sani-Sponge kit	00132068
Not shown	High-capacity filter system	01303148
Not shown	Primary filter (1)	00978965
Not shown	Primary filter (6)	00978973
Not shown	Pre-filter (1)	00130211
Not shown	Pre-filter (12)	00954305
Not shown	Sponge, sanitary, pack of 24	01075431
Not shown	Kit, IMDV (included IMDV cartridge and communication cable)	01116177

Skins assembly

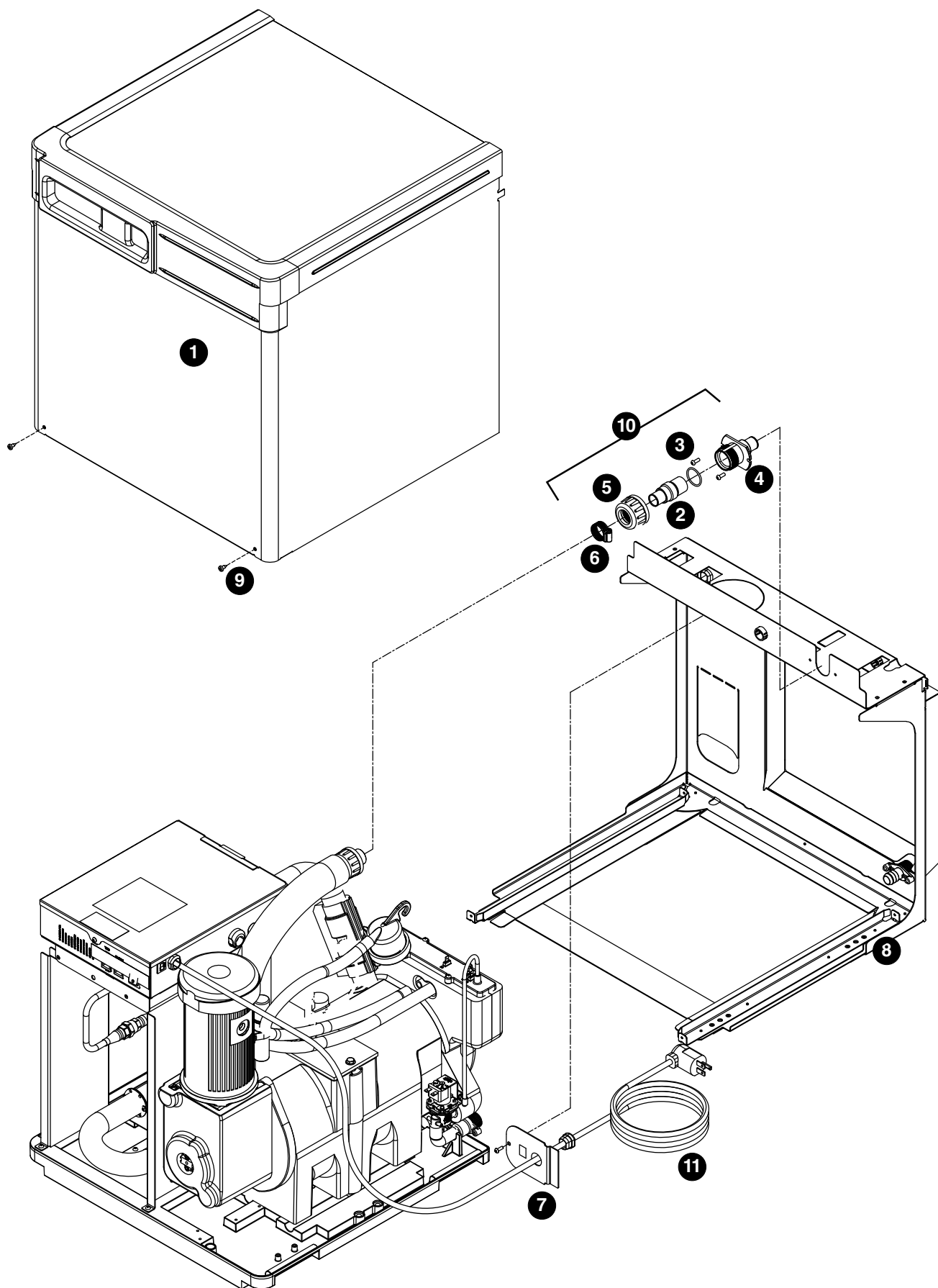

Reference #	Description	Part #
1	Cover, front	01403237
2	Coupling (includes O-ring)	00171207
3	O-ring	01303171
4	Bulkhead fitting	00171215
5	Nut	01303189
6	Hose clamp	500377
7	Plate, strain relief	00192070
8	Docking assembly (includes strain relief plate, bulkhead fitting)	01403245
9	Screw	01303197
10	Bulkhead connector kit	00171223
11	Cord and plug, power	01111491
Not shown	Fitting, drain	00109728
Not shown	Cover, rear (1810)	01403211 (1810 only)
Not shown	Cover, rear (2110)	01403229 (2110 only)

1810 Single-phase condensing unit

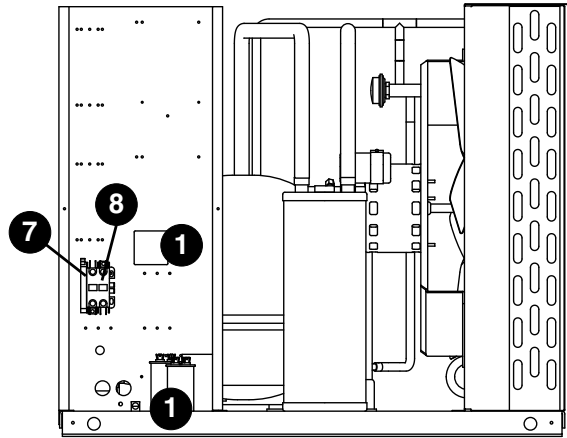
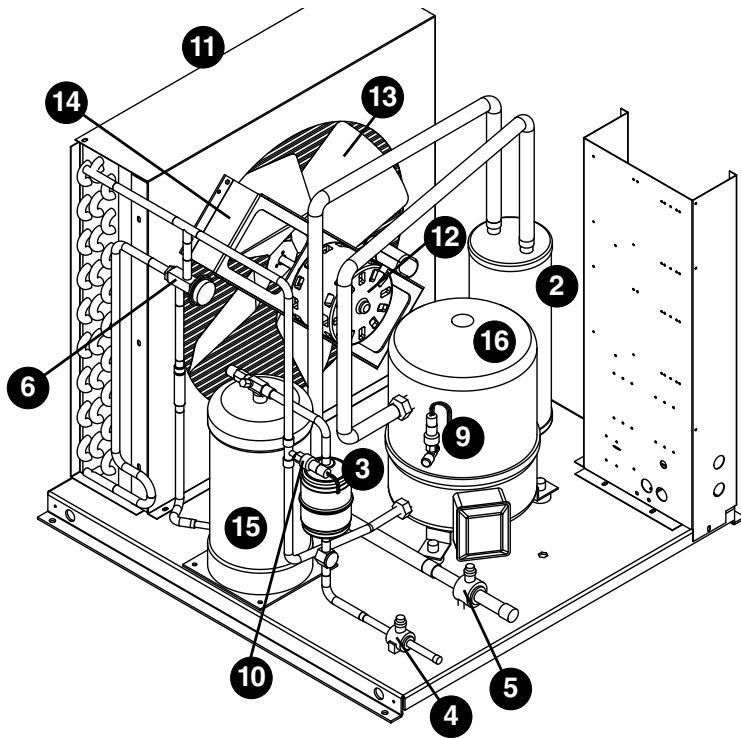

Reference #	Description	Part #
1	Start/Run Kit, 1810 (includes start relay, two run capacitors and a start capacitor)	01170125
2	Accumulator, Suction Line	01170133
Not shown	Valve, Check	01170141
3	Filter/Drier	01170158
4	Valve, Ball, 3/8"	01170166
5	Valve, Ball, 7/8"	01170174
6	Control, Head Pressure	01170182
Not shown	Heater, Crankcase	01170190
7	Contactor Kit (includes both main contactor and aux switch)	01453794
8		
9	Control, Pressure, Low	01170224
10	Control, Pressure, High	01170232
Not shown	Heater, Receiver	01170240
Not shown	Thermostat, Receiver Heater	01170257
11	Coil, Condenser	01170265
12	Motor, Condenser Fan	01170273
13	Blade, Fan	01170281
14	Bracket, Fan Motor	01170299
Not shown	Guard, Hail	01170307
15	Receiver Assembly, Heated	01170331
16	Compressor, 1810, 1PH	01170349

2110 Single-phase condensing unit

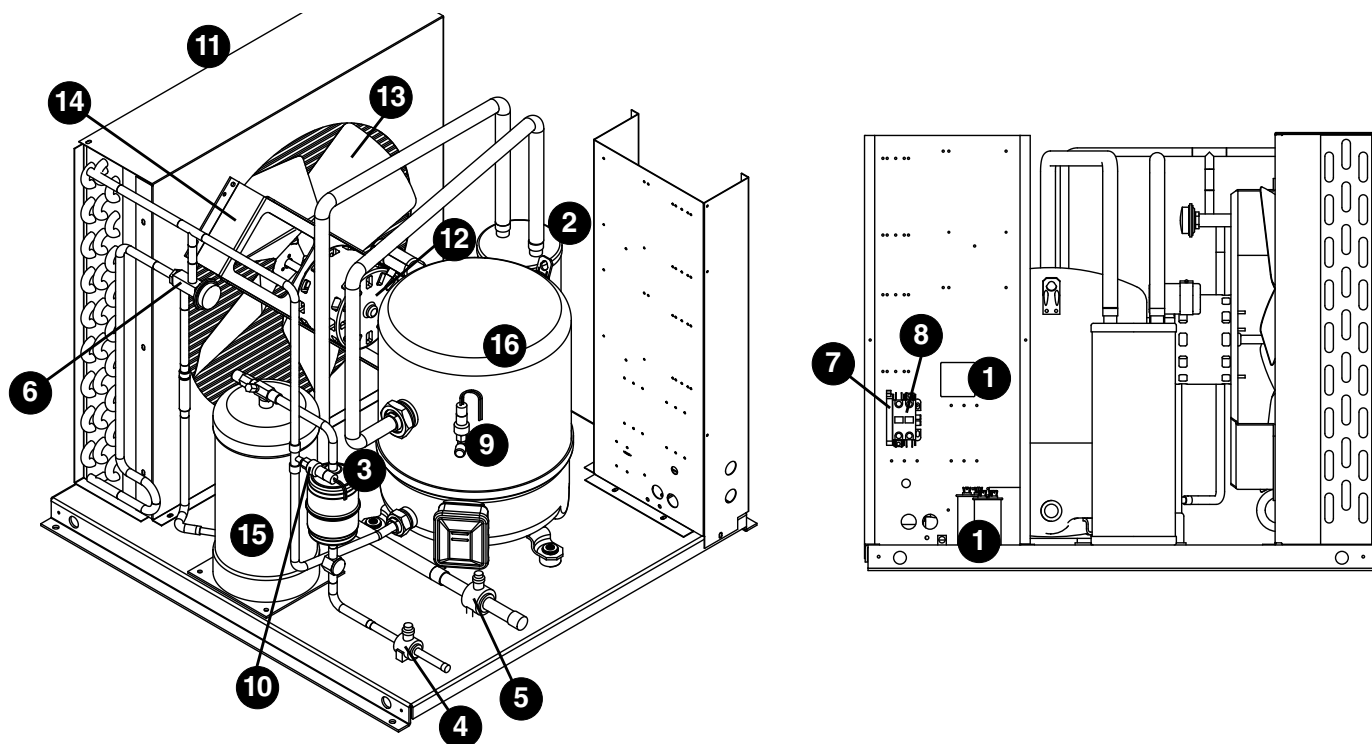

Reference #	Description	Part #
1	Start/Run Kit, 2110 (includes start relay, two run capacitors and a start capacitor)	01170315
2	Accumulator, Suction Line	01170133
Not shown	Valve, Check	01170141
3	Filter/Drier	01170158
4	Valve, Ball, 3/8"	01170166
5	Valve, Ball, 7/8"	01170174
6	Control, Head Pressure	01170182
Not shown	Heater, Crankcase	01170190
7	Contactor Kit (includes both main contactor and aux switch)	01453794
8		
9	Control, Pressure, Low	01170224
10	Control, Pressure, High	01170232
Not shown	Heater, Receiver	01170240
Not shown	Thermostat, Receiver Heater	01170257
11	Coil, Condenser	01170265
12	Motor, Condenser Fan	01170273
13	Blade, Fan	01170281
14	Bracket, Fan Motor	01170299
Not shown	Guard, Hail	01170307
15	Receiver Assembly, Heated	01170331
16	Compressor, 2110, 1PH	01204940

Note: Overload is internal to compressor.

1810 3-phase condensing unit

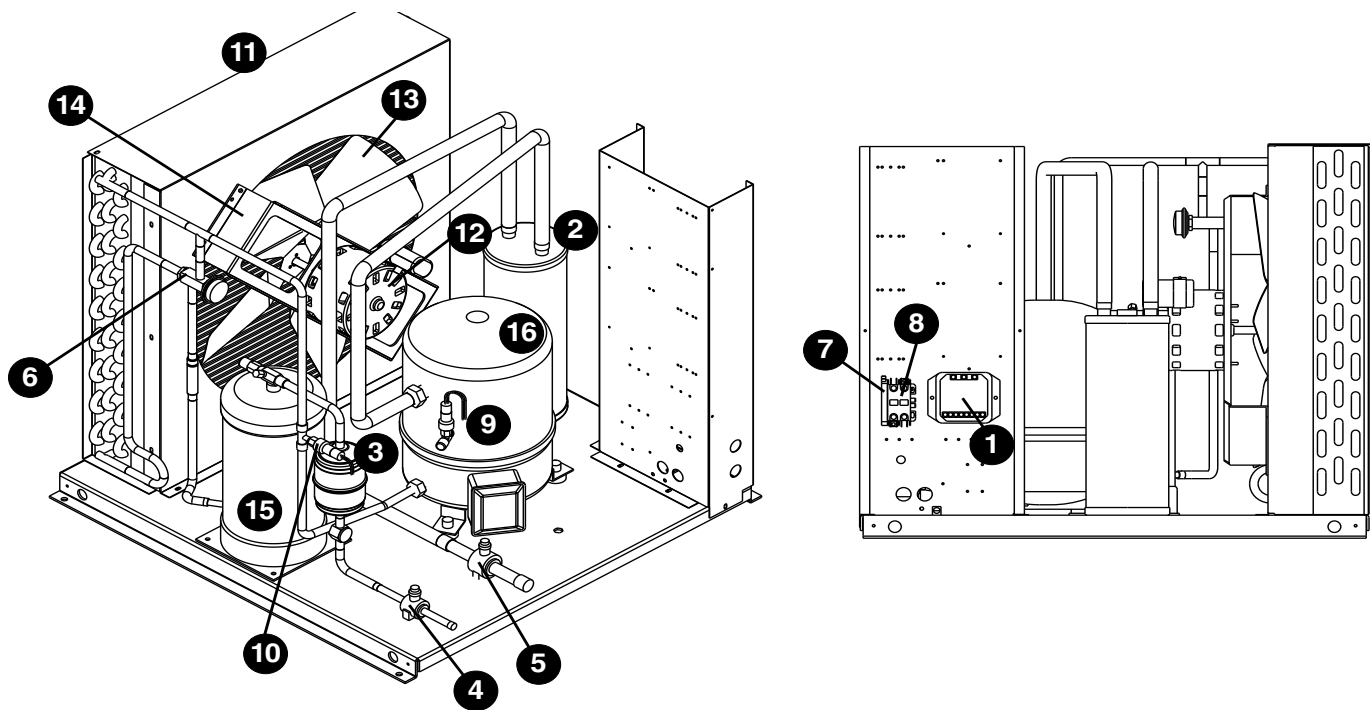

Reference #	Description	Part #
1	Monitor, Phase	01170323
2	Accumulator, Suction Line	01170133
Not shown	Valve, Check	01170141
3	Filter/Drier	01170158
4	Valve, Ball, 3/8"	01170166
5	Valve, Ball, 7/8"	01170174
6	Control, Head Pressure	01170182
Not shown	Heater, Crankcase	01170190
7	Contactor Kit (includes both main contactor and aux switch)	01453778
8		
9	Control, Pressure, Low	01170224
10	Control, Pressure, High	01170232
Not shown	Heater, Receiver	01170240
Not shown	Thermostat, Receiver Heater	01170257
11	Coil, Condenser	01170265
12	Motor, Condenser Fan	01170273
13	Blade, Fan	01170281
14	Bracket, Fan Motor	01170299
Not shown	Guard, Hail	01170307
15	Receiver Assembly, Heated	01170331
16	Compressor, 1810, 3PH	01170356

2110 3-phase condensing unit

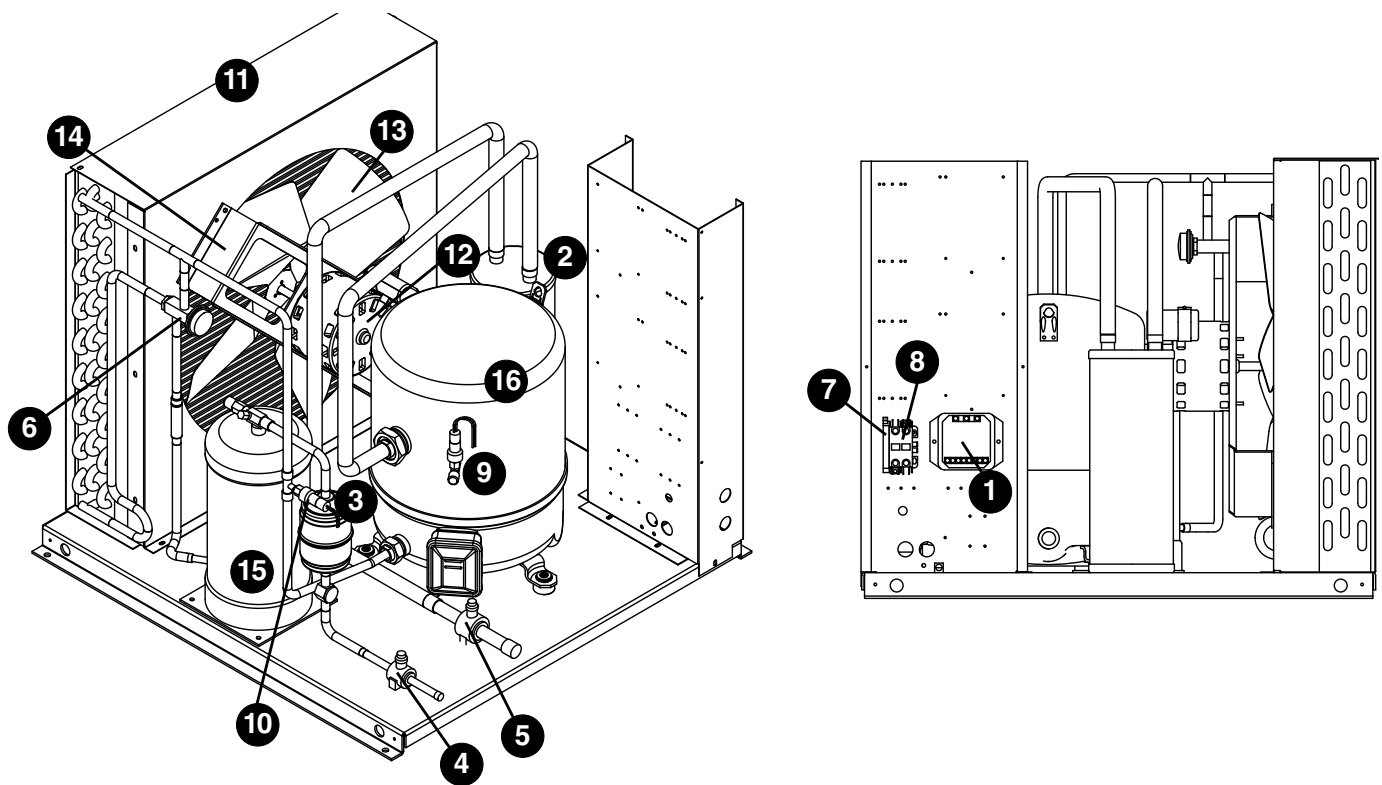

Reference #	Description	Part #
1	Monitor, Phase	01170323
2	Accumulator, Suction Line	01170133
Not shown	Valve, Check	01170141
3	Filter/Drier	01170158
4	Valve, Ball, 3/8"	01170166
5	Valve, Ball, 7/8"	01170174
6	Control, Head Pressure	01170182
Not shown	Heater, Crankcase	01170190
7	Contactor Kit (includes both main contactor and aux switch)	01453778
8		
9	Control, Pressure, Low	01170224
10	Control, Pressure, High	01170232
Not shown	Heater, Receiver	01170240
Not shown	Thermostat, Receiver Heater	01170257
11	Coil, Condenser	01170265
12	Motor, Condenser Fan	01170273
13	Blade, Fan	01170281
14	Bracket, Fan Motor	01170299
Not shown	Guard, Hail	01170307
Not shown	Monitor, Phase	01170323
15	Receiver Assembly, Heated	01170331
16	Compressor, 2110, 3PH	01204924

Note: Overload is internal to compressor.

Rejestracja gwarancji i ocena sprzętu

Dziękujemy za zakup urządzenia firmy Follett. Mamy nadzieję, że nasze urządzenia spełniają i przekraczają Państwa oczekiwania, gdyż naszym celem jest dostarczenie klientom wysoce wartościowych produktów i usług, zasługujących na ich pełne uznanie.

Prosimy zapoznać się z załączoną instrukcją instalacji i obsługi. Istotne jest przeprowadzenie instalacji zgodnie z wymogami producenta, co zapewni działanie urządzenia z maksymalną wydajnością.

Follett LLC nie będzie ponosić odpowiedzialności za szkody wtórne, wydatki, koszty podłączania lub odłączania lub jakiegokolwiek straty wynikające z wady urządzenia.

Aby uzyskać szczegółowe informacje na temat warunków gwarancji, prosimy odwiedzić naszą stronę internetową www.follettice.com/productwarranties.

Rejestracja gwarancji i ocena urządzenia to istotne czynności, ułatwiające nam utrzymanie aktualnych danych o miejscach instalacji naszych urządzeń i o ich działaniu. Prosimy o zarejestrowanie gwarancji na nabyte urządzenie firmy Follett na naszej witrynie www.follettice.com/support, gdzie należy wybrać Warranty Registration (Rejestracja gwarancji) i Equipment Evaluation (Ocena urządzenia). Jest to łatwe i nieskomplikowane, prosimy o znalezienie na to paru minut jeszcze dzisiaj. Na formularzu jest również miejsce na przekazanie nam komentarzy i informacji zwrotnych. Proszę podzielić się z nami swoimi wrażeniami, abyśmy mogli wykorzystać je w naszych ciągłych dążeniach do usprawnień.

Jesteśmy dumni z naszych znakomitych urządzeń i staramy się usilnie wspierać je znakomitą obsługą klienta i wsparciem technicznym. Chcielibyśmy wiedzieć, w jaki jeszcze sposób moglibyśmy Państwu pomóc. Z przyjemnością odpowiemy na Państwa pytania.

Registro de Garantía y Evaluación del Equipo

Gracias por haber elegido este producto Follett®. Esperamos que nuestro equipo cumpla o supere sus expectativas porque es nuestro objetivo ofrecer productos y servicios de gran valor que se ganen su plena confianza.

Le rogamos consulte el manual de instalación y de instrucciones adjunto, ya que es muy importante que la instalación se realice según las especificaciones de fábrica para que el equipo funcione a su máxima eficiencia.

Follett LLC no se hace responsable de los daños indirectos, costos, gastos por conexión y desconexión o pérdidas por causa de defecto de la máquina.

Si desea una información más completa sobre la garantía, visite nuestro sitio web www.follettice.com/productwarranties.

Las operaciones de registro de la garantía y evaluación del equipo son importantes para que podamos realizar un seguimiento de nuestro equipo y registrar el rendimiento de la maquinaria. Por favor, registre las garantías del equipo Follett en nuestro sitio web www.follettice.com/support y seleccione Registro de la Garantía y Evaluación del Equipo. Es muy sencillo, solo le llevará un momento realizar hoy mismo el registro. En el formulario incluimos un espacio en blanco para sus comentarios y opiniones. Infórmenos sobre su experiencia para que podamos incorporarla a nuestros continuos esfuerzos de mejora.

Nos enorgullecemos de producir un equipo excepcional y trabajamos duro para respaldarlo con un soporte técnico y un servicio de atención al cliente de primera. Le rogamos nos indique qué más podemos hacer para ayudarlo. Estaremos encantados de responder a sus dudas.

Enregistrement de la garantie et évaluation de l'équipement

Merci d'avoir acheté un équipement Follett®. Notre objectif étant d'offrir des produits et des services de grande valeur vous satisfaisant pleinement, nous espérons que celui-ci satisfera, voire dépassera, vos attentes !

Veuillez consulter le manuel d'installation et d'exploitation. Il est important que l'installation soit réalisée conformément aux spécifications de l'usine, de sorte que votre équipement fonctionne à son rendement maximum.

Follett LLC n'est pas responsable de tout dommage consécutif, de toute dépense, de tout frais de raccordement ou de déconnexion, ni de toute perte liée à un défaut de la machine.

Pour lire la garantie dans son ensemble, visitez notre site Internet www.follettice.com/productwarranties.

L'enregistrement de la garantie et l'évaluation de l'équipement sont importants pour nous aider à suivre notre équipement et pour enregistrer les performances de la machine. Nous vous demandons donc d'enregistrer la garantie de votre équipement Follett sur notre site Internet, www.follettice.com/support, dans la section Warranty Registration and Equipment Evaluation. Cette opération est simple ; veuillez prendre un moment pour la réaliser aujourd'hui.

Le formulaire contient également un espace pour nous faire parvenir vos commentaires et un retour d'informations. Veuillez nous faire part de votre expérience pour que nous puissions prendre appui dessus pour poursuivre nos efforts constants d'amélioration.

Nous sommes fiers de produire des équipements exceptionnels et nous travaillons avec acharnement pour y associer une assistance à la clientèle et technique exceptionnelle. N'hésitez pas à nous indiquer dans quelle mesure nous pouvons vous aider. Nous serions ravis de répondre à vos questions.

Garantieregistrierung und Produktbeurteilung

Vielen Dank, dass Sie sich für ein Follett®-Produkt entschieden haben. Wir hoffen, dass unser Produkt Ihre Erwartungen erfüllen oder sogar übertreffen wird, weil wir uns zum Ziel gesetzt haben, hochwertige Produkte und Leistungen anzubieten, die Ihre uneingeschränkte Anerkennung verdienen werden!

Lesen Sie sich bitte die beiliegende Installations- und Betriebsanleitung durch. Es ist wichtig, dass die Installation entsprechend den Werksangaben erfolgt, damit Ihr Produkt mit maximalem Wirkungsgrad arbeiten kann.

Follett LLC ist nicht für Folgeschäden, Ausgaben, Gebühren für Anschluss oder Abschaltung oder Verluste aufgrund eines Defekts der Maschine haftbar.

Vollständige Garantieinformationen finden Sie auf unserer Website unter www.follettice.com/productwarranties.

Garantieregistrierung und Produktbeurteilung sind wichtig, damit wir einen Überblick über unsere Produkte behalten und ihre Effizienz bewerten können. Wir möchten Sie bitten, Garantien für Follett-Produkte auf unserer Website www.follettice.com/support zu registrieren und den Punkt „Garantieregistrierung und Produktbeurteilung“ zu wählen. Es ist ganz einfach. Nehmen Sie sich bitte einen Moment Zeit, um die Registrierung heute vorzunehmen. Auf dem Formular ist auch Platz für Kommentare und Feedback vorhanden. Teilen Sie uns bitte Ihre Erfahrungen mit unseren Produkten mit, damit wir sie für unsere fortlaufenden Produktverbesserungen verwenden können.

Wir sind stolz darauf, dass wir besondere Produkte herstellen, und wir bemühen uns, unsere Produkte mit besonderem Kundendienst zu unterstützen. Lassen Sie uns bitte wissen, was wir noch für Sie tun können. Wir werden Ihre Fragen gerne beantworten.

Registrazione della garanzia e valutazione dell'attrezzatura

Grazie per aver acquistato un dispositivo Follett®. Ci auguriamo che il nostro prodotto soddisfi o superi le Sue aspettative, in quanto il nostro obiettivo è quello di offrire prodotti e servizi di alta qualità che soddisfino pienamente le vostre esigenze!

La preghiamo di leggere attentamente il manuale per l'installazione e per l'uso allegato. È infatti importante che l'installazione sia effettuata secondo le specifiche di fabbrica in modo tale che il dispositivo operi con la massima efficienza.

La Follett LLC non si assume alcuna responsabilità per danni conseguenti, spese, costi di collegamento o scollegamento o eventuali perdite dovute ad un difetto della macchina.

Per visualizzare i dettagli completi relativi alla garanzia, recarsi alla pagina www.follettice.com/productwarranties.

La registrazione della garanzia e la valutazione dell'attrezzatura sono importanti per aiutarci a tenere traccia dei nostri dispositivi e a registrare le prestazioni della macchina. Le chiediamo dunque di registrare le garanzie relative al dispositivo Follett sul nostro sito Web alla pagina www.follettice.com/support scegliendo Registrazione della garanzia e Valutazione dell'attrezzatura. Farlo è semplice; dedichi pochi minuti a registrare il prodotto oggi stesso. Sul modulo è inoltre previsto uno spazio in cui potrà fornirci i Suoi commenti e il Suo riscontro. Ci faccia sapere della Sua esperienza in modo che possiamo farne tesoro per il nostro continuo miglioramento.

Siamo orgogliosi di produrre macchinari di ottima qualità e lavoriamo sodo per offrire un servizio di assistenza clienti e tecnico di qualità altrettanto elevata. Ci faccia sapere come possiamo esserle di aiuto. Saremo lieti di rispondere a tutte le Sue domande.

Registo da garantia e avaliação do equipamento

Obrigado por ter adquirido equipamento Follett®. Fazemos votos de que o nosso equipamento cumpra ou exceda as suas expectativas, dado que temos por objetivo fornecer produtos e serviços de elevado valor que mereçam a sua total satisfação!

Pedimos-lhe que leia o manual de instalação e operações em anexo. É importante que a instalação seja levada a cabo de acordo com as especificações da fábrica, para que o seu equipamento funcione com a eficiência máxima.

A Follett LLC não assume a responsabilidade por quaisquer prejuízos indiretos, despesas, custos de ligação ou desligação ou quaisquer outras perdas decorrentes de um defeito na máquina.

Para consultar os dados da garantia, visite o nosso website www.follettice.com/productwarranties.

O registo da garantia e a avaliação do equipamento são importantes para nos ajudar a estar a par do nosso equipamento e registar o desempenho da máquina. Pedimos-lhe que registre as garantias de equipamento Follett no nosso website www.follettice.com/support, em “Warranty Registration and Equipment Evaluation”. É muito simples; tire uns minutos para fazer o registo hoje mesmo. O formulário inclui também espaço para os seus comentários e feedback. Conte-nos a sua experiência para que possamos usá-la nos nossos esforços contínuos de melhoria.

Temos muito orgulho em produzir equipamento excepcional e empenhamo-nos em proporcionar um apoio técnico e um apoio ao cliente igualmente excecionais. Diga-nos o que mais podemos fazer para o ajudar. Teremos todo o prazer em responder às suas perguntas.

Registrering af garanti og evaluering af udstyr

Tak for dit køb af Follett®-udstyr. Forhåbentlig synes du, at vores udstyr lever op til eller overstiger dine forventninger, for vores målsætning er at levere produkter og serviceydelser af høj kvalitet, som du er fuldstændig tilfreds med!

Gennemlæs venligst den vedlagte installations- og driftsmanual. Det er vigtigt at installationen udføres i henhold til fabriksspecifikationerne, så dit udstyr kan fungere med maksimal effektivitet.

Follett LLC hæfter ikke for følgeskader, udgifter, tilslutnings- eller frakoblingsomkostninger eller nogen form for tab, der skyldes en maskindefekt.

Du kan læse de fulde oplysninger om garantien på vores website www.follettice.com/productwarranties.

Registrering af garantien og evaluering af udstyret er vigtigt for at hjælpe os med at følge op på vores udstyr og registrere maskinens ydelse. Vi beder dig registrere garantier på Follett-udstyr på vores website www.follettice.com/support og vælge Warranty Registration and Equipment Evaluation (Registrering af garanti og evaluering af udstyr). Det er nemt at gøre, så vi beder dig bruge et øjeblik på at registrere dig i dag. Formularen har også plads til, at du kan give os kommentarer og feedback. Fortæl os om dine erfaringer, så vi kan bruge dem i vores fortsatte bestræbelser på at forbedre os.

Vi sætter en ære i at fremstille udstyr i særklasse og arbejder hårdt på at kunne bakke udstyret op med fremragende kundeservice og teknisk support. Fortæl os, hvad vi ellers kan gøre for at hjælpe dig. Vi svarer gerne på dine spørgsmål.

Registratie van garanties en beoordeling van apparatuur

Gefeliciteerd met uw aankoop van Follett®-apparatuur. We hopen dat onze apparatuur uw verwachtingen invult of zelfs overstijgt, omdat we ernaar streven om hoogwaardige producten en diensten te leveren die u uitermate tevreden stellen!

Lees de bijgevoegde installatie- en bedieningshandleiding zorgvuldig door. Het is belangrijk dat de installatie uitgevoerd wordt volgens de fabrieksspecificaties, zodat uw apparatuur zo efficiënt mogelijk werkt.

Follett LLC is niet aansprakelijk voor enige gevolgschade, uitgaven, montage- of demontagekosten of enige door een defect van de machine geleden verliezen.

Bezoek onze website www.follettice.com/productwarranties voor alle garantiegegevens.

De registratie van garanties en de beoordeling van apparatuur is belangrijk voor ons om onze apparatuur te helpen traceren en de prestaties van de machine te registreren. We verzoeken u dan ook om garanties van Follett-uitrusting te registreren op onze website www.follettice.com/support en om “Warranty Registration” (Registratie van garanties) en “Equipment Evaluation” (Beoordeling van apparatuur) te kiezen. Gelieve hier even tijd voor vrij te maken. Het is namelijk zeer eenvoudig. Er is op het formulier ook plaats om opmerkingen en feedback te geven. Breng ons gerust op de hoogte over uw ervaring met onze apparatuur, zodat we ons kunnen blijven verbeteren.

We zijn trots op onze productie van uitstekende apparatuur en werken hard om dit bij te staan door een voortreffelijke klantendienst en technische ondersteuning. Aarzel echter niet om enige andere bijstand te vragen. We zullen uw vragen met plezier beantwoorden.

Garantiregistrering och utvärdering av utrustning

Tack för att du köpt utrustning från Follett®. Vi hoppas att du ska tycka att den uppfyller eller överträffar dina förväntningar, då vårt mål är att leverera produkter och tjänster av högt värde som gör dig helt nöjd!

Studera medföljande installations- och bruksanvisning. Det är viktigt att installationen genomförs enligt fabriken anvisningar så att din utrustning arbetar med högsta effektivitet.

Follett LLC ansvarar inte för följdskador, kostnader, avgifter eller förluster som orsakats av fel på maskinen.

Fullständiga garantivillkor finns på vår hemsida www.follettice.com/productwarranties.

Garantiregistrering och utvärdering av utrustning är viktig för oss så att vi kan följa upp vår utrustning och dess funktion. Vi vill att du registrerar Folletts utrustningsgaranti på vår hemsida www.follettice.com/support, där du väljer Garantiregistrering och produktutvärdering. Det är enkelt att göra, så ta dig tid en minut och registrera dig idag. Det finns också utrymme på blanketten för kommentarer och synpunkter. Berätta för oss vad du tycker så att vi kan använda det i våra ansträngningar att alltid bli bättre.

Vi är stolta över att producera överlägsen utrustning och vi arbetar hårt med att stötta den med överlägset kundansvar och tekniskt stöd. Tala om för oss vad vi kan göra mer för att hjälpa dig. Vi svarar gärna på dina frågor.

Warranty Registration and Equipment Evaluation

Thank you for purchasing Follett® equipment. We hope you find that our equipment meets or exceeds your expectations, as our goal is to deliver high value products and services that earn your complete satisfaction!

Please review the enclosed installation and operations manual. It is important that the installation be performed to factory specifications, so your equipment operates to its maximum efficiency.

Follett LLC will not be liable for any consequential damages, expenses, connecting or disconnecting charges or any losses resulting from a defect of the machine.

For full warranty details, visit our website www.follettice.com/productwarranties.

Warranty registration and equipment evaluation is important to help us keep track of our equipment and to record the machine's performance. We request that you register Follett equipment warranties on our website www.follettice.com/support and choose Warranty Registration and Equipment Evaluation. It's simple to do; please take a moment to register today. There is also space on the form to provide us with comments and feedback. Please let us know about your experience so we can capture it for our continuous improvement efforts.

We pride ourselves on producing outstanding equipment and we work hard to back it up with outstanding customer and technical support. Please let us know what else we can do to assist you. We would be happy to answer your questions.

Horizon, Horizone Elite, Harmony, Ice Manager, SafeCLEAN, Sani-Sponge and Vision are trademarks of Follett Products, LLC. Chewblet, RIDE and Follett are registered trademarks of Follett Products, LLC, registered in the US.