

# HCD/HMD/HCF/HMF1400R, HCD/HMD1400N Ice Machines

Order parts online  
[www.follettice.com](http://www.follettice.com)

Operation and Service Manual  
Serial Numbers after C33984

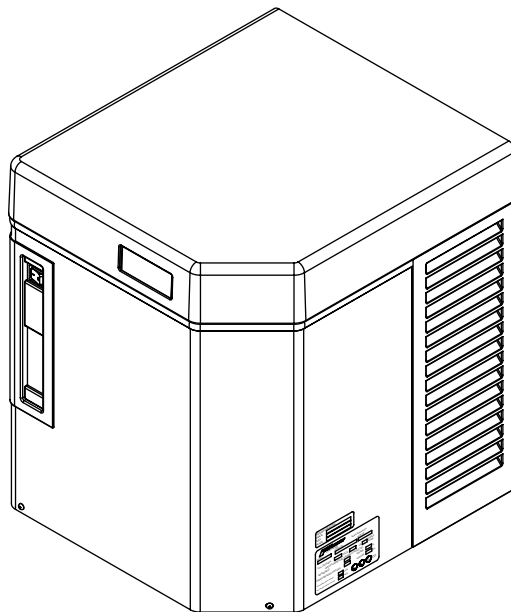

**Following installation, please forward this manual  
to the appropriate operations person.**



# Table of contents

<b>Welcome to Follett Corporation .....</b>	<b>4</b>
<b>Specifications .....</b>	<b>5</b>
<b>Operation.....</b>	<b>7</b>
Cleaning, weekly exterior care .....	7
Cleaning, semi-annual evaporator cleaning .....	7
<b>Service.....</b>	<b>12</b>
Ice machine operation.....	12
Water system.....	13
Electrical system .....	14
Normal control board operation.....	14
Test points .....	15
Error faults.....	15
Hard errors .....	15
Soft errors.....	15
Relay output indication .....	15
Compressor/refrigerant solenoid output.....	15
Wiring diagram, evaporator unit .....	16
Wiring diagram, condenser unit .....	17
Gearmotor data .....	17
Mechanical system.....	18
Evaporator disassembly .....	18
Evaporator reassembly.....	20
Refrigeration system .....	23
Condenser unit operation.....	23
Refrigerant pressure data.....	23
Refrigerant charges.....	23
Refrigeration system diagram.....	24
Refrigerant replacement requirements.....	25
Evacuation.....	25
Ambients (evaporator unit) .....	25
Ice capacity test .....	25
Bin full detection system .....	26
Troubleshooting .....	27
Replacement parts.....	30

# Welcome to Follett

Follett equipment enjoys a well-deserved reputation for excellent performance, long-term reliability and outstanding after-the-sale support. To ensure that this equipment delivers the same degree of service, we ask that you review the installation manual (provided as a separate document) before beginning to install the unit. Our instructions are designed to help you achieve a trouble-free installation. Should you have any questions or require technical help at any time, please call our technical service group at (877) 612-5086 or +1 (610) 252-7301.

## Before you begin

After uncrating and removing all packing material, inspect the equipment for concealed shipping damage. If damage is found, notify the shipper immediately and contact Follett Corporation so that we can help in the filing of a claim, if necessary.

Check your paperwork to determine which model you have. Follett model numbers are designed to provide information about the type and capacity of Follett equipment. Following is an explanation of the different model numbers in the 1400 series.

### Chewblet® Ice Icemaker Model Number Configurations

**HC** **D** **1400** **R** **V** **S**

Icemaker	Voltage	Series	Condenser	Application	Configuration
MC Maestro™ Chewblet (400 Series)	C 208-230/60/1 (icemaking head) <i>Self-contained only.</i>	400 up to 454 lbs (206kg)	A Air-cooled, self-contained W Water-cooled, self-contained	V Vision™ H Harmony™	S RIDE® <i>(RIDE remote ice delivery equipment)</i>
HC Horizon Chewblet (1000, 1400, 1650 Series)	D 115/60/1 (icemaking head) <i>Self-contained and remote. If remote unit, high side is 208-230/60/1.</i>	1000 up to 1036 lbs (471kg)	R Air-cooled, remote condensing unit N Air-cooled, no condensing unit for connection to parallel rack system	B Ice storage bin J Drop-in M Ice Manager™ diverter valve system	T Top-mount
HM Horizon Micro Chewblet	E 230/50/1 (icemaking head) <i>Self-contained only.</i> F 115/60/1 (icemaking head) <i>Remote only. High side is 208-230/60/3.</i>	1400 up to 1450 lbs (658kg) 1650 up to 1580 lbs (717kg)			

### CAUTION

- Moving parts. Do not operate with front cover removed.
- Hot parts. Do not operate with cover removed.
- To reduce risk of shock, disconnect power before servicing.
- Most ice machine cleaners contain citric or phosphoric acid, which can cause skin irritation. Read caution label on product and follow instructions carefully.
- Ice is slippery. Maintain counters and floors around dispenser in a clean and ice-free condition.
- Ice is food. Follow recommended cleaning instructions to maintain cleanliness of delivered ice.

# Specifications

## Electrical

Separate circuit and equipment ground required.

## Evaporator unit

Standard electrical – 115/60/1

Maximum fuse – 15A

Amperage – 6A

## Condensing unit

	Single-Phase	3-Phase
Electrical	208-230 V, 60 Hz	208-230 V, 60 Hz
Maximum Circuit HVACR breaker size	30A	25A
Minimum Circuit Ampacity	20.0A	14.0A

## Evaporator plumbing

3/8" OD push-in water inlet

3/4" MPT

**Notes:** 3/4" vented drain line must slope a minimum of 1/4" per ft (6 mm per 30.4 cm run).

Drain to be hard piped and insulated.

Water shut-off recommended within 10 ft (3 m).

Follett recommends installation of Follett water filter system (P/N 00130286) in ice machine inlet water line.

## Ambient

### Evaporator unit

Air temperature 100 F/38 C max.

50 F/10 C min.

Water temperature 90 F/32 C max.

45 F/7 C min.

Water pressure 70 psi max. (483 kPa)

10 psi min. (69 kPa)

### Condenser unit

Air temperature 120 F/49 C max.

-20 F/-29 C min.

## Refrigeration

3/8" liquid line – insulated

5/8" suction line – insulated

**Note:** Rack system installations require a reserve capacity of 10,000 BTU/hr at 0 F (-18 C) evaporator temperature.

Evaporator pressure regulator (not supplied) is required.

## Weight

### Evaporator unit

190 lb (88 kg)

### Condenser unit

Single-phase: 330 lb (150 kg)

3-phase: 320 lb (145 kg)

## Ice production

Ice machine capacity/24 hrs.

		Ambient Air Temperature F/C						
		F	60	70	80	90	100	
		C	16	21	27	32	38	
Inlet Water Temperature F/C	50	1354	1333	1260	1243	1227	1227	lbs
	10	614	605	571	564	556	556	kg
	60	1293	1272	1225	1208	1192	1192	lbs
	16	586	577	556	548	541	541	kg
	70	1229	1208	1190	1172	1157	1157	lbs
	21	557	548	540	532	525	525	kg
	80	1167	1146	1102	1084	1069	1069	lbs
	27	529	520	500	492	485	485	kg
	90	1107	1060	1013	995	980	980	lbs
	32	502	481	460	451	445	445	kg

## Dimensions and clearances

Entire front of ice machine must be clear of obstructions/connections to allow removal.

1" (26 mm) clearance above ice machine for service.

1" (26 mm) minimum clearance on sides.

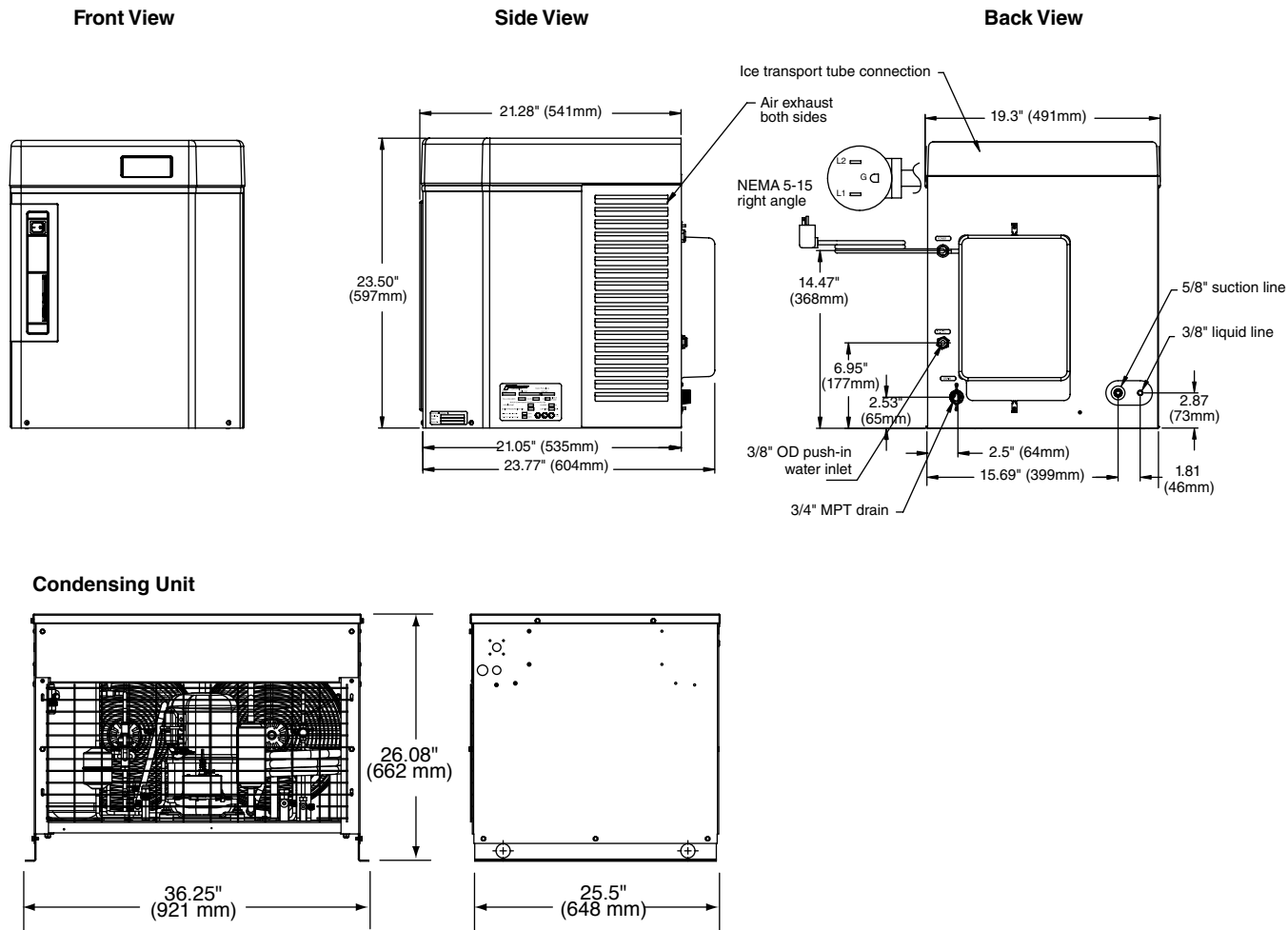

# Operation

## Cleaning and preventive maintenance (all models)

**Note:** Do not use bleach to sanitize or clean the ice machine.

### Preventive maintenance

Periodic cleaning of Follett's ice machine system is required to ensure peak performance and delivery of clean, sanitary ice. The recommended cleaning procedures that follow should be performed at least as frequently as recommended, and more often if environmental conditions dictate.

Cleaning of the ice machine system, in most cases, should be performed by your facility's maintenance staff or a Follett authorized service agent. Regardless of who performs the cleaning, it is the operator's responsibility to see that this cleaning is performed according to the schedule below. Service problems resulting from lack of preventive maintenance will not be covered under the Follett warranty.

### Weekly exterior care

The exterior may be cleaned with a stainless cleaner such as 3M Stainless Steel Cleaner & Polish or equivalent.

### Semi-annual evaporator cleaning (every 6 months)

#### **WARNING**

- Wear rubber gloves and safety goggles (and/or face shield) when handling ice machine cleaner or sanitizer.

#### **CAUTION**

- Use only Follett approved SafeCLEAN™ Cleaner (part #00132001) and NU-CALGON IMS-II or IMS-III SANITIZER.
- Do not mix Cleaner and Sanitizer solutions together.
- DO NOT USE BLEACH.
- It is a violation of Federal law to use these solutions in a manner inconsistent with their labeling.
- Read and understand all labels printed on packaging before use.

**Note: Complete procedure for cleaning and sanitizing MUST be followed. Ice must be collected for 10 minutes before putting ice machine back into service.**

1. To clean – Remove cover. Press the CLEAN button. The machine will drain. Wait for the LO WATER light to come on (Fig. 1).

**Note: For Ice Manager diverter valve application, refer to manual 00175273 for ice machine and diverter valve cleaning process.**

Fig. 1

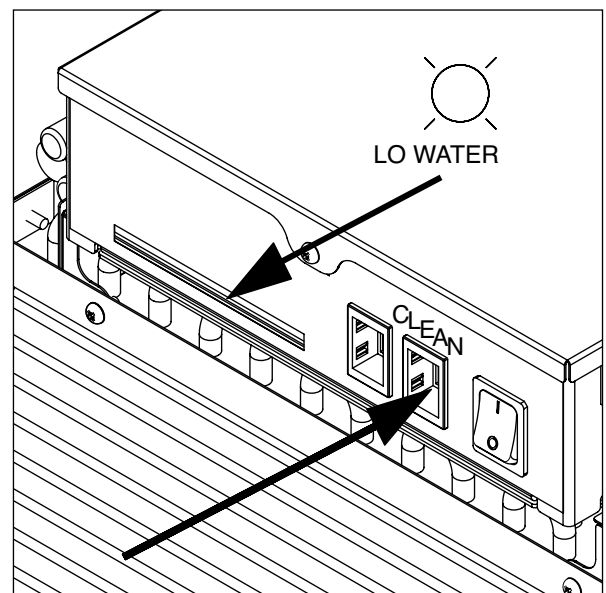

- Mix 1 gallon (3.8 L) 120 F (49 C) water and 7 oz (198 g) (one 7 ounce packet of Follett SafeCLEAN ice machine cleaner, P/N 00132001). Locate cleaning cup. Fill until HI WATER light comes on (Fig. 2).

**Note:** Do not use bleach to sanitize or clean the ice machine.

**Fig. 2**

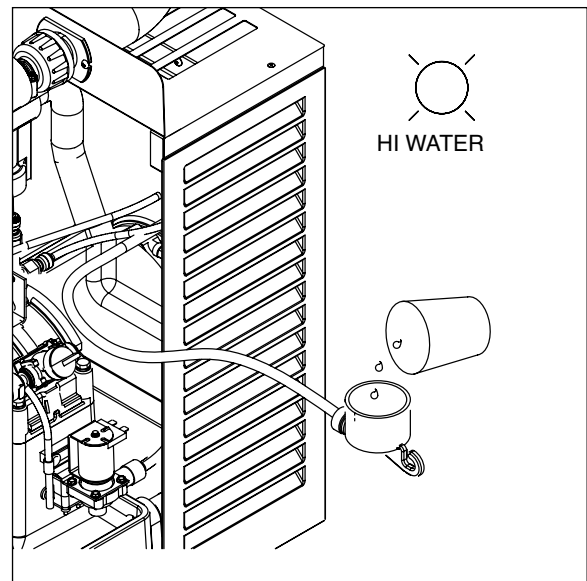

- Replace cover on cleaning cup. Wait until machine restarts. Machine will clean, then flush 3 times in approximately 12 minutes (Fig. 3).

**Fig. 3**

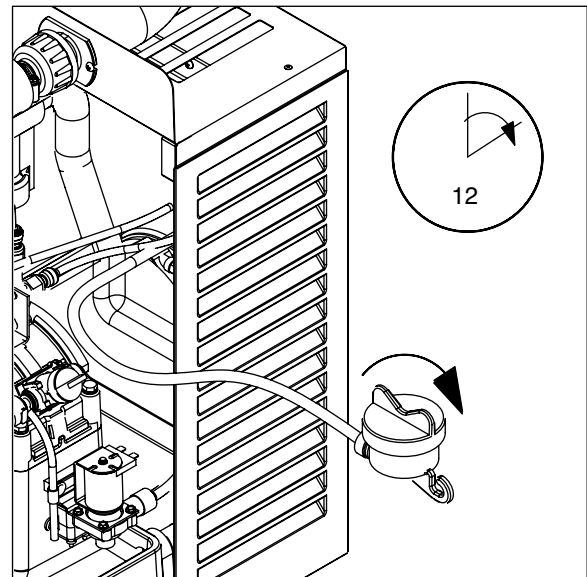

- To sanitize – Press CLEAN button. The machine will drain. Wait for LO WATER light to come on (Fig. 4).

**Fig. 4**

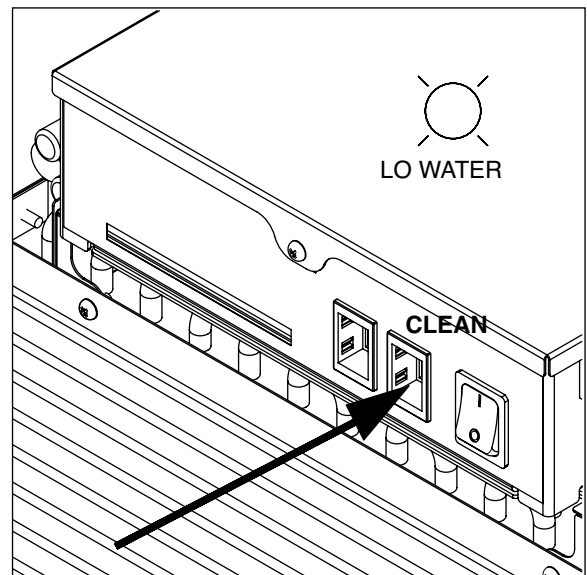



- Mix 1 gallon 120 F (49 C) water and 1.6 oz (48 ml) NU-CALGON IMS-II or IMS-III SANITIZER. Fill until HI WATER light comes on (Fig. 5).

**Note:** Do not use bleach to sanitize or clean the ice machine.

**Fig. 5**

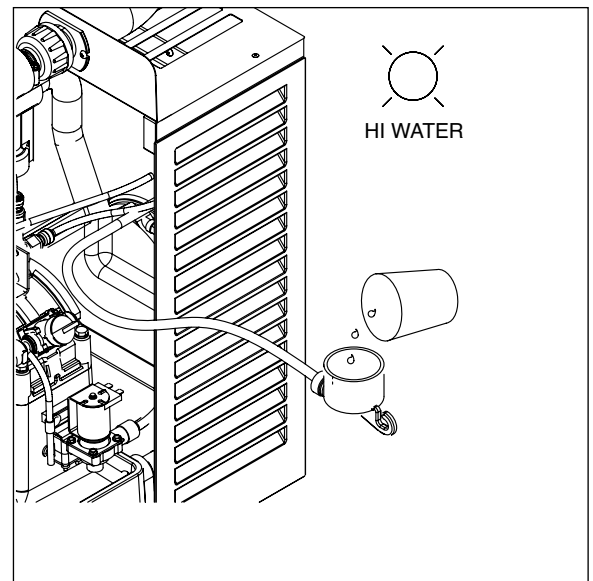

- Replace cover on cleaning cup. Wait until machine restarts. Machine will sanitize, then flush 3 times in approximately 12 minutes (Fig. 6).

**Fig. 6**

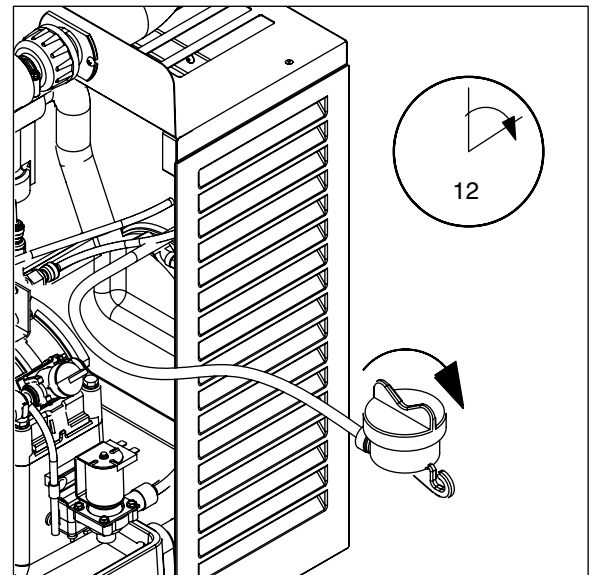

- To clean transport tube – Press power switch OFF (Fig. 7).

**Fig. 7**

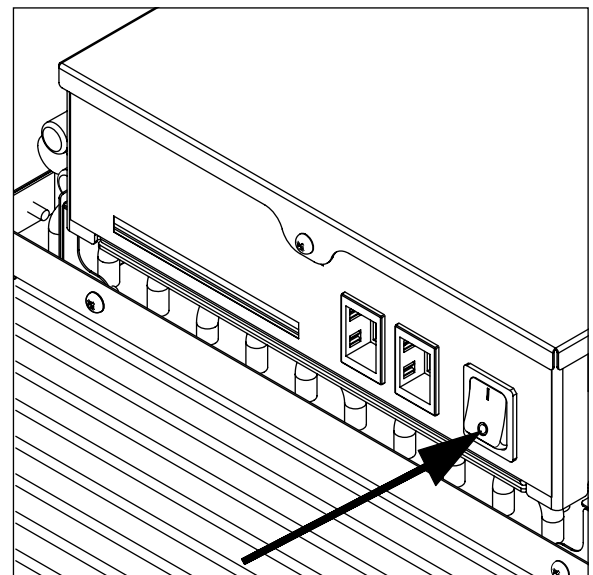

8. Disconnect coupling as shown (Fig. 8).

Fig. 8

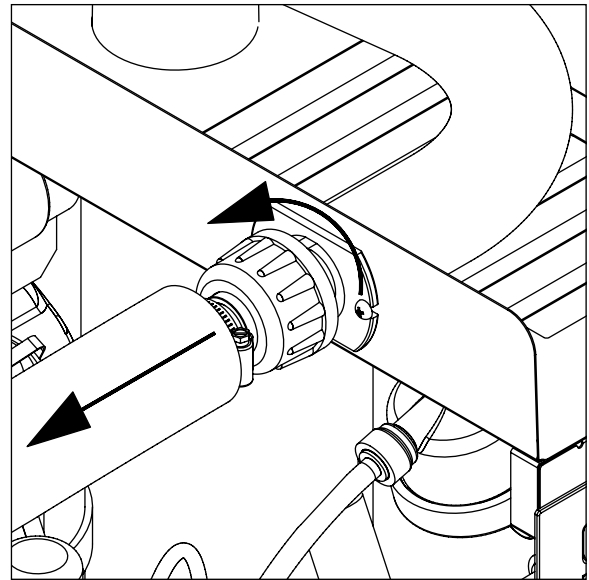

9. Using disposable food service grade gloves, insert dry Sani-Sponge™ (kit P/N 00132068). Next, insert Sani-Sponge soaked in Nu-Calgon IMS-II or IMS-III sanitizer solution. Push both Sani-Sponges down ice transport tube with supplied pusher tube (Fig. 9).

Fig. 9

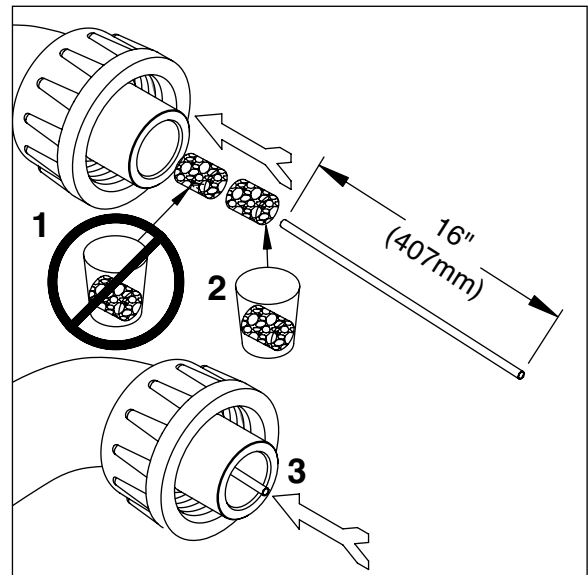

10. Remove and discard 16" (407 mm) pusher tube (Fig. 10).

Fig. 10

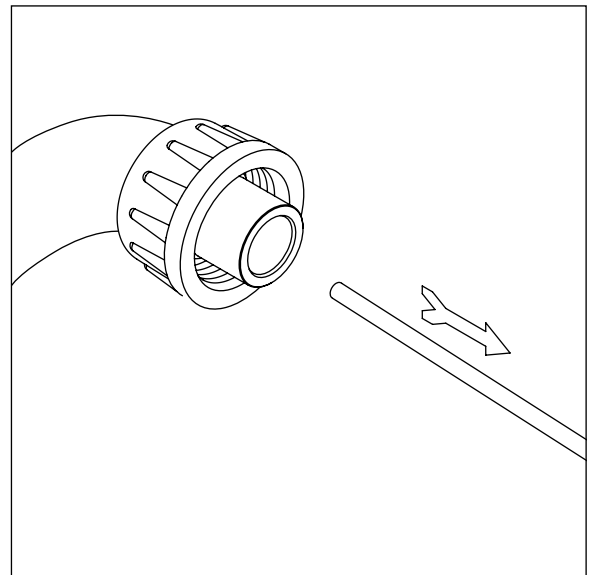

11. Reconnect coupling. Press power switch ON. Ice pushes Sani-Sponges through tube (Fig. 11).

**Fig. 11**

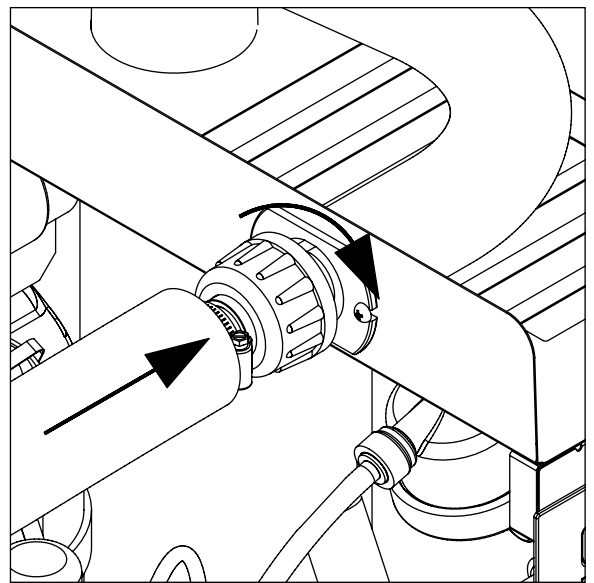

12. Place a sanitary (2 gallon or larger) container in bin or dispenser to collect Sani-Sponges and ice for 10 minutes. Collect 5.5 lb (3 kg) of ice from unit. Discard ice and Sani-Sponges (Fig. 12).

**Fig. 12**

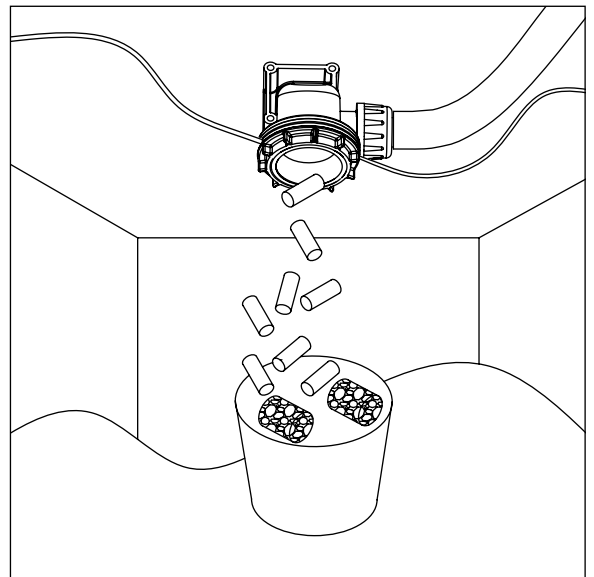

# Service

## Ice machine operation (all models)

Follett's ice machine consists of five distinct functional systems covered in detail as follows:

- Water system
- Electrical control system
- Mechanical assembly
- Refrigeration system
- Bin full

### The Horizon ice machine overview

The Follett Horizon ice machine uses a horizontal, cylindrical evaporator to freeze water on its inner surface. The refrigeration cycle is continuous; there is no batch cycle. The evaporator is flooded with water and the level is controlled by sensors in a reservoir. A rotating auger (22 RPM) continuously scrapes ice from the inner wall of the evaporator. The auger moves harvested ice through the evaporator into an ice extrusion canal. The ice is forced through a restrictive nozzle that squeezes out the water and creates the Chewblet. The continuous extrusion process pushes the Chewblets through a transport tube into a dispenser or bin.

A solid state PC board controls and monitors the functionality of the ice machine. In addition to sequencing electrical components, the board monitors various operational parameters. A full complement of indicator lights allows visual status of the machine's operation. Additionally, the PC board controls the self-flushing feature of the ice machine. The evaporator water is periodically drained and replenished to remove minerals and sediment.

A unique "bin full" detection system is incorporated in the Horizon ice machine. A switch located at the ice discharge port of the machine detects the position of the transport tube. When the bin fills up with ice, the transport tube moves out of the normal running position, and the switch turns the ice maker off. A domed housing at the end of the transport tube contains the ice extrusion loads during shut down.

### Harvest system diagram

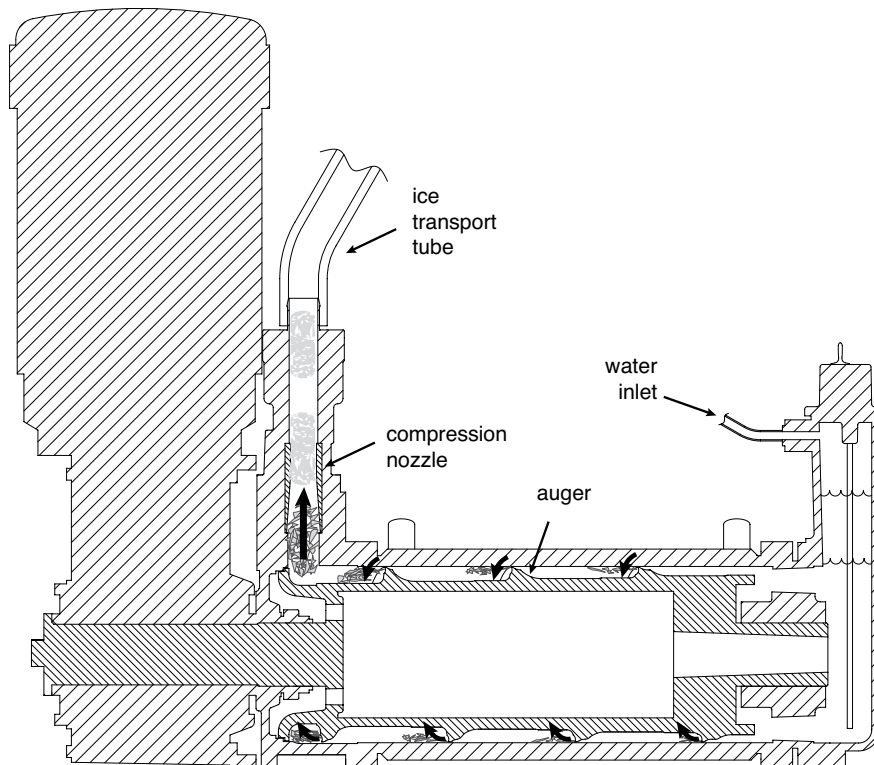

## Water system

The water level in the evaporator is controlled by a feed solenoid and level detecting sensors. Referencing the diagram below, water sensing rods extend down into the reservoir at the end of the evaporator assembly. The system works via electrical conductivity as follows:

One of the longest probes is a common. When water is between any of the other probes and the common, the PC board will sense the activation. During normal operation, the water level rises and falls between the Normal High and Normal Low sensors. As water is consumed to make ice, the level will fall until the Normal Low sensor is exposed, triggering the water feed solenoid on. Water will fill until the Normal High sensor is activated.

Additional sensors are incorporated in the reservoir for alarm and cleaning/flushing conditions.

**Note:** The potable water dissolved solids content must be greater than 10 ppm for the water control system to function properly. If using reverse osmosis water filtration system, ensure T.D.S level is greater than 10 ppm.

## Water system diagram

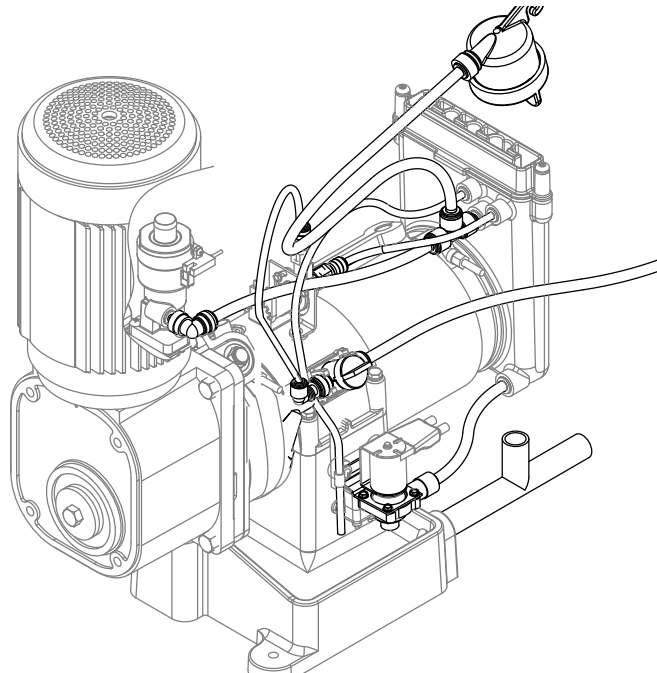

## Water level diagram

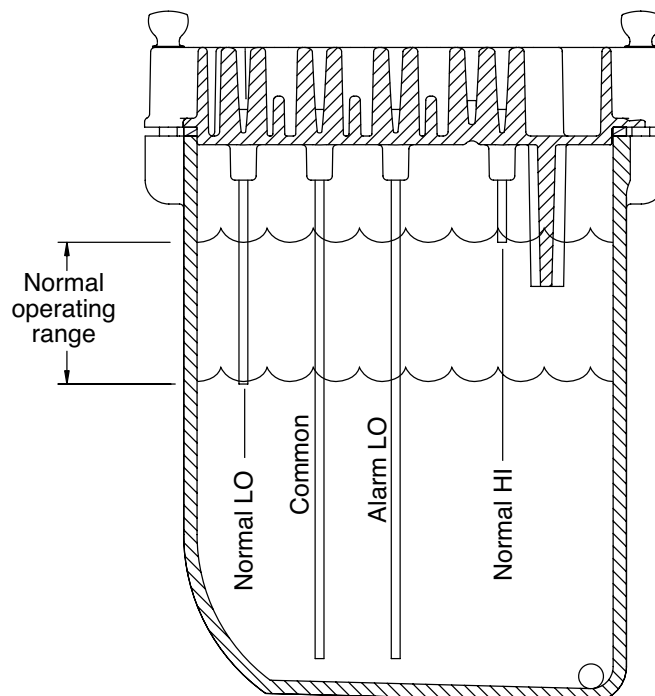

# Electrical system

## Normal control board operation

The PC board indicator lights provide all the information necessary to determine the machine's status. Green indicator lights generally represent "go" or normal operation; Yellow indicators represent normal off conditions; Red indicators generally represent alarm conditions, some of which will lock the machine off.

A green light labeled POWER indicates power to the machine. A flashing green light labeled CPU is normal and indicates that the Central Processing Unit "heart beat" is working. All other normal operation status indicators are covered as follows:

Ice machine disposition	Operating conditions
<b>Legend:</b> ● ON ○ OFF ◐ ON or OFF ✖ FLASHING	

1. Ice machine is making ice.

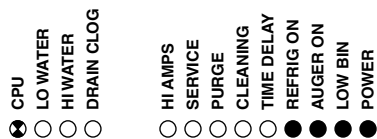

1. **Normal running.**

2. Ice machine is not making ice.

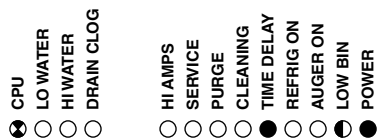

2. **Normal time delay.** When the bin fills with ice, the LOW BIN light goes out and the refrigeration and auger drive systems immediately shut down. The TIME DELAY light comes on, initiating the time delay period. When the time delay expires, the machine will restart provided that the LOW BIN light is on.

3. Ice machine is not making ice.



3. **Normal purge indicator.** After a selected period of ice making time has elapsed (1 or 2 hours), the ice machine will automatically self-flush. The refrigeration system will shut down but the gear motor will continue to run. After the flush is complete the machine will refill and start without a time delay.

**Test points:**

The Horizon PC board incorporates on-board test points that can be used to determine various electrical outputs. The test point holes allow a standard probe to be inserted for quick voltage measurement.

**Error faults:**

The Horizon PC board monitors various operating parameters including high pressure, auger gearmotor amperage limits, clogged drain, and high and low water alarm conditions. There are two types of errors namely "hard" or "soft". A hard error is one that shuts the machine off and will not allow restart until the reset button is pressed. Even cycling power will not reset a hard error. A soft error can either be automatically reset should the condition rectify, or if power is cycled. Should an error occur, consult the troubleshooting guide in this manual or a Follett service technician.

**Note:** there are two types of LO WATER and HI AMPS errors as listed below.

**Soft errors:**

**HI AMPS:** The PC board monitors the amperage of the auger motor. Should the gear motor experience current draw above the 8.4 amps limit the machine will shut down and the TIME DELAY, HI AMP, and SERVICE LED's will be illuminated. After the time delay the machine will restart and the TIME DELAY, HI AMP, and SERVICE LED's will clear.

**LO WATER:** During operation, the water level cycles between the normal low and normal high sensors. Should the water be shut off to a running machine, a soft error will occur. The error sequence is as follows: During operation, the water level falls to the normal low sensor, and when it does the water feed solenoid is energized. If water is not detected at the normal low sensor within 120 seconds, a soft error will occur. The machine will shut down, but the water feed solenoid will remain energized. Should water return, it will fill to the normal low sensor and the machine will resume normal operation. The error will clear automatically.

**DRAIN CLOG:** The drain clog sensor, located in the plastic drain pan behind the drain solenoid, will detect the presence of water just below the top edge of the pan. If water does not properly flow out of the drain pan it will rise to the sensor, especially during a self-flushing purge cycle. Turning the power switch off and then back on again will restart the ice machine.

**Hard error:**

**HI AMPS:**

1. "Two strikes" feature. If the gearmotor has a second HI AMP occurrence during the countdown period (6 hours after a HI AMP time delay) a hard error will occur and the HI AMP and SERVICE LED's will be illuminated. Reset button must be pressed to clear this error.
2. No current. To prevent the refrigeration system from running without gearmotor rotation the PC board will indicate HIGH AMP and SERVICE if the drive relay is energized and there is no current draw. Reset button must be pressed to clear this error.

**HI PRESSURE:** Should the refrigeration pressure rise above 450 psi, the remote condenser's high-pressure switch will shut down the compressor. When the pressure falls back below the reset point of 280 psi, the compressor will restart.

**LO WATER:**

1. There is a sensor in the water reservoir that reaches down to the very bottom. The machine will not start if water is not present at this sensor.
2. A hard error will occur should water not be present within 60 seconds of power up or if the sensors are disconnected or damaged. Reset button must be pressed to clear this error.

**Relay output indication:**

Each relay on the board has an indicator light associated with its output. For example, when the relay for the water feed solenoid is energized, the adjacent indicator light glows green.

**Comp/Sol output:**

The output for the liquid line solenoid is labeled COMP/SOL.

# Evaporator unit wiring diagram

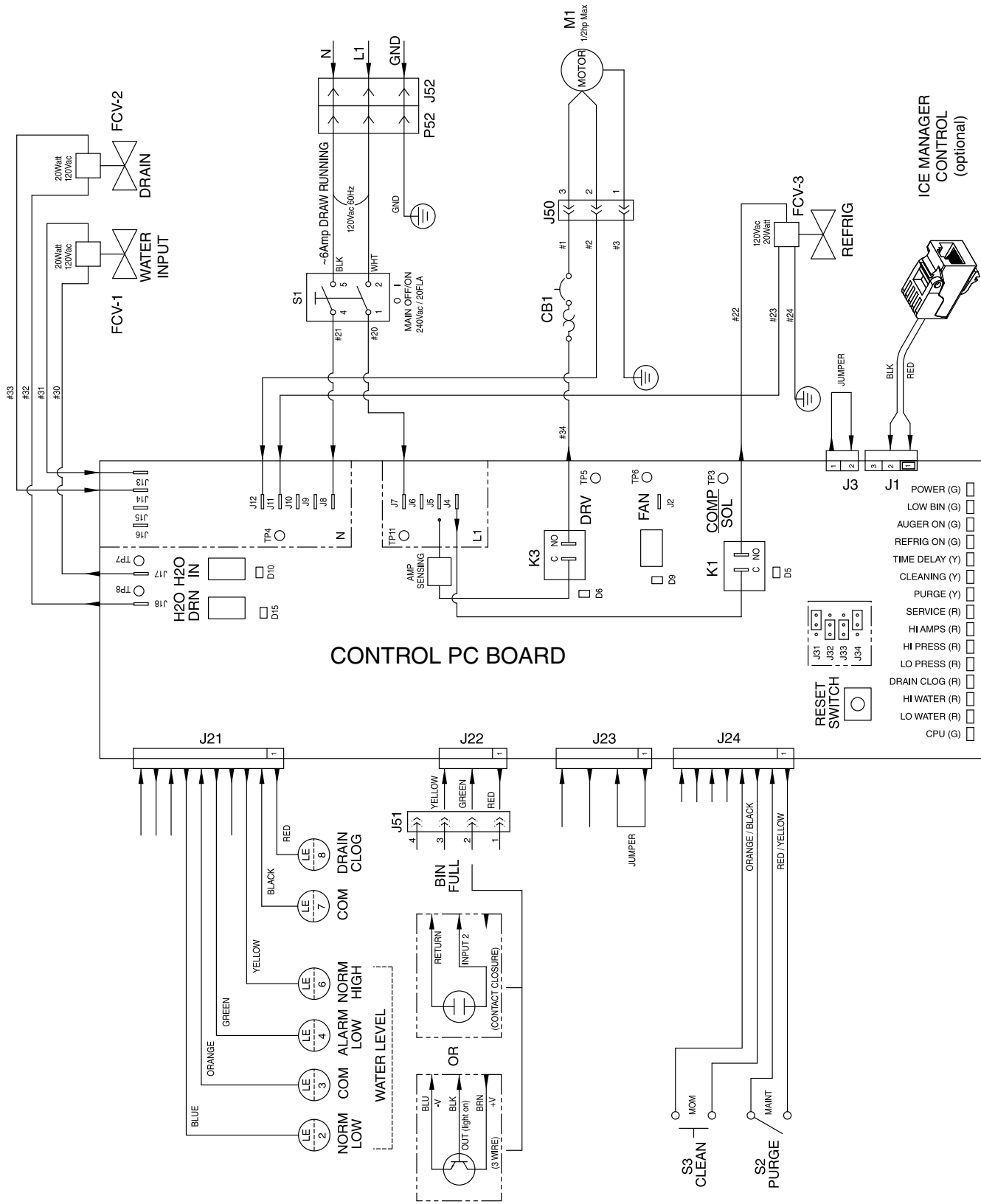

<b>Gearmotor data (Brother)</b>		<b>Resistance of windings</b>	
Gearmotor current	5.0A (nominal)	115 vac gearmotor (Brother)	1.7Ω
Locked rotor amps	15A		



## Single-phase condensing unit wiring diagram

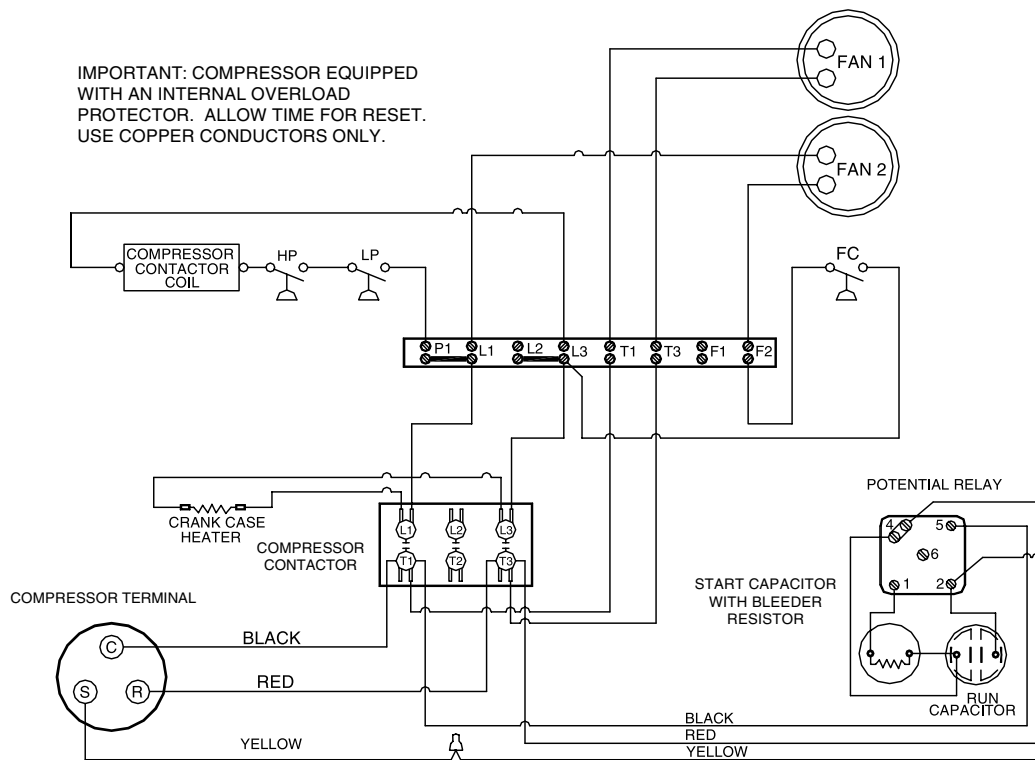

## 3-phase condensing unit wiring diagram

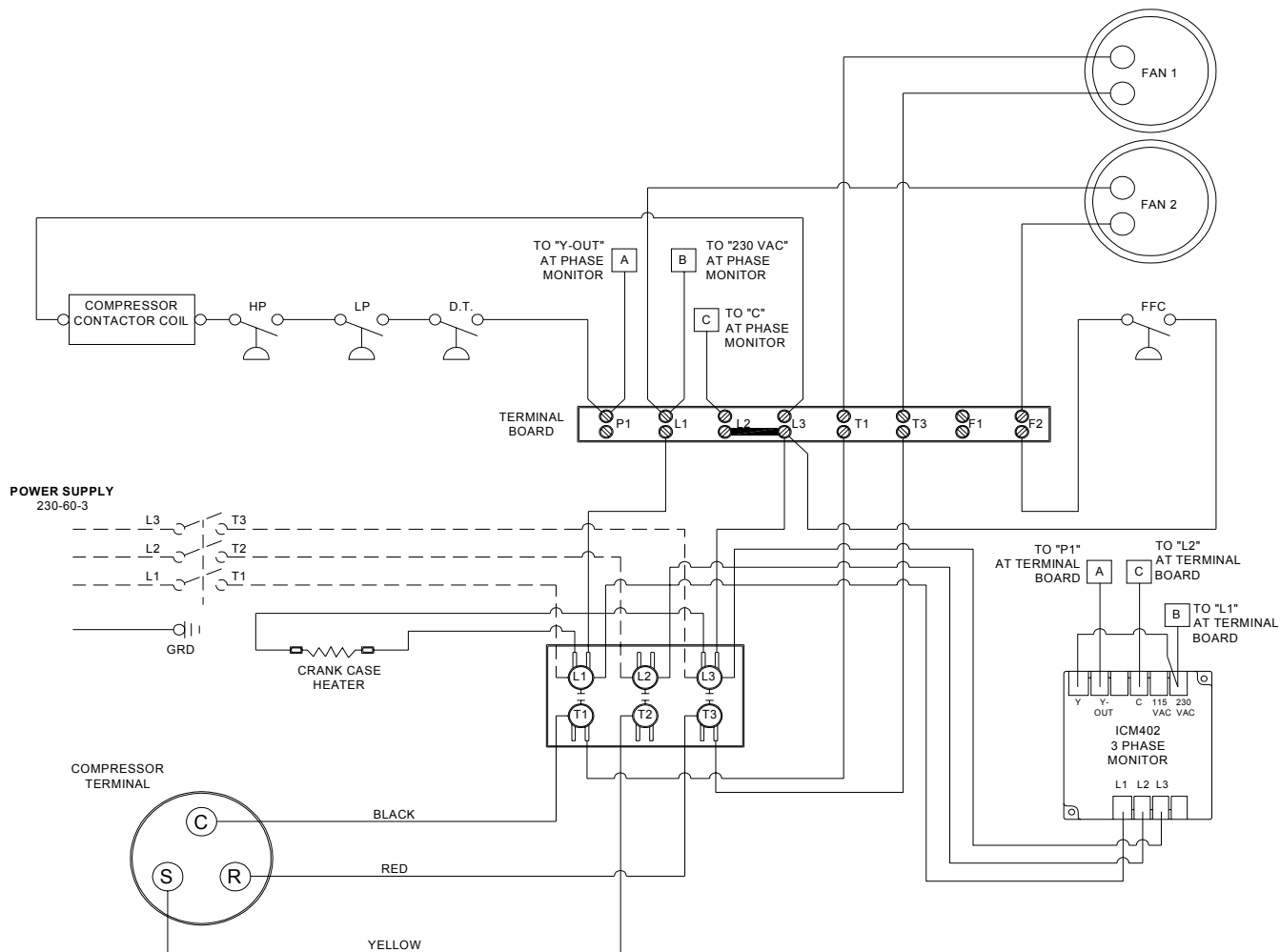

## Mechanical system

### Evaporator disassembly

1. Press PURGE button to purge evaporator, and then turn power OFF.
2. Unscrew and remove stream divider as shown.

Fig. 13

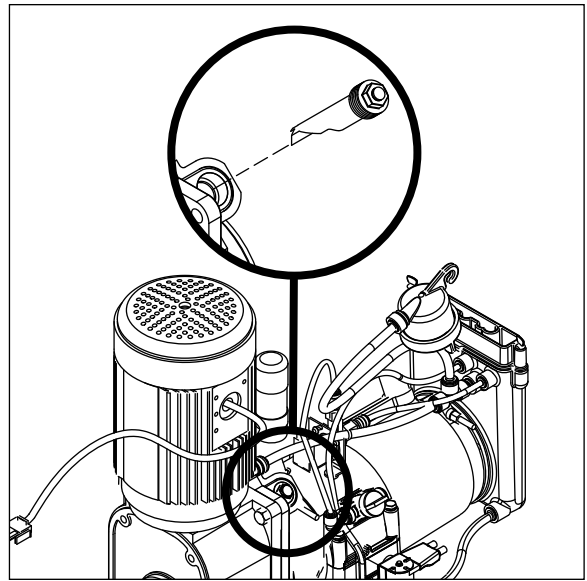

3. Unplug and remove gearmotor as shown.
4. Remove all traces of petrol-gel from the auger shaft.

Fig. 14

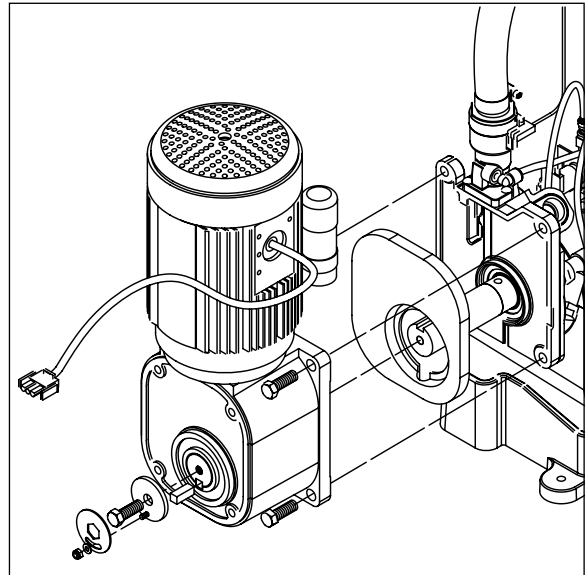

5. Unscrew and disconnect transport tube from louvered docking assembly.
6. Unplug sensor at the electrical box.
7. Remove vent tube from shuttle housing as shown.

Fig. 15

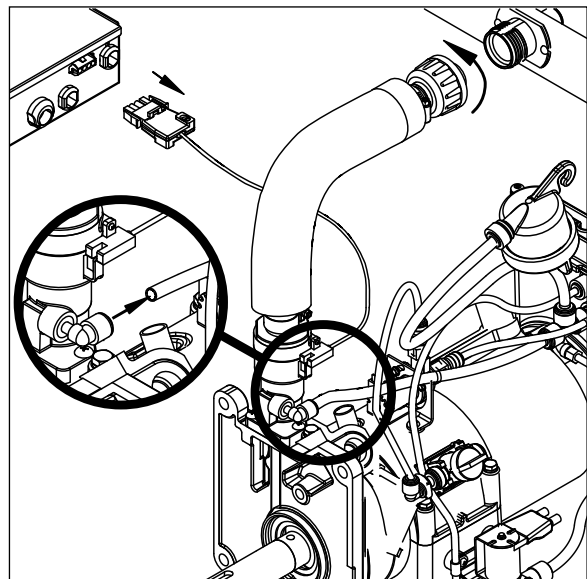

8. Unscrew and disconnect transport tube from louvered docking assembly.
9. Unplug sensor at the electrical box.
10. Remove vent tube from shuttle housing as shown.

**Fig. 16**

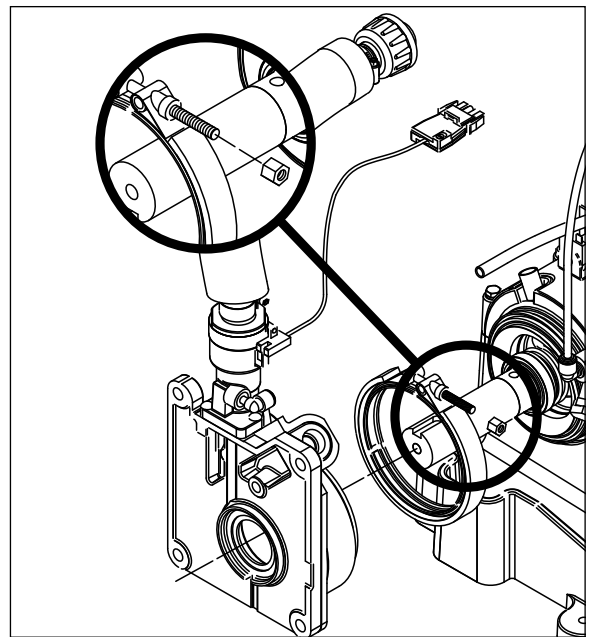

**Fig. 17**

11. Remove and discard mating ring and seal.
12. Carefully remove auger.

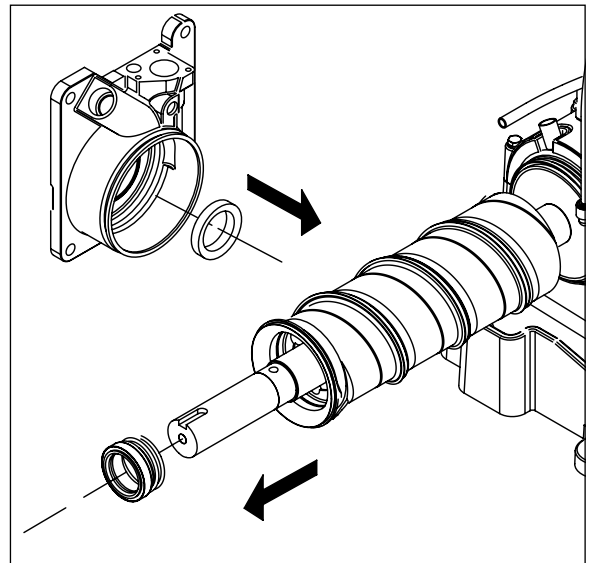

**Fig. 18**

#### **Evaporator reassembly**

1. Remove and inspect O ring seal. Discard if damaged in any way.
2. Clean O ring groove. Lubricate O ring with petrol-gel and reinstall.

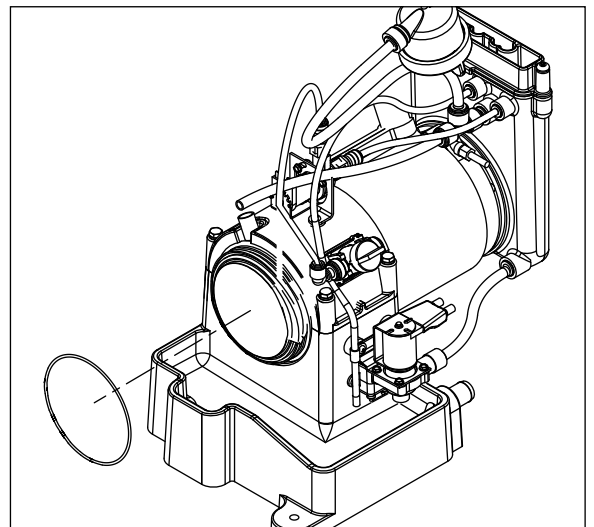

3. Press new mating ring into main housing as shown.
4. Lube the shaft with liquid soap in the area shown and slip on seal and spring.

**Note:** Do not touch the sealing surfaces. Use cardboard disk to install.

**Fig. 19**

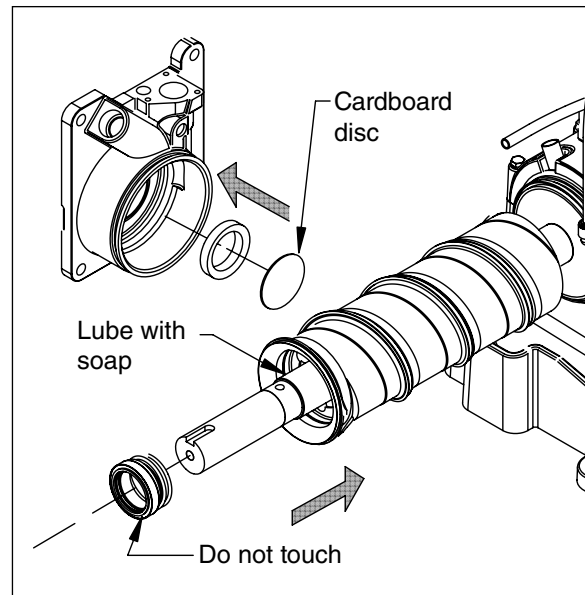

5. Reinstall main housing as shown.

**Fig. 20**

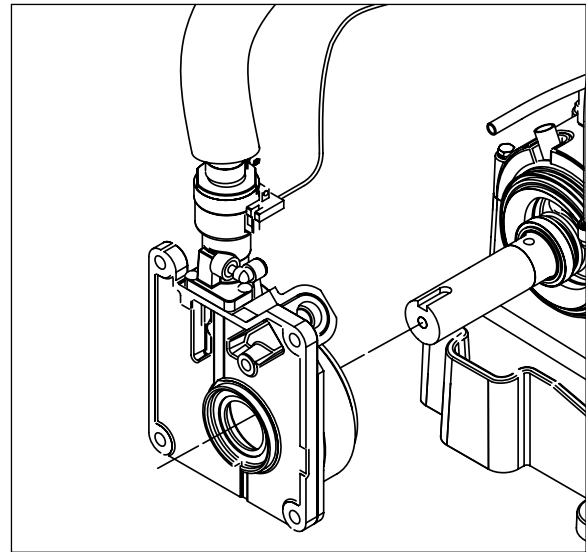

6. Orient auger shaft with keyway in the upward position.
7. Force main housing into position against evaporator and place 1/4" (7 mm) diameter Phillips screwdriver into hole in the auger shaft.
8. Replace V-band clamp as shown.
9. Replace nut on V-band clamp and tighten.
10. Remove screwdriver.

**Fig. 21**

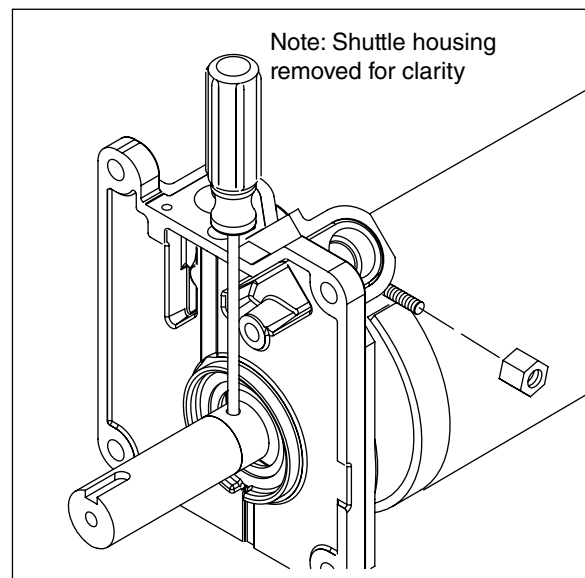

- 11. Reconnect transport tube to louvered docking assembly.
- 12. Plug sensor in at the electrical box.
- 13. Reconnect vent tube to the shuttle housing as shown.

**Fig. 22**

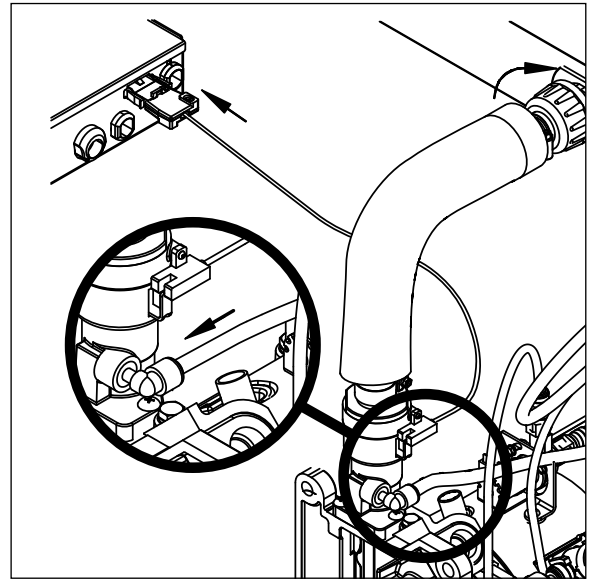

- 14. Apply a coat of petrol-gel to the auger shaft.
- 15. Install gearmotor, making sure that insulation is properly seated between gearmotor and main housing as shown.
- 16. Firmly tighten four gearmotor bolts in place.

**Fig. 23**

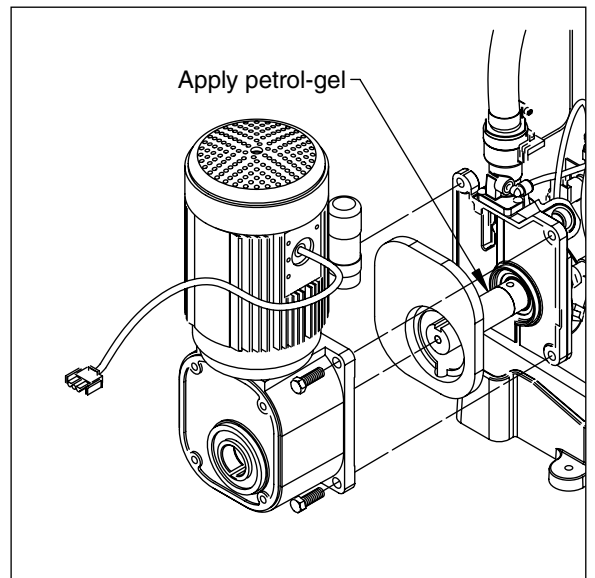

- 14. Insert a bolt into the auger shaft and finger tighten.
- 15. Using a wrench, rotate the shaft clockwise to align the keyways in the gear housing and the shaft so as to accept the key.
- 16. Insert the key into the keyway.

**Fig. 24**

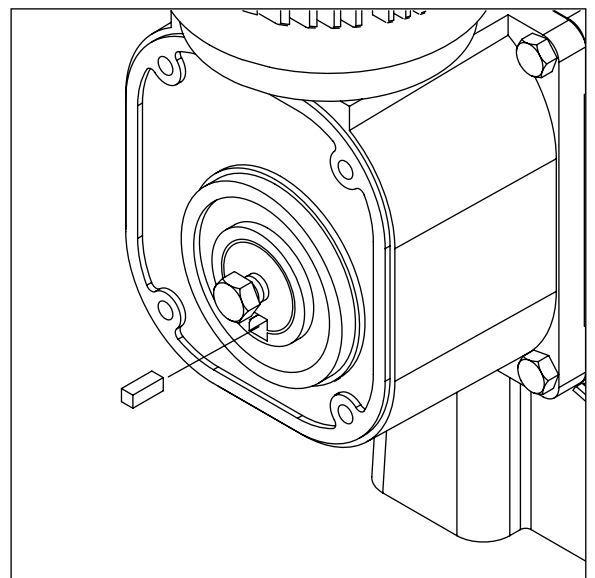

17. Remove bolt and reinstall the washer and bolt. Place retainer over bolt and secure with nut and washer.

Fig. 25

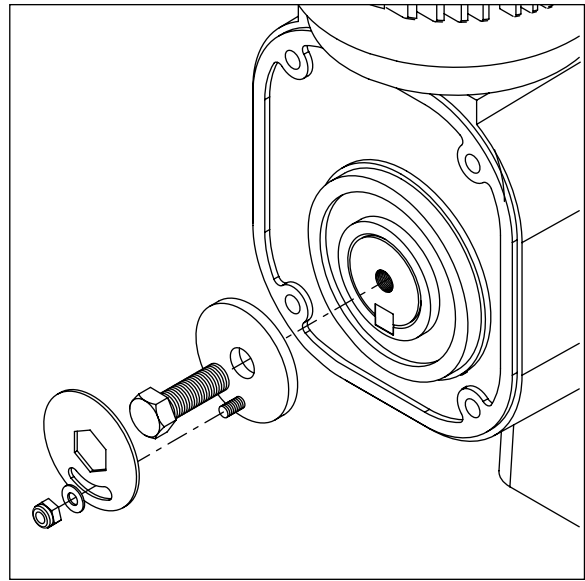

18. Lubricate body of stream divider with petrol-gel and reinstall.  
19. Plug gearmotor power cord into electrical box

Fig. 26

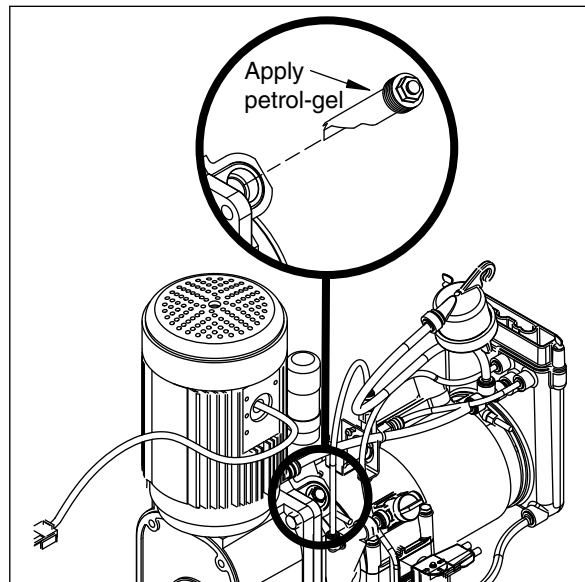

# Refrigeration system

## Condenser unit operation

The condensing unit is weatherproof and equipped to operate in ambient temperatures from -20 F to 120 F (-29 C to 48.9 C). The condensing unit is controlled by a low pressure control, which works in concert with a refrigerant solenoid valve on the evaporator module. On start-up, the refrigerant solenoid valve opens and suction pressure rises above the “on” set point of the control. The compressor and fan turn on and the refrigeration system operates. Upon shut down, the refrigerant solenoid closes. The compressor will pump down the ice machine evaporator and suction line until the low “off” set point is reached, at which point the compressor and fan will turn off.

Low ambient operation: Reliable operation at low outdoor ambient temperature is achieved with a pumpdown cycle, a crankcase heater and a head pressure control valve. When the outdoor ambient falls, the condensing pressure falls. This causes the discharge pressure to fall as well. When the discharge pressure falls below the dome pressure, the valve modulates open to the discharge port which allows discharge gas to bypass the condenser. Mixing the discharge gas with the liquid creates a high pressure at the condenser outlet, reducing the flow and causing liquid to back up in the condenser. Flooding the condenser reduces the area available for condensing. This reduction in effective condenser surface area results in a rise in condensing pressure. During summer conditions, the discharge pressure is high, thus closing the discharge port of the valve. Hence, there is full liquid flow from the condenser to the receiver.

A check valve is installed in the liquid line between the receiver and the condenser to prevent liquid migration from the receiver to the condenser during the off cycle. The low pressure control will start the condensing unit anytime the low side pressure rises above the set point and pump the refrigerant out until the pressure falls to the set point. The crankcase heater, which is energized whenever the condensing unit has power, keeps the compressor oil warmer than the coldest location in the system. This minimizes off cycle refrigerant migration. If power to the condensing unit is interrupted after the system is charged, the compressor should not be started unless the crankcase heater has been energized for at least 24 hours immediately prior to compressor startup. However the compressor can safely be started during the refrigeration system charging process (without the warm-up period) once sufficient refrigerant is in the system to maintain a positive pressure on the suction side of the compressor.

Under normal ambient operating conditions the left side condenser fan motor, when viewing the outdoor condensing unit from the compressor side, is not energized; therefore, the fan will pinwheel. During hot summer days, at elevated temperatures, the left side condenser fan will be energized to maintain the BTU efficiency of the condensing unit.

For additional information, please reference Horizon ice machine installation instructions for remote condensing units.

## Refrigerant pressure data

Air-cooled condensers (air)	60 F/16 C	70 F/21 C	80 F/27 C	90 F/32 C	100 F/38 C
Pressure (psig) discharge/suction	229/32	232/32	244/33	252/35	253/36

## Refrigerant charges

R404A ice machine charge specifications		
Model	Line Run	Charge
1400	0 – 50 ft (0 – 15.2 m)	11 lb (4.9 kg)
	50 – 75 ft (15.2 – 22.9 m)	12 lb (5.4 kg)
	75 – 100 ft (22.9 – 30.5 m)	13 lb (5.9 kg)
	100 ft+ (30.5 m+)	Consult factory

# Refrigeration system diagram

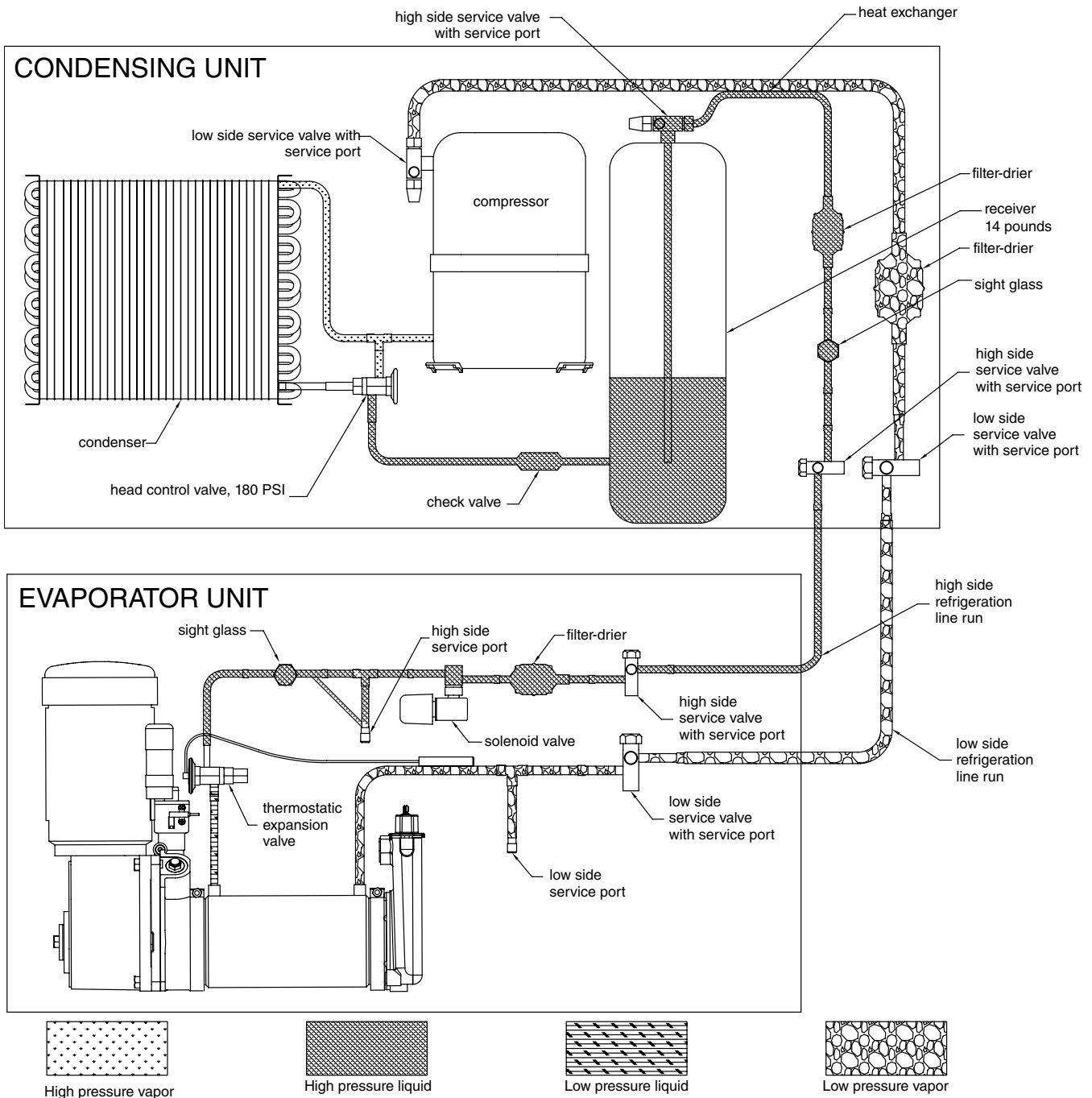



## Refrigerant replacement requirements

1. Non-contaminated refrigerant removed from any Follett refrigeration system can be recycled and returned to the same system after completing repairs. Recycled refrigerant must be stored in a clean, approved storage container. If additional refrigerant is required, virgin or reclaimed refrigerant that meets ARI standard 700-88 must be used.
2. In the event of system contamination (for example, a compressor burn out, refrigerant leak, presence of non-condensibles or moisture), the system must be repaired, evacuated and recharged using virgin or reclaimed refrigerant that meets ARI standard 700-88.
3. Follett Corporation does not approve of recovered refrigerants. Improper refrigeration servicing procedures will void the factory warranty.

## Evacuation

Evacuate the system to a level of 500 microns. When the 500 micron level is reached, close valves and both manifold and shut down the vacuum pump. Allow the system to sit for approximately 20 minutes. During this period the system pressure should not rise. If the system pressure rises and stabilizes there is moisture in the system and further evacuation is needed. If the pressure continues to rise check the system for leaks.

<b>Ambients (evaporator unit)</b>	<b>Minimum</b>	<b>Maximum</b>
Air temperature <sup>1</sup>	50 F/10 C	100 F/37.8 C
Water temperature <sup>2</sup>	45 F/7 C	90 F/32.2 C

<sup>1</sup>Ambient air temperature is measured at the air-cooled condenser coil inlet.

<sup>2</sup>Ambient water temperature is measured in the ice machine float reservoir.

## Ice capacity test

Ice machine production capacity can only be determined by weighing ice produced in a specific time period.

1. Replace all panels on ice machine.
2. Run ice machine for at least 15 minutes.
3. Weigh and record weight of container used to catch ice.
4. Catch ice for 15 or 20 minutes.
5. Weigh harvested ice and record total weight.
6. Subtract weight of container from total weight.
7. Convert fractions of pounds to decimal equivalents (ex. 6 lb 8 oz = 6.5 lb).
8. Calculate production using following formula:

$$\frac{1440 \text{ min.} \times \text{wt. of ice produced}}{\text{Total test time in minutes}} = \text{Production capacity/24 hr.}$$

9. Calculated amount per 24 hours should be checked against rated capacity for same ambient and water temperatures in Ice Production Tables.

## “Bin full” detection system

The Follett Horizon ice machine incorporates a unique “bin full” detection system, that consists of the shuttle and actuator. The shuttle incorporates a flag and sensor. Referencing the figure below, the normal running position of the flag is down, out of the sensor. When the bin fills to the top and ice can no longer move through the tube, the machine will force the shuttle flag up into the sensor, shutting the machine off. The shuttle actuator, located above the ice bin allows the ice to curl up within it when the bin is full to contain any forces. In this way, there are no loads generated that would tend to lift off the lid of the bin.

### Shuttle flag and sensor

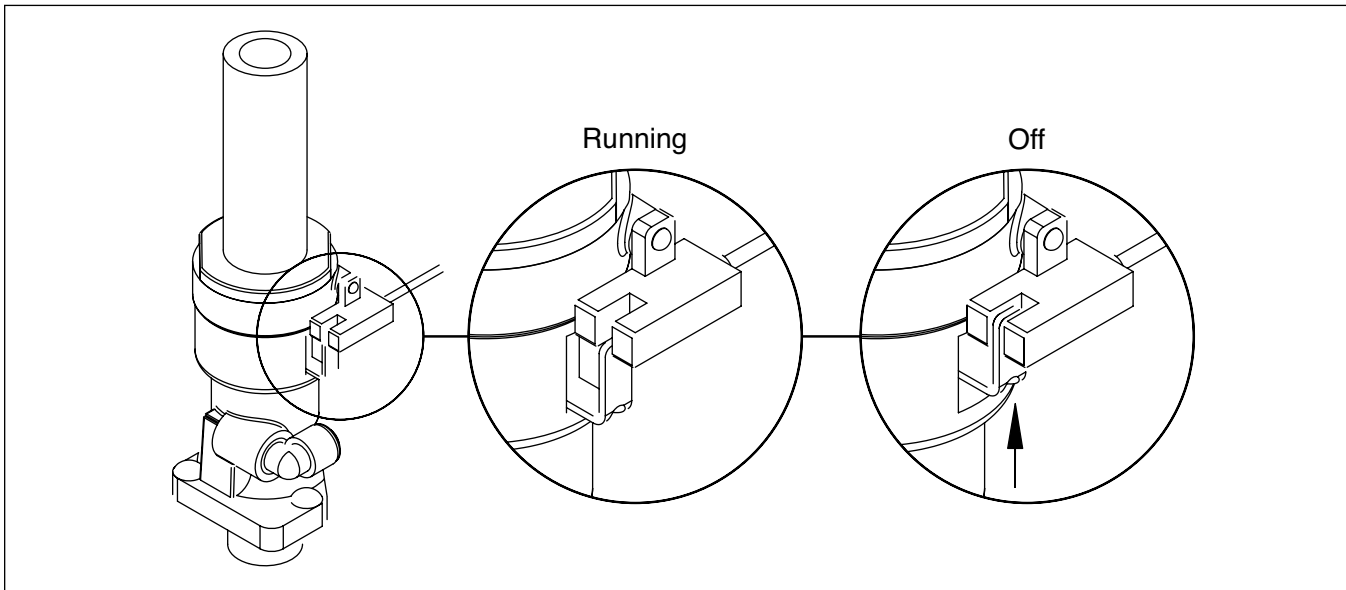

### Shuttle actuator

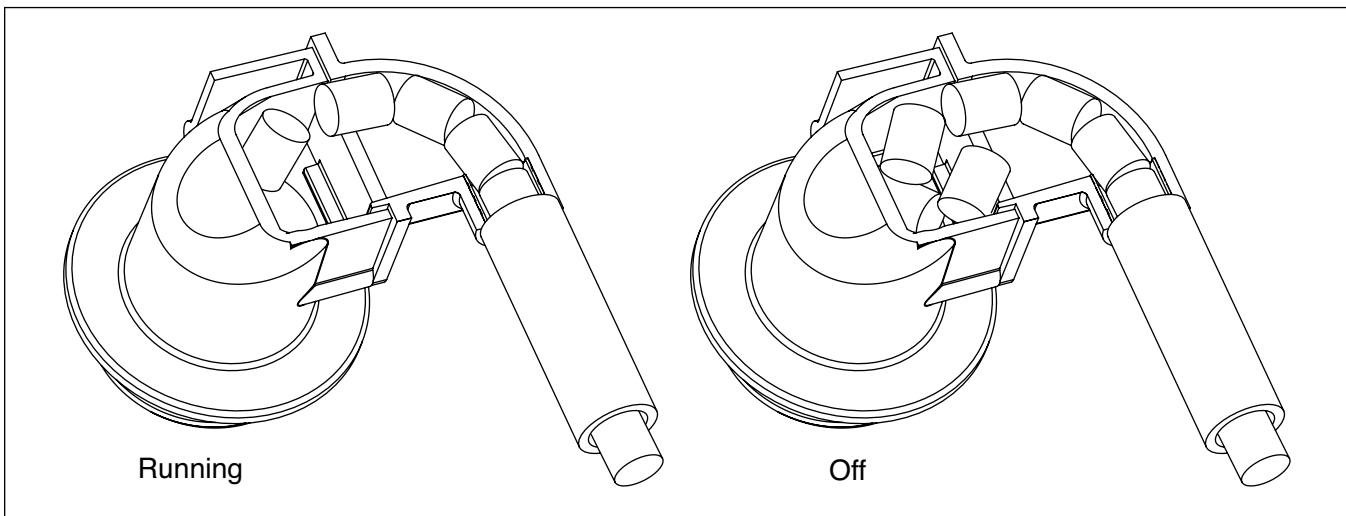

# Troubleshooting

Please see "Service" section for a description of each function.

Ice machine disposition	Possible causes	Corrective action
<b>Legend:</b> ● ON    ○ OFF    ◐ ON or OFF    ⚡ FLASHING		
1. Ice machine is in running condition but not making ice.  CPU    LO WATER    HI WATER    DRAIN CLOG ●    ○    ○    ○  HI PRESS    HI AMPS    SERVICE    PURGE    CLEANING    TIME DELAY    REFRIG ON    AUGER ON    LOW BIN    POWER ○    ○    ○    ○    ○    ○    ●    ●    ●    ●	1. Defective compressor. 2. Defective start relay. 3. Defective start capacitor. 4. Defective run capacitor. 5. Defective main contactor. 6. No output from PC board. 7. Machine in Purge cycle.	1. Replace compressor. 2. Replace start relay. 3. Replace start capacitor. 4. Replace run capacitor. 5. Replace main contactor. 6. Replace PC board. 7. Check for Purge operation.
2. Machine in TIME DELAY without full bin.  CPU    LO WATER    HI WATER    DRAIN CLOG ●    ○    ○    ○  HI PRESS    HI AMPS    SERVICE    PURGE    CLEANING    TIME DELAY    REFRIG ON    AUGER ON    LOW BIN    POWER ○    ○    ○    ○    ○    ◐    ○    ○    ○    ●	1. Ice jamming due to improperly installed transport tube causing a false shuttle. 2. Shuttle stuck in up position. 3. Damaged or improperly installed thermostat (open). 4. Transport tube backed-out of coupling.	1. Correct transport tube routing. 2. Repair or replace shuttle mechanism. 3. Replace or reposition thermostat. 4. Correct coupling installation.
3. Ice machine is not making ice. HI AMPS.  CLEANER FULL    DRAIN CLOG    HI PRESS    HI AMPS    SERVICE    MAINT/CLEAN    LOW WATER    TIME DELAY    NOT USED    MAKING ICE    LOW BIN    POWER ON ○    ○    ○    ●    ○    ○    ○    ○    ○    ○    ○    ●	1. Poor water quality causing ice to jam auger. 2. Damaged shuttle mechanism or thermostat (closed). 3. Kinked transport tube (thermostat systems). 4. Intermittent drive output from PC board. Evaporator will freeze causing a hi amps error. 5. Gearmotor is unplugged.	1. Clean ice machine. Increase flushing frequency. 2. Replace or repair shuttle mechanism/thermostat. 3. Straighten transport tube. 4. Replace PC board. 5. Plug in gearmotor.
4. Ice machine is not making ice. Drain clog.  CPU    LO WATER    HI WATER    DRAIN CLOG ●    ○    ○    ●  HI PRESS    HI AMPS    SERVICE    PURGE    CLEANING    TIME DELAY    REFRIG ON    AUGER ON    LOW BIN    POWER ○    ○    ●    ○    ○    ○    ○    ○    ○    ○    ●    ●	1. Drain hose kinked or plugged causing water to back up. 2. Improper floor drain routing/pitch causing water to back up. 3. High TDS levels and leaking drain solenoid may cause an errant drain clog.	1. Remove kink or blockage from drain hose. 2. Re-route floor drain. 3. Clean area around drain sensor and/or replace Drain solenoid valve.

Ice machine disposition	Possible causes	Corrective action
<b>Legend:</b> ● ON    ○ OFF    ◐ ON or OFF    ◑ FLASHING		
5. Ice machine is not making ice. Locked in PURGE. CPU    LO WATER    HI WATER    DRAIN CLOG ◑    ○    ○    ○ HI PRESS    HI AMPS    SERVICE    PURGE    CLEANING    TIME DELAY    REFRIG ON    AUGER ON    LOW BIN    POWER ○    ○    ○    ●    ○    ◐    ○    ○    ○    ○    ●	1. A self-flush occurred but could not drain evaporator due to a failed drain solenoid valve. 2. A self-flush occurred but could not drain evaporator due to water reservoir or ice machine not being level.	1. Replace drain solenoid valve. 2. Level ice machine. Check water reservoir to make sure it is not tilted towards the compressor.
6. The CPU is not flashing. CPU    LO WATER    HI WATER    DRAIN CLOG ◐    ○    ○    ○ HI PRESS    HI AMPS    SERVICE    PURGE    CLEANING    TIME DELAY    REFRIG ON    AUGER ON    LOW BIN    POWER ○    ○    ○    ○    ○    ○    ○    ○    ○    ○    ○	1. Processor has been damaged.	1. Replace PC board.
7. Ice machine is making ice. Excessive water in bin or coming into bin from transport tube. CPU    LO WATER    HI WATER    DRAIN CLOG ◑    ○    ○    ○ HI PRESS    HI AMPS    SERVICE    PURGE    CLEANING    TIME DELAY    REFRIG ON    AUGER ON    LOW BIN    POWER ○    ○    ○    ○    ○    ○    ●    ●    ●    ●	1. Failed water sensors. Processor assumes there is no water when there is water. 2. Blocked reservoir vent. 3. Defective water feed solenoid valve. Stuck in open position.	1. Clean or replace water probe assembly. Check wiring connections. 2. Clean or replace vent tubes. 3. Replace water feed solenoid valve.
8. Ice machine is not making ice. Lo water. CPU    LO WATER    HI WATER    DRAIN CLOG ◑    ●    ○    ○ HI PRESS    HI AMPS    SERVICE    PURGE    CLEANING    TIME DELAY    REFRIG ON    AUGER ON    LOW BIN    POWER ○    ○    ●    ○    ○    ○    ○    ○    ○    ○    ●	1. Water supply is turned off. 2. Low water pressure. 3. Defective water feed solenoid valve. Stuck in closed position. 4. No water feed output from PC board.	1. Turn water supply on. If evaporator was completely empty the reset button may have to be pressed to restart the ice machine. 2. Ice machine will eventually start when water reaches normal lo level. 3. Replace water feed solenoid valve. 4. Replace PC board.



# Replacement parts

Order parts online  
[www.follettice.com](http://www.follettice.com)

## Evaporator assembly

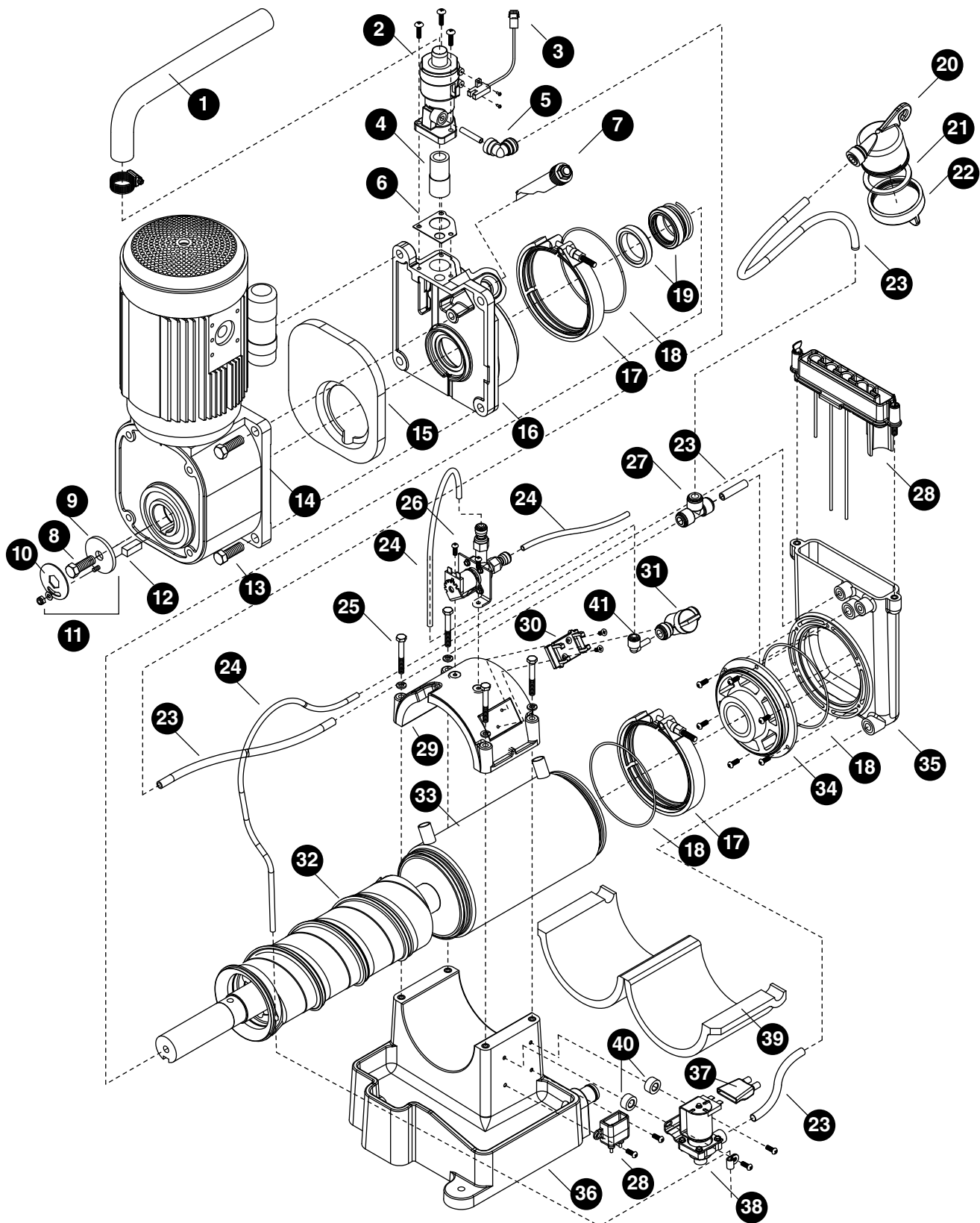

Reference #	Description	Part #
1	Tube, ice transport, molded	00175299
2	Shuttle assembly (includes gasket and nozzle)	00130815
3	Switch, optical	00130849
4	Compression nozzle	00115774
5	Elbow, water	00134502
6	Gasket, shuttle	00115600
7	Stream divider	00142521
8	Auger bolt	00116988
9	Washer	00161513
10	Retainer, auger bolt	00161356
11	Kit, auger bolt (auger bolt, washer, retainer, nut and washer)	00161406
12	Key	00117804
13	Bolts, gearmotor mounting (4) required	00130641
14	Gearmotor, 120 V (includes capacitor)	00130799
15	Gasket, gearmotor	00121632
16	Main housing (includes auger shaft seal and O ring)	00142539
17	Coupling, V-band	00130708
18	O ring	00116962
19	Seal, auger shaft	00112946
20	Cup, sanitizer	00130674
21	Gasket, sanitizer	00124032
22	Cap, sanitizer (includes gasket)	00130880
23	Tubing, water, 3/8" OD (per foot)	502719
24	Tubing, water, 1/4" OD	502079
25	Hardware, mounting, evaporator cap	00130989
26	Solenoid, water feed (120V)	00130823
27	Tee, water	00134494
28	Sensor assembly, water level and drain clog	00171363
29	Cap, evaporator (includes insulation and mounting hardware)	00130740
30	Clip, water shut-off valve	502922
31	Valve, shut-off, water	502921
32	Auger (includes seal & O ring)	00945725
33	Evaporator (includes seal, (2) O rings and insulation)	00137570
34	Journal housing and bearing (includes (2) O rings)	00130716
35	Reservoir, water	00130690
36	Base, evaporator	00130732
37	Boot, solenoid	00160309
38	Solenoid, purge (120 V)	00130757
39	Insulation, evaporator	00133876
40	Spacers, solenoid	00160317
41	Elbow, 1/4" tube x 3/8" stem	00988030
Not shown	Insulation, evaporator cap	00125468
Not shown	Condensate pan	00161612
Not shown	Shuttle assembly, Micro Chewblet (includes gasket and nozzle)	00985028
Not shown	Pan, gearbox condensate (includes silicone)	01051796

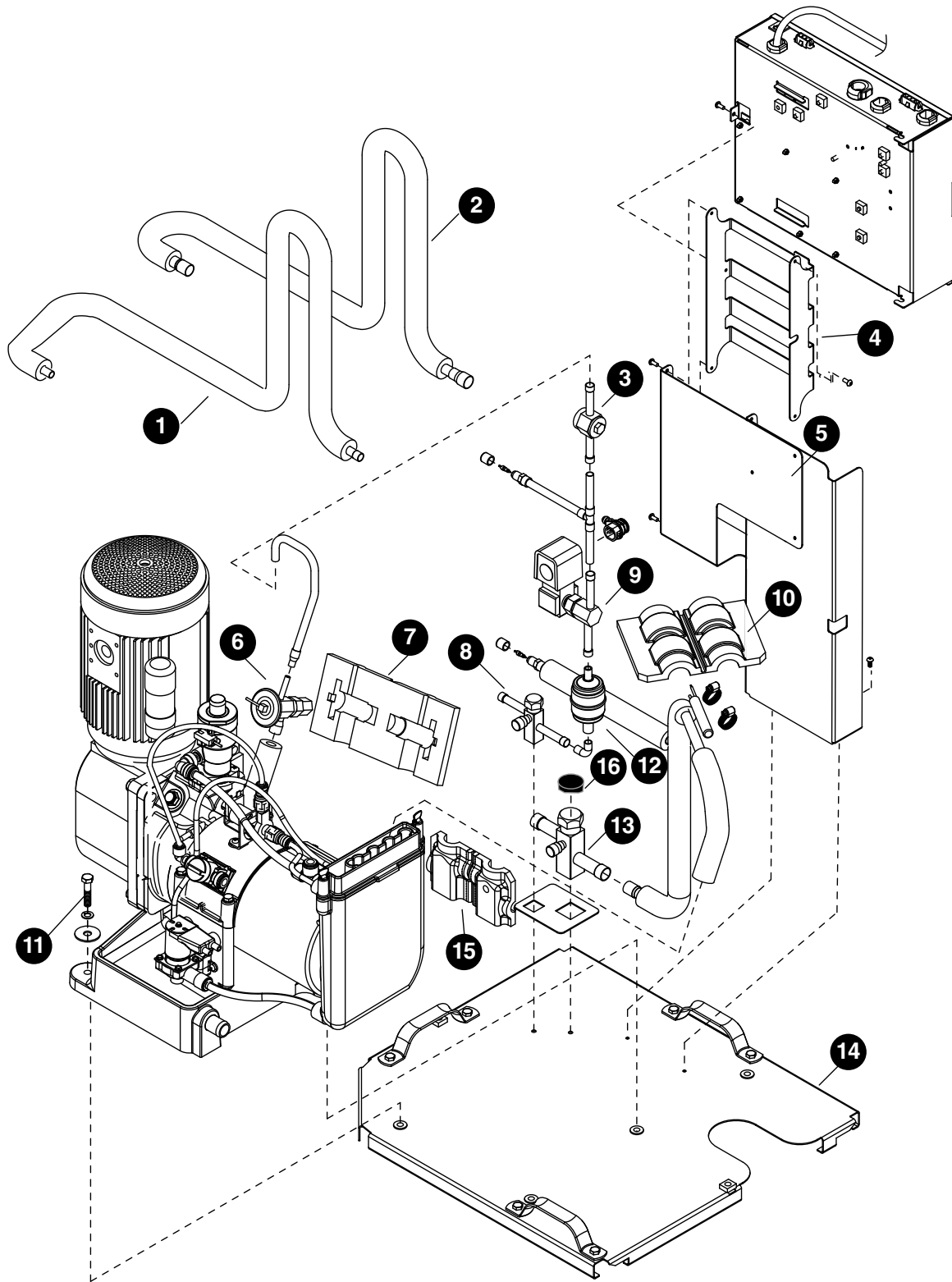



<b>Reference #</b>	<b>Description</b>	<b>Part #</b>
1	Tubing, liquid line (includes insulation)	00142414
2	Tubing, suction line (includes insulation)	00131045
3	Sight glass	00107045
4	Electrical box support	00153635
5	Split system support bracket assembly	01051762
6	Valve, expansion, thermal (includes TXV insulation and bulb insulation)	00136317
7	Insulation, TXV	502830
8	Valve, shut-off, liquid line	00107060
9	Valve, solenoid	00107052
10	Insulation, bulb, TXV	00106534
11	Hardware, evaporator mounting base (set of four)	00130971
12	Dryer	00134593
13	Valve, shut-off, suction line	00107078
14	Base, split system	00130864
15	Insulation, service valve	00168914
16	Cap, valve, shut-off, suction line	00991026

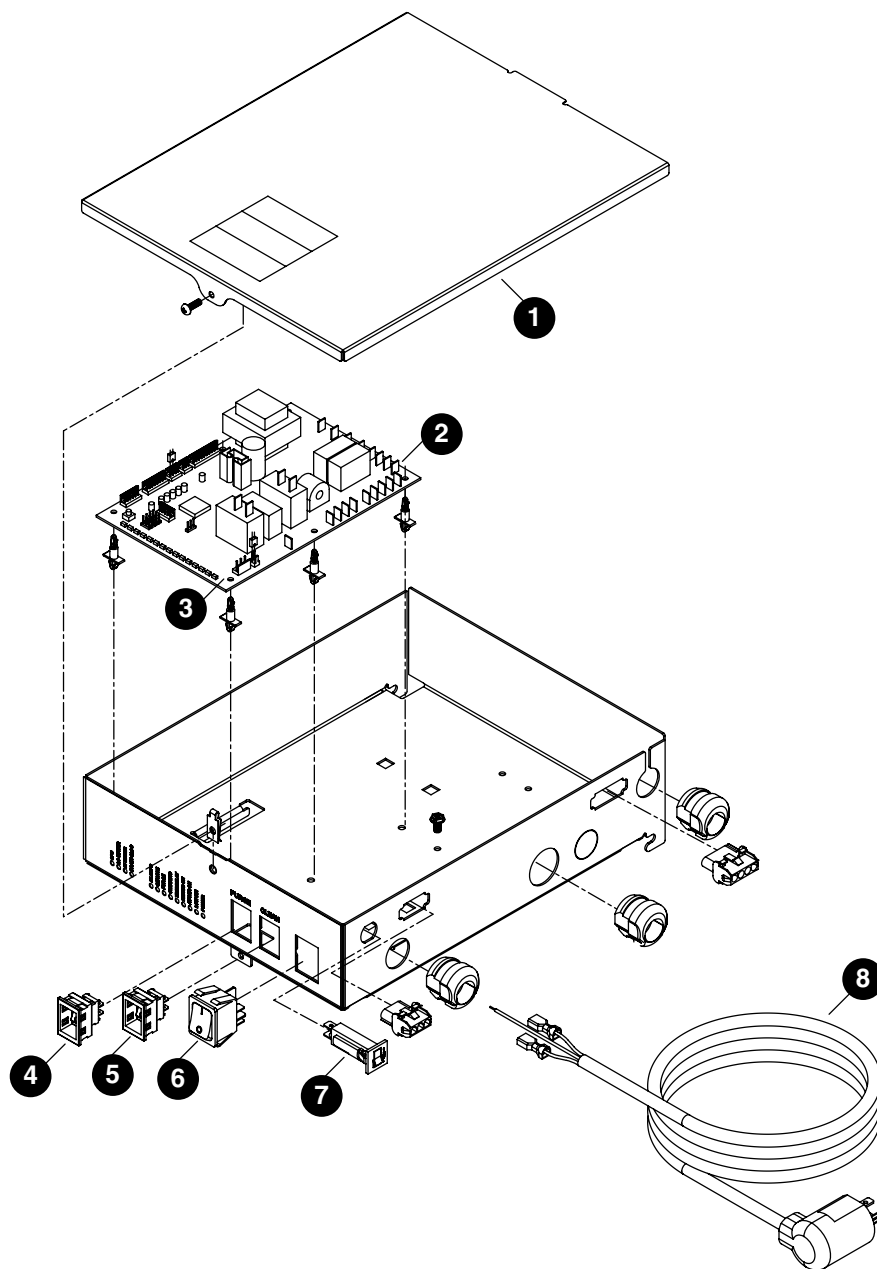

Reference #	Description	Part #
1	Cover, electrical box, remote	00130898
2	Board, control circuit, 120V (includes standoffs)	00132910
3	Stand off's (set of 6)	00130906
4	Switch, evaporator purge	00114371
5	Switch, evaporator clean	00117036
6	Switch, ice machine power	208867
7	Circuit breaker, 8A	00128090
8	Cord, power	00192088

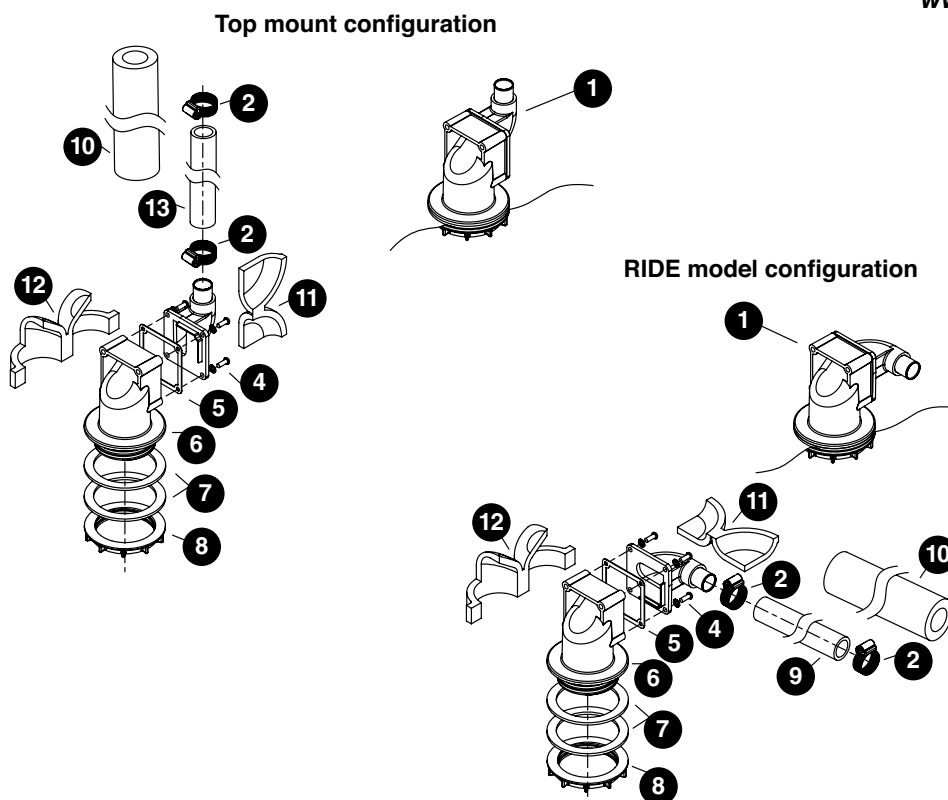

Reference #	Description	Part #
1	Shuttle actuator	00171322
2	Clamp	500377
3	Actuator elbow (includes gasket and screws)	00171264
4	Screws	209100
5	Gasket	00167122
6	Actuator body	00171272
7	Gasket, coupling	00126532
8	Ring, locking (includes coupling gasket)	00171371
9	Ice transport tube, 10' (3 m)	00171280
9	Ice transport tube, 20' (6 m)	00171298
10	Insulation, transport tube	501176
Not shown	Insulated polywire ice transport tube, per foot	00174896
11	Insulation, elbow	00168922
12	Insulation, actuator	00168930
13	Ice transport tube, top mount, 30" (762 mm)	00171306
Not shown	Integration kit, top mount	00171389
Not shown	Integration kit, RIDE model (includes 10' (3m) of tube and insulation)	00171397
Not shown	Extension-fill tube, 9"	00135723
Not shown	Extension-fill tube, 4"	00153684
Not shown	Diverter plate (single agitator Cornelius dispensers and left-hand dispense chute on dual-agitator Cornelius dispensers)	307277
Not shown	Diverter plate (right-hand dispense chute on dual-agitator dispensers)	00996207
Not shown	Follett SafeCLEAN ice machine cleaner (case of 24 x 7 oz packets)	00132001
Not shown	Sani-Sponge kit	00132068

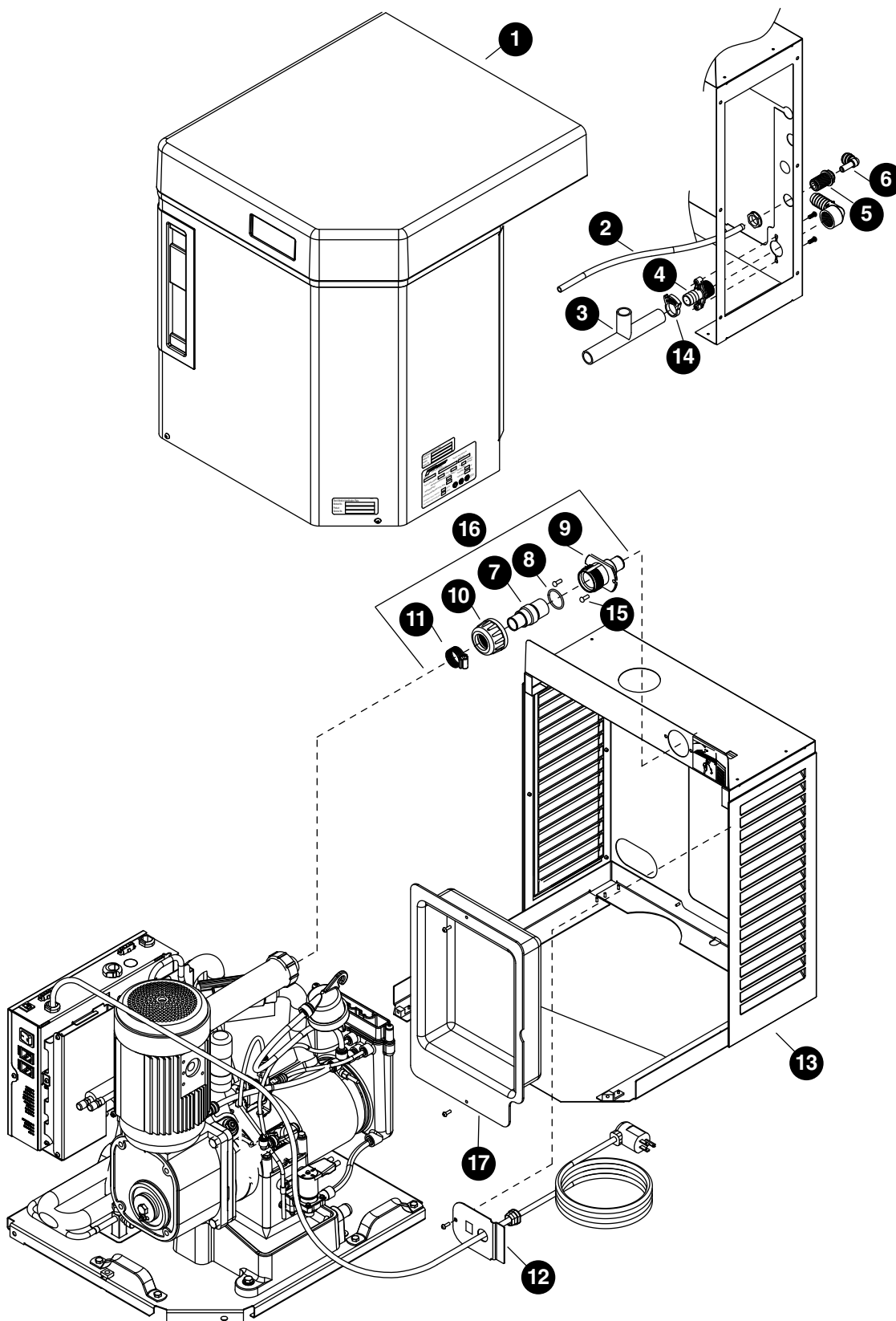

Reference #	Description	Part #
1	Front cover, split system	00130633
2	Tubing, water, 3/8" OD	502719
3	Tubing, drain	00144923
4	Fitting, drain	00109728
5	Fitting, water inlet	502924
6	Elbow, water inlet	502925
7	Coupling (includes O ring)	00171207
8	O ring	00144675
9	Bulkhead fitting	00171215
10	Nut	00902338
11	Hose clamp	500377
12	Plate, strain relief	00192070
13	Louvered docking assembly, split system (includes reference #'s 2, 3, 4, 5, 6, 9, 12, 14, 15, 17)	00191882
14	Clamp, drain line	00114520
15	Screws	208568
16	Bulkhead connector kit	00171223
17	Cover, utility access	01017987

**Top View**

**Side View**

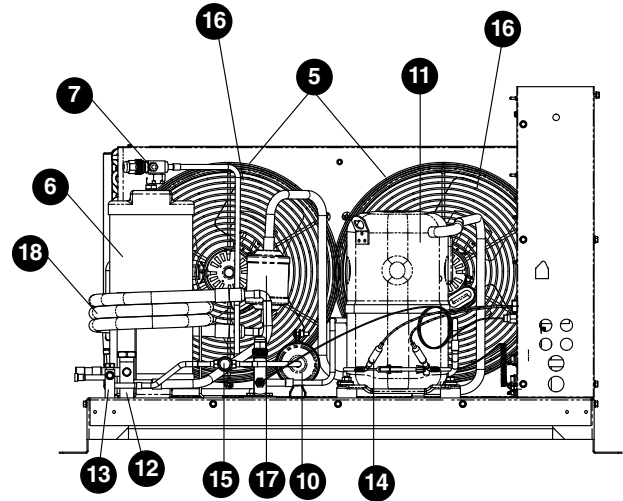
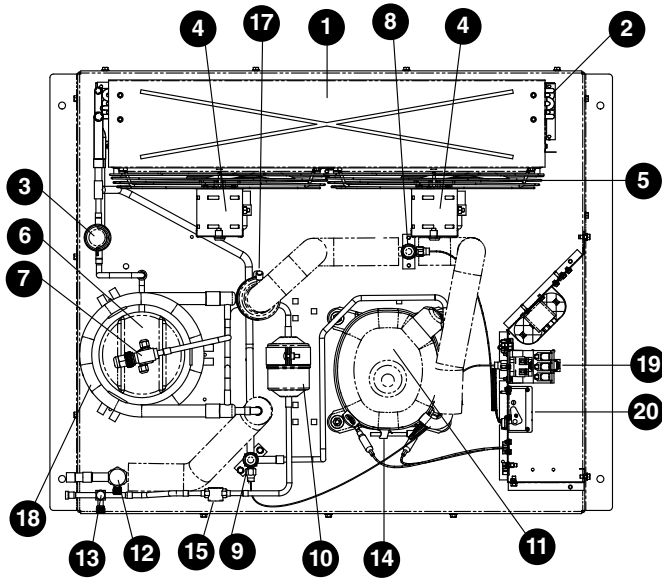

Reference #	Description	Part #
1	Shroud	00155937
2	Condenser	00185843
3	Head pressure control valve	00110619
4	Condenser fan motor	00173070
5	Condenser fan guard	00123067
6	Receiver	00110627
7	Receiver service valve	00173047
8	Service valve, suction line	00185835
9	Service valve, discharge line	00175935
10	Filter drier, liquid	00175869
11	Compressor (includes crankcase heater, start components, check valve and filter driers)	01078864
11	Retrofit compressor (includes receiver heater, check valve, crankcase heater and filter driers)	01077007
12	Shut-off valve, suction line	00107078
13	Shut-off valve, liquid line	00107060
14	Crankcase heater	00185827
15	Sight glass	00175885
16	Condenser fan blade	00173088
17	Filter drier, suction	00991075
18	Heat exchanger	00185850
19	Contactors	00155952
20	Low pressure switch	00173104
Not shown	Check valve	00175893
Not shown	Starting relay	00110585
Not shown	Gasket, receiver service valve	00175901
Not shown	Baffle, shroud	00173096
Not shown	Run capacitor	00141689
Not shown	Starting capacitor	00185793
Not shown	High pressure switch	00173112
Not shown	Fan cycling switch	00173120

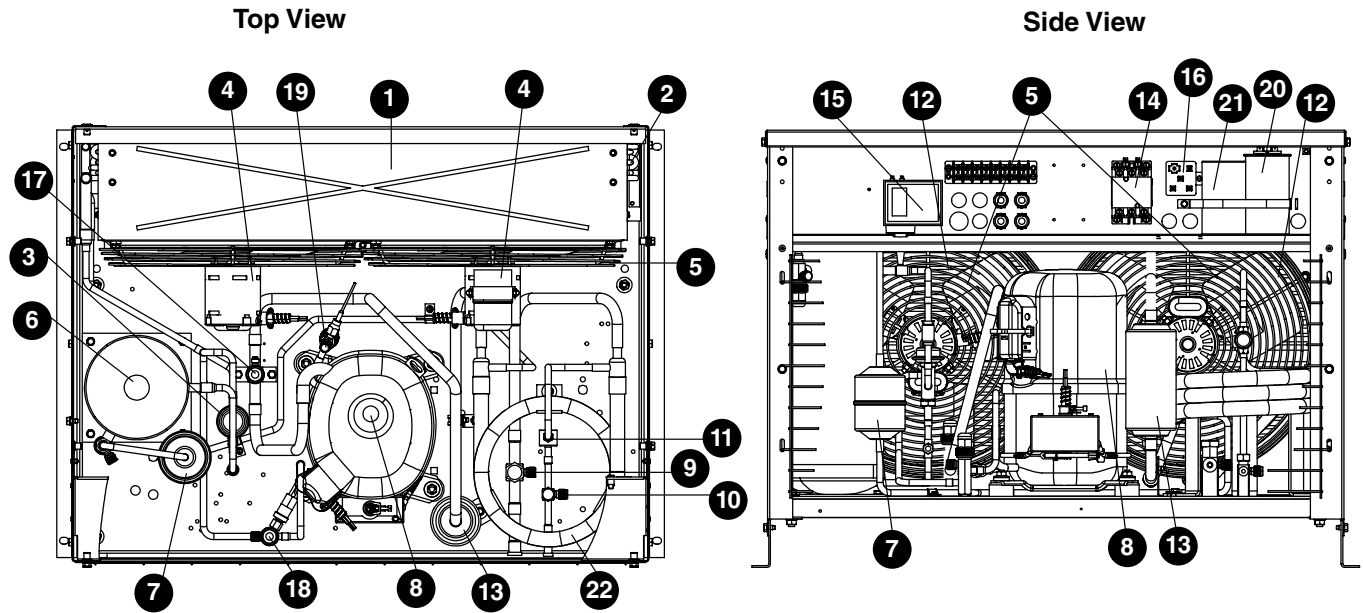

Reference #	Description	Part #
1	Shroud	01018290
2	Condenser	00185843
3	Head pressure control valve	01021401
4	Condenser fan motor	01018266
5	Condenser fan guard	00123067
6	Receiver	00991034
7	Filter drier, liquid	00998245
8	Compressor (includes crankcase heater, start components, check valve and filter driers)	01078864
8	Retrofit compressor (includes receiver heater, check valve, crankcase heater and filter driers)	01077015
9	Shut-off valve, suction line	00107078
10	Shut-off valve, liquid line	00107060
11	Sight glass	01018357
12	Condenser fan blade	00173088
13	Filter drier, suction	00991075
14	Contactors	00155952
15	Low pressure control	01018316
16	Starting relay	00110585
17	Suction valve	00185835
18	Discharge valve	01021435
19	Process valve	01036821
20	Run capacitor	00141689
21	Starting capacitor	01036755
22	Heat exchanger	00185850
Not shown	Check valve	00175893
Not shown	High pressure switch	01018308
Not shown	Fan cycling switch	01021393
Not shown	Crankcase heater	00185827

**Note:** Overload is internal to compressor.

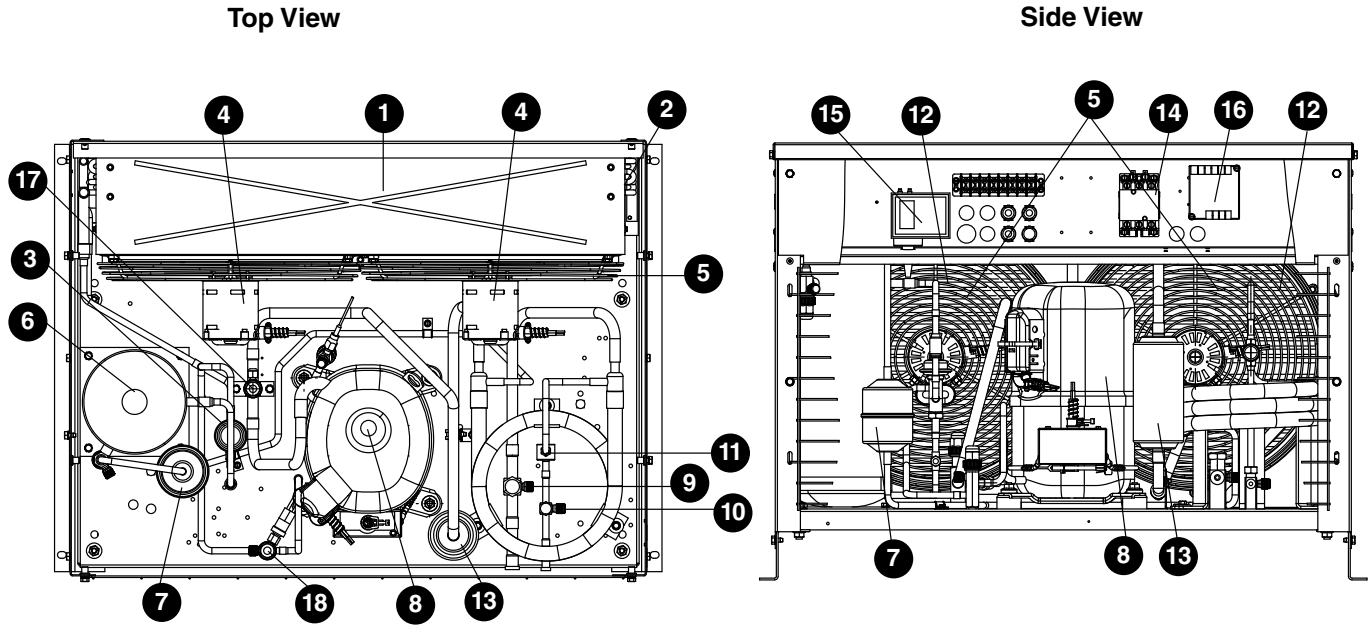

Reference #	Description	Part #
1	Shroud	01018290
2	Condenser	00185843
3	Head pressure control valve	00110619
4	Condenser fan motor	01018266
5	Condenser fan guard	00123067
6	Receiver	00991034
7	Filter drier, liquid	00998245
8	Compressor (includes crankcase heater, check valve and filter driers)	01078872
8	Retrofit compressor (includes crankcase heater, receiver heater and filter driers)	01077023
9	Shut-off valve, suction line	00107078
10	Shut-off valve, liquid line	00107060
11	Sight glass	00175885
12	Condenser fan blade	00173088
13	Filter drier, suction	00991075
14	Contactors	00155952
15	Low pressure control	01018316
16	Phase monitor	00991117
17	Suction valve	00185835
18	Discharge valve	01021435
Not shown	Check valve	00175893
Not shown	High pressure switch	00173112
Not shown	Fan cycling switch	00173120

Harmony, Ice Manager, SafeCLEAN, Sani-Sponge and Vision are trademarks of Follett Products, LLC. Chewblet, RIDE and Follett are registered trademarks of Follett Products, LLC, registered in the US.



801 Church Lane • Easton, PA 18040, USA  
Toll free (877) 612-50861 • +1 (610) 252-7301  
www.follettice.com

01034701R06  
© Follett Products, LLC7/22