

# T400A/W, MCD400A/W, R400A/W, MFD400A/W, D400A/W Ice Machines

Installation, Operation and Service Manual  
Serial numbers above D25455

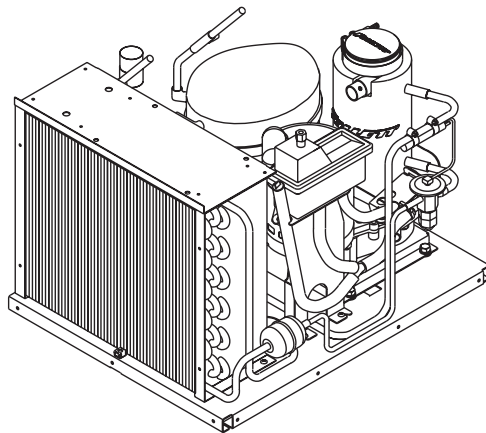

**Following installation, please forward this manual  
to the appropriate operations person.**

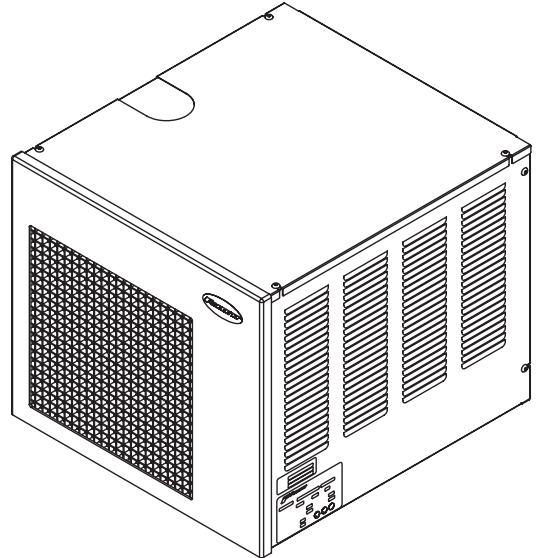
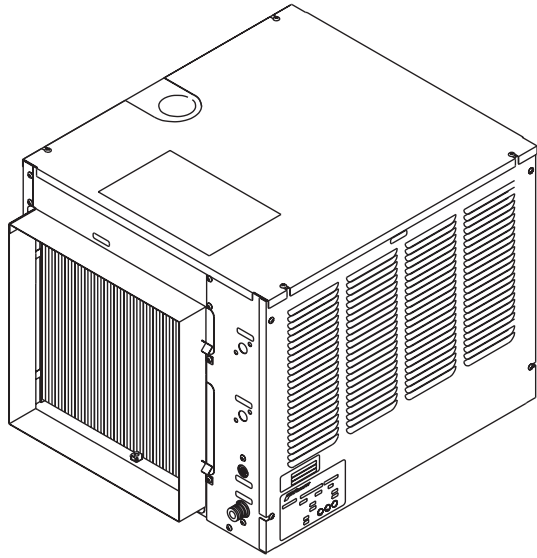

# Table of contents

<b>Welcome to Follett Corporation</b> .....	<b>4</b>
<b>Specifications</b> .....	<b>5</b>
<b>Installation</b> .....	<b>8</b>
Top mount ice machines (models T400A/W, MCD400A/W and MFD400A/W) .....	8
RIDE® model ice machines (models MCD400A/W, R400A/W).....	9
Ventilation.....	14
Ice transport tube .....	15
Start up.....	17
<b>Cleaning/descaling and sanitizing</b> .....	<b>17</b>
Weekly.....	17
Monthly.....	18
Semi-annually.....	18
<b>Service</b> .....	<b>19</b>
Ice machine operation.....	19
Technical specifications.....	20
Refrigeration system diagram.....	20
Refrigeration pressure data .....	20
Compressor data .....	20
Gearmotor data .....	21
MCD400A/W wiring diagram .....	21
Electrical control system operation.....	22
Refrigeration system .....	28
Service procedures .....	29
Evaporator disassembly .....	29
Evaporator reassembly.....	29
Gearmotor replacement .....	29
<b>Troubleshooting</b> .....	<b>30</b>
<b>Replacement parts</b> .....	<b>32</b>

## Welcome to Follett

Follett equipment enjoys a well-deserved reputation for excellent performance, long-term reliability and outstanding after-the-sale support. To ensure that this equipment delivers that same degree of service, we ask that you review the installation portion of this manual before beginning to install the unit. Our instructions are designed to help you achieve a trouble-free installation. Should you have any questions or require technical help at any time, please call our technical service group at (877) 612-5086 or +1 (610) 252-7301.

**Note:** To expedite assistance, all correspondence or communication **MUST** include the model number, serial number and complete and detailed explanation of the problem.

## Before you begin

After uncrating and removing all packing material, inspect the equipment for concealed shipping damage. If damage is found, notify the shipper immediately and contact Follett Corporation so that we can help in the filing of a claim, if necessary.

Check your paperwork to determine which model you have. Follett model numbers are designed to provide information about the type and capacity of Follett equipment. Following is an explanation of the different model numbers in the 400 series.

# MCD400ABT

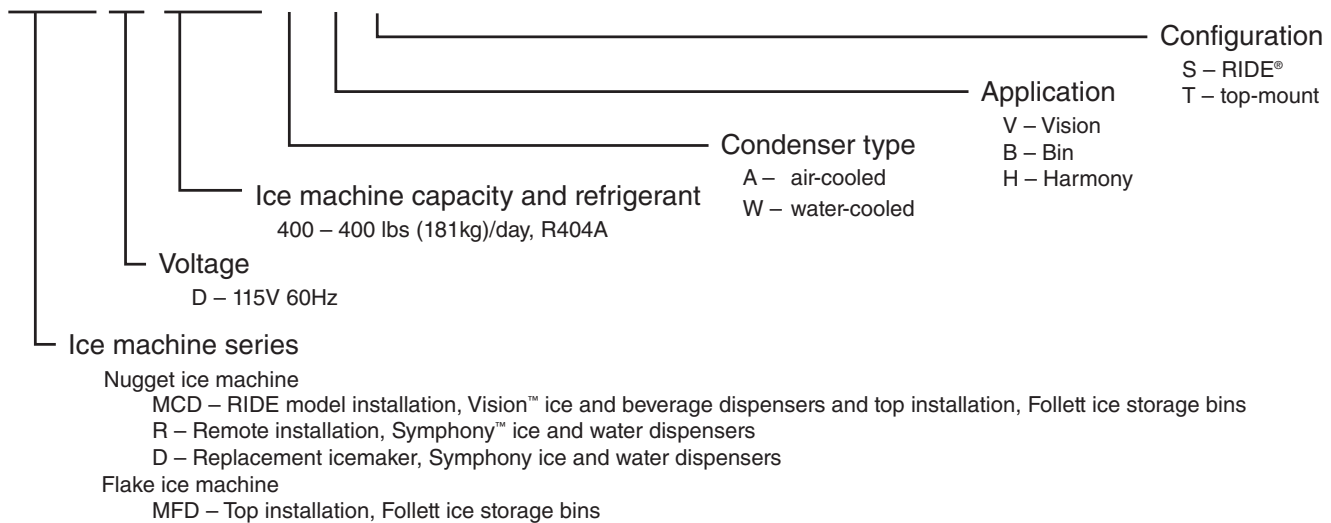

### Important cautions

Moving parts. Do not operate with front cover removed.

Hot parts. Do not operate with cover removed.

To reduce risk of shock disconnect power before servicing.

Most ice machine cleaners contain citric or phosphoric acid, which can cause skin irritation. Read caution label on product and follow instructions carefully.

Ice is slippery. Maintain counters and floors around dispenser in a clean and ice-free condition.

Ice is food. Follow recommended cleaning instructions to maintain cleanliness of delivered ice.

# Specifications

## Electrical

- Each ice machine and dispenser require a separate circuit with electrical disconnect within 10 ft (6m).
- Equipment ground required.
- Standard electrical – 115 V, 60 Hz, 1 phase.
- Maximum dispenser fuse – 15A,
- Maximum ice machine fuse – 20A each
- Maximum ice machine amperage – 11A each
- Cord and plug provided on ice machine and dispenser

## Electrical connections

Model	Electrical connection	Circuits required
25FB400A/W, 50FB400A/W, 110FB400A/W	cord & plug provided	115/60/1, 20A max. fuse size
25CT400A/W, 50CT400A/W, 110CT400A/W	cord & plug provided	115/60/1, 20A max. fuse size
25CR400A/W, 50CR400A/W, 110CR400A/W	dispenser, ice machine and bin signal: cord & plug provided	115/60/1, (2) circuits required dispenser: 15A max. fuse size ice machine: 20A max. fuse size
VU155R400A/W, VU300R400A/W VU155BR400A/W, VU300BR400A/W VU155R400A/WX, VU155BR400A/WX	dispenser, ice machine and bin signal: cord & plug provided	115/60/1, (2) circuits required dispenser: 15A max. fuse size ice machine: 20A max. fuse size
VU155NR400A/W, UD300R400A/W VU155R800A/W, VU300R800A/W, VU155R800A/WX, VU155BR800A/W, VU300BR800A/W, VU155R800A/WX	dispenser, ice machine and bin signal: cord & plug provided	115/60/1, (3) circuits required dispenser: 15A max. fuse size ice machine: 20A max. fuse size

### CAUTION!

- Check start relay before supplying power.
- Start relay is gravity sensitive and MUST be in "up" position.
- Failure to comply may cause equipment to overheat, resulting in equipment failure, equipment damage or a fire hazard.

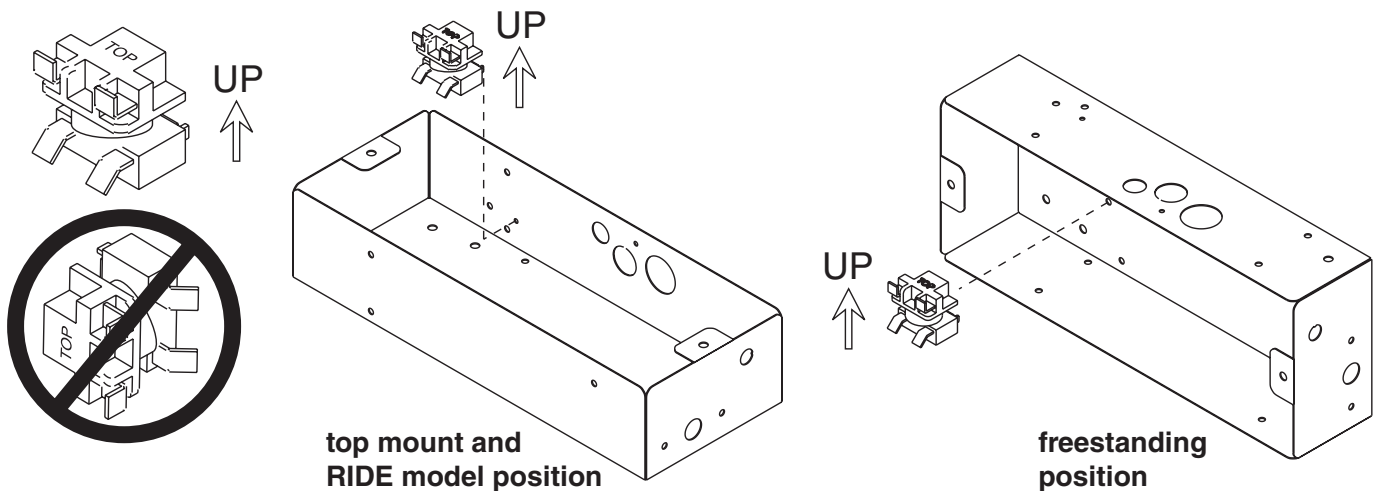

## Plumbing

- 3/8" OD push-in water inlet
- 3/4" MPT drain
- 3/8" FPT condenser inlet (water-cooled condenser only – 1.25 gpm minimum available flow)
- 3/8" FPT condenser drain (water-cooled condenser only)

## Notes:

- Slope to drain of 1/4" per foot (6 mm per 30.4 cm run) with a 1/2" min. is recommended.
- Water shut-off recommended within 10 feet (3 m), drain to be hard piped and insulated.
- Separate drains for ice machine and condenser. To prevent back flow, do NOT connect drains.
- Follett recommends a Follett water filter system be installed in the ice machine inlet water line (standard capacity #00130299, high capacity #00978957, carbonless high capacity #01050442).

## Ambient

Air temperature	100 F/38 C max.	50 F/10 C min. (best performance below 80 F/27 C)
Water temperature	90 F/32 C max.	40°F/4°C min. (best performance below 70 F/21 C)
Water pressure	70 P.S.I max. (482 kPA)	10 P.S.I. min. (89 kPA)

## Dimensions and clearances

- Entire front of ice machine must be clear of obstructions/connections to allow removal.
- 12" (30.5 cm) clearance above ice machine for service.
- 6" (15.3 cm) minimum clearance between exhaust side of ice machine and any adjacent equipment.
- MCD400A & R400A – 18" (45.7 cm) minimum, 10 ft (3 m) maximum clearance between discharge and air intake grilles.

Front view — air-cooled  
top mount

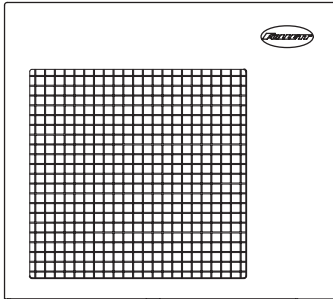

Back view — air-cooled  
top mount

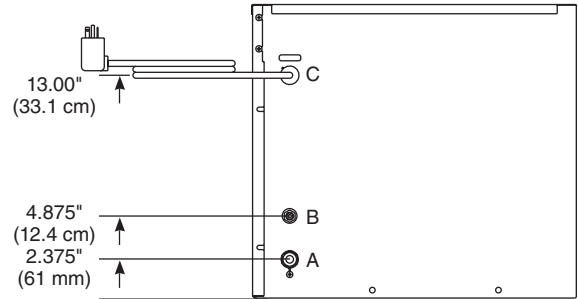

Front view — air-cooled  
RIDE model

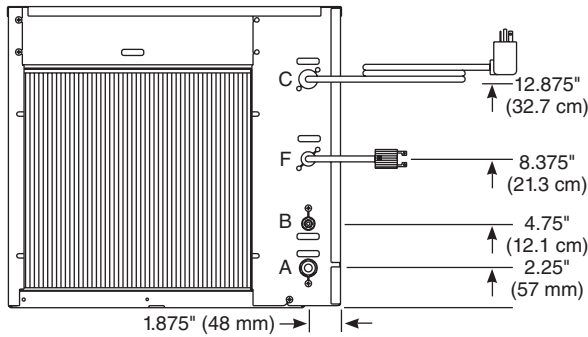

Front view — water-cooled  
RIDE model

Back view — water-cooled  
top mount

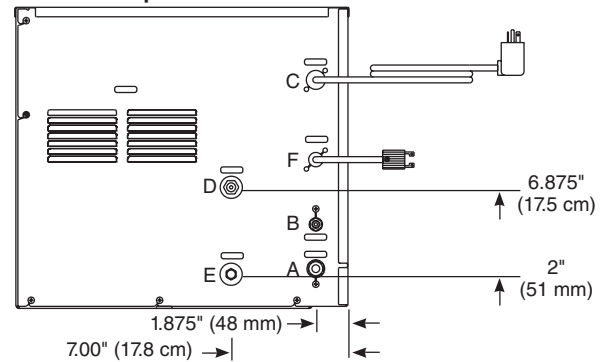

Side view — air-cooled and water-cooled  
top mount and RIDE model

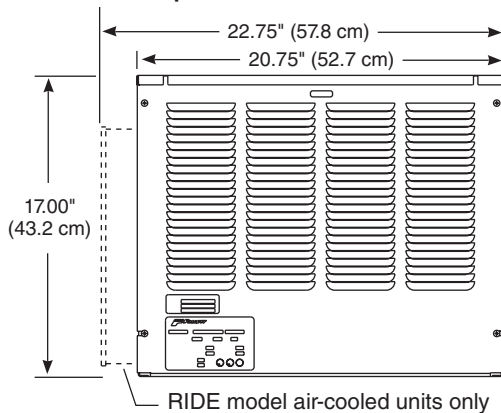

Ice machine plug  
configuration  
NEMA 5-20



- |  |                                     |
|--|-------------------------------------|
| <b>A</b> – 3/4" MPT drain              | <b>D</b> – 3/8" FPT condenser inlet |
| <b>B</b> – 3/8" OD push-in water inlet | <b>E</b> – 3/8" FPT condenser drain |
| <b>C</b> – Electrical cord             | <b>F</b> – Bin signal cord          |

## Installation

Ice machine performance is very sensitive to the quality of installation. To ensure proper performance, ease of service and warranty coverage, it is critical that you follow the requirements detailed in this manual. If you cannot meet these requirements or have questions, call our technical service group immediately at (877) 612-5086 or +1 (610) 252-7301.

### Top mount ice machine on bin installation procedure (models MCD400A/WBT and MFD400A/WBT)

#### Install ice machine and rough-in utilities

1. Install ice storage bin in its final location.
2. Install one supplied grommet in large knockout in base of ice machine and second supplied grommet in ice hole provided in top of ice storage bin.
3. Rough in plumbing and electrical per specifications provided.
4. Flush all water lines before final hook up.
5. Position ice machine with utility connections facing rear of bin.
  - If new storage bin and ice machine – position ice machine with connections facing rear of bin.
  - If using existing bin – place supplied gasket 2.5" (64 mm) from front of bin (**Fig. 1**). Position ice machine with utility connections facing rear of bin.

Fig. 1

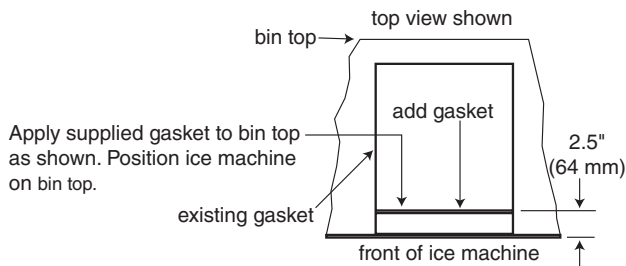

6. Make final plumbing and electrical connections.
7. Working from inside bin storage area, push end of transport tube without fasteners up through grommets into ice machine, leaving about 2" (51 mm) hanging down in bin.
8. Route free end of tube to evaporator port.
9. Slip a hose clamp in free end of tube.
10. Push free end of tube on evaporator port and tighten clamp, making sure clamp is positioned on evaporator side of flange (no flange on MFD400 series flake ice machine).
11. Position ice tube under float bracket retaining tab.
12. Carefully slip ice level control stat alongside transport tube through both grommets and down into bin.
13. Run ice level control stat down through one side of cap tube fasteners attached to ice transport tube, form a 180° bend at end of tube and run back up through fastener (**Fig. 2**).

Fig. 2

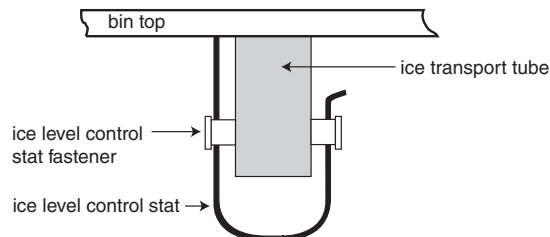

14. Adjust loop length to provide desired ice level. Loop must be below end of ice transport tube.
15. Carefully bend end of cap tube to prevent it from slipping out of clamp.

#### Before turning power on

1. Clean and sanitize ice storage bin in accordance with cleaning procedure in ice storage bin installation information packed with ice storage bin.



2. Turn water to ice machine on.
3. Remove cover on float reservoir.
4. Push down on float to force water out overflow tube and into evaporator drain pan.
5. Check that water drains freely from evaporator drain pan.
6. Lift float and check that float valve shuts off incoming water when raised.

#### After turning power on

1. Turn power to ice machine on and confirm that gearmotor, compressor and fan motor start immediately.
2. Check that ice begins to enter bin within approximately 10 minutes.
3. With ice machine running, check that float reservoir water level is approximately 3/8" (10mm) below internal overflow and adjust to this level (raised line on side of reservoir) if necessary.
4. After making ice for 10 minutes, put ice against ice level control stat cap tube and check that ice machine shuts down.
5. Warm ice level control stat with your fingers and check that ice machine restarts in approximately 20 minutes. (Bin must be calling for ice.)

### RIDE model ice machine installation procedure (models MCD400A/WHS and MCD400A/WVS)

RIDE model ice machine performance is very sensitive to the quality of installation. To ensure proper performance, ease of service and warranty coverage, it is critical that you follow the requirements detailed in this manual. If you can not meet these requirements or have questions, call our technical service group immediately at (877) 612-5086 or +1 (610) 252-7301.

#### Installing RIDE model ice machine and rough-in utilities without optional slide-out accessory

The requirements below are for ice machine installation without the Follett slide-out accessory. These procedures ensure that the ice machine can be easily removed as one unit for cleaning and maintenance. For installation with the slide-out accessory, refer to instructions to install ice machine and rough-in utilities with optional slide-out accessory.

#### General requirements

- Front of ice machine free of obstructions, plumbing lines, electric conduits.
- 12" (305 mm) minimum clearance above ice machine for access to ice machine components.
- 6" (15.3 cm) minimum clearance between exhaust side of ice machine and adjacent equipment.
- Do NOT weld ice machine to counter channels.
- Large, removable panels in counter face to allow ice machine removal.
- Machine stand accessory required for ice machines not supported on counter channels.

#### Connection requirements

- Compression fittings for water and drain lines.
- Separate drains for condenser and ice machine. Do NOT connect drains.
- 20A power supply with 6 feet.

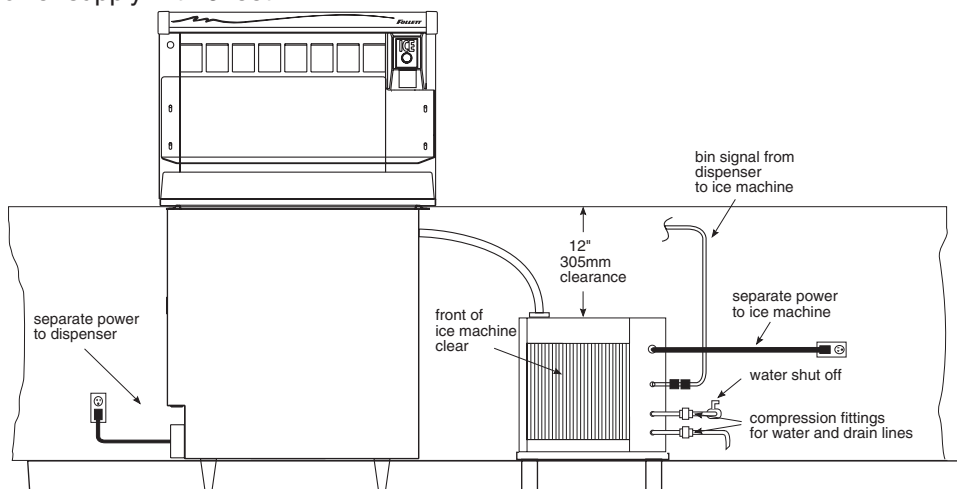

**Note:** Diagram intended as guide only. All field wiring to be installed in accordance with NEC and local electrical codes.

## Field wiring diagrams for RIDE model ice machine installations

- All field wiring must be installed in accordance with NEC and local electrical codes.
- Field wiring diagram is intended only to aid electrician or technician in understanding how equipment works.
- Should local codes require a hard-wired connection and/or shielded wiring, eliminate the cord and plug(s) and follow the appropriate field wiring diagram.
- MCD400A/W and R400A/W ice machines have separate power supply from dispenser.
- Electric disconnects required within 10 ft (3 m) for all hard-wired connections.

### Recommended junction box preparation of hard-wired RIDE model ice machines.

1. Cut plugs from supplied power cords.
2. Replace upper (power) strain relief with a cord connector.
3. Mount two 2" x 4" junction boxes using supplied holes in ice machine face.
4. Make power and bin signal connections.

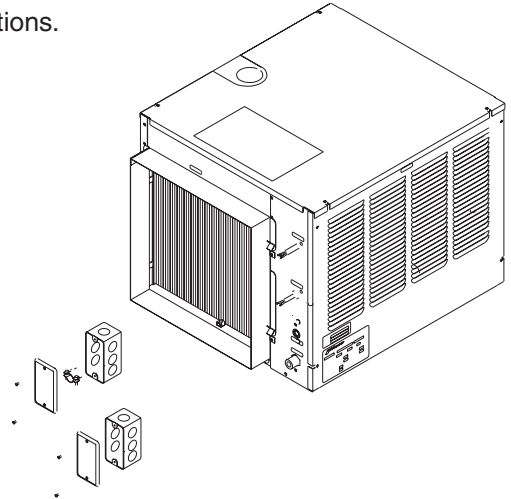

### 25, 50 or 110 ice and water dispenser with ONE RIDE model ice machine

(dispenser models 25CR400A/W, 25HR400A/W, 50CR400A/W, 50HR400A/W, 110CR400A/W)

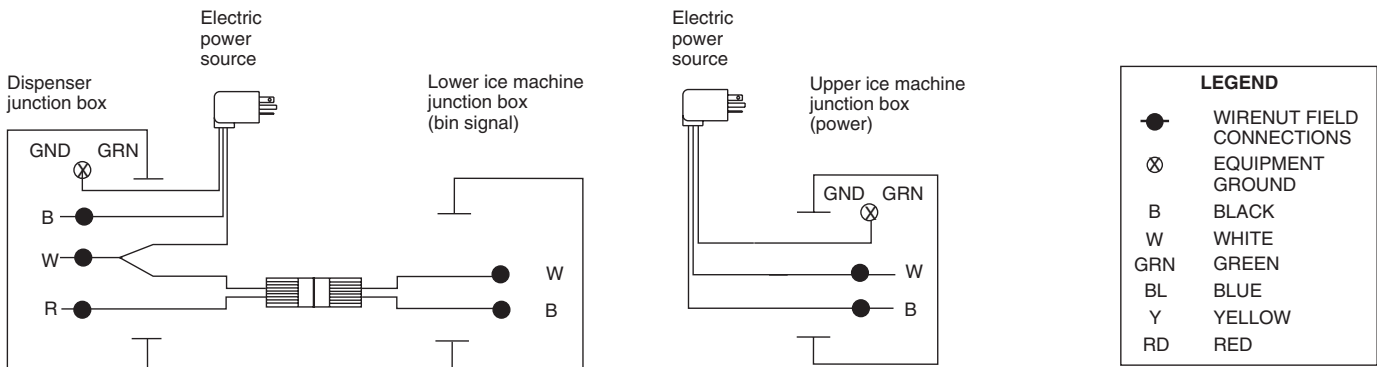

### VU155/VU300 ice and beverage dispenser with ONE or TWO RIDE model ice machines

**Note:** 24 V bin signal; Verify black bin signal wire is on the 24 V terminal

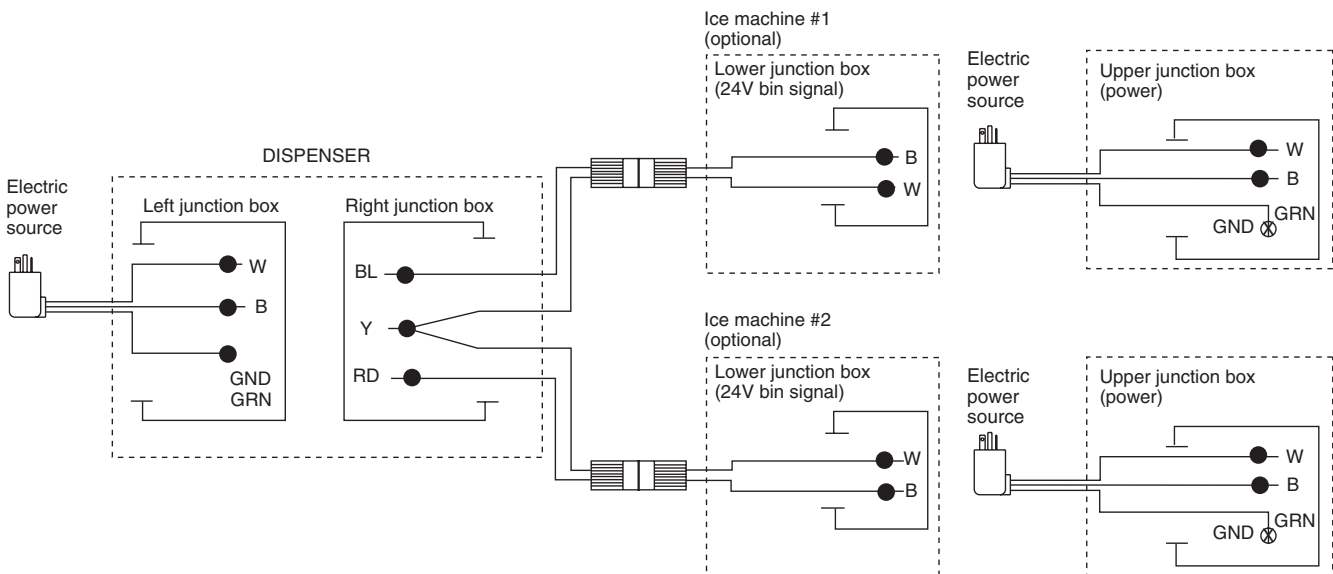

## Installing RIDE model ice machine and rough-in utilities with optional slide-out accessory

The slide-out accessory allows the ice machine to be pulled out on a track from below a counter without disconnecting utilities. A leg supports the ice machine in the full-out position. If your order did not include a slide-out accessory proceed to ice machine ventilation and exhaust.

### Step 1 – Installing track accessory (Follow either A or B below for RIDE model ice machine)

Track must be positioned flush against inside of counter and slightly above counter access opening.

#### A. When ice machine stand is used (required if ice machine is not supported on counter channels)

1. Bolt vertical utility panel to slide-out track assembly with supplied 10/32 screws.
2. Secure slide-out track assembly to ice machine stand with 10/32 screws provided.
3. Position ice machine stand in desired location and adjust stand legs to proper height and level in both directions.
4. Using holes in flanged legs as template, mark floor for 12 anchoring holes to be drilled.
5. Remove stand/track assembly and drill marked holes.
6. Reposition and anchor stand to floor with 12 fasteners appropriate to floor material (not supplied).

#### CAUTION!

*Stand must be anchored to avoid tipping and possible injury when ice machine is pulled out.*

#### B. When ice machine is supported on counter channels

1. Bolt vertical utility panel to slide-out track assembly with supplied 10/32 screws.
2. Position track assembly on counter channels (**Fig. 3**).
3. Using holes in track assembly as a template, mark and drill required holes in counter channels.
4. Remove track assembly on channels and drill marked holes.
5. Reposition track assembly on channels and secure using appropriate hardware (not supplied).

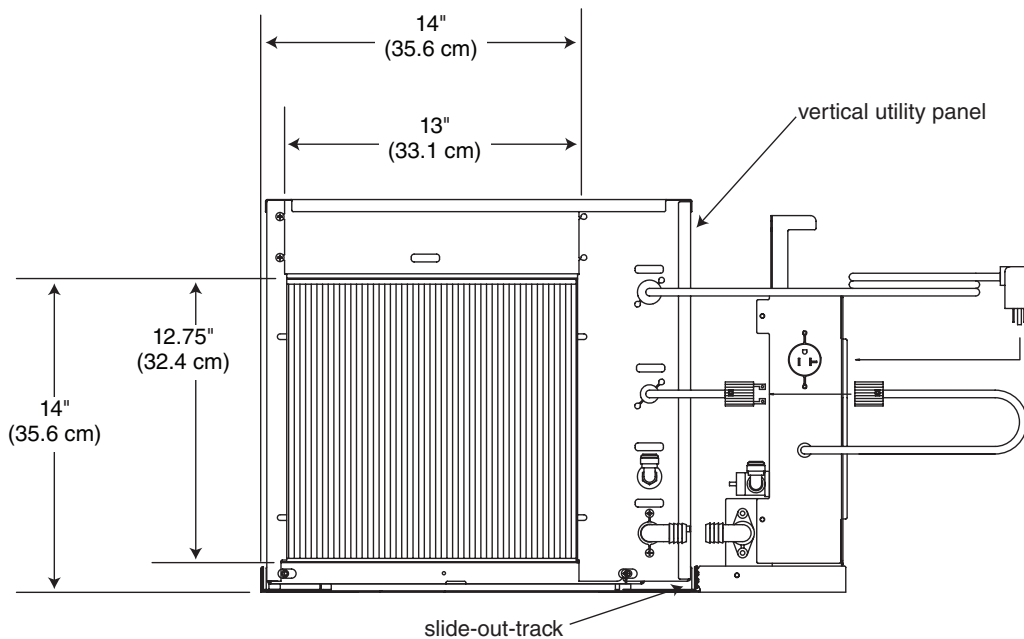

## Step 2 – Installing RIDE model ice machine on slide-out track

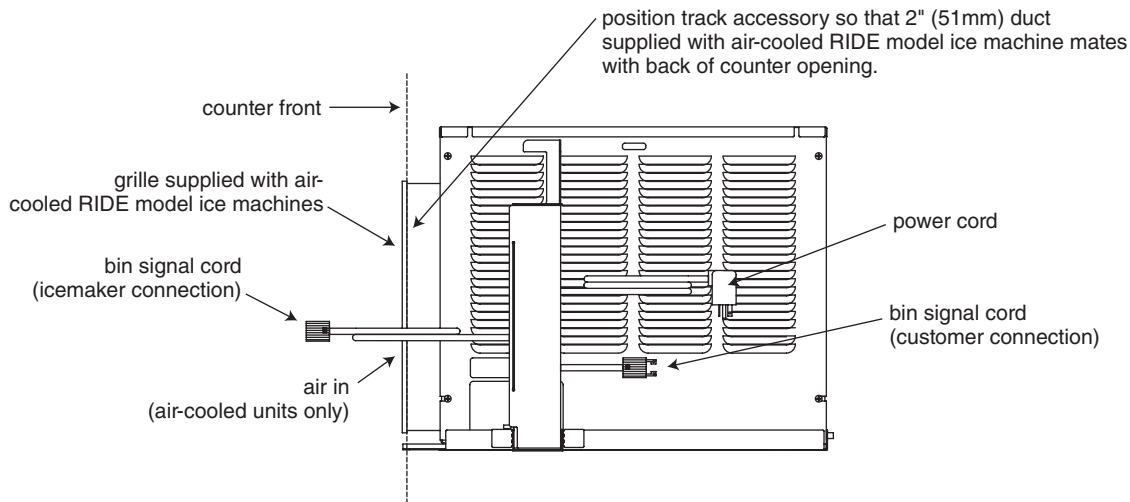

### A. When ice machine is shipped with slide-out track accessory (follow either A or B)

1. Connect inlet water, drain, and power supply to back of vertical utility panel.
2. Place ice machine on slide-out track assembly.
3. Connect drain and water lines.
4. Connect electrical plugs from ice machine to utility panel.

### B. When ice machine is installed in and shipped with counter

1. Remove two outer rear screws from ice machine and install supplied spacer and screw (**Fig. 3**).
2. Place ice machine on slide-out track assembly.
3. Connect drain and water lines.
4. Connect electrical plug from ice machine to utility panel.
5. Remove pin from adjustable leg.
6. Place hold-down strap over leg block and secure strap to slide-out assembly with supplied screws (**Fig. 4**).
7. Reinstall pin in leg block.
8. At job site remove hold-down strap and make utility connections at rear utility panel.

**Fig. 3**

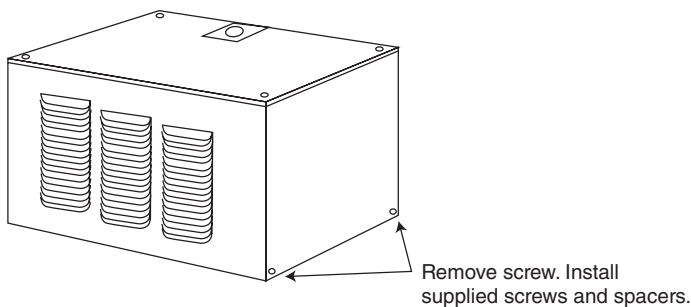

**Fig. 4**

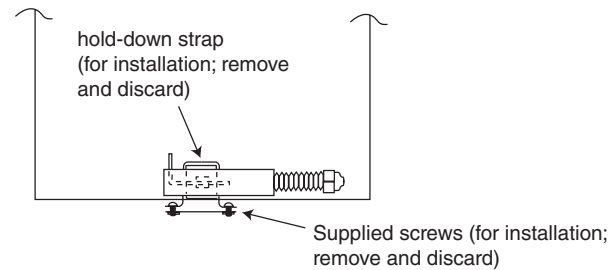

**Front view**

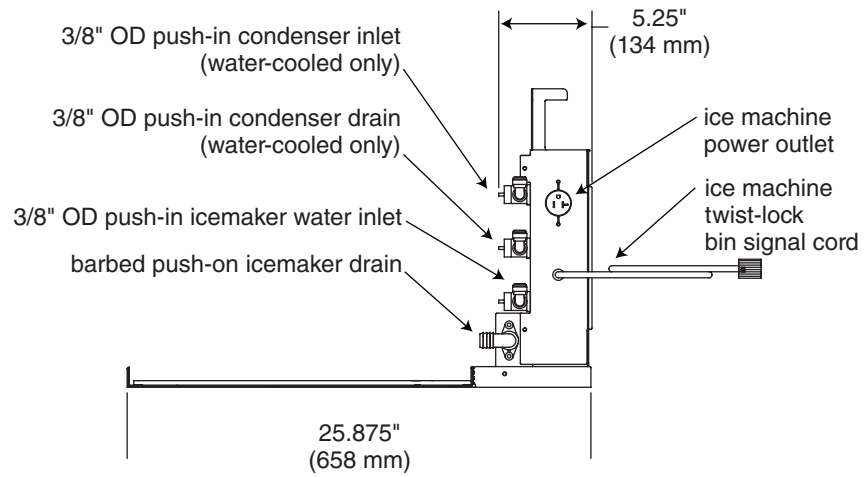

**Side view**

(All customer field connections are made to rear of vertical utility panel)

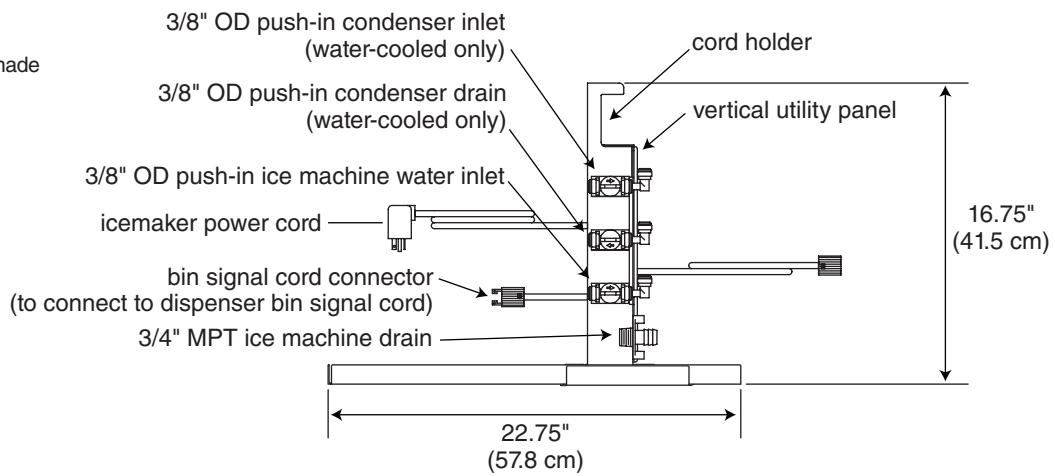

**Plan view**

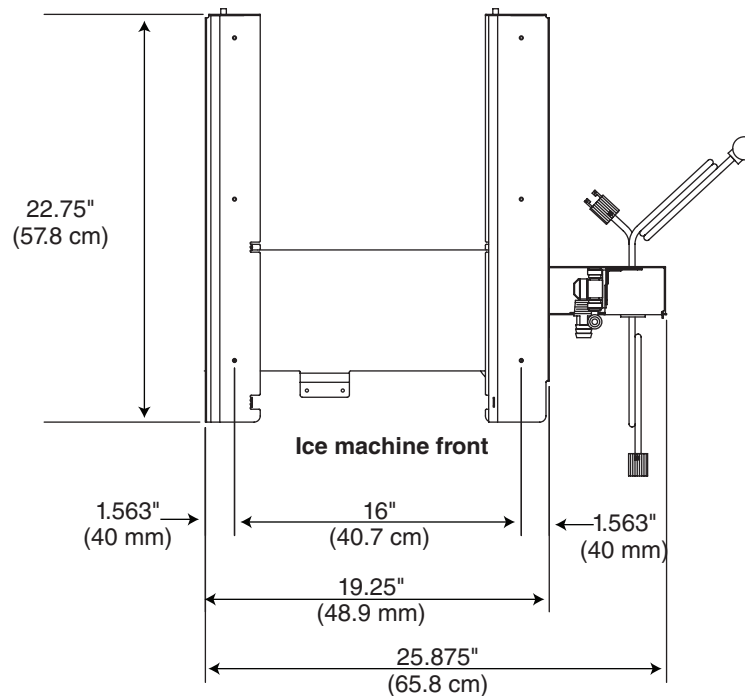

## RIDE model ice machine ventilation and exhaust requirements

Fabricator-supplied, custom air intake grilles must have 12" x 12" (30.5 cm x 30.5 cm) opening yielding 100 sq. inches (645 sq. cm) of open air space within duct perimeter. Block off any open area outside of the air duct.

### Intake air requirements — air-cooled ice machines (MCD400AHS, MCD400AVS & R400A only)

1. Check that 2" (51 mm) duct is installed on condenser front.
2. Cut a 12" x 12" (30.5 cm x 30.5 cm) opening in counter face to align with duct.
3. Position ice machine to mate duct flush with back of counter opening.
4. Install supplied grille on outside of counter opening.

### Exhaust air — all ice machines (MCD400A/W & R400A/W)

Provide 100 sq. in. (645 sq. cm) of counter opening for exhaust air at least 18" (45.7 cm) from intake opening but not more than 10 ft (3 m) away.

### MCD400AHS, MCD400AVS & R400A — Side View

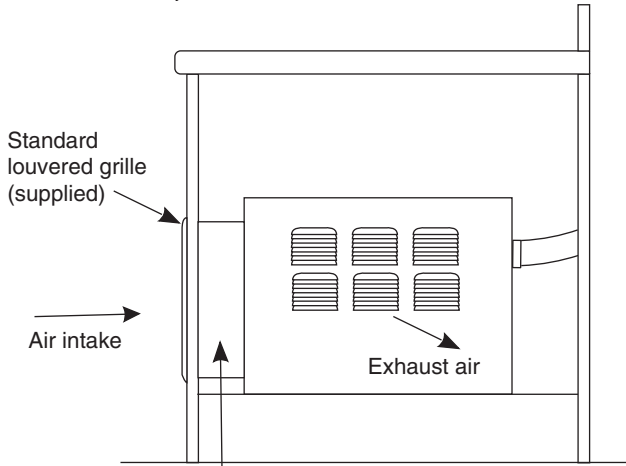

Supplied 2" (51mm) duct MUST be installed to front of ice machine and mated flush to inside of counter face opening.

Front View

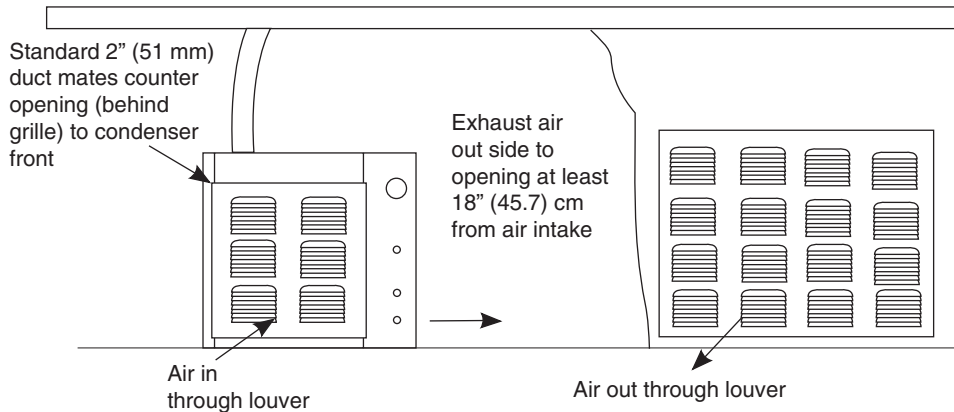

Provide at least 100 sq. in. (645 sq. cm) of counter opening for exhaust air

## RIDE model ice machine ice transport tube installation

Incorrect ice transport tube installation can result in wet ice and dispensing problems. Follow guidelines below to ensure correct installation. Call factory for assistance if you are unable to meet these requirements.

### General requirements

- Maximum length of tube run – 20 ft (6 m). Factory approval required for longer runs.
- Run tube without dips.
- One continuous length of tube; no splices.
- Minimum radius of bends in tube – 6" (15.3 cm) inside radius.
- Maximum number of bends – 6.
- Insulation on entire run of ice tube.

### Procedure

1. If installing MCD series ice machine refer to additional connection specifications for Vision series ice and beverage dispensers instructions below.
2. Select side, rear or top knockout in ice machine cabinet for tube entrance.
3. Install supplied grommet in knockout.
4. Remove ice machine top panel.
5. Install supplied insulation on entire length of tube.
6. Run insulated tube without dips between ice machine and dispenser and secure in place.
7. Cut insulation off tube where tube enters grommet.
8. Slide end of tube without insulation through grommet and run to evaporator port.
9. Cut tube to that length.
10. Install a section of insulation on tube from grommet to evaporator port.
11. Slip supplied hose clamp over free end of tube.
12. Pull insulation back from free end of tube.
13. Push tube on evaporator port.
14. Position clamp behind lip on evaporator port and tighten clamp.

### Correct installation

- Length of run no more than 20 ft (6 m)
- Tube run continuously from ice machine to dispenser
- Insulation on entire run of tube
- No dips or tight bends
- Tube secured in place
- No splices

### Incorrect installation

- Dips in tube where water can collect
- Splice or tight bend that restricts ice flow
- Uninsulated tube that results in wet ice and potential dispensing problems

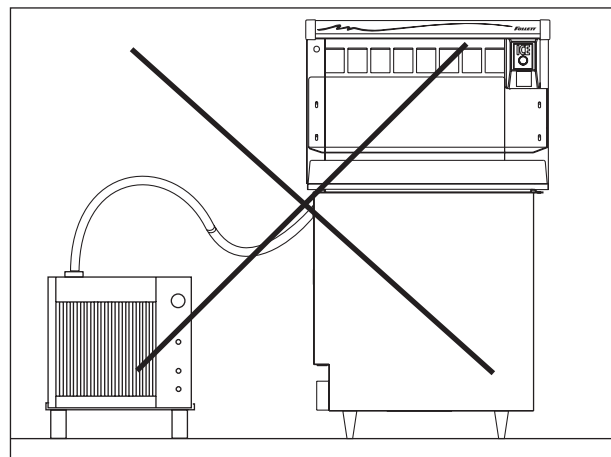
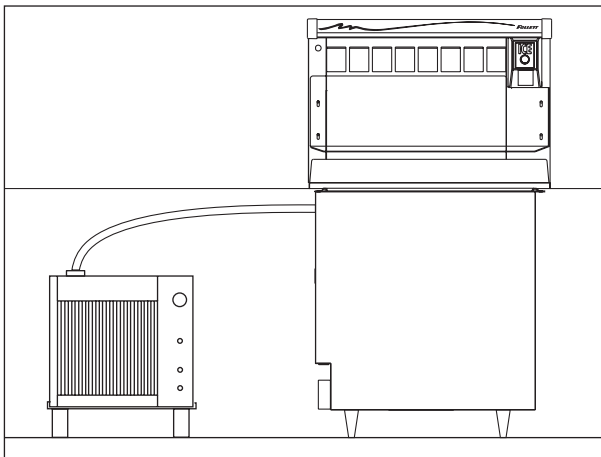

## Additional ice transport tube connection specifications for Vision series ice and beverage dispensers

Check to make sure bin signal on ice machine control board is switched to 24 V connection.

1. Push one end of ice transport tube(s) through hole(s) provided in side of dispenser.
2. Route tube into ice tube bracket inside dispenser and engage bracket tabs in holes located in end of ice transport tube(s) (see drawings below).
3. Verify bin thermostat capillary tube is mounted correctly (see drawings below).

### Ice tube retainer bracket

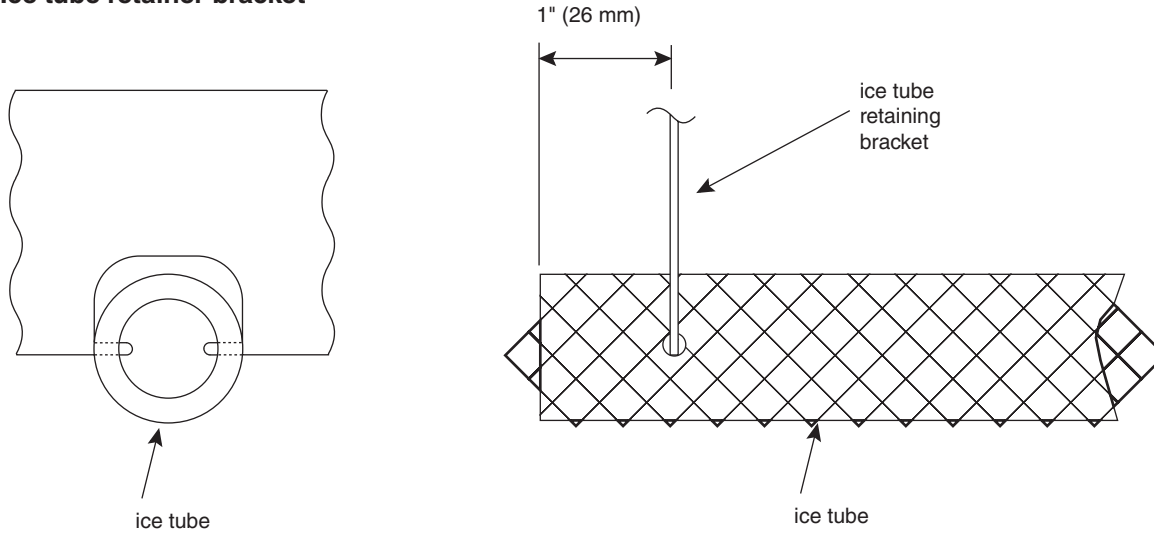

### Bin thermostat capillary tube mounting

Front View, VU155

Front View, VU300

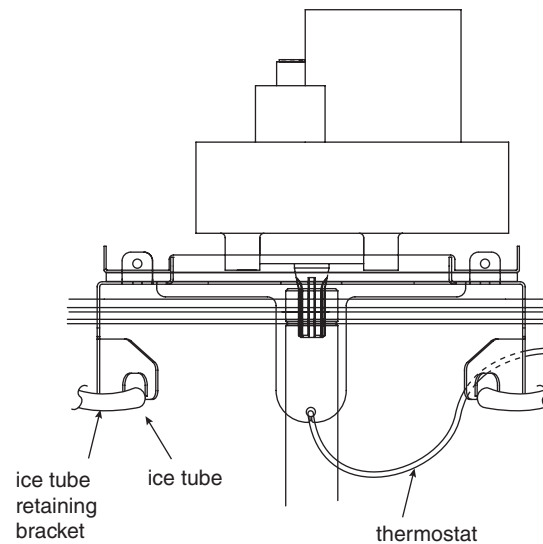
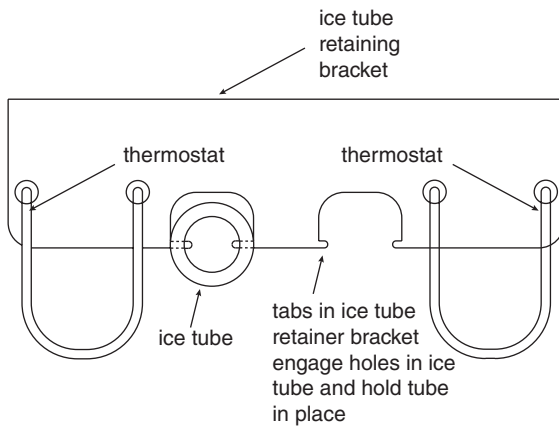



## Ice transport tube installation detail

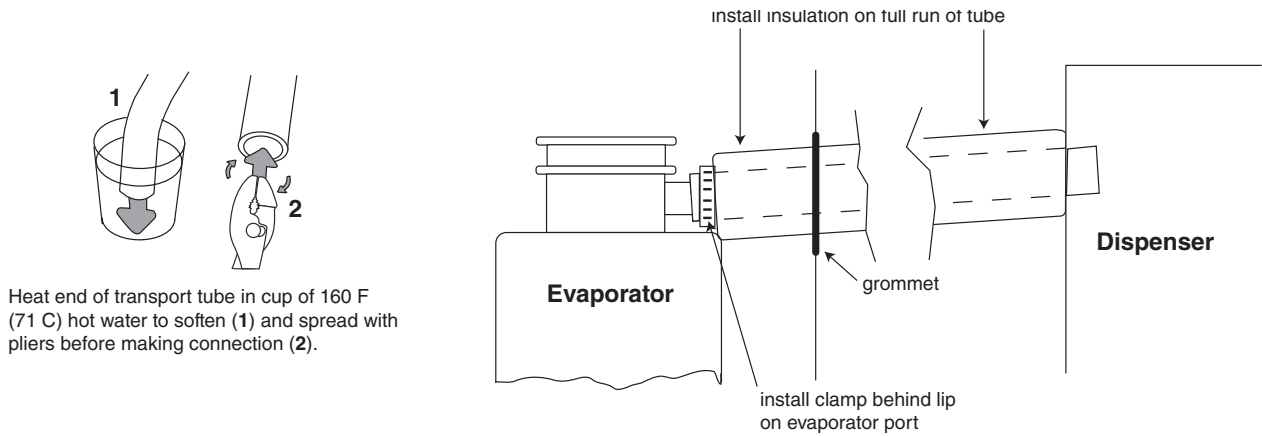

## RIDE model ice machine start up procedure

The start-up procedure below is intended to ensure that ice machine is operating properly after installation has been made. Check each item listed and call factory immediately for assistance if you experience problems with unit.

### Before turning on power

1. Turn on water to ice machine.
2. Push down on float to force water through overflow chamber into evaporator drain pan and check for proper drainage of drain pan.
3. Check that float valve shuts off incoming water when raised.
4. Check that hose clamp securely holds ice transport tube on evaporator port.

### After turning on power

1. Turn on power to ice machine and confirm that gearmotor, fan motor and compressor start immediately.
2. Check that ice begins to enter dispenser bin area within approximately 10 minutes.
3. Check that float reservoir water level is approximately 3/8" (.95mm) below overflow during ice machine operation and adjust to this level if necessary.
4. Put ice against bin level thermostat in dispenser bin and check that compressor and fan motor shut down approximately 10 seconds after thermostat opens. Gearmotor should run for an additional 60 seconds.
5. Check that ice machine comes back on in approximately 20 minutes (bin signal must be present).

## Cleaning/descaling and sanitizing

Periodic cleaning/descaling and sanitizing of Follett's ice machine system is required to ensure peak performance and delivery of clean, sanitary ice. The recommended cleaning procedures that follow should be performed at least as frequently as recommended and more often if environmental conditions dictate.

Cleaning of the condenser can usually be performed by facility personnel. Cleaning/descaling and sanitizing of the ice machine system should be performed by your facility's trained maintenance staff or a Follett authorized service agent. Regardless of who performs the cleaning, it is the operator's responsibility to see that this cleaning is performed according to the schedule below. Service problems resulting from lack of preventive maintenance will not be covered under the Follett warranty.

Symphony	Frequency
Drain Line	weekly
Drain Pan/Drip Pan	weekly
Exterior	as needed
Condenser	monthly (air-cooled only)
Ice Machine	semi-annually
Transport Tube	semi-annually

\* Ice machine must be cleaned and sanitized prior to start-up.

## Weekly

The exterior may be cleaned with a stainless cleaner such as 3M\* Stainless Steel Cleaner & Polish or equivalent.

\* 3M is a trademark of 3M Company.

## Monthly

### Condenser (air-cooled ice machine only)

1. Use a vacuum cleaner or stiff brush to carefully clean condenser coils of lint and debris to ensure optimal performance.
2. When reinstalling counter panels in front of RIDE model ice machines, be sure that ventilation louvers line up with condenser air duct.

### Semi-Annually (more often if conditions dictate)

- A cleaning/descaling and sanitizing procedure should always include both the ice machine and dispenser; ice machine should be cleaned and sanitized first, followed by the dispenser.
- Icemaking system can be cleaned/descaled in place.

To ensure that your ice machine and dispenser are cleaned/descaled and sanitized properly, proceed as follows:

1. Clean/descale the ice machine
2. Sanitize the ice machine
3. Clean/descale the dispenser
4. Sanitize the dispenser



### CAUTION!

- Wear rubber gloves and safety goggles (or face shield) when handling cleaner or sanitizer mixtures.
- Use only Follett approved cleaners.
- It is a violation of Federal law to use Solution A or Solution B in a manner inconsistent with their labeling.
- Do not use solvents, abrasive cleaners, metal scrapers or sharp objects to clean any part of the dispenser.

**Solution A:** Following manufacturer's instructions, mix cleaning solution of 1 gal. (3.8 L) 120 F (49 C) water and 7 oz. (198 g) (one 7 oz. packet) of Follett SafeCLEAN™ ice machine cleaner/descaler (P/N 00132001).

**Solution B:** Following manufacturer's instructions, mix a sanitizing solution of 1 gal. (3.8 L) 120 F (49 C) water and 1.6 oz. (48 ml) Nu-Calgon IMS-II Sanitizer (P/N 00979674).

### Clean/descale ice machine

1. If ice machine was running recently, ensure that the evaporator is completely free of ice before proceeding.
2. Disconnect power to ice machine.
3. Remove any ice machine panels required to gain access to water reservoir and electrical control box.
4. Turn compressor switch on electrical box of ice machine to OFF position.
5. Remove water reservoir cover and close water supply valve (or block up reservoir float).
6. Drain water from reservoir by releasing evaporator drain tube from float reservoir bracket, removing plug from drain tube and releasing (unclamping) pinch clamp (if equipped).
7. Plug drain hose, replace drain line in reservoir bracket and pour part of **Solution A** into reservoir, filling it almost to overflowing.
8. Remove stainless steel ice compression nozzle and drain lines and submerge in a cup of **Solution A** while cleaning/descaling rest of system. (Flake ice machines have no ice compression nozzle and drain lines.)  
**CAUTION:** To avoid potential pitting, do not soak parts in **Solution A** for more than 45 minutes.
9. Restore power to ice machine (garmotor will run; compressor and fan will not).
10. Inspect evaporator drain pan and drain line and remove any accumulated scale build up.
11. After 15 minutes, turn power OFF; drain solution from reservoir and evaporator.
12. Fill reservoir almost to overflowing with clean water to rinse. Drain. Repeat two more times.
13. Rinse ice compression nozzle and drain lines in clean water.

### Sanitize ice machine

14. Submerge ice compression nozzle and drain lines in a cup of **Solution B** while following steps 15-21.
15. Connect ice transport tube directly onto evaporator outlet port without ice compression nozzle.
16. Fill reservoir almost to overflowing with **Solution B**.
17. Restore power to ice machine (garmotor will run; compressor and fan will not).
18. After 10 minutes, turn compressor switch to ON position.
19. As unit starts to make ice, continue to pour **Solution B** into reservoir, maintaining level just below reservoir overflow.

20. Continue to make ice with **Solution B** for 20 minutes.
21. Turn power to ice machine OFF.
22. Disconnect ice transport tube from evaporator outlet port. Rinse ice compression nozzle and drain lines in clean water and reinstall on evaporator outlet. Reconnect ice transport tube to ice compression nozzle.
23. Drain any remaining **Solution B** from evaporator.
24. Fill reservoir almost to overflowing with 120 F (49 C) clean water to rinse. Drain. Repeat two more times. Re-clamp pinch clamp, replace drain plug, and re-secure drain tube *ensuring that end of drain tube is above water level in reservoir*.
25. Open water supply valve (or unblock float) and replace reservoir cover; restore power to ice machine and ensure compressor switch is in ON position. Make ice for at least 15 minutes to flush any remaining **Solution B** from system (RIDE ice machines with long ice transport hoses may take longer to flush out). Discard this ice and all ice made during sanitizing.
26. Reinstall all parts and replace any panels removed prior to cleaning.

## Service

### Ice machine Operation (all models)

Follett's ice machine consists of four distinct functional systems:

- Refrigeration system
- Water system
- Harvesting system
- Electrical control system

These four systems work together to accomplish the production and harvesting of ice. A problem in any one of these systems will result in improper operation of the entire ice production cycle. When troubleshooting the ice machine, it is important to analyze the entire system operation to determine which system is not functioning properly, then pinpoint the component within that system that is malfunctioning. Determine what corrective action must be taken before making any adjustments or replacing any components.

### The icemaking process

The Follett ice machine uses a stainless steel jacketed evaporator and operates on a continuous freezing cycle. Water is supplied to the evaporator from the water reservoir where the water level is controlled by a float valve. This valve also shuts off the water supply when the ice machine is not running.

When the ice machine is running, a layer of ice forms on the interior surface of the evaporator. This ice is continuously removed by a slowly rotating (12 RPM) auger. The auger carries the ice upward into the cavity formed by the top bearing housing and the compression loop, where it is compressed to remove excess water. When the ice reaches the desired hardness it rotates within the cavity and is forced through a discharge port and compression nozzle and into the ice transport tube. The discharge tube and compression nozzle are slightly restricted to further compress the ice and produce the desired hardness.

**Note:** MFD series flake ice machines have no compression nozzle. As the formation of ice continues, ice in the transport tube is pushed through the tube to the storage compartment in the ice dispenser or ice storage bin.

A solid state control board located in the electrical box of the ice machine controls the normal operation of the ice machine and monitors gearmotor torque.

This control board will shut down the ice machine should an over-torque condition occur. It is very important that you familiarize yourself with the operational sequences detailed in this manual before attempting to service the ice machine.

Harvest system diagram

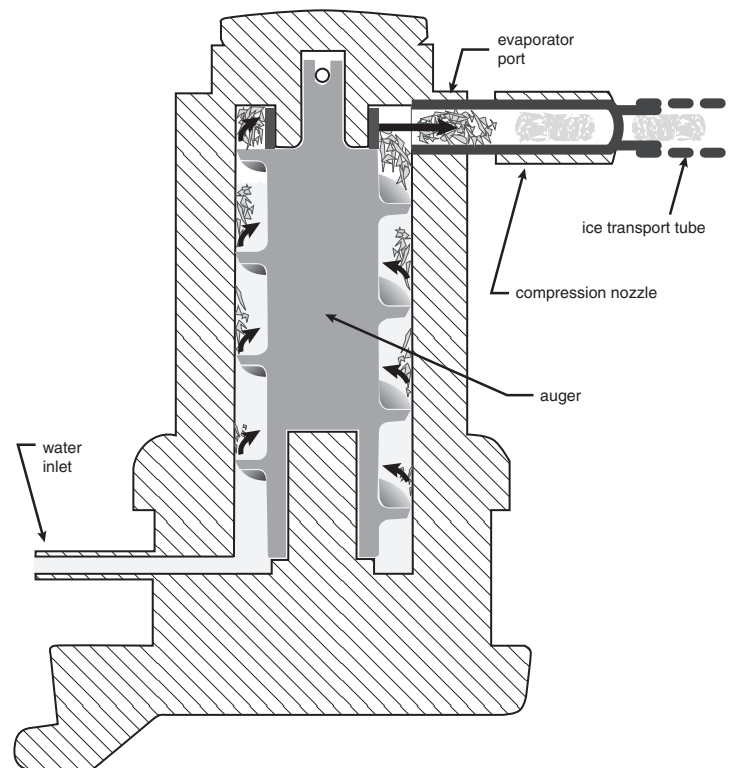

## Technical specifications (all models)

### Refrigeration system diagram

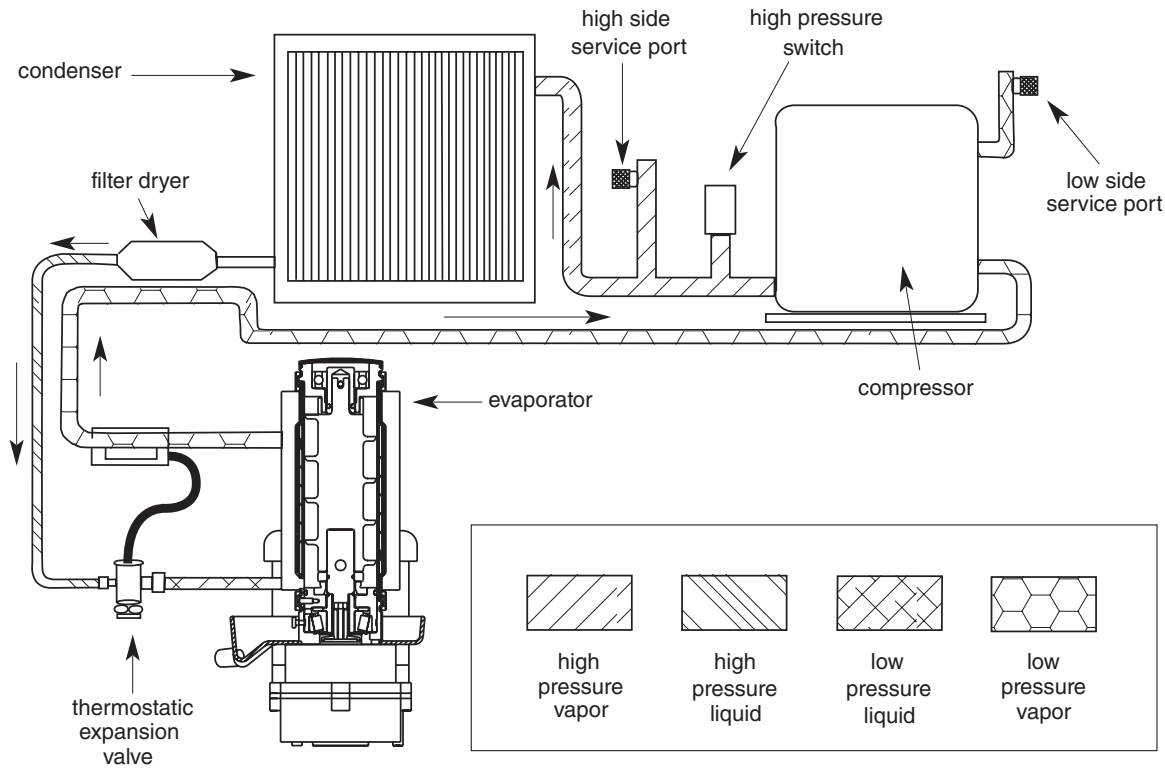

### Refrigeration pressure data

- Water regulating valve is factory set at 225 PSIG head pressure.
- Readings within 10% of table values should be considered normal.

#### Air-cooled Ice Machine Refrigeration Pressure

Discharge Pressure/Suction Pressure

Ambient air temperature °F/°C

Ice machine inlet water temperature °F/°C	°F/°C		60/16		80/27		100/38		
	50/10	174/23	245/31	237/37	psi				
70/21	174/23	244/30	326/38	psi					
90/32	190/25	265/32	347/40	psi					

#### Water-cooled Ice Machine Refrigeration Pressure

Discharge Pressure/Suction Pressure

Condenser inlet water temperature °F/°C

Ice machine inlet water temperature °F/°C	°F/°C			50/10			70/21			90/32			
	50/10	236/28	235/29	250/34	psi								
70/21	237/28	230/30	250/34	psi									
90/32	236/28	235/30	250/34	psi									

### Compressor data

#### Compressor current draw

Air-cooled					
Ambient air temperature	60 F/15.6 C	70 F/21.1 C	80 F/26.7 C	90 F/32.2 C	100 F/37.8 C
	6.3A	6.5A	6.7A	6.9A	7.1A
Water-cooled					
Water temperature at float	50 F/10 C	60 F/15.6 C	70 F/21.1 C	80 F/26.7 C	90 F/32.2 C
	6.6A	6.7A	6.7A	6.8A	6.9A

Locked rotor amps 58.8A

### Air-cooled ice machine capacity/24 hrs.

### Water-cooled ice machine capacity/24 hrs.

Performance with new RG Group 1/2 ton coil  
(Note: Data expressed in lbs/hr and kg/hr)

Ambient Air Temperature °F/°C

Ambient Air Temperature °F/°C

Inlet Water Temperature °F/°C	Ambient Air Temperature °F/°C					
	F 60	70	80	90	100	
C 16	21	27	32	38		
50	510	454	397	335	273	lbs.
10	232	206	180	152	124	kg.
60	482	435	389	329	270	lbs.
16	219	198	177	150	123	kg.
70	454	417	380	323	266	lbs.
21	206	190	173	147	121	kg.
80	424	385	347	297	247	lbs.
27	193	175	158	135	112	kg.
90	394	354	313	270	227	lbs.
32	179	161	142	123	103	kg.

Inlet Water Temperature °F/°C	Ambient Air Temperature °F/°C					
	F 60	70	80	90	100	
C 16	21	27	32	38		
50	451	447	442	437	428	lbs.
10	204	202	200	199	194	kg.
60	423	413	409	399	394	lbs.
16	192	187	185	181	179	kg.
70	394	390	380	371	361	lbs.
21	179	177	172	168	163	kg.
80	371	361	352	342	333	lbs.
27	168	163	160	155	151	kg.
90	352	342	333	323	309	lbs.
32	160	155	151	146	140	kg.

Note: Nominal values – actual production may vary by ± 10%

#### Gearmotor data

Gearmotor current 2.25A (nominal)  
Locked rotor amps 14A

## Electrical control system operation

### MCD400A/WBT, MCD400A/WHT and MFD400A/WBT wiring diagram

Follett ice machines used on top of an ice storage bin have a slightly different circuitry. A diagram for these ice machines is shown below. The operational and diagnostic stages for these ice machines will be otherwise the same as the following Stages 1 - 10.

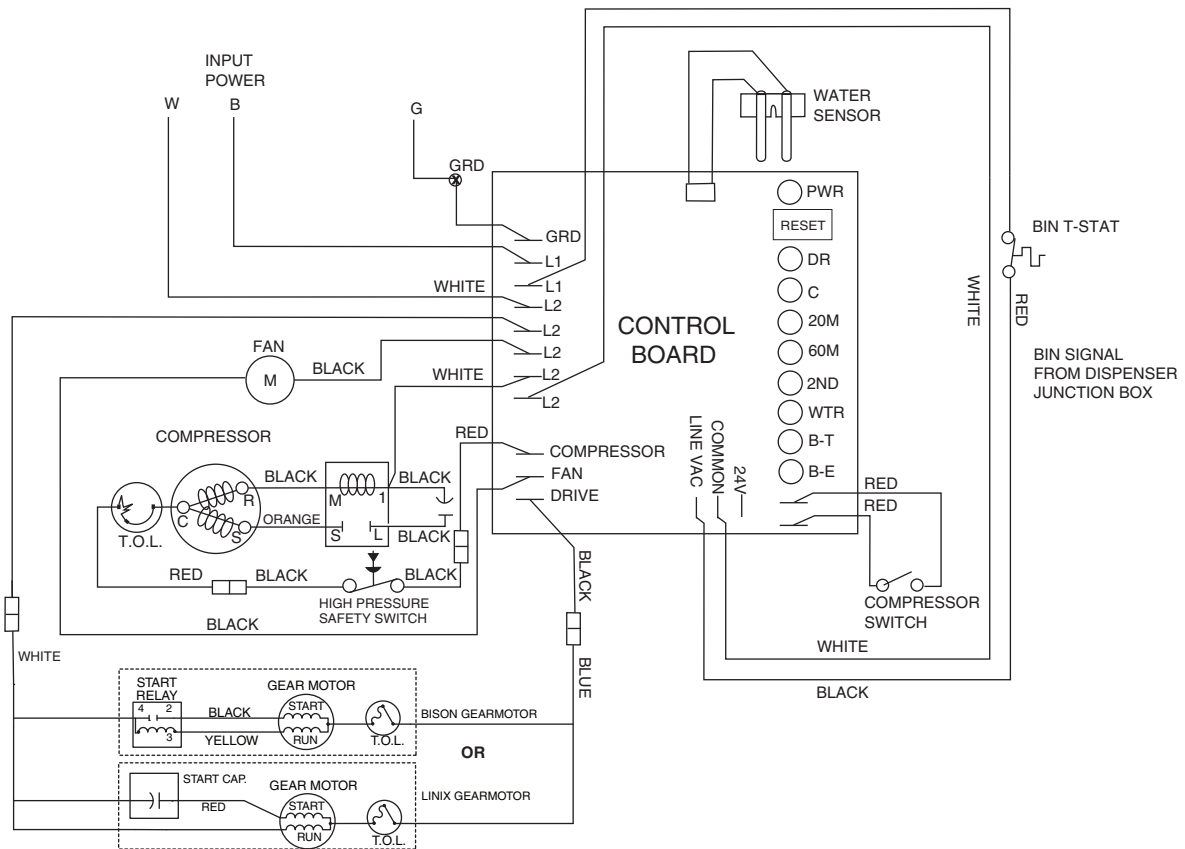

## Electrical control system operation

The D400A/W, MCD400A/WVS and R400A/W wiring diagrams which follow illustrate the circuitry of Follett ice machines used with ice dispensers. Both normal operation of the ice machine (Stages 1 - 6) and non-normal diagnostic sequences showing torque-out (Stages 7 - 10) for use in troubleshooting ice machine problems are shown.

Follett ice machines used on top of an ice storage bin have a slightly different circuitry. The operational and diagnostic stages for these ice machines will be otherwise the same as Stages 1 - 10 that follow.

## Circuitry notes

When the ice machine is used with a dispenser it receives power from two sources – the main power supply and the bin control signal power from the dispenser. Disconnect both power sources before performing service. When performing electrical service, always use a meter to determine whether or not the components being serviced are energized.

- High pressure cutout opens at 425 PSI and closes at 287 PSI (auto reset).
- Compressor switch should read open in on position.
- Compressor start relay is position sensitive. See label on start relay for proper orientation.
- Bin signal may be 120 V, 60 Hz; 230 V, 50 Hz; or 24 V, 60 Hz. If bin signal is 24 V, 60 Hz, black bin signal wire must be moved from LINE VAC terminal to 24 V terminal.
- Flashing water LED at any time indicates that water signal to board had been lost for more than one second.
- Ten-second delay: There is a 10 second delay in reaction to loss of water (WTR) or bin (B-E) signals. If signals are not lost for more than 10 seconds, no reaction will occur.

## Normal operation – Stage 1

Power is supplied to L1 of the control board. The ice level control in the dispenser is closed and calling for ice, supplying signal voltage to the control board. The control board will now go through the start-up sequence. Less than 30 seconds will elapse as the water sensor located in the float reservoir checks for water in the reservoir. The Bin Empty LED (B-E) will be on.

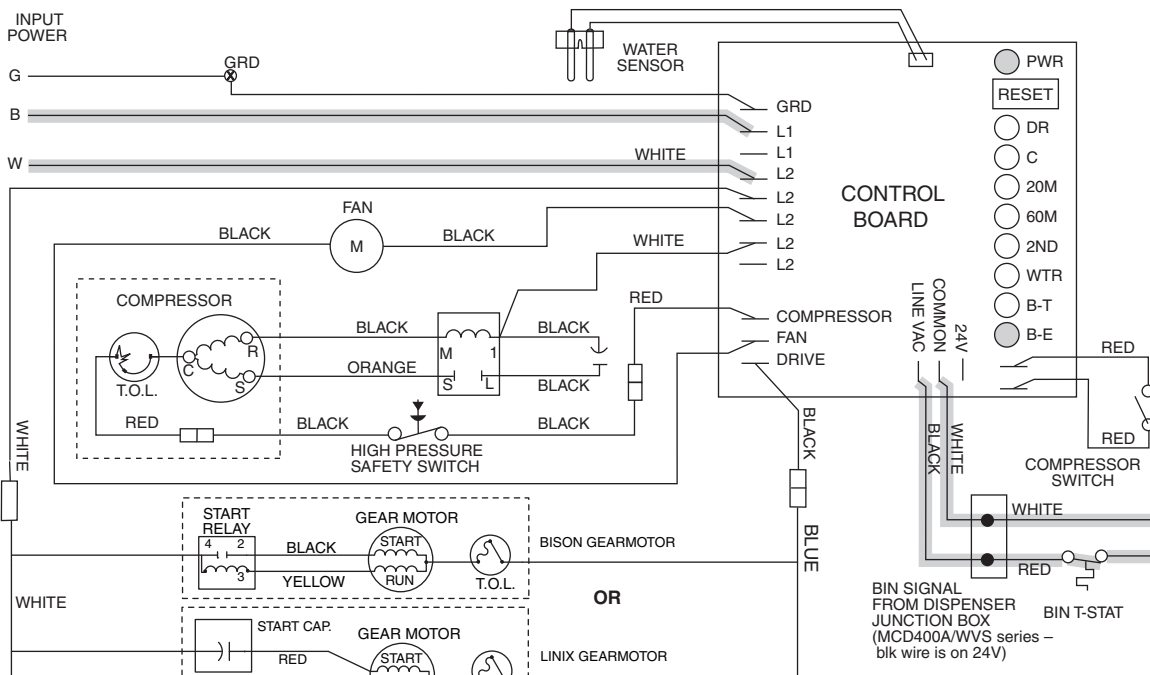

### Normal operation – Stage 2

The water sensor verifies water in the float. The Water OK LED (WTR) comes on. At the same time, the gearmotor, compressor, and condenser fan motor come on, lighting the Drive LED (DR) and compressor LED (C). The compressor is started through a current style relay that is pulled in by the initial high current draw of the compressor. The gearmotor start windings are also energized through a current relay (or start capacitor). The B-E and WTR LED remain on.

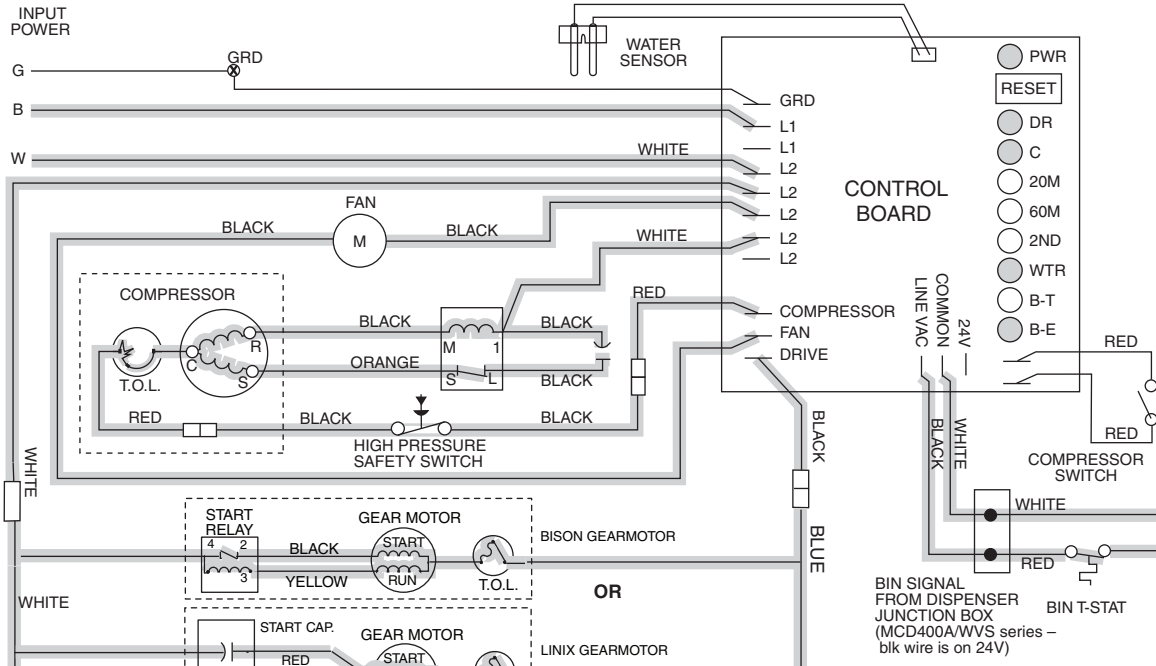

### Normal operation – Stage 3

After the initial high current draw drops off, the gearmotor start relay contacts open dropping out the start winding (or start capacitor). As the compressor comes up to normal running speed, the compressor start relay contacts open, dropping out the start winding of the compressor. The ice machine is now in a normal icemaking mode. The ice machine will produce ice until the bin level control in the ice dispenser is satisfied. The B-E, DR, C and WTR LEDs are all on.

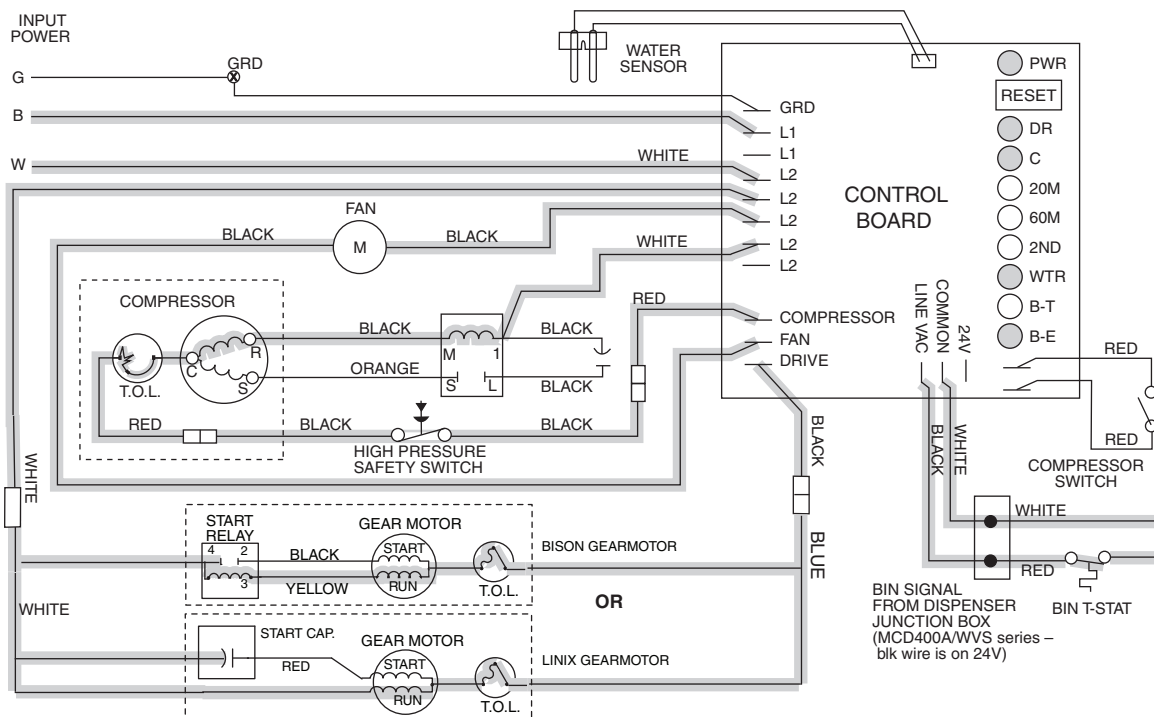

### Normal operation – Stage 4

Once the ice level control opens, the B-E LED goes out. After a 10 second delay the LED (C), compressor, and fan motor go off and the B-T LED comes on. (Should the ice level control not remain open for 10 seconds, the ice machine will continue to run.) The gearmotor continues to run for 60 seconds. The purpose of this function is to drive the remaining ice out of the evaporator and to boil off any refrigerant remaining in the evaporator.

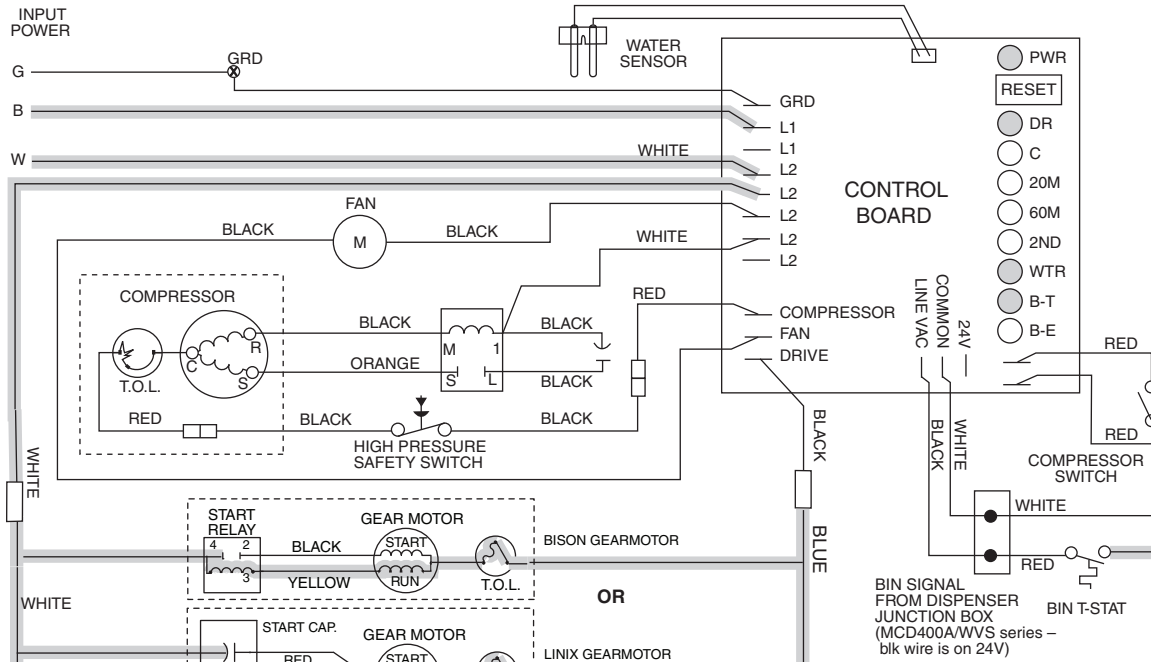

### Normal operation – Stage 5

The B-T LED will remain on for 20 minutes. The ice machine will not start while the B-T LED is on. To restart the ice machine for troubleshooting purposes, depress the reset button to clear the control board.

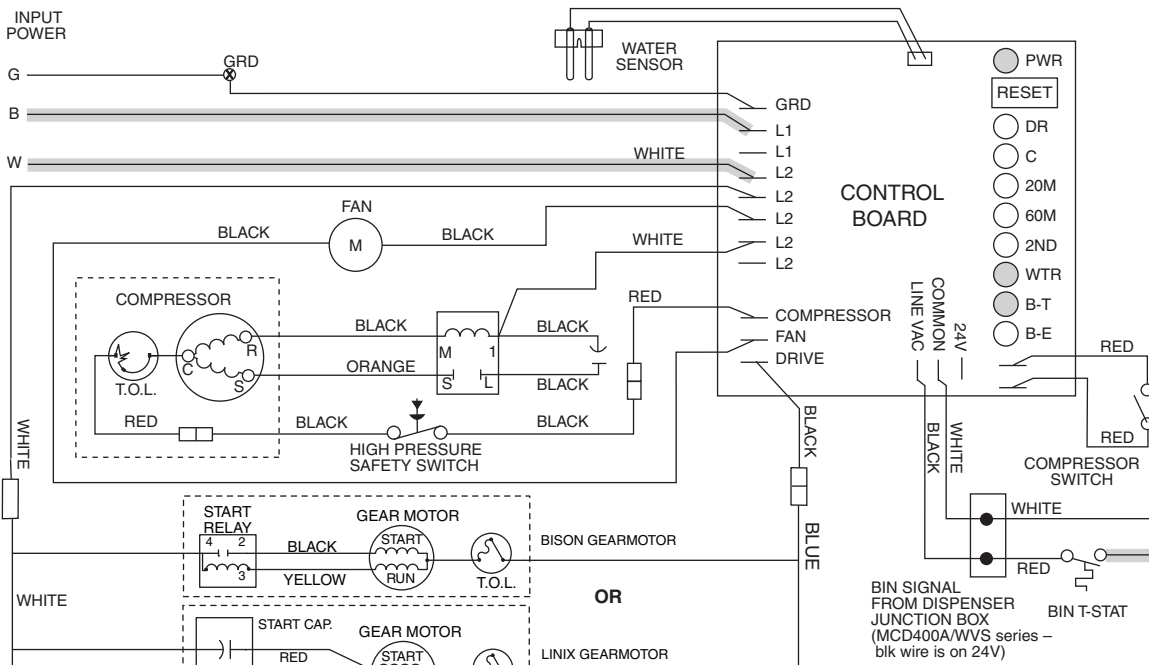



### Normal operation – Stage 6

When the dwell time of 20 minutes has expired, the B-T LED goes off. The ice machine will go through the normal start-up sequence when the bin level control signals the control board for ice. The WTR LED will remain on as long as the water sensor in the float reservoir senses water.

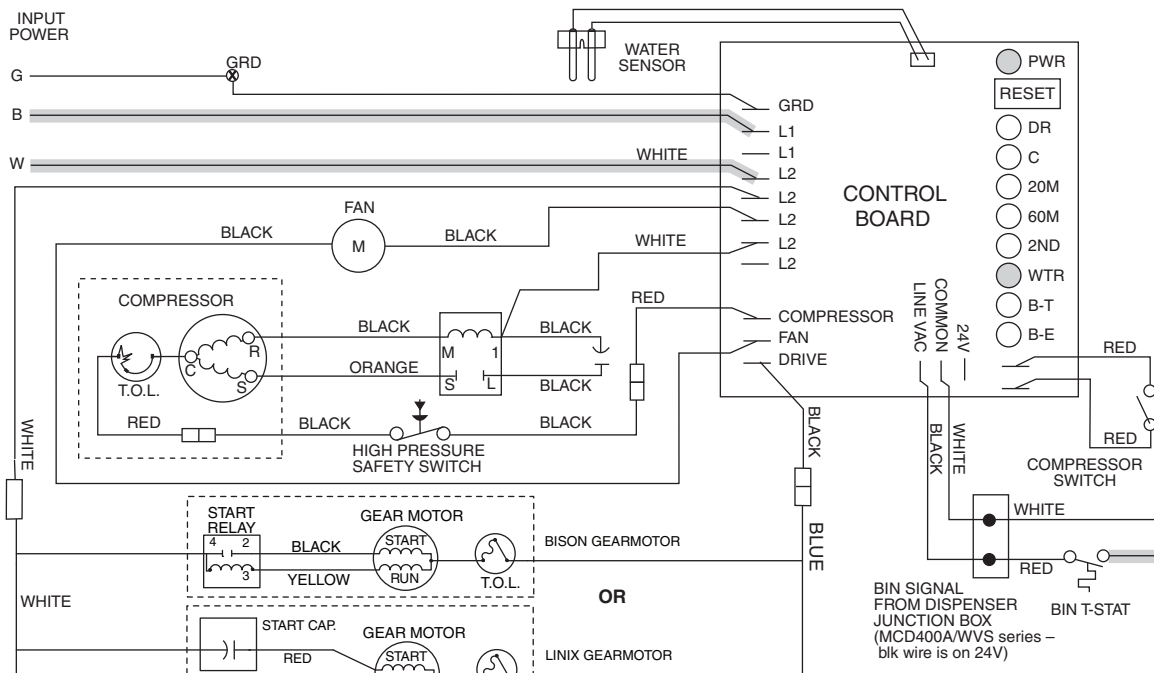

### Diagnostic sequence – Stage 7

The 20 minute error LED (20M) is on indicating that the control board has sensed an over-torque condition (above 3A on the gearmotor) and shut the ice machine down. The 20M LED will remain on for 20 minutes after an over-torque condition has occurred. The ice machine will remain off as long as the 20M LED is on. When the 20M LED goes off, the control board will try to go through a normal start-up sequence. The WTR LED remains on as long as the water sensor in the float reservoir senses water.

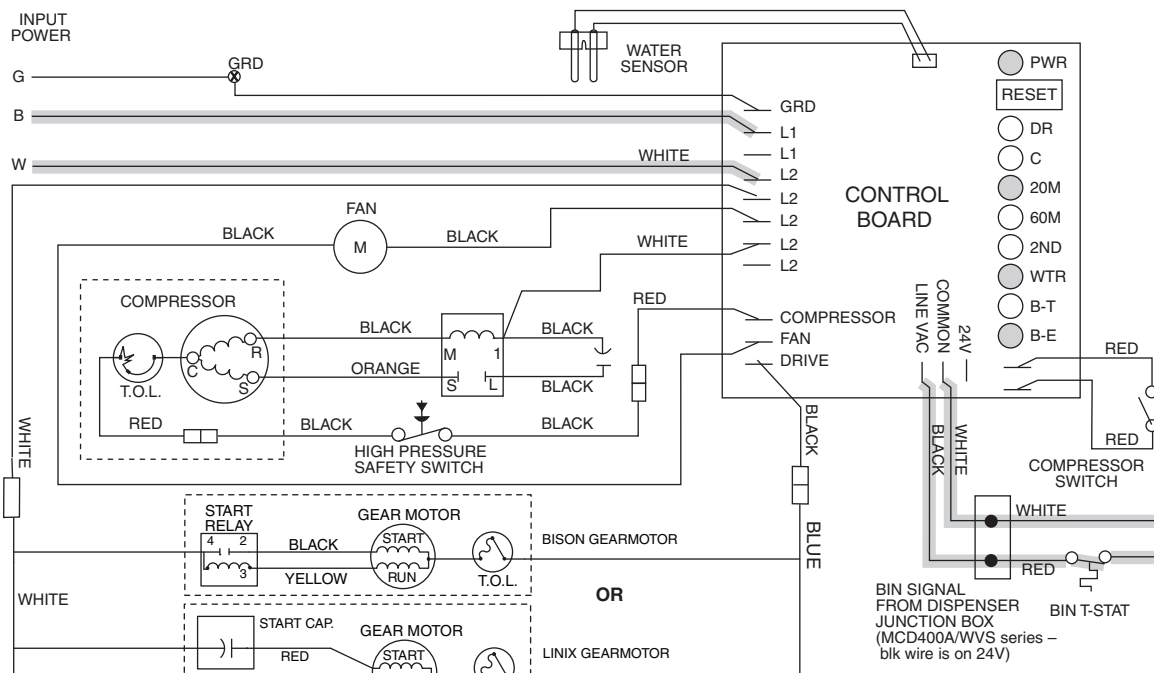

### Diagnostic sequence – Stage 8

If the restart is successful the 20M LED goes off, the 60 minute timer LED (60M) comes on. The 60M LED will remain on for 60 minutes from restart. A lighted 60M LED tells the technician that the ice machine has experienced an over-torque condition. If the ice machine runs without problems for 60 minutes and no additional torque errors occur, the 60M LED will go off and the ice machine will continue normal operation.

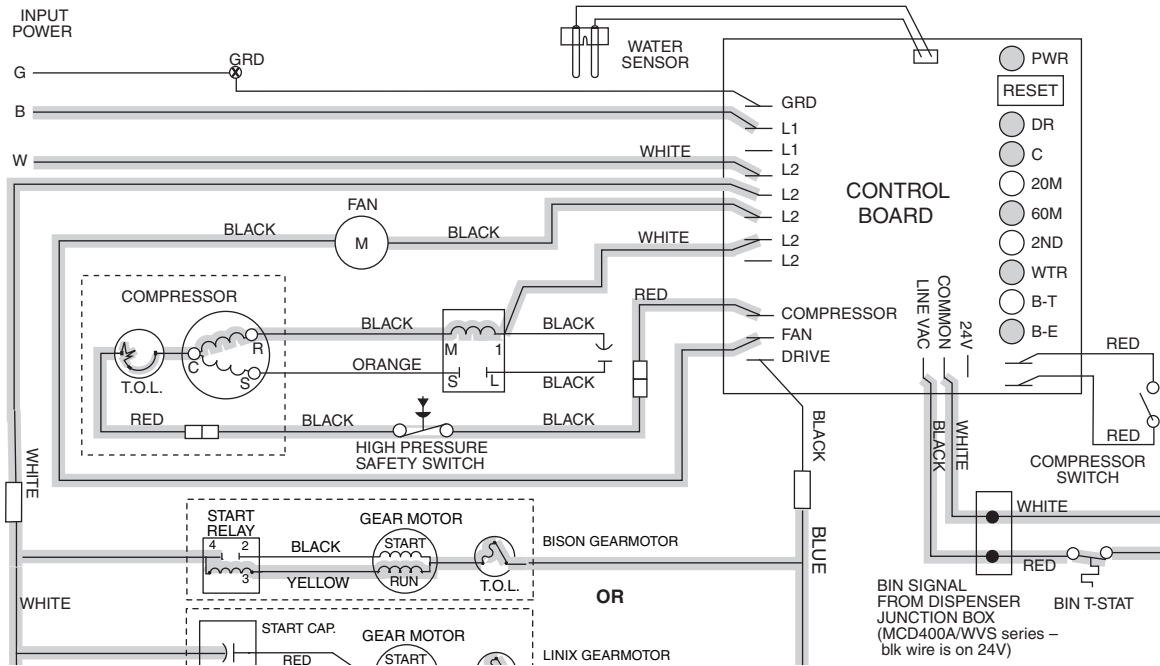

### Diagnostic sequence – Stage 9

The second error (2ND) LED will come on if an over-torque condition occurs while the 60M LED is still lighted. The 2ND LED will indicate to the technician that two consecutive over-torque situations have occurred. The ice machine will shut down at this time and lock out. It will not restart unless the manual reset button is depressed.

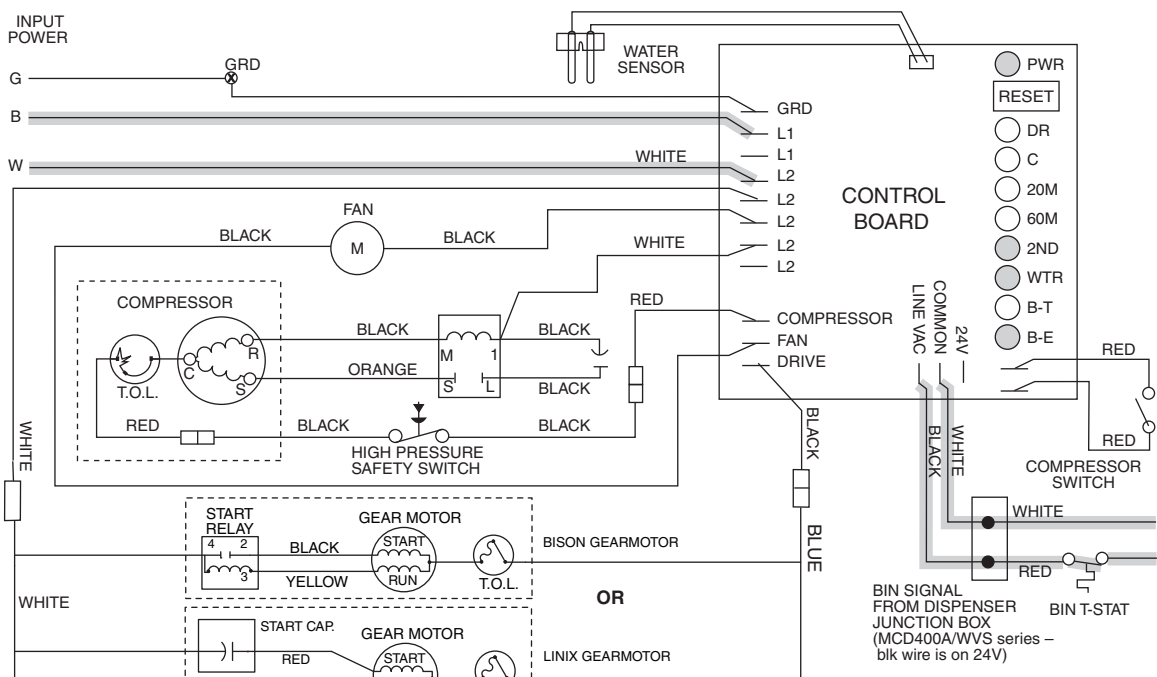

### Diagnostic sequence – Stage 10

If the water level in the float reservoir drops to an unacceptable level, the WTR LED will go out, shutting the ice machine off. Also, the BT LED will come on, preventing the ice machine from restarting for twenty minutes. If water is restored, the WTR LED will come back on and flash to alert the technician that water to ice machine has been lost. The ice machine will then restart at the end of the 20 minute time delay. The flashing WTR LED can be cleared by pressing the reset button.

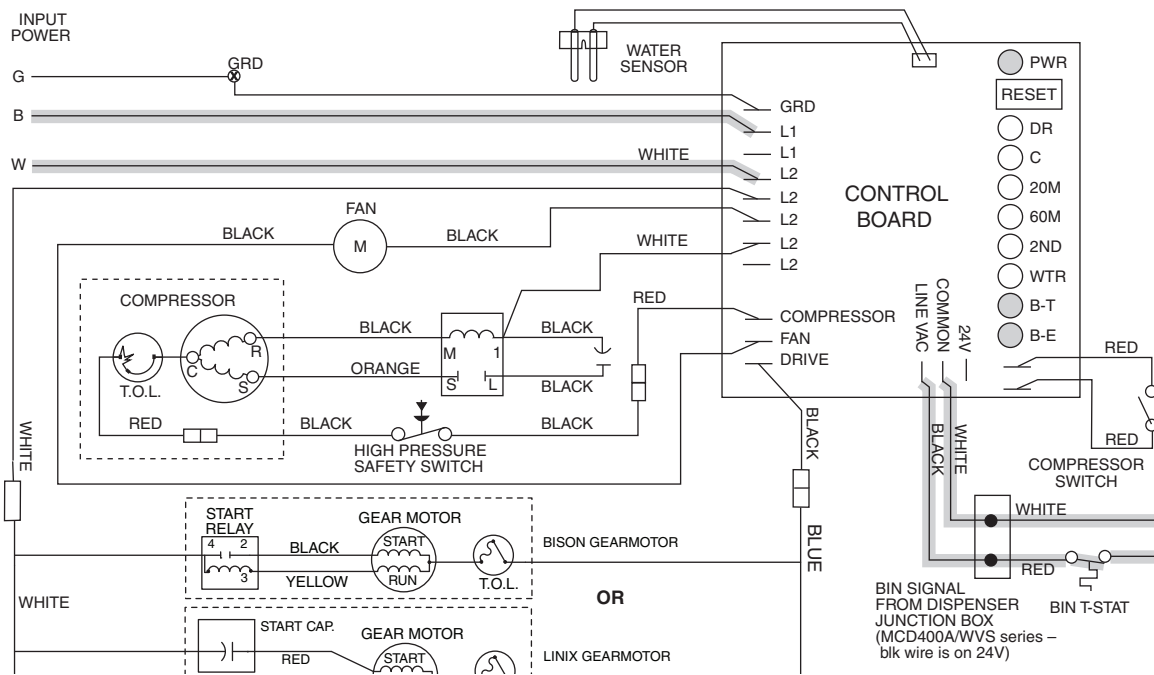

## Refrigeration system (all models)

All service on refrigeration systems must be performed in accordance with all federal, state and local laws. It is the responsibility of the technician to ensure that these requirements are met. Recharging ice machine to other than factory specifications will void the warranty.

R404A ice machine charge specifications		
Model	Charge	Refrigerant type
T400A, MCD400A, MFD400A, R400A, D400A (air-cooled)	19 oz. (539 g)	R404A
T400W, MCD400W, MFD400W, R400W, D400W (water-cooled)	9 oz. (255 g)	R404A

### Refrigerant replacement requirements

1. Non-contaminated refrigerant removed from any Follett refrigeration system can be recycled and returned to the same system after completing repairs. Recycled refrigerant must be stored in a clean, approved storage container. If additional refrigerant is required, virgin or reclaimed refrigerant that meets ARI standard 700-88 must be used.
2. In the event of system contamination (for example, a compressor burn out, refrigerant leak, presence of non-condensibles or moisture), the system must be repaired, evacuated and recharged using virgin or reclaimed refrigerant that meets ARI standard 700-88.
3. Follett Corporation does not approve of recovered refrigerants. Improper refrigeration servicing procedures will void the factory warranty.

### Evacuation

Evacuate the system to a level of 500 microns. When the 500 micron level is reached, close valves and both manifold and shut down the vacuum pump. Allow the system to sit for approximately 20 minutes. During this period the system pressure should not rise. If the system pressure rises and stabilizes there is moisture in the system and further evacuation is needed. If the pressure continues to rise check the system for leaks.

Ambients	Minimum	Maximum
Air temperature <sup>1</sup>	50 F/10 C	100 F/37.8 C
Water temperature <sup>2</sup>	40 F/4.4 C	90 F/32.2 C

<sup>1</sup>Ambient air temperature is measured at the air-cooled condenser coil inlet.

<sup>2</sup>Ambient water temperature is measured in the ice machine float reservoir.

### Ice capacity test

Ice machine production capacity can only be determined by weighing ice produced in a specific time period.

1. Replace all panels on ice machine.
2. Run ice machine for at least 15 minutes.
3. Weigh and record weight of container used to catch ice.
4. Catch ice for 15 or 20 minutes.
5. Weigh harvested ice and record total weight.
6. Subtract weight of container from total weight.
7. Convert fractions of pounds to decimal equivalents (ex. 6 lb 8 oz. = 6.5 lb).
8. Calculate production using following formula:

$$\frac{1440 \text{ min.} \times \text{wt. of ice produced}}{\text{Total test time in minutes}} = \text{Production capacity/24 hr. period}$$

9. Calculated amount per 24 hours should be checked against rated capacity for same ambient and water temperatures in Ice Production Tables.

## Service procedures

### Evaporator disassembly (Fig. 7)

1. Disconnect power to ice machine.
2. Shut off water to ice machine.
3. Drain evaporator and float tank.
4. Disconnect plastic tubing from evaporator water inlet, drain pan stub, compression nozzle tubing and reservoir overflow tubing from secured clip.
5. Disconnect ice transport tube from compression nozzle.  
**Note:** No compression nozzle on MFD400 series flake ice machines.
6. Loosen nut and remove upper vee band coupling from top of evaporator.
7. Lift top bearing assembly straight up with a slight rotating motion and remove.
8. Remove ice compression loop located at top of auger.
9. Lift auger straight up and out of evaporator.
10. Remove nut and lower vee band coupling from bottom of evaporator.
11. Lift evaporator to clear bottom bearing assembly.
12. Loosen hex head bolt in side of mounting base with 5/16 wrench and lift lower bearing assembly.
13. Remove condensate shield.
14. Remove 4 Allen head machine screws holding mounting base to gearbox.
15. If replacing evaporator, remove compression nozzle from evaporator port.

### Evaporator reassembly (Fig. 7)

1. Clean gearmotor boss, output shaft and shaft well.
2. Install drain pan and evaporator mounting base.
3. Fill gearmotor shaft well with food-grade grease (Fig. 8).
4. Install condensate shield and seat against gearmotor boss.
5. Install mounting base O ring in groove in evaporator mounting base.
6. Lower bottom bearing assembly into evaporator mounting base.
7. While maintaining a downward pressure on bottom bearing assembly, tighten hex head bolt with a 5/16 wrench.
8. Position evaporator over lower bearing assembly and align grooves with pins in bearing assembly.
9. Install vee band clamp and nut and tighten to 70 in/lb.
10. Place auger in center of evaporator and rotate to mate with drive pin.
11. Install ice compression loop, orienting loop as shown in Fig. 7.  
**Note:** No compression nozzle on MFD400 series flake ice machines.
12. Install upper bearing and seal assembly, rotating bearing to slip pin into auger slot.
13. Install upper vee band clamp and nut and tighten to 70 in/lb.
14. If evaporator was replaced, reinstall compression nozzle.

### Gearmotor replacement (Fig. 8)

1. Disassemble evaporator as described above.
2. Disconnect the wire connectors.
3. Remove 4 screws holding gearmotor mounting plate to base of ice machine and lift gearbox and motor clear of ice machine (Fig. 8.1).
4. Remove machine screws holding mounting plate to motor (Fig. 8.2).
5. Install new motor in reverse order.

Fig. 7

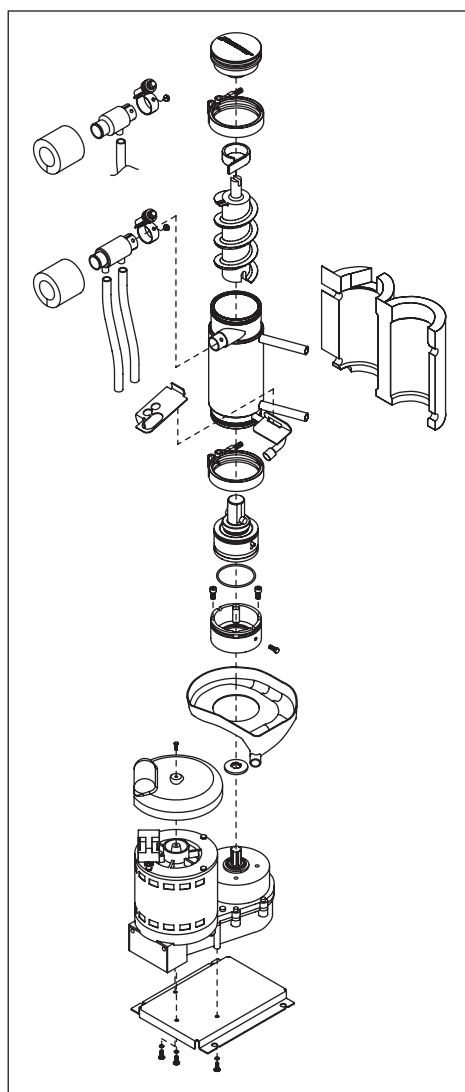
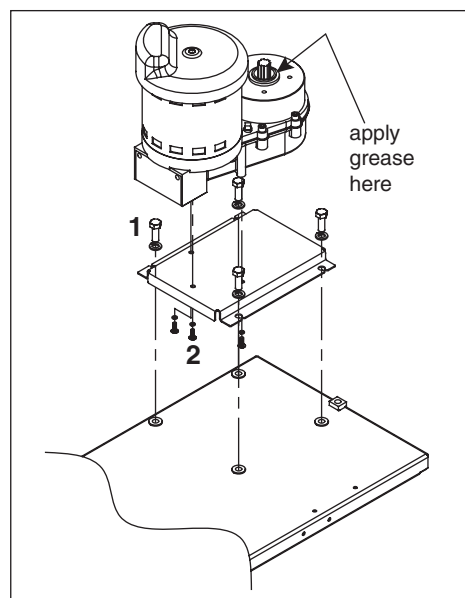

Fig. 8



# Ice machine troubleshooting

Flashing water LED at any time indicates that water signal to board had been lost for more than one second.

Ten-second delay: There is a 10 second delay in reaction to loss of water (WTR) or bin (B-E) signals. If signals are not lost for more than 10 seconds, no reaction will occur.

Problem	Indicators	Corrective Action
Ice machine will not run.  System status: compressor, gearmotor, and fan motor inoperative.	<ol style="list-style-type: none"> <li>1. No power to unit.</li> <li>2. Open bin level control.</li> <li>3. Water OK LED (WTR) not on.</li> <li>4. 20M or 2ND LED is on indicating that first or second torque error has occurred.</li> <li>5. Gear motor locked up (immediate torque error indicated by LEDs when board is reset).</li> <li>6. Open coil on gearmotor start relay causing an immediate torque error.</li> </ol>	<ol style="list-style-type: none"> <li>1. Check that unit is plugged in, circuit breakers are on.</li> <li>2. Adjust or replace ice level control.</li> <li>3. Check reservoir for water, restore water to unit.</li> <li>4. See #6 below.</li> <li>5. Repair or replace gearmotor.</li> <li>6. Replace gearmotor start relay.</li> </ol>
Compressor will not run.  System status: gearmotor and fan motor run.	<ol style="list-style-type: none"> <li>1. Condenser coil plugged causing open overload or high pressure cut-out.</li> <li>2. Defective starting capacitor.</li> <li>3. Defective starting relay.</li> <li>4. Open motor winding.</li> <li>5. No power output from compressor output terminal on control board.</li> </ol>	<ol style="list-style-type: none"> <li>1. Clean condenser coil and replace overload if necessary.</li> <li>2. Replace start capacitor.</li> <li>3. Replace relay.</li> <li>4. Ohm out windings and replace compressor if necessary.</li> <li>5. Check terminal connection and replace control board if necessary.</li> </ol>
Unit cycles intermittently.  System status: compressor, gearmotor, and fan motor cycle.	<ol style="list-style-type: none"> <li>1. Float reservoir running dry, sensing probe signalling for system to shut down.</li> </ol>	<ol style="list-style-type: none"> <li>1. Check water supply to float and float operation. PC board will have flashing WTR LED.</li> </ol>
Low ice production.  Poor quality ice.	<ol style="list-style-type: none"> <li>1. Dirty air filter or condenser coil.</li> <li>2. Restricted air flow to condenser coil.</li> <li>3. Mineral coated evaporator.</li> <li>4. Improper exhaust air provisions.</li> <li>5. Faulty expansion valve.</li> <li>6. Low refrigerant charge.</li> <li>7. Superheat incorrect.</li> <li>8. Inefficient compressor.</li> </ol>	<ol style="list-style-type: none"> <li>1. Clean or replace filter, clean condenser.</li> <li>2. Remove obstruction.</li> <li>3. Clean evaporator.</li> <li>4. Provide proper exhaust air provisions per Follett installation manual.</li> <li>5. Replace expansion valve.</li> <li>6. Check for leaks; repair, evacuate, and weigh in correct charge.</li> <li>7. Check that TXV sensing bulb is securely clamped in place and not damaged; check that insulated bulb cover is in place.</li> <li>8. Replace compressor.</li> </ol>
Water leaks from bottom of evaporator.	<ol style="list-style-type: none"> <li>1. O ring seal broken.</li> </ol>	<ol style="list-style-type: none"> <li>1. Replace O ring.</li> </ol>
Ice machine runs for short period of time and shuts down on torque error.  System status: 20M or 2nd LED is lit.	<ol style="list-style-type: none"> <li>1. Kink in ice transport tube.</li> <li>2. Bin level control remains in closed position.</li> <li>3. Ice transport tube ruptured internally.</li> <li>4. Worn evaporator bearings.</li> <li>5. Faulty gearmotor start relay. Ice machine torques out within 5 seconds of start-up.</li> <li>6. Torque out occurs when storage bin fills to capacity.</li> </ol>	<ol style="list-style-type: none"> <li>1. Eliminate kink and check that tube routing complies with Follett ice machine installation manual.</li> <li>2. Adjust or replace control.</li> <li>3. Replace complete length of ice transport tube.</li> <li>4. Inspect bearings for roughness or binding and replace if necessary.</li> <li>5. Replace gearmotor start relay.</li> <li>6. Ensure that ice contacts bin thermostat before backing ice up in transport tube. Refer to dispenser manual for proper thermostat and ice tube mounting.</li> </ol>
Evaporator is iced up on the outside. No ice production.  System status: compressor, gearmotor and fan motor running.	<ol style="list-style-type: none"> <li>1. Gearmotor running but no output rotation.</li> <li>2. Float reservoir empty.</li> <li>3. Air bubble in water supply line. Water in reservoir but not in evaporator.</li> </ol>	<ol style="list-style-type: none"> <li>1. Check for broken gearmotor output shaft or damaged gearbox.</li> <li>2. Check for defective water sensor (water OK (WTR) LED remains on even when float empty or probe removed from water).</li> <li>3. Purge air from line.</li> </ol>

<b>Problem</b>	<b>Indicators</b>	<b>Corrective Action</b>
Compressor cycles intermittently. System status: garmotor and fan motor run.	<ol style="list-style-type: none"> <li>1. Compressor start relay in wrong position.</li> <li>2. High pressure cutout open due to high head pressure.</li> <li>3. Clogged or dirty air filter or condenser coil.</li> <li>4. Improper ventilation.</li> <li>5. Defective compressor.</li> </ol>	<ol style="list-style-type: none"> <li>1. Position relay with arrow or word "top".</li> <li>2. Check discharge pressure and adjust water regulator valve.</li> <li>3. Clean or replace filter, clean condenser coil.</li> <li>4. Provide inlet and exhaust air provisions per Follett ice machine installation manual.</li> <li>5. Replace compressor.</li> </ol>
Unit runs but not making ice. System status: compressor, gearmotor & fan motor running.	<ol style="list-style-type: none"> <li>1. Clogged or dirty air filter or condenser coil.</li> <li>2. Compressor not pumping.</li> <li>3. Low refrigerant charge.</li> </ol>	<ol style="list-style-type: none"> <li>1. Clean or replace filter, clean condenser coil.</li> <li>2. Replace compressor.</li> <li>3. Check for leaks; repair, evacuate, and weigh in correct charge.</li> </ol>
Compressor and fan motor will not run. Gearmotor runs.	<ol style="list-style-type: none"> <li>1. Compressor switch in OFF position.</li> <li>2. No output on compressor and fan motor terminals on control board.</li> <li>3. Failed fan motor causes high pressure cut-out to open.</li> </ol>	<ol style="list-style-type: none"> <li>1. Turn compressor switch on.</li> <li>2. Replace control board.</li> <li>3. Replace fan motor.</li> </ol>
Intermittent noises from evaporator.	<ol style="list-style-type: none"> <li>1. Mineral build-up on evaporator surface.</li> </ol>	<ol style="list-style-type: none"> <li>1. Clean evaporator with liquid ice machine cleaner.</li> </ol>

## Evaporator

Reference #	Description	Part #
1	Coupling, vee band, includes nut	502735
2	Bearing assembly, top	502736
3	Loop, ice compression, beveled (see below for Flaker-specific components)	502110
4	Auger (see below for Flaker-specific components)	502737
5	Evaporator (includes insulation jacket, 502740)	502725
6	O ring, bearing housing	500496
7	Bearing assembly, bottom (includes O rings and condensate shield)	502738
8	O ring, mounting base	501063
9	Shield, condensate	500744
10	Screw, Allen 1/4 20 x 1/2 (set of 4)	501080
11	Mounting base, evap. (includes 501063)	502733
12	Bolt, mounting base	502227
13	Gearbox & motor (includes 307192)	502730
Not shown	Mounting base, gearbox	502729
15	Compression nozzle, with single drain	502221
16	Drain pan, evaporator	502727
17	Clamp, compression nozzle and screw	502226
18	Tubing, compression nozzle drain(s) (sold by foot)	500680
Not shown	Grease, Chevron SRI-2, 14 oz	501111
19	Bracket, drain hose	502739
20	Insulation jacket, evaporator	502740
21	Relay, gearmotor	00142042
22	Cover, metal	502744
22	Cover, black plastic	01012228

## Flaker-specific components

Reference #	Description	Part #
3	Loop, compression, notched	00124115
4	Auger (with paddle)	00124123



# Evaporator

Order parts online  
[www.follettice.com](http://www.follettice.com)

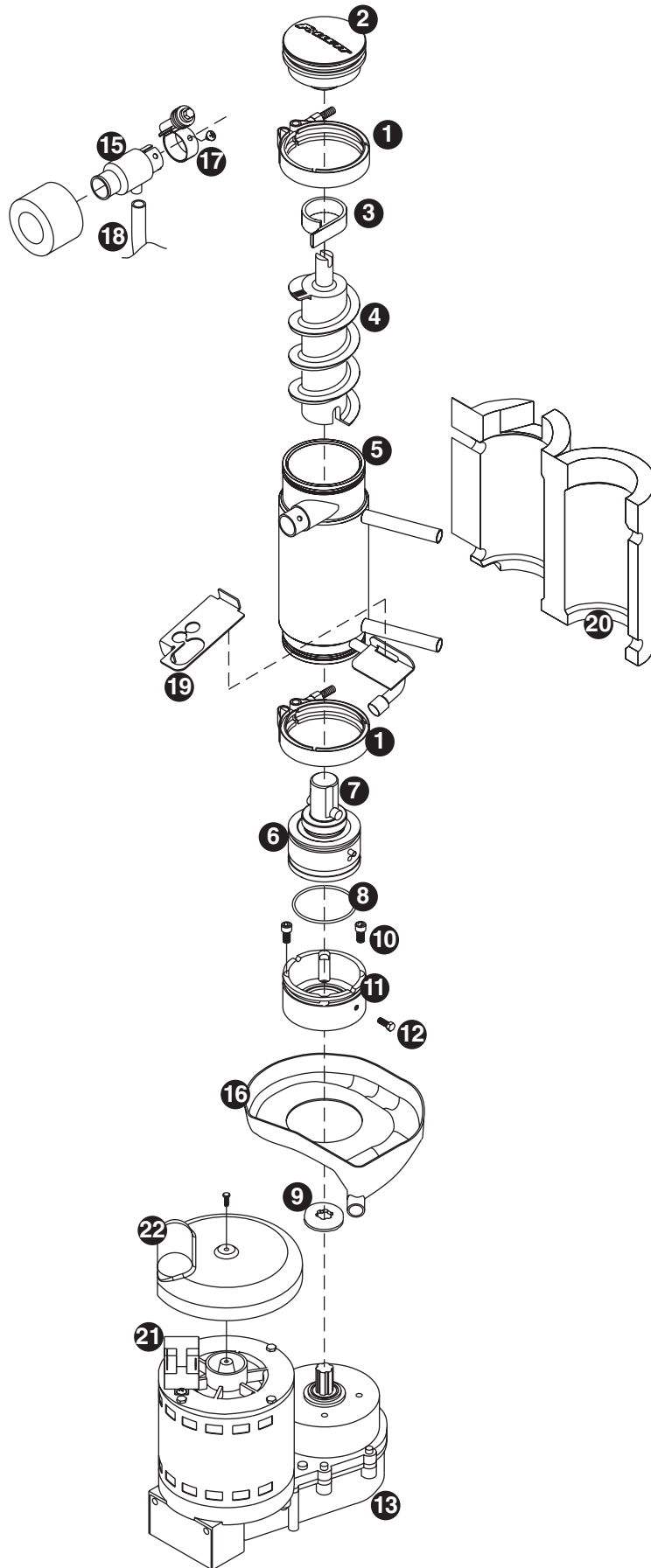

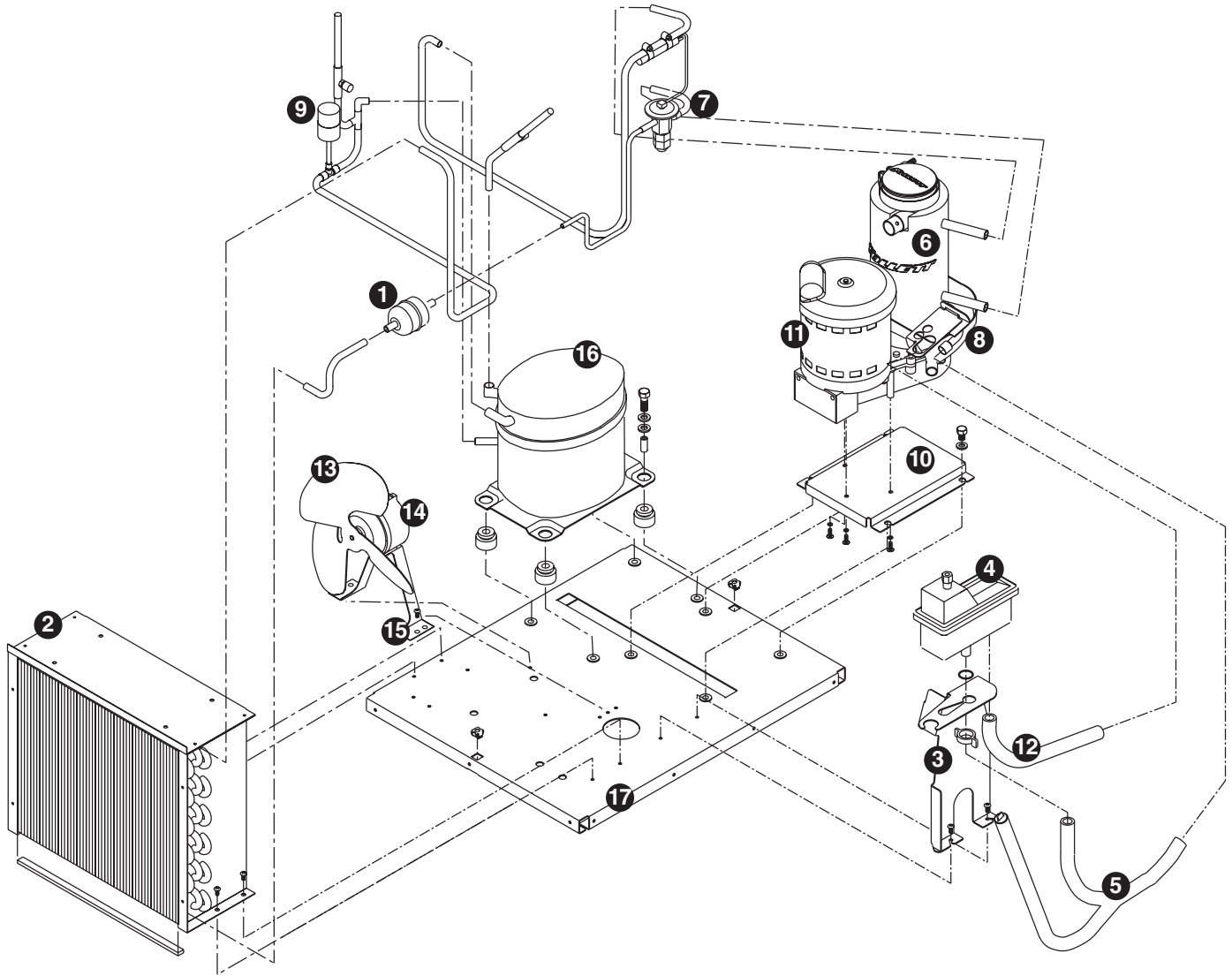

Reference #	Description	Part #
1	Drier	502724
2	Condenser coil, A/C	501187
Not shown	Water sensor	502116
3	Reservoir mounting bracket	501986
4	Float valve & reservoir	500504
5	Drain kit with Agion, evaporator	00141440
6	Evaporator (see page 32 and 33 for complete breakdown)	—
Not shown	Tubing, polypropylene, reservoir supply (sold by foot)	502079
Not shown	Fitting, plastic, float valve (includes sleeve & stem)	502078
Not shown	Compression nozzle, with double drain	502220
Not shown	Compression nozzle, with single drain	502221
7	Valve, expansion, thermal	502726
8	Drain pan, evaporator	502727
9	High pressure cutout	502732
Not shown	Tubing, evaporator drain, 3/4" (19 mm) ID x 1" (26 mm) OD (sold by the foot)	501966
10	Mounting bracket, gearbox	502729
11	Gearbox & motor assembly, 115 V, 60 Hz	502730
12	Tubing, plastic, food grade, 1/2" (13mm) ID (sold by foot)	501191
13	Fan blade	500474
14	Motor, fan, 115 V, 60 Hz	500672
15	Bracket, fan motor	501188
Not shown	Overload, compressor, 115 V, 60 Hz	502782
16	Compressor, 115 V, 60 Hz	502731
17	Base – L400A	502728
Not shown	Strainer, water, threaded connections	500376
Not shown	Strainer, push-in connections	502920
Not shown	Shroud, condenser coil	501820
Not shown	Water inlet & drain assembly, brass	502734
Not shown	Water inlet fitting, plastic	502924
Not shown	Water inlet elbow, plastic	502925
Not shown	Drain fitting, plastic	00109728
Not shown	Jacket, insulation, TXV	502830
Not shown	Bracket, ice tube entry	502698
Not shown	Pinch clamp	00988238

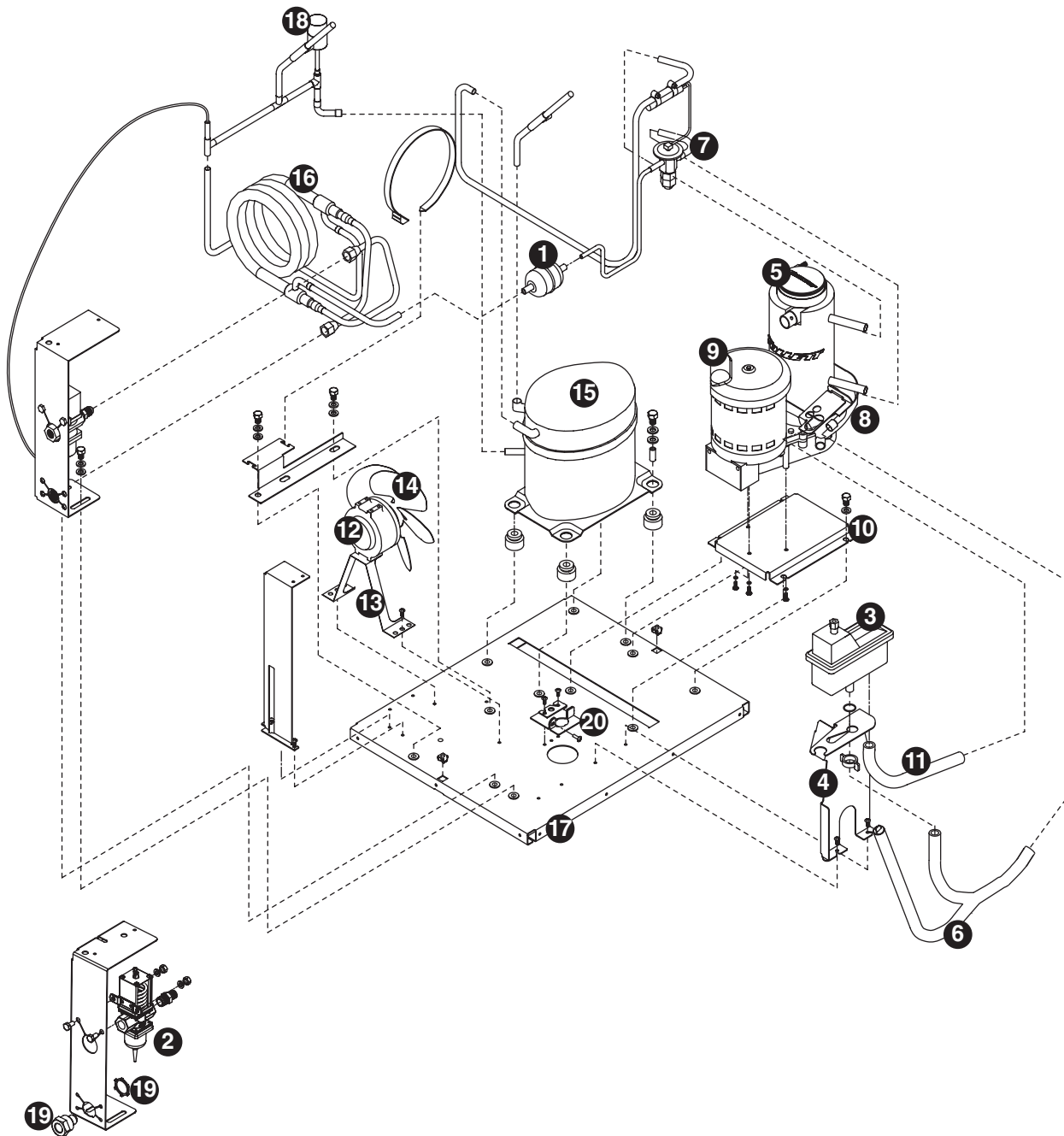

Reference #	Description	Part #
1	Drier	502724
2	Valve, water regulating (includes Iso-washer)	500537
Not shown	Iso-washer (for water regulating valve)	501810
Not shown	Water sensor	502116
3	Float valve & reservoir	500504
4	Reservoir mounting bracket	501986
Not shown	Tubing, polypropylene, reservoir supply (sold by foot)	502079
Not shown	Fitting, plastic, float valve (includes sleeve & stem)	502078
Not shown	Compression nozzle, with double drain	502220
Not shown	Compression nozzle, with single drain	502221
5	Evaporator (see page 32 and 33 for complete breakdown)	—
6	Drain kit with Agion, evaporator	00141440
7	Valve, expansion, thermal	502726
8	Drain pan, evaporator	502727
Not shown	Tubing, evaporator drain, 3/4" (19mm) ID x 1" (26 mm) OD (sold by foot)	501966
9	Gearbox & motor assembly, 115 V, 60 Hz	502730
10	Mounting bracket, gearbox	502729
11	Tubing, plastic, food grade, 1/2" (13 mm) ID (sold by foot)	501191
12	Motor, fan, 115V, 60Hz	500672
13	Bracket, fan motor	501188
14	Fan blade	500790
Not shown	Overload compressor, 115 V, 60 Hz	502782
15	Compressor, 115 V, 60 Hz	502731
16	Coil, condenser	00111898
17	Base, L400W	502741
Not shown	Strainer, water, threaded connections	500376
Not shown	Strainer, push-in connections	502920
Not shown	Water inlet and drain assembly, brass	502734
Not shown	Water inlet fitting, plastic	502924
Not shown	Water inlet elbow, plastic	502925
Not shown	Drain fitting, plastic	00109728
Not shown	Assembly, drain, single fitting	502348
18	High pressure cutout	502732
Not shown	Jacket, insulation, TXV	502830
19	Fitting, condenser drain	00143941
20	Bracket, ice tube entry	502698
Not shown	Pinch clamp	00988238

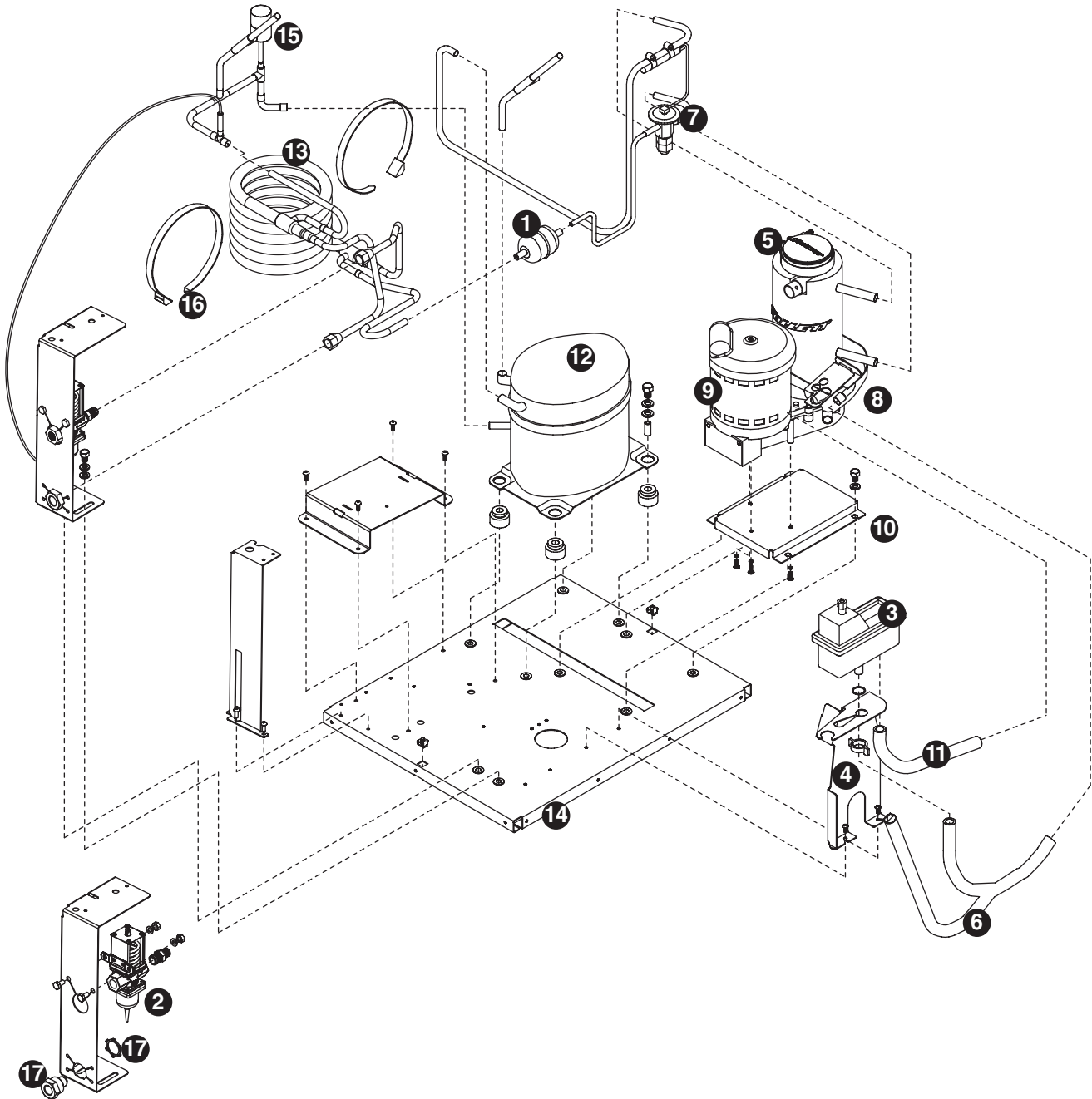

Reference #	Description	Part #
1	Drier	502724
2	Valve, water regulating (includes Iso-washer)	500537
Not shown	Iso-washer (for water regulating valve)	501810
Not shown	Water sensor	502116
3	Float valve & reservoir	500504
4	Reservoir mounting bracket	501986
Not shown	Tubing, polypropylene, reservoir supply (sold by foot)	502079
Not shown	Fitting, plastic, float valve (includes sleeve & stem)	502078
Not shown	Compression nozzle, with double drain	502220
Not shown	Compression nozzle, with single drain	502221
5	Evaporator (see page 32 and 33 for complete breakdown)	—
6	Drain kit with Agion, evaporator	00141440
7	Valve, expansion, thermal	502726
8	Drain pan, evaporator	502727
Not shown	Tubing, evaporator drain, 3/4" (19 mm) ID x 1" (26 mm) OD (sold by foot)	501966
9	Gearbox & motor assembly, 115 V, 60 Hz	502730
10	Mounting bracket, gearbox	502729
11	Tubing, plastic, food grade, 1/2" (13mm) ID (sold by foot)	501191
Not shown	Overload compressor, 115 V, 60 Hz	502782
12	Compressor, 115 V, 60 Hz	502731
13	Coil, condenser	00195933
14	Base, L400W	502741
Not shown	Strainer, water, threaded connections	500376
Not shown	Strainer, push-in connections	502920
Not shown	Water inlet and drain assembly, brass	502734
Not shown	Water inlet fitting, plastic	502924
Not shown	Water inlet elbow, plastic	502925
Not shown	Drain fitting, plastic	00109728
Not shown	Assembly, drain, single fitting	502348
15	High pressure cutout	502732
Not shown	Jacket, insulation, TXV	502830
16	Ty-rap (2 required)	204584
17	Fitting, condenser drain	00143941
Not shown	Bracket, ice tube entry	502698
Not shown	Pinch clamp	00988238

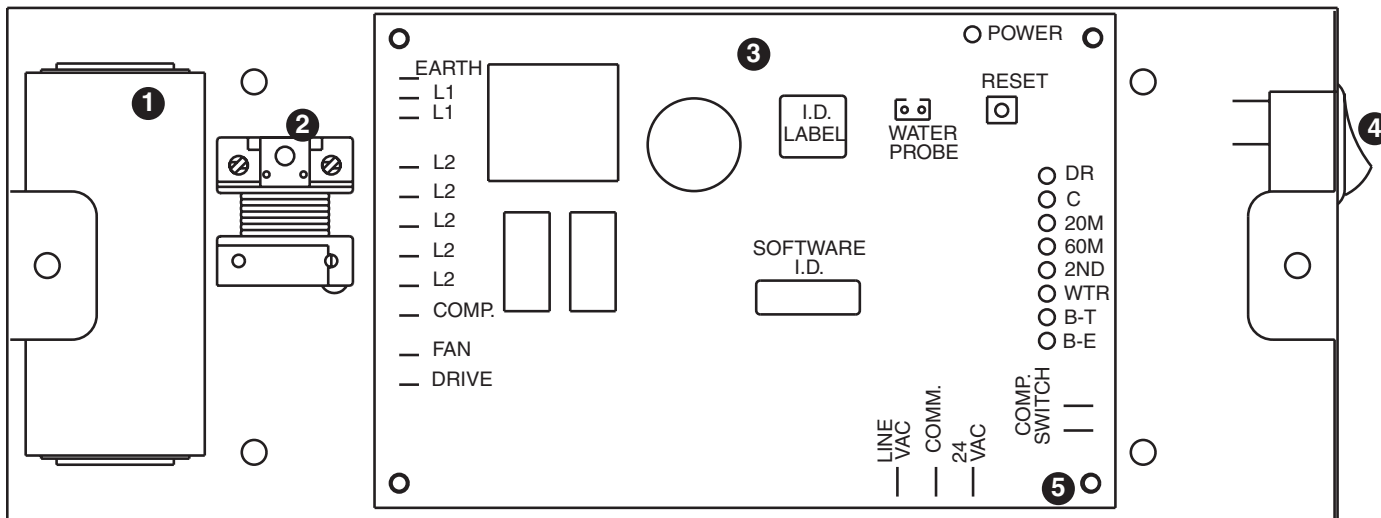

Reference #	Description	Part #
1	Capacitor, start, compressor, 115 V, 60 Hz	502780
2	Relay start, compressor, 115 V, 60 Hz	501588
3	Board, control circuit, 115 V, 60 Hz	502331
Not shown	Water sensor	502116
4	Switch, on/off, compressor	502392
Not shown	Bin thermostat (MCD400A/WBT, MCD400A/WHT, MFD400A/WBT and MFD400A/WHT only)	500514
5	Board, stand off control (4 required)	501959



**Ice machine cleaner/descaler**

00132001	SafeCLEAN environmentally-friendly cleaner, carton of 24 x 7 oz packets
----------	---

**Ice machine sanitizer**

00979674	Nu-Calgon IMS-II Sanitizer, 16 oz. bottle
----------	---

**Miscellaneous**

Part #	Description
501860	Condensate pump
502775	Oil, gearmotor, 1 pint
501111	Grease, Mobile FM 222, 14 oz tube
500377	Clamp, ice tube
501921	Grommet, ice tube
502783	Duct – 2" (51mm)
502781	Gasket, air duct
501425	Grille
501986	Bracket, float mounting
501759	Cord and plug (female), dispenser bin signal (F1105A/W)
501858	Cord and plug (female), dispenser power (all 25, 50, 110 series dispensers)
501786	Cord and plug (female), dispenser bin signal (all 25 and 50 series top mount and freestanding dispensers)
501702	Control board adapter (R404A to R12)
502051	Cord and twist-lock plug (male), ice machine bin signal
502052	Cord and twist-lock plug (male), ice machine power
502333	Plug, twist-lock, two lead, male
502334	Plug, twist-lock, two lead, female
502235	Plug, twist-lock, three lead, male
502336	Plug, twist-lock, three lead, female
502794	Panel, right hand, louvered, R400A, MCD400A/W
502795	Cover, top, R400A/W, MCD400A/W
502796	Panel, front utility, R400A, MCD400A
502797	Panel, top front, R400A, MCD400A
502798	Panel, left hand & rear, R400A/W, MCD400A/W
502799	Panel, front, R400W, MCD400W
502800	Filler, base, R400A/W, MCD400A/W
502801	Condenser, L400W
502802	Power cord, R400, MCD400
502803	Bin signal cord, R400, MCD400
502874	Grille, condenser, T400A and MCD400AHT
502875	Filter, air, T400A and MCD400AHT
00918045	Assembly, front cover

**Water treatment accessories for Symphony ice and water dispensers**

Reference #	Description	Part #
<b>Standard capacity filter system</b>		
Not shown	Follett QC4-FL4S water filter system (includes FL4S primary cartridge and head, coarse pre-filter and head, pressure gauge, flushing valve; assembled and installed on mounting bracket), one per ice machine	00130229
Not shown	Follett FL4S primary replacement cartridge	00130245
Not shown	Water filter cartridge – primary, carton of 6	00954297
Not shown	Everpure coarse pre-filter cartridge	00130211
Not shown	Water pre-filter cartridge – pre-filter, carton of 12	00954305
<b>High capacity filter system</b>		
Not shown	High capacity water filter system (one per ice machine)	00978957
Not shown	High capacity water filter cartridge – primary, single	00978965
Not shown	High capacity water filter cartridge – primary, carton of 6	00978973
Not shown	Water pre-filter cartridge – pre-filter, single	00130211
Not shown	Water pre-filter cartridge – pre-filter, carton of 12	00954305
<b>Carbonless high capacity filter system</b>		
Not shown	Carbonless high capacity water filter system (one per ice machine) – Horizon and Maestro series ice machines	01050442
Not shown	Carbonless high capacity water filter cartridge – primary, single	01050426
Not shown	Carbonless high capacity water filter cartridge – primary, carton of 6	01050434
Not shown	Water pre-filter cartridge – pre-filter, single	00130211
Not shown	Water pre-filter cartridge – pre-filter, carton of 12	00954305
<b>Other filtration</b>		
Not shown	Claris hardness removal filtration system	00986059
Not shown	Replacement filter for Claris system	00985127
Not shown	Reverse osmosis system, 200 gallons per day	00986034
Not shown	Replacement reverse osmosis cartridge	00985085
Not shown	Replacement reverse osmosis pre-filter	00985077
Not shown	Cleaning plug for reverse osmosis system	00985119
Not shown	Cleaning cartridge for reverse osmosis system	00985101
<b>Water pressure</b>		
Not shown	Water pressure regulator (25 psi)	501781

**Dispenser models**

**Replacement  
ice machine model**

**Dispensers with top mounted ice machines**

50CT400A & 50HT400A	D400A
50HT400W & 50HT400W	D400W
25CT 400A & 25HT400A	D400A
25CT400W & 25HT400W	D400W
110CT400A	D400A
110CT400W	D400W

**Dispensers with remote ice machines**

25CR400A & 25HR400A	R400A
25CR400W & 25HR400W	R400W
50CR400A & 50HR400A	R400A
50CR400W & 50HR400W	R400W
110CR400A	R400A
110CR400W	R400W
All U150/VU155 series with air-cooled ice machines	MCD400A
All U150/VU155 series with water-cooled ice machines	MCD400W
All VU300 series with air-cooled ice machines	MCD400A
All VU300 series with water-cooled ice machines	MCD400W

**Dispenser models**

**Replacement  
ice machine model**

**Freestanding dispensers with ice machines in the base**

25FB400A	D400A
25FB400W	D400W
50FB400A	D400A
50FB400W	D400W
110FB400A	D400A
110FB400W	D400W

**Nugget ice machine on top of bin**

MCD400ABT	MCD400ABT
MCD400WBT	MCD400WBT

**Flake ice machine on top of bin**

MFD400ABT	MFD400ABT
MFD400WBT	MFD400WBT

Harmony, SafeCLEAN, Symphony and Vision are trademarks of Follett Corporation.

Chewblet, RIDE and Follett are registered trademarks, and Horizon is a trademark of Follett Corporation, registered in US.



801 Church Lane • Easton, PA 18040, USA  
Toll free (877) 612-5086 • +1 (610) 252-7301  
[www.follettice.com](http://www.follettice.com)



208600R22

© Follett Corporation 2/14