

15CI100A

Welcome to Follett

Follett equipment enjoys a well-deserved reputation for excellent performance, long-term reliability and outstanding after-the-sale support. To ensure that this equipment delivers that same degree of service, review this guide carefully before you begin your installation.

Should you need technical help, please call our Technical Service group at (877) 612-5086 or (610) 252-7301.

Please have your model number, serial number and complete and detailed explanation of the problem when contacting Technical Service.

Getting Started

After uncrating and removing all packing material, inspect the equipment for concealed shipping damage. All freight is to be inspected upon delivery. If visible signs of damage exist, please refuse delivery or sign your delivery receipt "damaged." Follett Customer Service must be notified within 48 hours. Wherever possible, please include detailed photos of the damage with the original packaging so that we may start the freight claim process.

Contents

Welcome	3
Before You Begin	3
Important Safety Information	4
Specifications	4
Dimensions.....	4
Ambient Information.....	4
Plumbing.....	4
Specifications	5
Water.....	5
Clearances.....	5
Electrical.....	5
Refrigeration.....	5
Heat Rejection.....	5
E15 Series Detailed Drawing.....	6
Installation	7
Countertop Installation.....	7
Maintenance/Cleaning Mode	9
Accessing Internal Components	9
Filter Display Indicator Activation	10
NSF-approved Cleaning and Sanitizing Procedure	11
Service	13
LED Indicator Description.....	13
Evaporator Disassembly.....	14
Evaporator Assembly.....	17
Water Feed Schematic.....	21
Storage Bin Melt Water/Evaporator Feed/Clean Out System Schematic.....	22
Vent System Schematic.....	22
Refrigeration Schematic.....	23
Condenser Fan Motor Removal (7 Series Shown).....	24
User Interface Display Identification.....	25
Electrical Wiring Diagram.....	27
Parts	28
15 Series Exterior.....	28
15 Series Interior.....	30
15 Series Bin Assembly.....	32
Evaporator Assembly.....	34

Before You Begin

If needed, the serial number of your dispenser can be found by removing the drip tray ❶ and locating the serial number label ❷. A QR Code is located on the right hand side of the drip tray ❸. This code allows you to access manuals, technical bulletins, and on-line training related to the 7 Series and 15 Series dispensers.

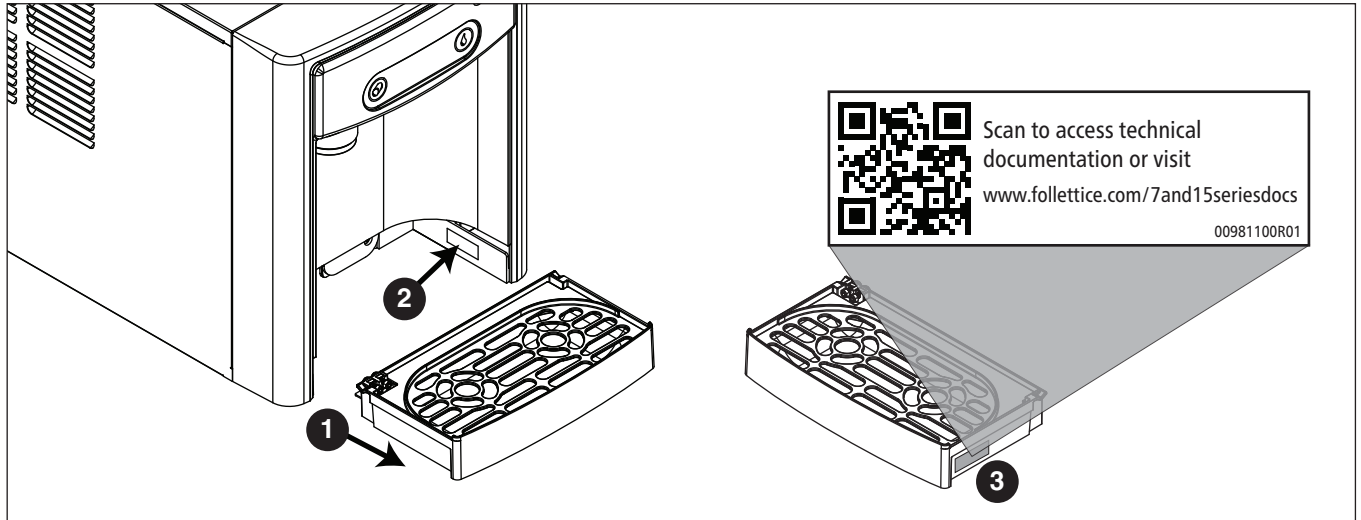

Check your paperwork to verify that you received the correct dispenser. Follett configuration numbers are designed to provide information about the type of dispenser you are receiving. The following is an explanation of the different model numbers.

Dispenser Storage Capacity	Configuration	Icemaker Capacity	Condenser
7 lb (3.1 kg) 15 lb (6.8 kg)	CI Countertop FS Freestanding	100 lbs (45.3 kg) per day	A Air-cooled

Specifications

Dimensions

	15CI100A
Width	14.50" (40 cm)
Depth	23.50" (59.7 cm)
Height	22.50" (57.2 cm)
Unit Shipping Weight	100 lb (45.4 kg)

Ambient Information



CAUTION!

The 15CI100A are for indoor use only. Designed for commercial use. Follett is not able to provide in-house services for residential installations.

	Maximum*	Minimum*
Air Temperature†	100 F (38 C)	50 F (10 C)
Water Temperature	90 F (32.2 C)	40 F (4.5 C)
Water Pressure	70 psi (483 kpa)	10 psi (69 kpa)
Relative Humidity	55% at 78 F (25.5 C)	

* Use outside of these limitations is misuse and will void warranty.
† Best performance is achieved between 80 F (27 C) and 50 F (10 C).

Plumbing

- Water Inlet: 1/4" MPT
- 1/2" bin drain line must slope 1/4" per foot (6 mm per 30.5 cm run)
- Optional Drain Accessory Kit (item# 00956375 or 00981977): 1/2" ID tubing
- Water shut-off recommended within 1.5 m (5 ft) of dispenser

Water



WARNING!

Connect to potable water supply only.

- Water Mineral Content:
 - TDS: greater than 5 ppm (mg/l) but less than 400 ppm (mg/l)
 - Hardness: Less than 200 mg/l (12 gpg)
- Not recommended for use with softened water

Clearances

- 3" (7.62 cm) behind and on each side of dispenser for electrical and connection and ventilation

Electrical

- 115 V, 60 Hz, 1 phase, 5A, maximum fuse 15A
- Connect to dedicated 15A circuit, fuse or breaker
- Must be grounded - requires 3-prong outlet. Do not remove ground.

Refrigeration



WARNING!

Do not damage the refrigerant circuit. Refrigerant can cause personal injury and/or damage dispenser.

- Refrigerant R134a – 5.0 ounces (142 grams)

Heat Rejection

- 1700 BTU/hr (498 W)

15 Series Detailed Drawing

Countertop models

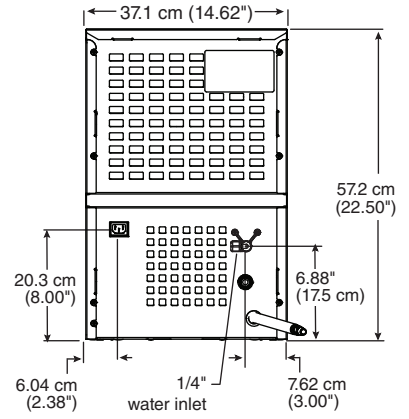
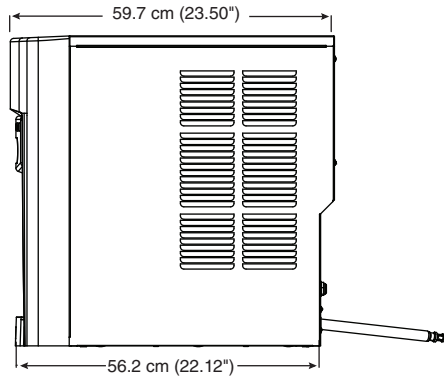
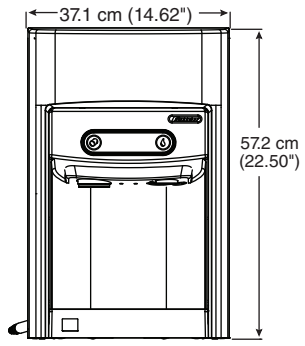

Installation

CAUTION!

No service or maintenance should be performed until the technician has thoroughly read this service manual. Except for routine cleaning and sanitizing, only qualified technicians should attempt to service or maintain this equipment.

Countertop Installation

1. A clearance of at least 3" (7.62 cm) is required behind and on each side of the dispenser for electrical connection and ventilation (**Fig. 1**).
2. Rough-in the electrical service and water line.
 - Electrical: 115 V, single phase, 15A receptacle required. The dispenser has an integral 8 ft (2.4 m) cord and plug.
 - Water: supply line (with shut-off valve) connects to the dispenser's 1/4" MPT inlet.

NOTICE!

If installing optional Drip Tray Drain Kit or Leg Accessory, complete those steps before proceeding.

Fig. 1

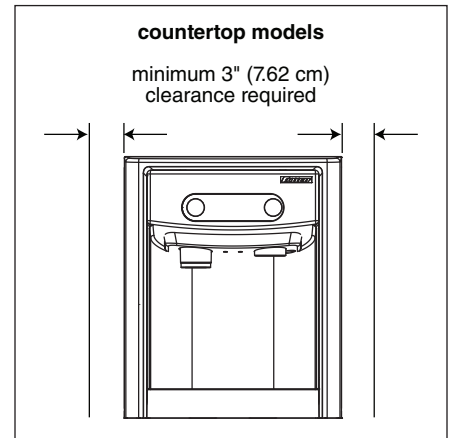

3. Connect water line.
4. Connect to the 1/2" ID drain line (**Fig. 2.1**) (barb fitting provided) and route to customer drain. Drain line must slope 6 mm per 30.5 cm run (1/4" per foot).
5. Install the storage bin drain tube pinch clamp (**Fig. 2.2**). Clamp can be installed externally or internally. To install internally, see [Accessing Internal Components on page 11](#).
6. Connect power supply.
7. Sanitize the dispenser prior to use (see Page 13).

Fig. 2

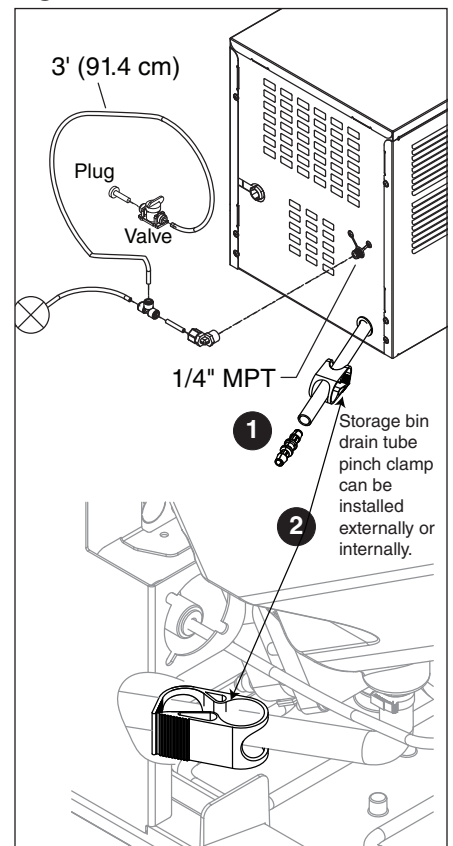

Optional Leg Accessory Installation



CAUTION!

Use caution when tipping the dispenser during leg installation. Do not lay unit on back or side. **DO NOT EXCEED 30°** angle. Tipping more than 30° can result in compressor malfunction.

1. If installing optional 4" Leg Accessory (item# 00956300), place a 5" (12.7 cm) spacer underneath the dispenser to ease installation.
2. Remove four plastic, thread-protecting plugs from bottom of dispenser.
3. Screw each leg into chassis (**Fig. 3**).

Fig. 3

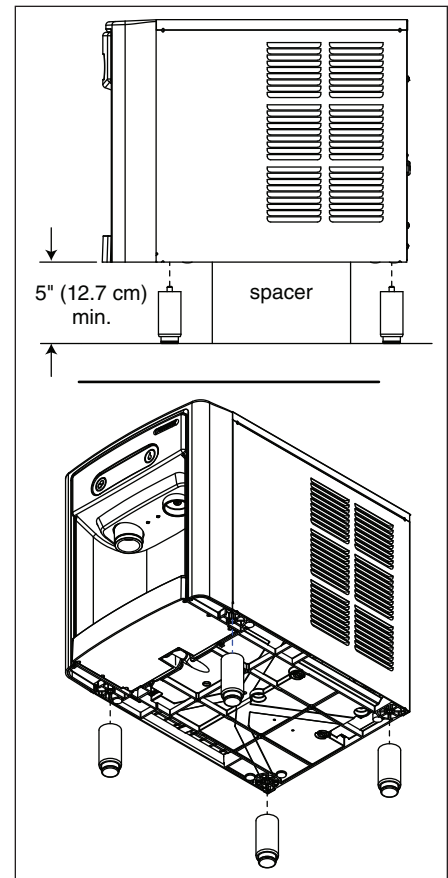

Optional Internal Water Filter Installation

If your dispenser has the internal water filter option, the water filter *must* be installed for the dispenser to operate. Because internal components will need to be accessed for both procedures, Follett recommends installing the water filter just prior to initial sanitizing.

1. If installing the optional internal water filter, please complete the steps shown in [Accessing Internal Components on page 9](#) before proceeding.
2. Lift and remove the top panel, set aside (**Fig. 4.1**).
3. Remove two screws (**Fig. 4.2**) and remove left side panel.
4. Install filter as shown. Turn filter clockwise until it is fully seated (**Fig. 4.3**).

Fig. 4

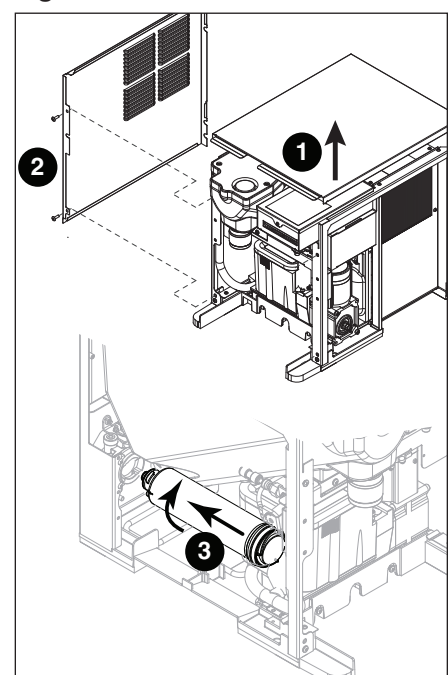

Maintenance/Cleaning Mode



Cleaning Mode (Dispensing Disabled) - Use when cleaning surface

Entering Cleaning Mode disables the User Interface and allows you to clean the outside of the dispenser without accidentally dispensing ice.

1. To enter Cleaning Mode, press and immediately release the maintenance/clean switch (**Fig. 5.1**) so that only "ICE" displays in the user interface (**Fig. 5.2**).
2. To exit Cleaning Mode, press and immediately release the maintenance/clean switch so that the ice icon also displays in the user interface.

Maintenance Mode (All Operations Disabled) - Use when cleaning ice machine

Entering Maintenance Mode disables all operations and allows you to safely clean and/or sanitize the ice machine and dispenser.

1. To enter Maintenance Mode, press and hold the maintenance/clean switch (**Fig. 5.3**) until  displays in the user interface (**Fig. 5.4**).
2. To exit Maintenance Mode, press and hold the maintenance/clean switch until  no longer displays in the user interface.

Note: Entering and exiting Maintenance Mode will reset the six-month periodic maintenance reminder.

Fig. 5

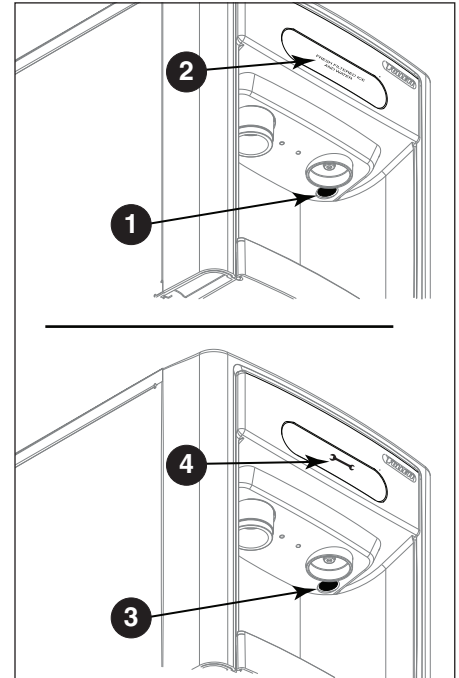

Accessing Internal Components

CAUTION!

Except for routine cleaning and sanitizing, only qualified technicians should attempt to service or maintain this equipment.

1. Press and hold the maintenance/clean switch (**Fig. 5.1**) until  displays in the user interface (**Fig. 5.2**).
2. Remove (unscrew) chrome ice dispenser chute (**Fig. 6.1**).
3. Remove the drip tray (**Fig. 6.2**).
4. Remove the two screws (**Fig. 6.3**) on the front panel (behind the drip tray).
5. Remove and set aside the front panel (**Fig. 6.4**). **Do not disengage the plug on the back of the User Interface.**

Fig. 6



Filter Display Indicator Activation

If you purchased your dispenser with a Follett filter, the filter display indicator activation has been preset at the factory.

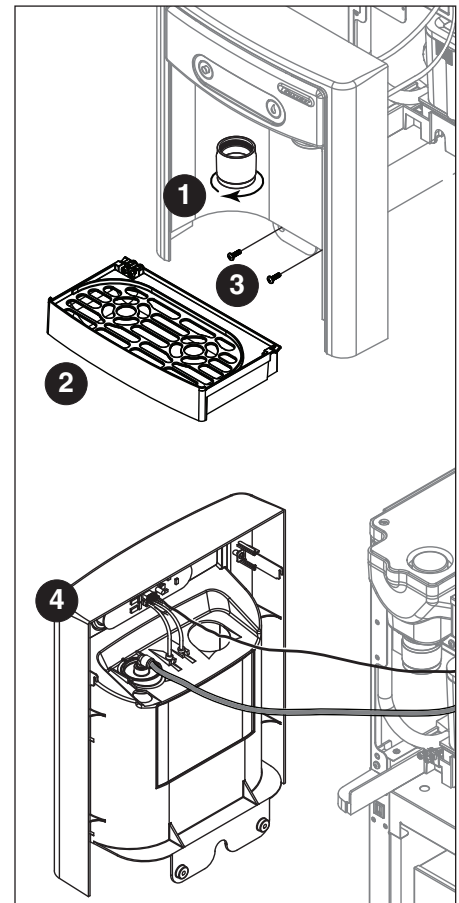
If you are using an “after market filter,” an adjustment may be made to activate the “Fresh Filtered Ice & Water” display.

Activating “Fresh Filtered Ice & Water”

1. Remove the front panel as explained in [Accessing Internal Components on page 9](#) then refer to **Fig. 7**.
2. Remove top panel (**Fig. 7.1**).
Note: For 15 Series dispensers, the right side panel must also be removed.
3. Remove (1) screw and top of control board enclosure (**Fig. 7.2**).
4. Locate the DIP switches on the dispenser's control board (**Fig. 8**). Use a fine-pointed object to move the “Filter” DIP switch (DIP switch #3) to the ON position.

Deactivating the Six-Month Maintenance/Filter Change Reminder

1. Use a fine-pointed object to move the “PM” DIP switch (DIP switch #8) to the ON position.

Fig. 7

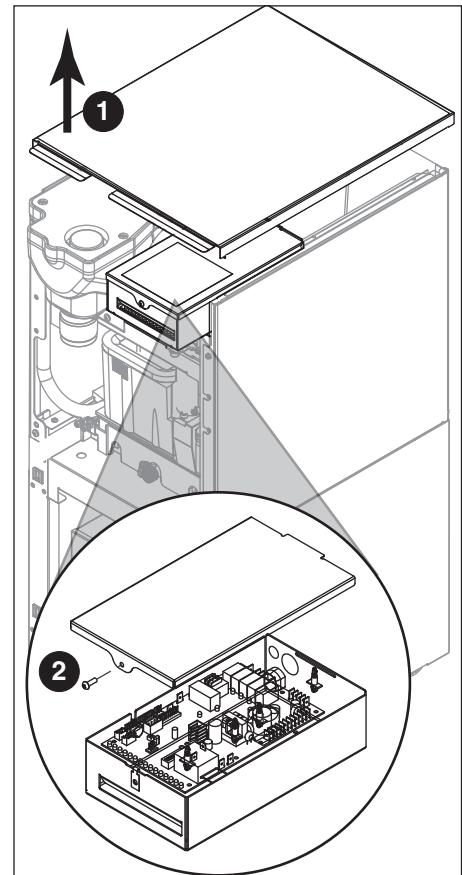
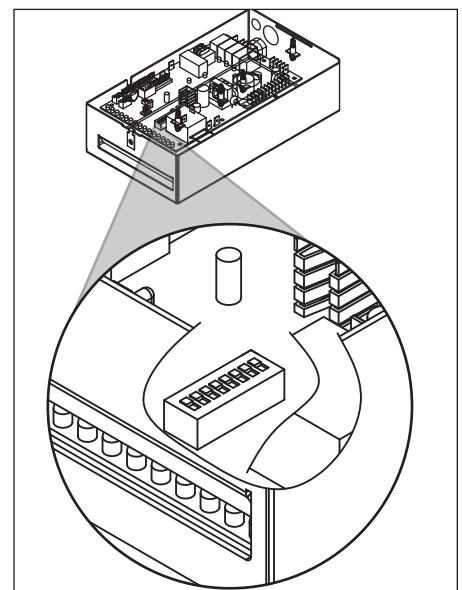

Fig. 8



	OFF	ON	
Not used (OFF position)		1	
Ice only		2	Ice and water
No internal filter		3	Internal filter supplied or to display "Fresh Filtered"
Not used (OFF position)		4	
Not used (OFF position)		5	
15 minute delay		6	30 minute delay
Not used (OFF position)		7	
Six-month PM enabled		8	Six-month PM disabled

Cleaning and Sanitizing Procedure

Cleaning and sanitizing should be performed at least every 6 months (more often if local water conditions dictate).

WARNING!

- Place the dispenser in Maintenance Mode prior to servicing or cleaning the ice machine. See [Maintenance/Cleaning Mode on page 9](#).
- For protection, rubber gloves and safety goggles (and/or face shield) should be worn when handling SafeCLEAN Plus™.
- Do not use bleach, it will damage the dispenser.

Required Supplies

- **15 Series:** Follow the directions on the SafeCLEAN Plus packaging to mix 6 gal (22.7 L) of Follett SafeCLEAN Plus solution. Use 100 F (38 C) water.
- Funnel, bucket, 38 C (100 F) potable water

Ice machine and Dispenser

1. Dispense all the ice out of the unit.
2. Press and hold maintenance/clean switch until  displays in the user interface to enter Maintenance Mode.
3. Remove (unscrew) chrome ice dispense chute (**Fig. 9.1**).
4. Remove drip tray (**Fig. 9.2**).
5. Remove (2) screws located behind the drip tray (**Fig. 9.3**).
6. Move front panel and place on top or beside unit (**Fig. 9.4**).
7. Remove plug cap from the end of water reservoir drain tube (**Fig. 9.5**) and lower tube to drain water into bucket. After the system has been drained of water replace plug cap in water reservoir drain tube.
8. Secure tube in holder.
9. Remove cap from storage bin lid cover (**Fig. 9.6**).
10. Screw storage bin lid cover cap onto ice discharge chute (**Fig. 9.7**).

Fig. 9



11. Locate the storage bin drain tube pinch clamp (**Fig. 10**) and engage (close).
12. Pour SafeCLEAN Plus solution into bin lid access spout until solution reaches *and remains level* at the spout neck. (Because the cleaning solution reaches the internal components via overflow into the ice transport tube, it is necessary to add cleaning solution until it remains level at the spout neck.)
13. Allow the SafeCLEAN Plus solution to remain in unit for 15 minutes.
14. While machine is cleaning, remove top and right side panel to access and clean air-cooled condenser.
15. Submerge ice dispense chute in the remainder of SafeCLEAN Plus solution for 2 minutes. Rinse with clean, potable water.
16. Drain system: (1) release (open) the storage bin drain tube pinch clamp and (2) lower water reservoir drain tube into bucket.
17. Secure capped water reservoir drain tube into holder and engage (close) storage bin drain tube pinch clamp.
18. Fill and drain three times with potable water. Secure water reservoir drain tube and release (open) the storage bin drain tube pinch clamp.
19. Place a bucket under the dispense chute and remove cap.
Note: Some solution will remain and drain out when cap is removed. Reposition cap on bin lid spout.
20. Reinstall front panel, ice dispense chute, and drip tray.
21. Press and hold maintenance/clean switch to exit Maintenance Mode.

Fig. 10

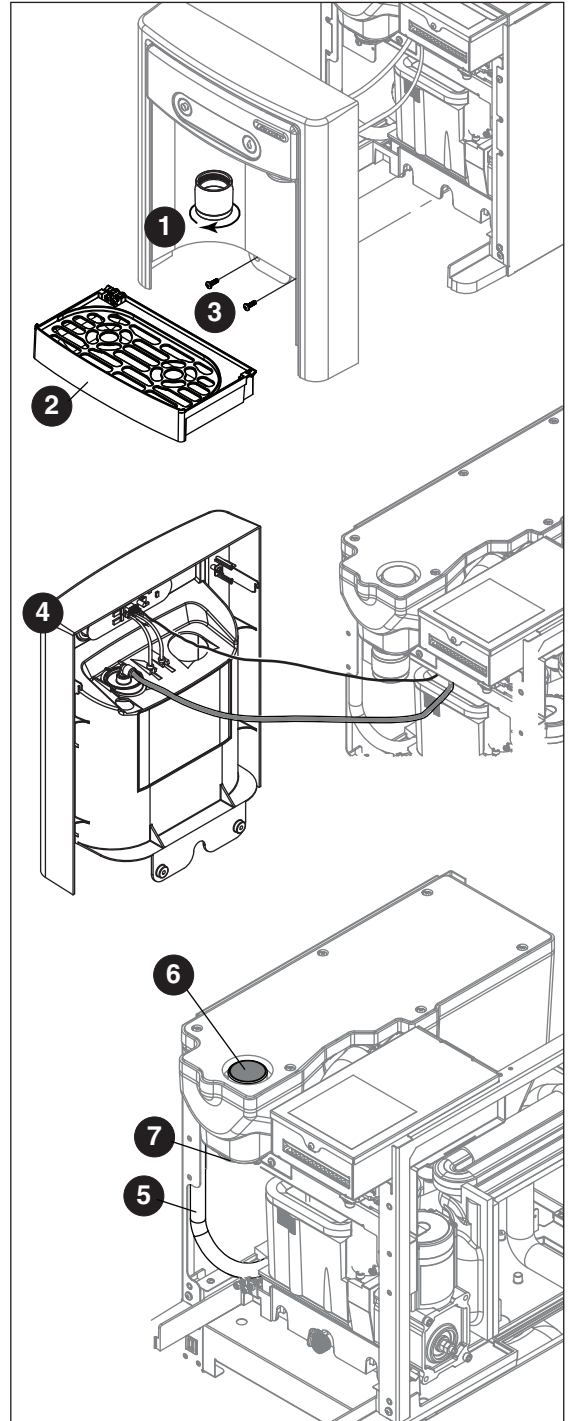
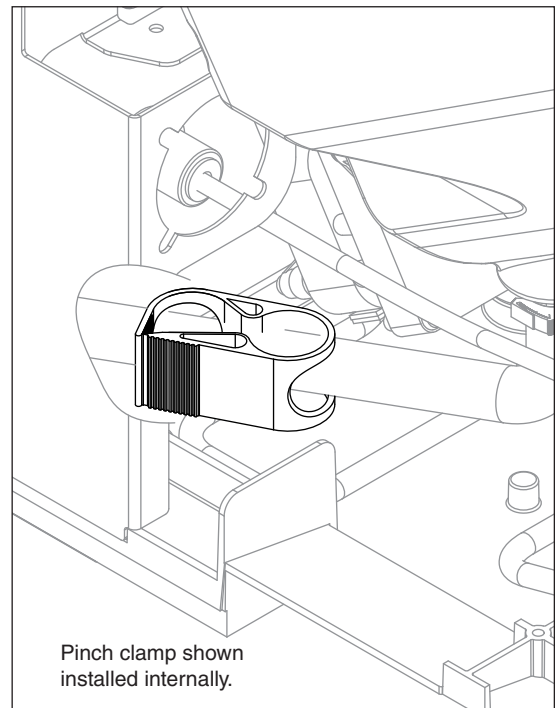

User Interface and Exterior Cabinet

1. Press and release maintenance/clean switch so that only "FRESH FILTERED ICE AND WATER" displays in the user interface to enter Cleaning Mode (and disable dispensing).
2. Plastic parts, including the user interface, can be cleaned with a non-abrasive glass cleaner. Clean stainless steel panels with stainless steel cleaner.
3. Press and release maintenance/clean switch to put unit back into service.

Service

LED Indicator Description

The LED Indicator is located behind the front panel.

Fig. 11



LED Name	LED Color	Description
Clean	Green	The dispenser is in Cleaning Mode. Dispenser is disabled to allow for cleaning of front panel. See Maintenance/Cleaning Mode on page 9 .
—	N/A	Not used.
PM	Red	Six-month periodic maintenance required.
Drip tray	Red	Drip tray full.
Water leak	Red	Internal leak in dispenser.
High amps	Red	Auger gearmotor has exceeded 0.55A. The HI amps and Time delay LEDs will illuminate, the machine will shut down for one hour, the LEDs will turn off, and the machine will resume normal operation.
Service	Red	8000 hour bushing check (call Follett technical service group at (877) 612-5086 or +1 (610) 252-7301).
Maintenance	Yellow	Enter Maintenance Mode by pressing and holding maintenance/clean switch for 5 seconds. Unit will not make or dispense ice.
Low water	Yellow	Insufficient water supply to machine or no low bin LED upon startup.
Time delay	Yellow	Ice production will not resume for at least 15 minutes after a full bin is achieved and a minimum amount of dispense activity has elapsed.
Sleep cycle	Green	After a full bin and 10 minutes of non-use, the unit goes into standby and will not produce ice until either: 7 Series: 12 hours has elapsed, 15 Series: 4 hours has elapsed or ice or water has dispensed.
Making ice	Green	Gearmotor, compressor, and fan motor energized.
Low bin	Green	Bin switch closed calling for ice.
Power on	Green	Power supplied to unit.

Evaporator Disassembly

1. Disconnect power from the dispenser.
2. Turn off water supply to dispenser.
3. Remove (unscrew) chrome ice dispenser chute (Fig. 12.1).
4. Remove the drip tray (Fig. 12.2).
5. Remove the two screws (Fig. 12.3) on the front panel (behind the drip tray).
6. Remove and set aside the front panel (Fig. 12.4). Do not disengage the plug on the back of the User Interface.
7. Lift and remove the top panel, set aside (Fig. 12.5).
8. Remove two screws (Fig. 12.6) and remove left side panel.
9. Remove two screws (Fig. 12.7) and remove right side panel.

Fig. 12

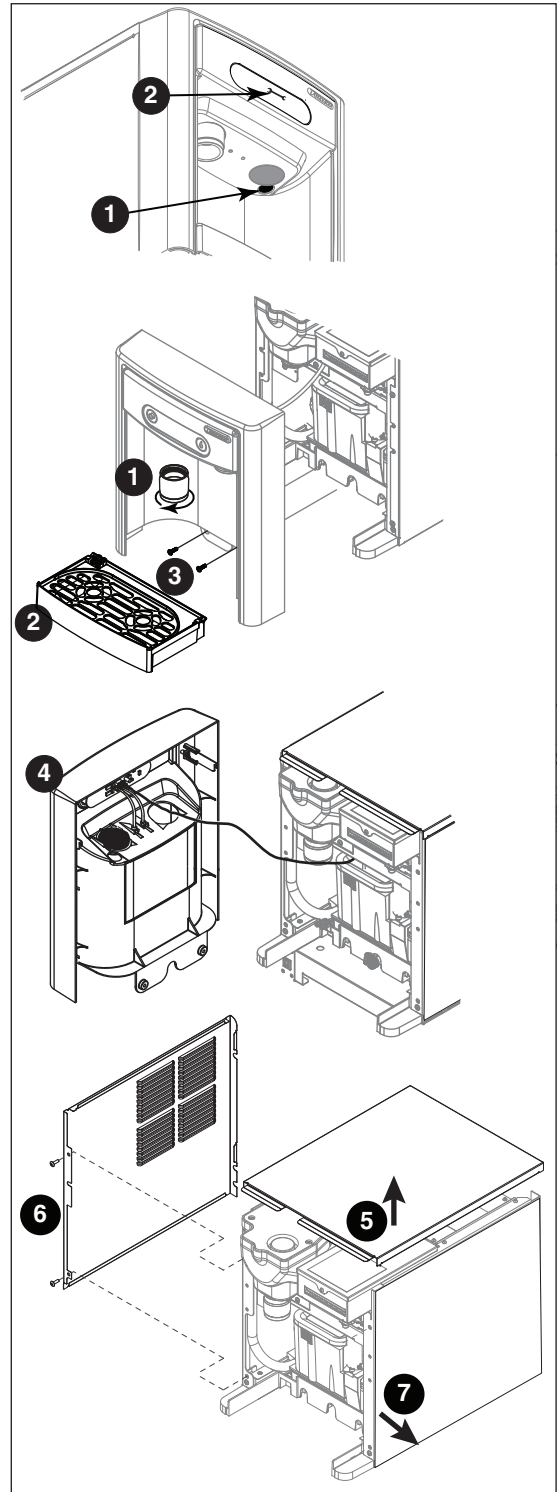

10. Unplug the gear motor (three connectors) (Fig. 13).

11. Remove ground screw connection.

Fig. 13

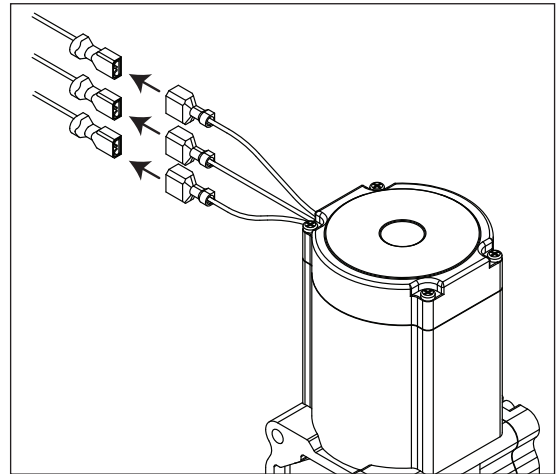

12. Remove gear motor:

- Remove M6 allen screw, retainer, spacer and key (Fig. 14.1).
- Remove two M6x90 allen screws (Fig. 14.2).
- Pull gear motor from auger (Fig. 14.3).
- Remove main housing insulation (Fig. 14.4).

13. Remove all traces of Petrol-gel from auger shaft.

Fig. 14

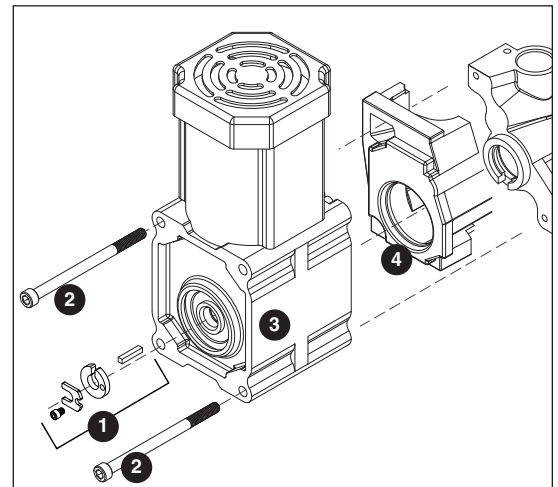

14. Remove compression nozzle:

- Loosen hose clamp (Fig. 15.1).
- Remove transport tube (Fig. 15.2).

Fig. 15

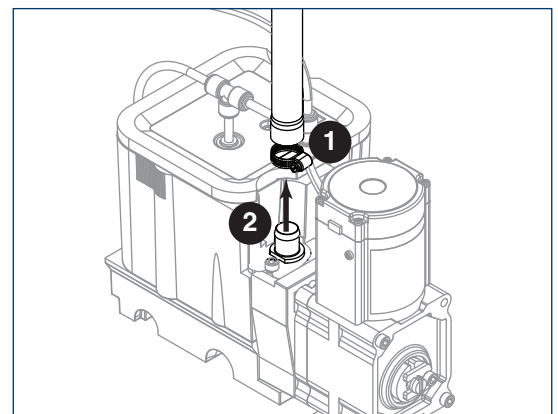

15. Remove M6 socket head allen screw (Fig. 16.1).
16. Remove compression nozzle retainer (Fig. 16.2).
17. Remove compression nozzle (Fig. 16.3).

Fig. 16

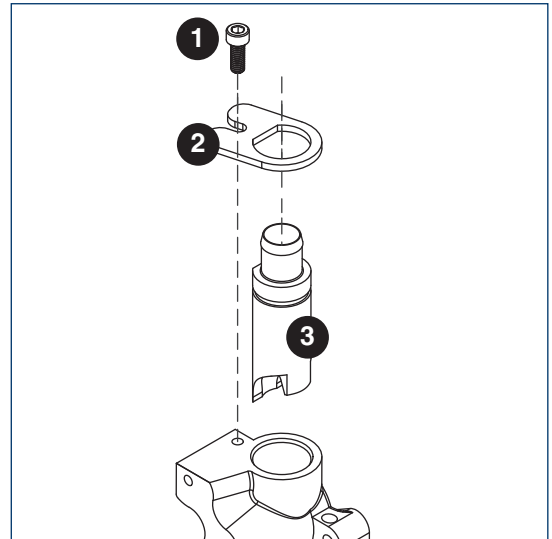

18. Remove main housing:
 - Disconnect vent line from T fitting (Fig. 17.1).

Fig. 17

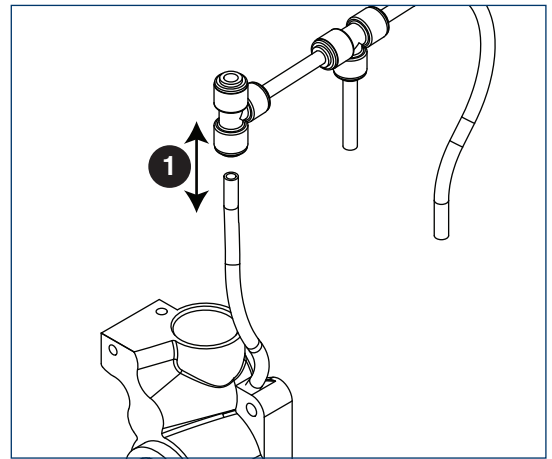

19. Remove three M6x25 socket head allen screws (Fig. 18.1).
20. Remove main housing (Fig. 18.2).

Fig. 18

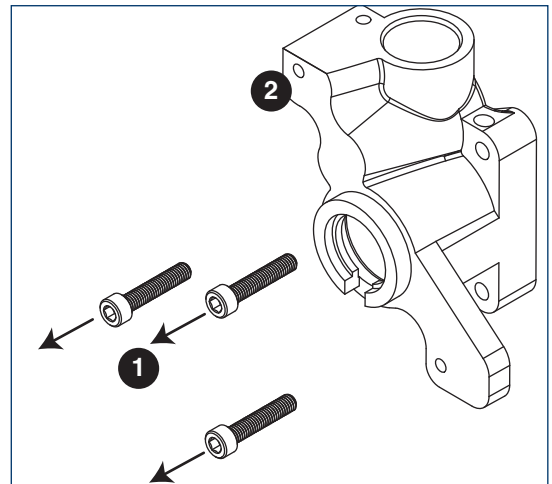

21. Remove and discard mating ring and seal (**Fig. 19.1**).
22. Carefully remove auger (**Fig. 19.2**).



WARNING!

Use caution when removing auger. The auger is very sharp - handle with care to avoid personal injury.

Evaporator Assembly

1. Remove and inspect main housing O-ring seal. Replace if damaged in any way.
2. Clean O-ring groove. Lubricate O-ring with Petrol-gel and reinstall.
3. Use cardboard disc to press new mating ring into main housing (**Fig. 20.1**).
4. Lube the shaft with liquid soap in the area shown (**Fig. 20.2**) and slip on seal and spring (**Fig. 20.3**).

Note: Do not touch the sealing surfaces with bare hands. Contact with bare skin will cause premature seal failure.

5. Install auger (**Fig. 20.4**).

6. Install main housing:

- Slide main housing onto auger shaft (**Fig. 21.1**).
- Install three M6x25 allen screws (**Fig. 21.2**).
- Connect vent line to T fitting (**Fig. 21.3**).

Fig. 19

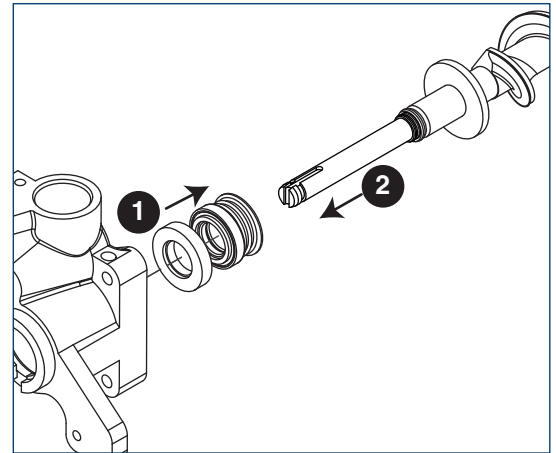

Fig. 20

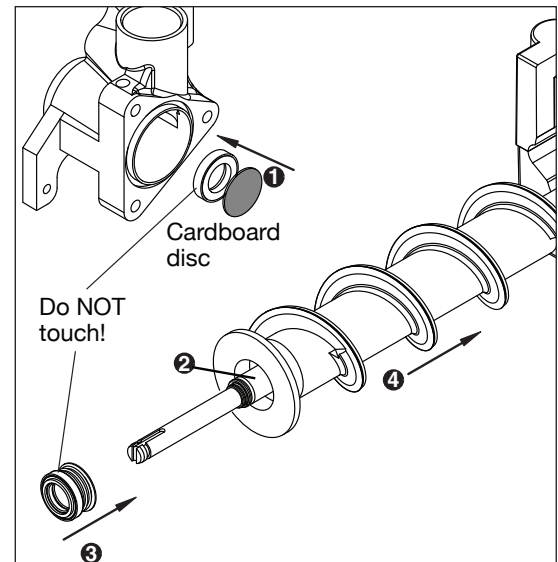
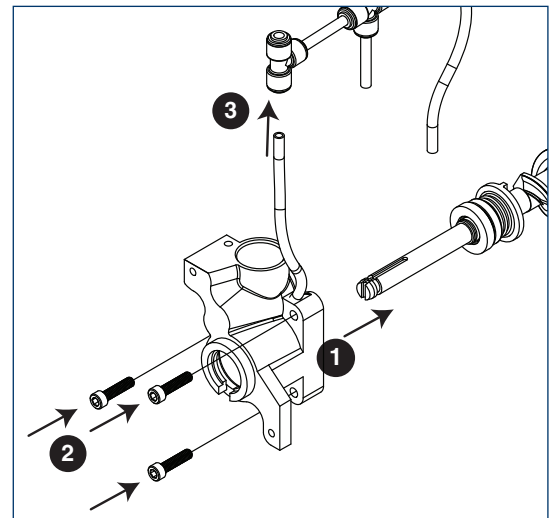

Fig. 21



7. Install compression nozzle:

- Remove and inspect compression nozzle O-ring seal. Replace if damaged in any way.
- Clean O-ring groove. Lubricate O-ring with Petrol-gel and reinstall.
- Install compression nozzle (**Fig. 22.1**).
- Install compression nozzle retainer (**Fig. 22.2**).
- Install M6 socket head allen screw (**Fig. 22.3**).

Fig. 22

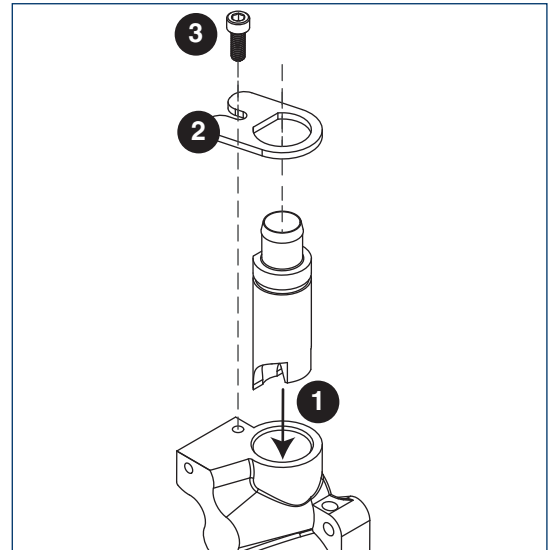

8. Install transport tube (**Fig. 23.1**).

9. Tighten hose clamp (**Fig. 23.2**).

Fig. 23

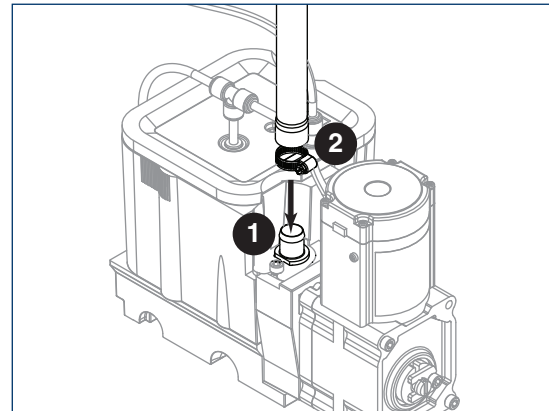

10. Install gear motor:

- Install main housing insulation (**Fig. 24.1**).
- Slide gear motor onto auger shaft (**Fig. 24.2**).
- Install two M6x90 allen screws (**Fig. 24.3**).

Fig. 24

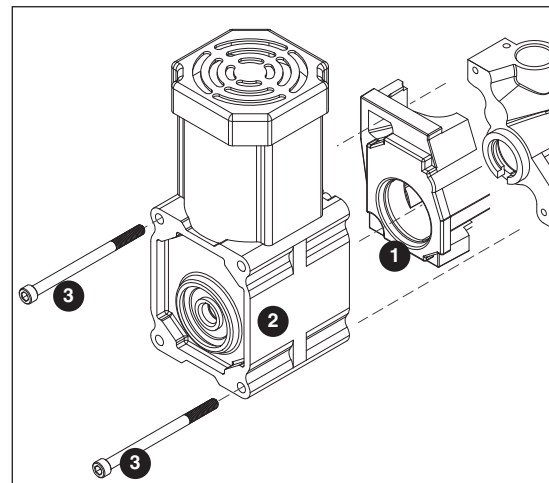

11. Use screwdriver to orient auger shaft to align with motor shaft keyway (**Fig. 25.1**).
12. Install key into keyway (**Fig. 25.2**).

Fig. 25

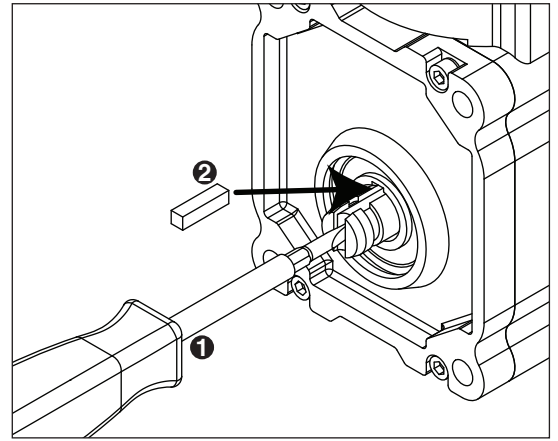

13. Install spacer, ensure that key is captured in slot (**Fig. 26.1**)

Fig. 26

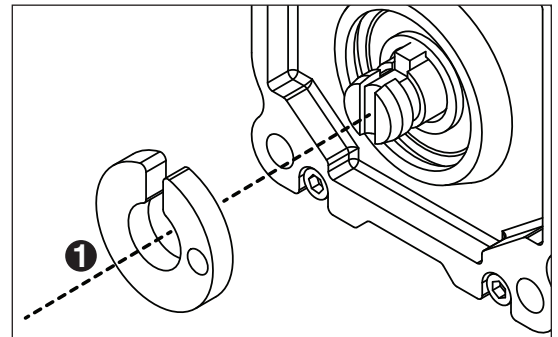

14. Insert screwdriver into groove of auger shaft and pry shaft outwards (**Fig. 27.1**).
15. Insert retainer into groove (**Fig. 27.2**), ensure that retainer is aligned with hole in spacer.

Fig. 27

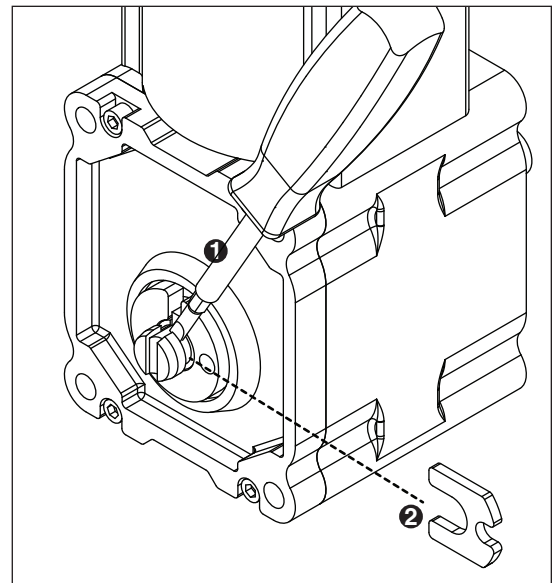

16. Install screw and tighten (**Fig. 28.1**).

Fig. 28

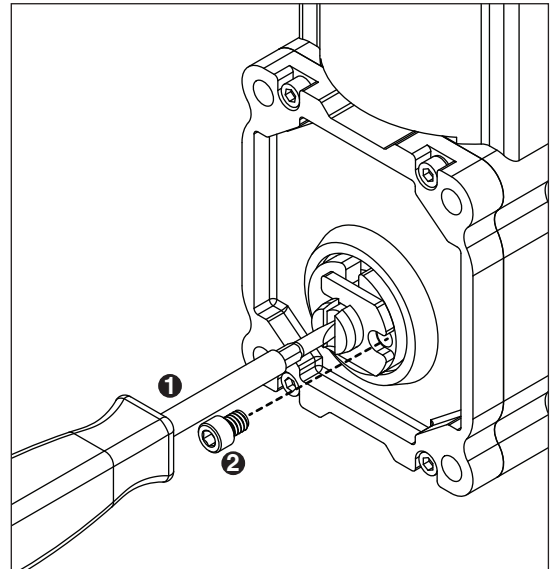

17. Plug in gear motor (**Fig. 29**).

- BLUE to BLUE
- BLACK to BLACK
- WHITE to WHITE
- Connect ground wire with ground screw.

Fig. 29

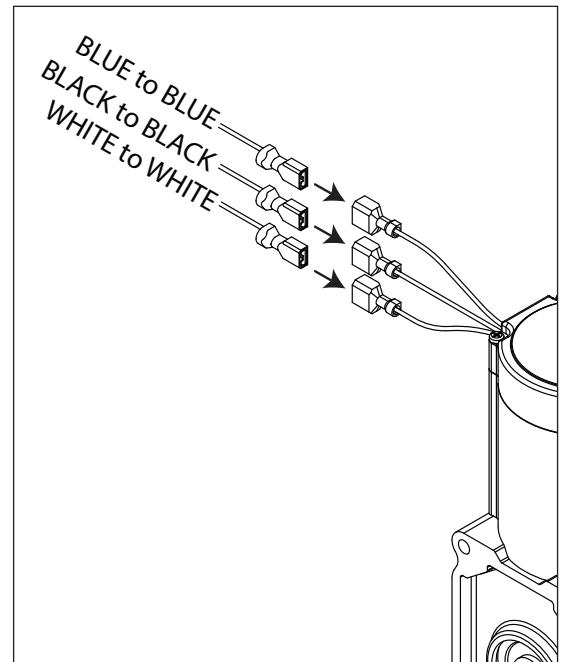

Water Feed Schematic

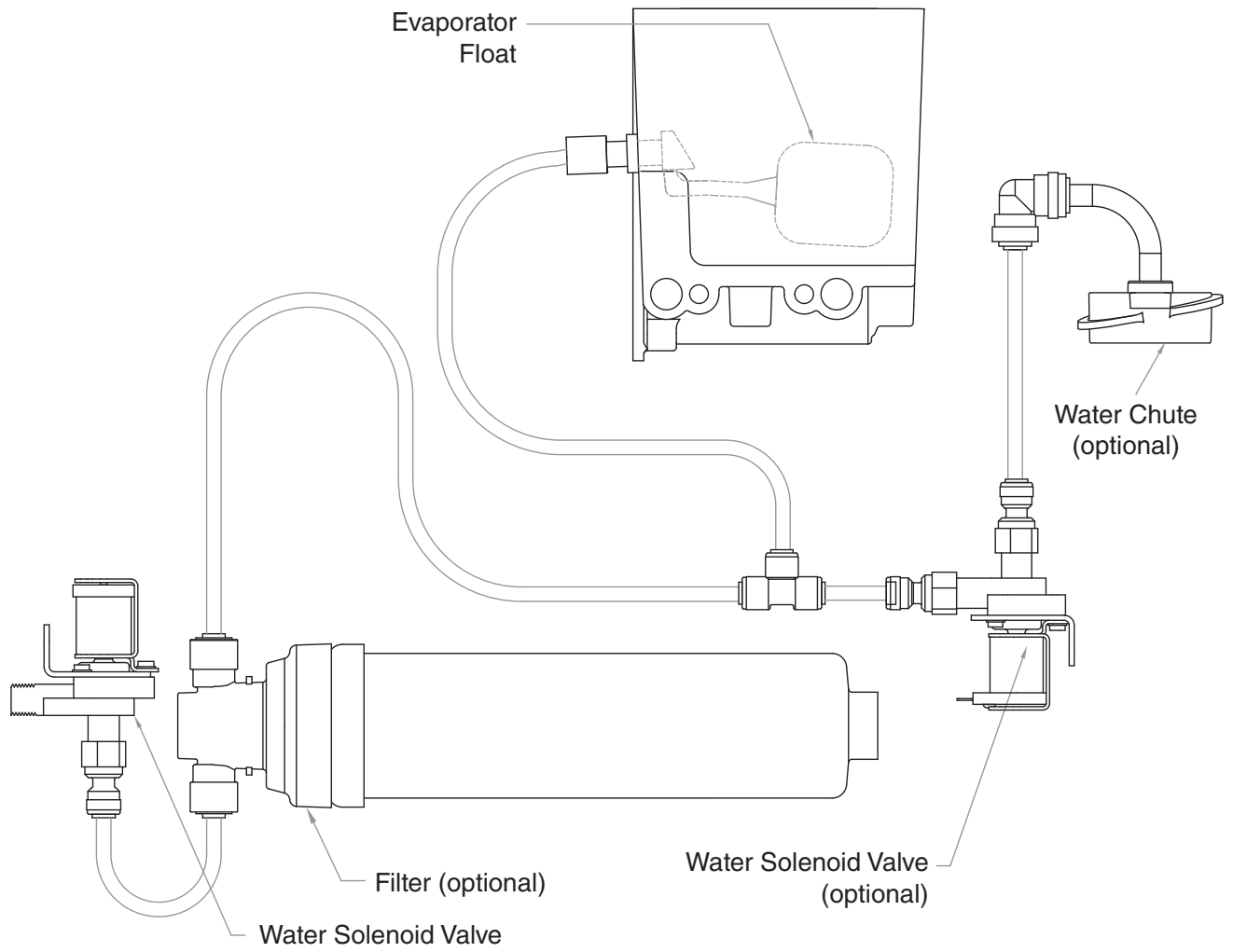

Storage Bin Melt Water/Evaporator Feed/Clean Out System Schematic

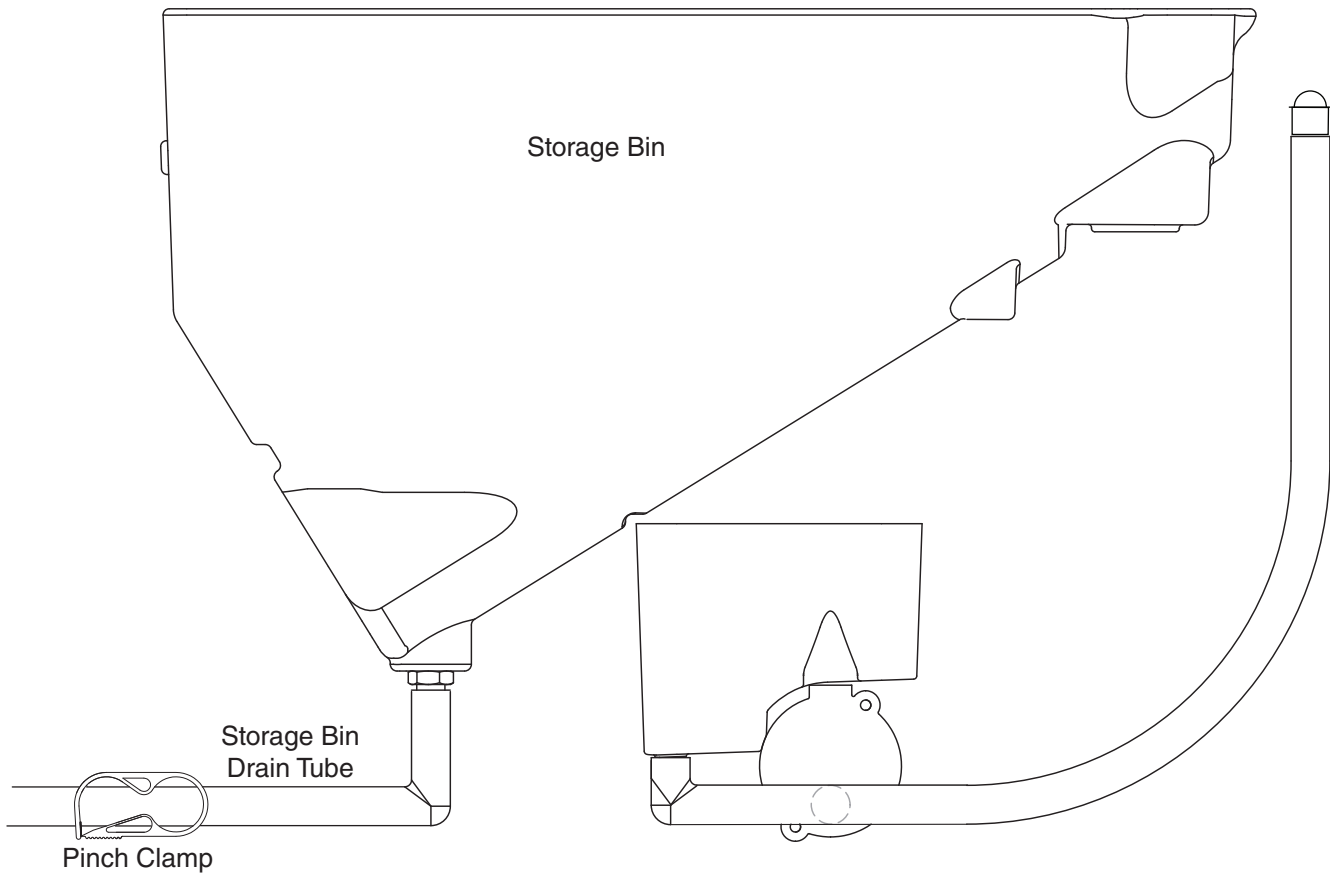

Vent System Schematic

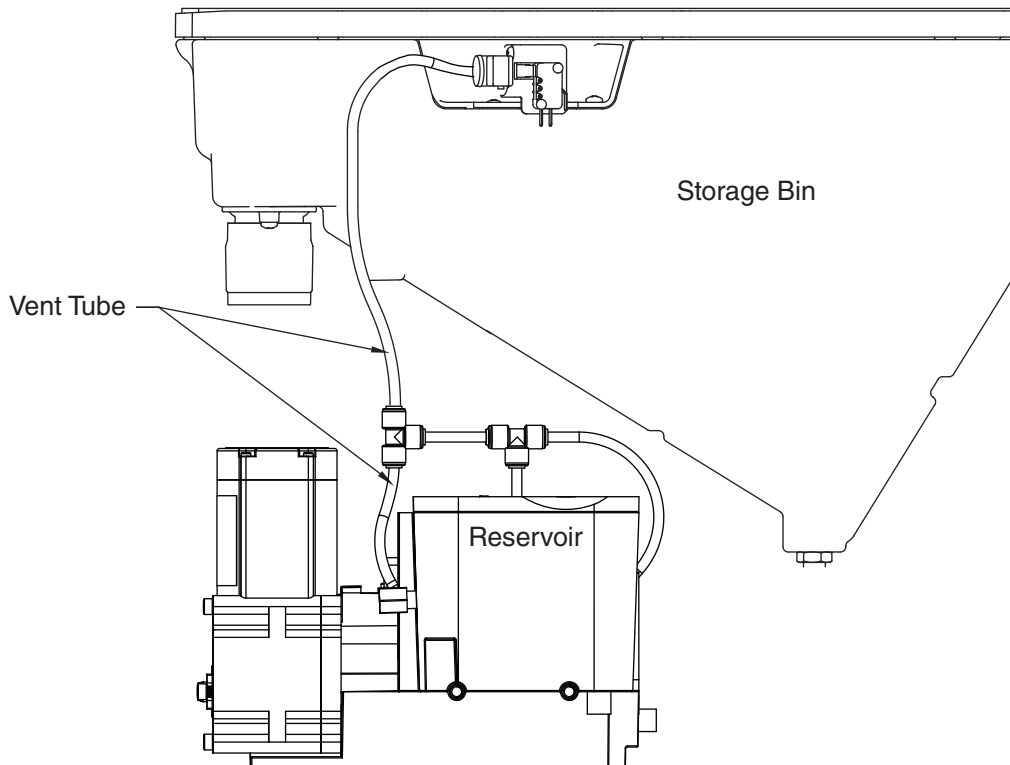

Refrigeration Schematic

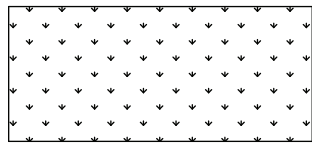
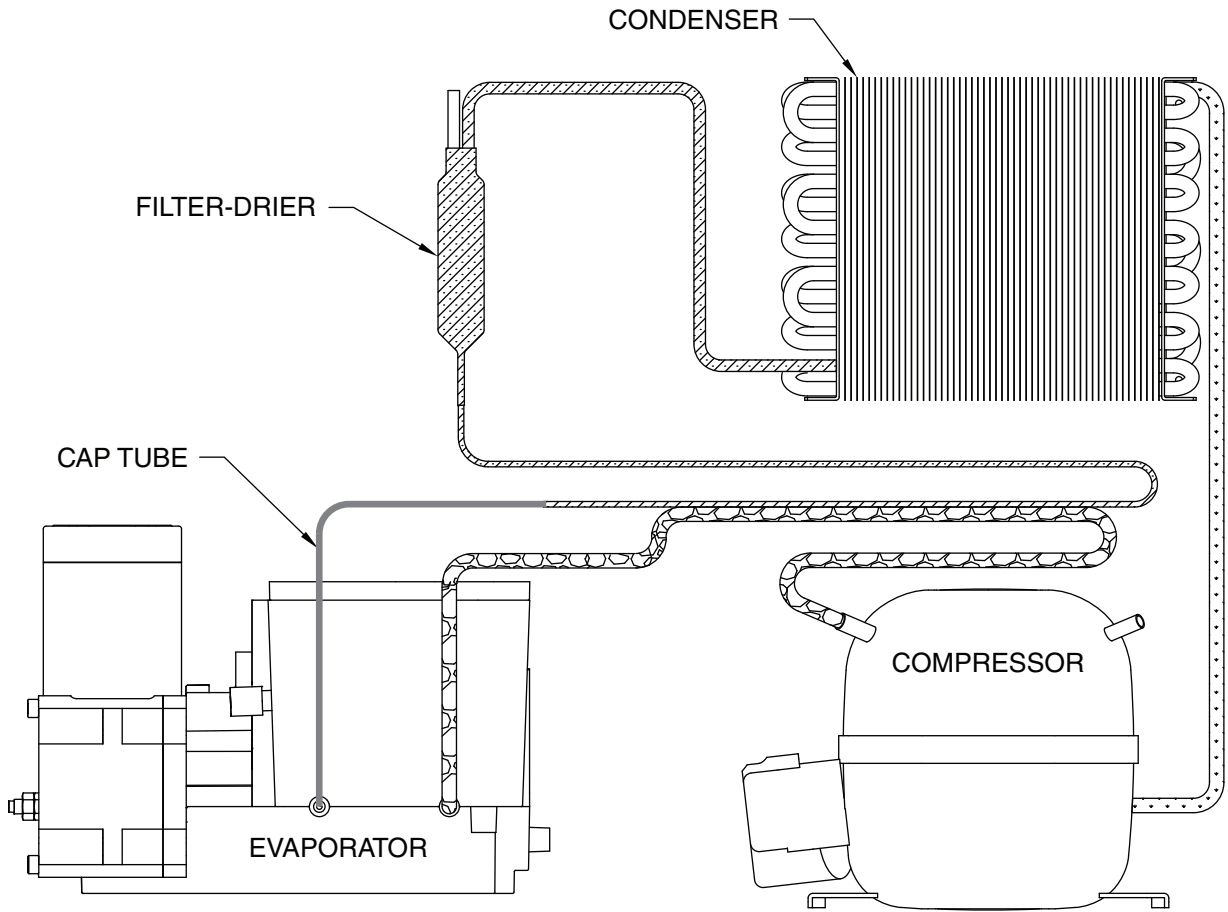

HIGH PRESSURE VAPOR



LOW PRESSURE LIQUID

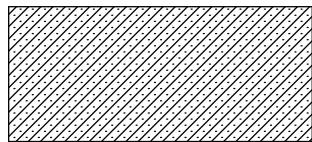

HIGH PRESSURE LIQUID

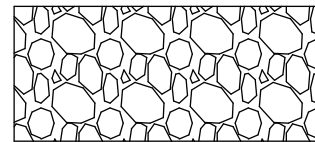





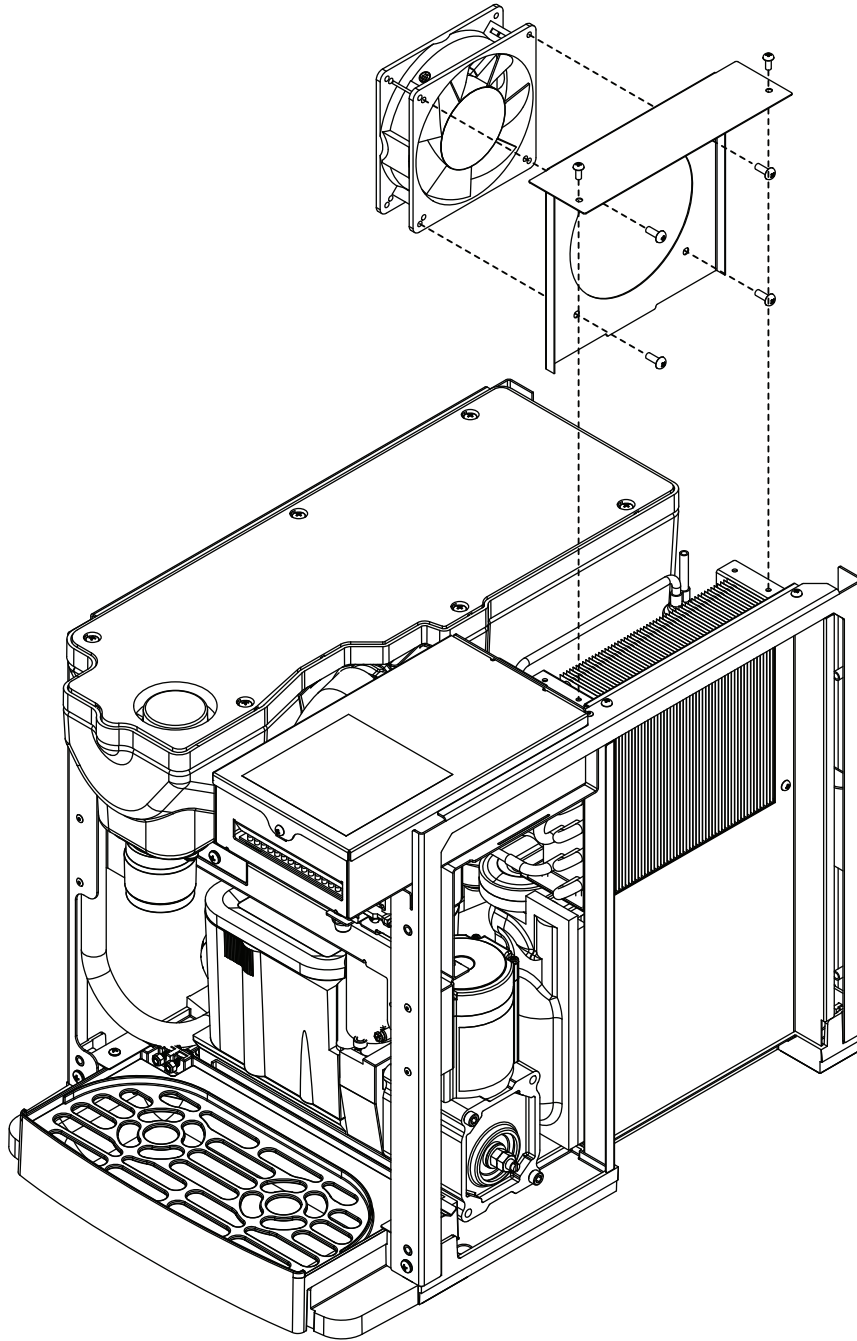

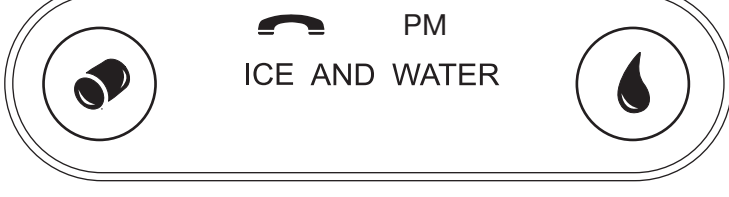
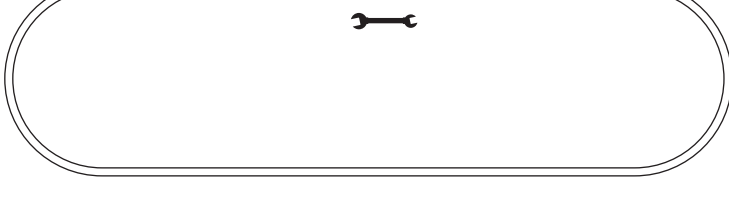

LOW PRESSURE VAPOR

Condenser Fan Motor Removal (7 Series Shown)



User Interface Display Identification

Operation Display	Condition	Procedure
	Normal operation	—
	Cleaning Mode	Press and release maintenance/clean switch to clean the user interface without dispensing ice or water.
	Drip tray full	Empty drip tray.
	Six-month periodic maintenance required	Follow Maintenance Mode procedure (below) and also see Cleaning and Sanitizing Procedure .
	Maintenance Mode	Enter Maintenance Mode by pressing maintenance/clean switch until  displays. Complete the cleaning and sanitizing procedure and change the filter, if so equipped. Exit Maintenance Mode by pressing and holding maintenance/clean switch until  no longer displays.
	Service - 8000 hr bushing check	Call Follett Technical Service Group at (877) 612-5086 or +1 (610) 252-7301. The flashing wrench indicates that the 8000 hr bushing check is required.

Service Display	Condition	Procedure
 <p>FRESH FILTERED ICE AND WATER</p>	High amps	Contact Follett technical service group at (877) 612-5086 or +1 (610) 252-7301. Note: For dispensers after serial number D45191, the phone and wrench will <i>not</i> be illuminated.
 <p>FRESH FILTERED ICE AND WATER</p> <p>CHECK FOR LEAKS</p>	Internal leak in dispenser	Locate leak and repair - Press reset on control board. Contact Follett if unit is leaking.
	Sleep mode	Press either dispense button to return to normal operation.

Electrical Wiring Diagram

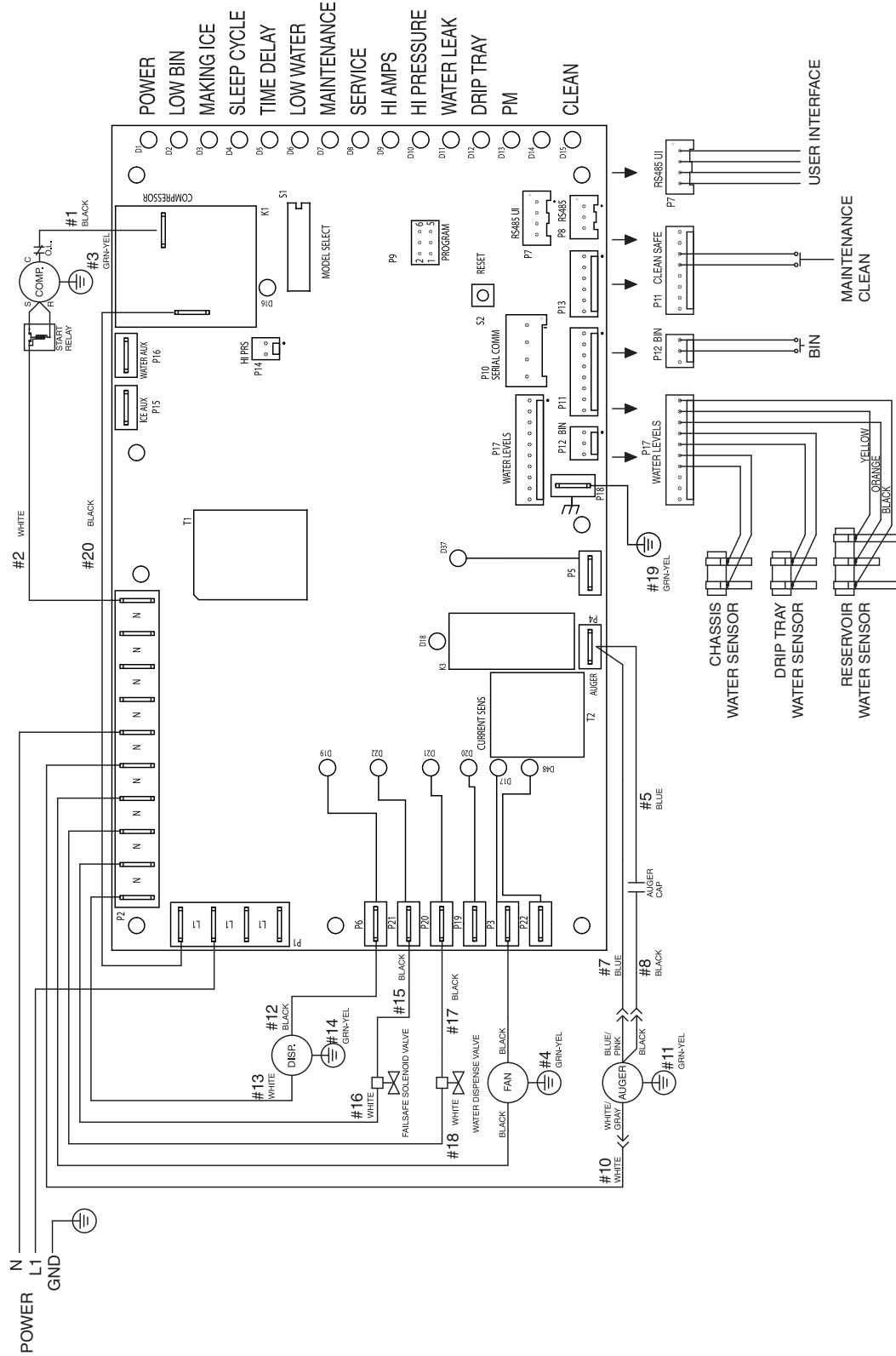

Parts

15 Series Exterior

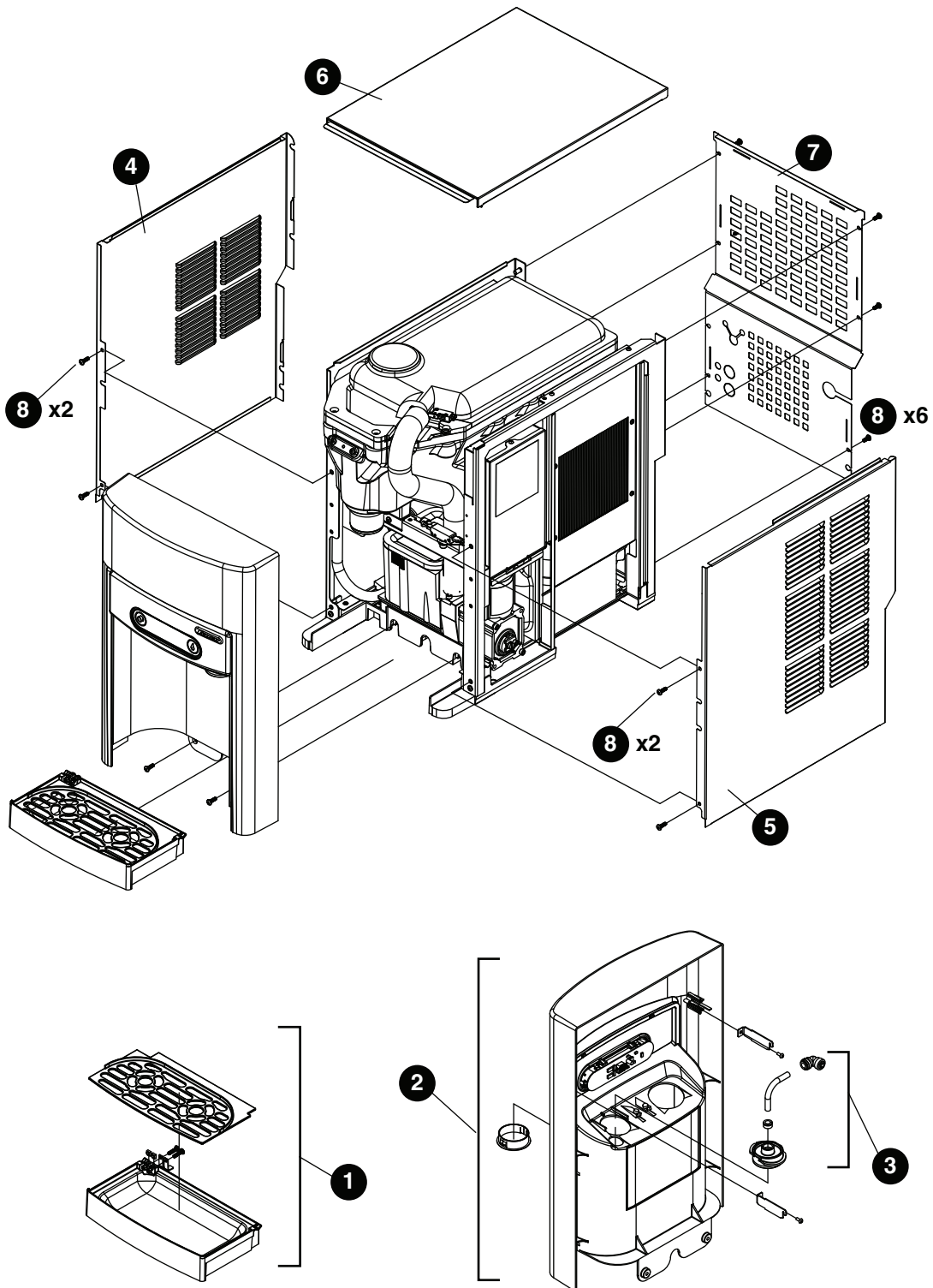

Exterior

Reference #	Description	Part #
1	Drip Tray Assy	00957613
2	Panel, Front Assy - Includes Water Nozzle and Plug	01036425
3	Chute, Water (water option)	00957688
4	Panel, Left	01026343
5	Panel, Right	01026335
6	Panel, Top	01054733
7	Panel, Rear	01025980
8	Screw, M5 x 12 Phillips	00931931
Not Shown	Cord, 115 VAC	00958058
Not Shown	15 Series Packaging for Returns, Dispenser	01054634
Not Shown	Fitting, Elbow - 1/4" FPT x 1/4" Tube	00974261
Not Shown	Fitting, Elbow - 1/4" FPT x 3/8" Tube	00990796
Not Shown	Drip Tray Drain Kit	00956375
Not Shown	Drip Tray Drain Kit with 4" legs	00981977
Not Shown	Covers, Agion, User Interface	00969030

15 Series Interior

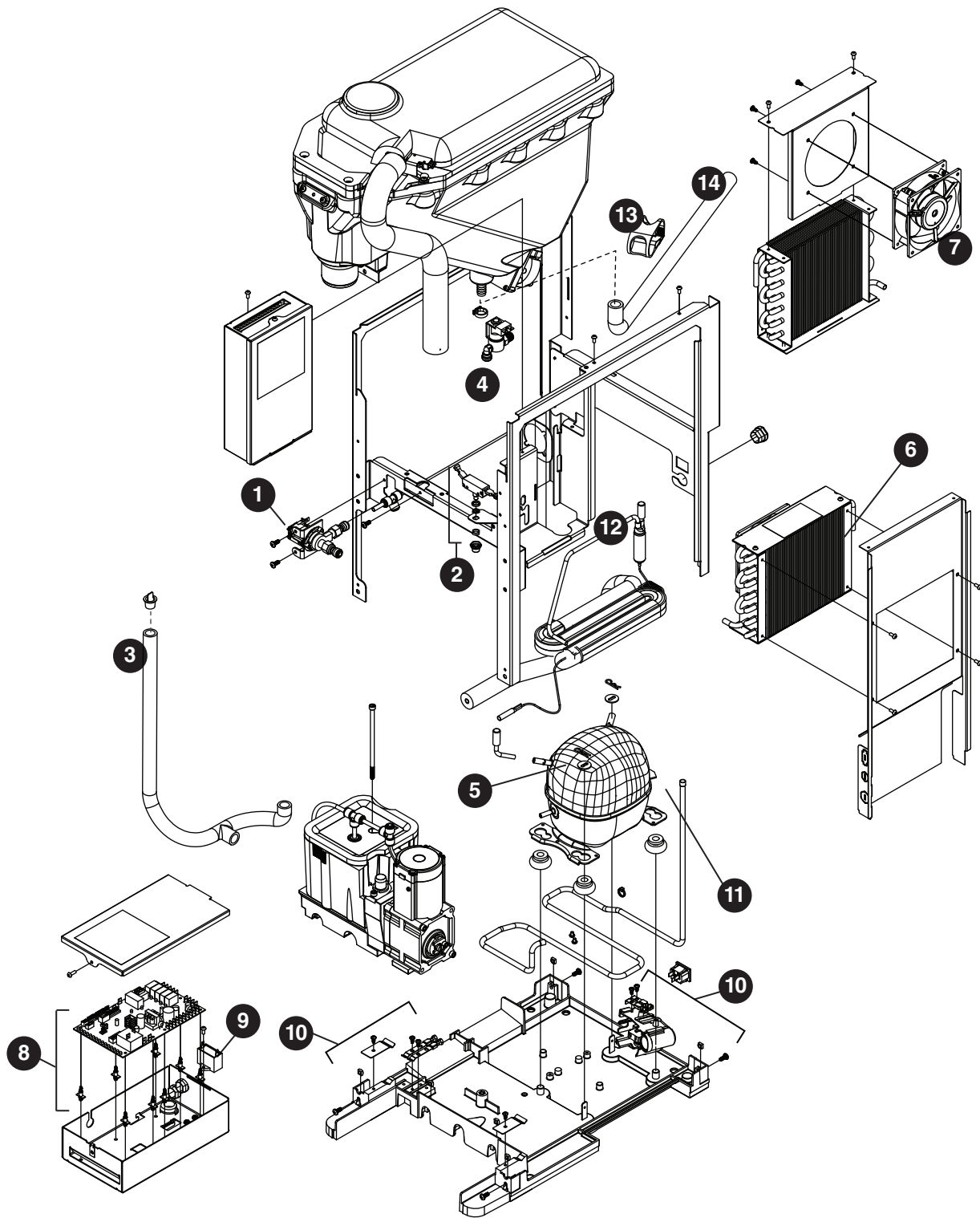

Interior

Reference #	Description	Part #
1	Valve, Dispense Solenoid (water option)	00957704
2	Switch, Cleaning	00957712
3	Drain/Feed Tube with Cap	01102946
4	Valve, Failsafe Solenoid	00957738
5	Compressor with Mounting Hardware	01157296
6	Condenser	00958017
7	Condenser Fan, Cord and Hardware	01157288
8	Control Board with Stand-offs	01051978
9	Capacitor, Gearmotor	00958041
10	Sensor, Retainer Hardware Kit	00958066
11	Relay and Overload	00157387
12	Heat Exchanger, Kit	01233998
13	Pinch clamp, Storage Bin Tubing	00988238
14	Tubing, Storage Bin Drain (includes barb fitting and hose clamp)	01102979

15 Series Bin Assembly

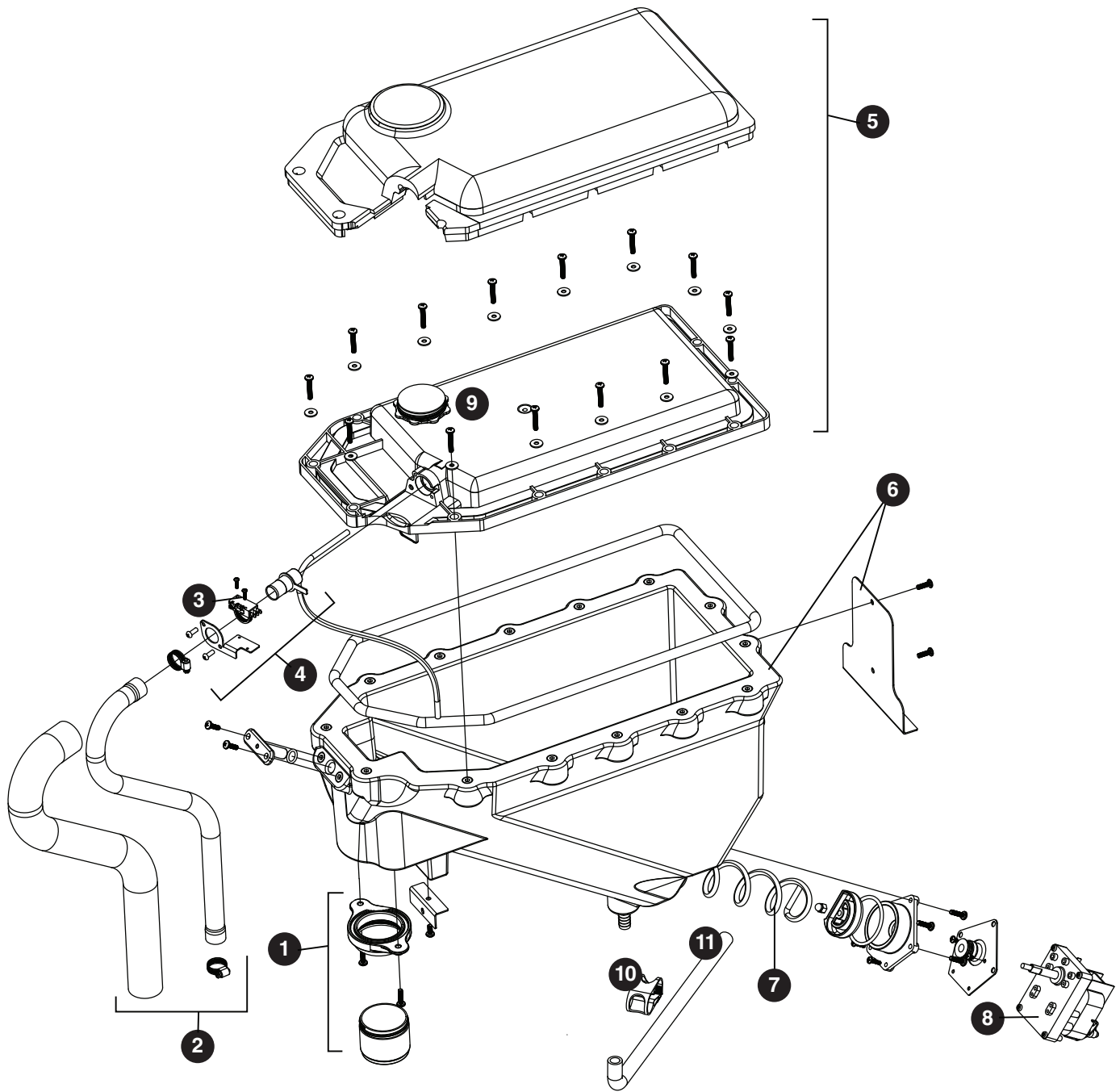

15 Series Bin Assembly

Reference #	Description	Part #
1	Ice Chute Assembly	01051846
2	Ice Transport Tubing with Insulation	01051960
3	Switch, Shuttle	00957753
4	Shuttle, Complete Assy	01053248
5	Lid, Bin Assy	01053255
6	Bin, Assy	01053263
7	Auger, Dispense	01026251
8	Motor, Dispense	00957803
9	Cap and Insulation, Bin	01053305
10	Pinch clamp, Storage Bin Tubing	00988238
11	Tubing, Storage Bin Drain (includes barb fitting and hose clamp)	01102979

Evaporator Assembly

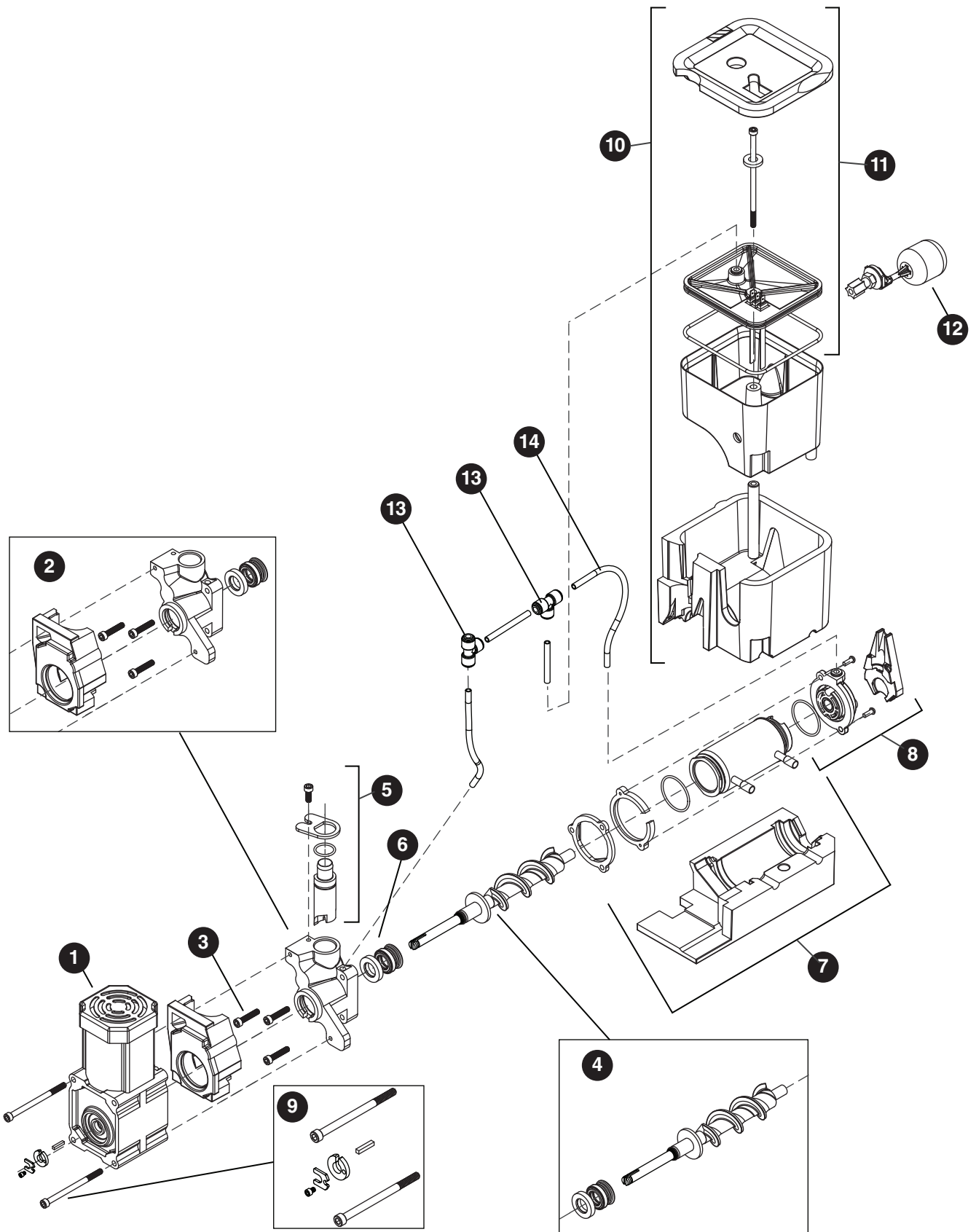

Evaporator Assembly

Reference #	Description	Part #
1	Gearmotor Assy	00957811
2	Main Housing with Front Seal and Screws	00957829
3	Screws, Main Housing	00957837
4	Auger with front seal	00957845
5	Ice Compression Nozzle Assy	00957852
6	Front Seal and O-Ring	00957860
7	Evaporator Assembly with Insulation	01157353
8	Housing, Bushing with Insulation	00957886
9	Hardware kit, Gearmotor (For serial numbers E01087 and above)	01048628
9	Hardware kit, Gearmotor (For serial numbers below E01087)	00957894
10	Reservoir and Float Complete Assy	00957902
11	Lid, Reservoir with Insulation and O-Ring	00957910
12	Float Valve	00957928
13	"T" Fitting - 1/4"	502923
14	Tubing - 1/4" (sold in 12" increments)	502079

Miscellaneous

Reference #	Description	Part #
Not Shown	Water filter cartridge, 5 micron	00968107
Not Shown	IMS III sanitizer concentrate, 16 oz	00979674
Not Shown	SafeCLEAN Plus liquid, 6 pack	01149954
Not Shown	SafeCLEAN Plus liquid, case of 24	01149962
Not Shown	6" Legs for base stand, set of 4	00956318
Not Shown	4" Legs for countertop dispenser, set of 4	00956300

Warranty Registration and Equipment Evaluation

Thank you for purchasing Follett® equipment. Our goal is to deliver high value products and services that earn your complete satisfaction by delivering high-value products and services backed by outstanding customer and technical support.

Please review the installation instructions thoroughly. It is important that the installation be performed to factory specifications so your equipment operates at its maximum efficiency.

Follett LLC will not be liable for any consequential damages, expenses, connecting or disconnecting charges, or any losses resulting from a defect of the machine. For full warranty details, visit our website www.follettice.com/productwarranties.

Registering your equipments helps Follett track your equipment's service history should you need to contact us for technical support, and your feedback helps us improve our products and services. Please visit www.follettice.com/support to complete the Warranty Registration form.

Should you have any questions, please contact Follett's technical support group at (877) 612-5086 or (610) 252-7301 and we will be happy to assist you.

SafeCLEAN Plus is a trademark of Follett LLC.

Chewblet and Follett are registered trademarks of Follett LLC, registered in US.



801 Church Lane • Easton, PA 18040, USA
Toll free (877) 612-5086 • +1 (610) 252-7301
www.follettice.com



01214261R01
© Follet LLC 12/18