

MCD425A/W, R425A/W, MFD425A/W, P425A/W Ice Machines

Operation and Service Manual
Serial numbers below K39864

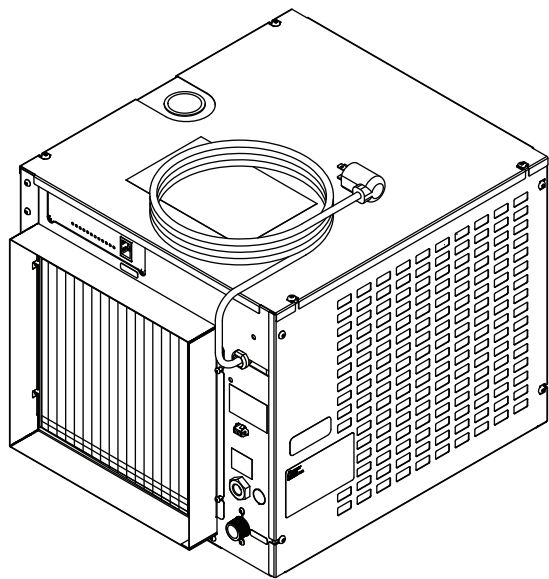

MCD425A/W_S
R425A/W

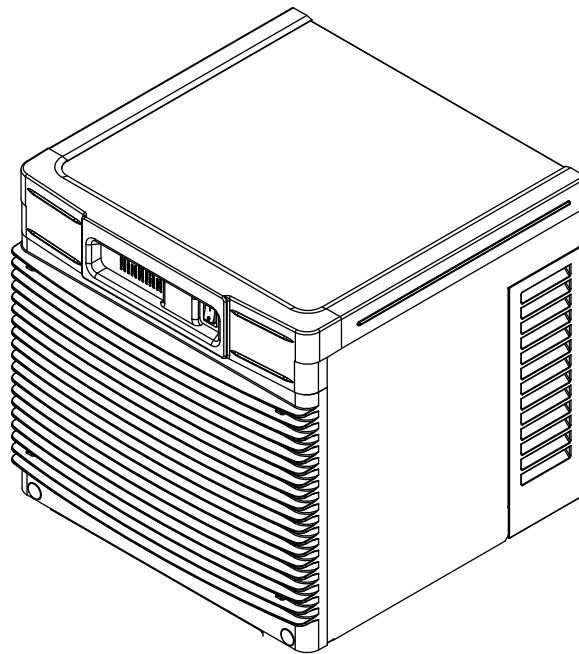

MCD425A/W_T
MFD425A/W_T

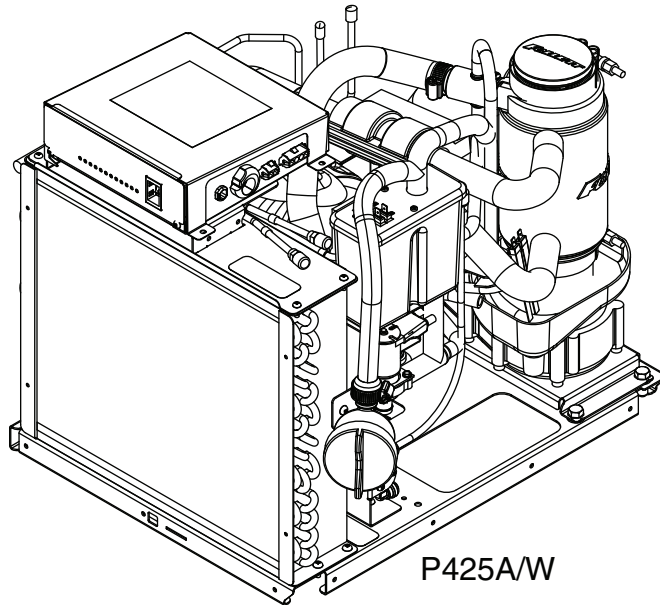

P425A/W

**Following installation, please forward this manual
to the appropriate operations person.**

Contents

Welcome to Follett	4
Before you begin	4
Specifications	5
Electrical	5
Plumbing	5
Ambient	5
Water usage (water-cooled condenser only)	5
Dimensions and clearances	6
Operation	7
Cleaning/descaling and sanitizing	7
Weekly	7
Monthly	7
Semi-Annually (more often if conditions dictate)	7
Service	9
Ice machine Operation (all models)	9
Water system	10
Electrical system	11
Technical specifications (all models)	13
Electrical control system schematic	14
Electrical control system operation	15
Refrigeration system (all models)	24
Replacement parts	27
Replacement ice machine ordering matrix	27
Air-cooled skins assembly (MCD425A_S, R425A)	28
Water-cooled skins assembly (MCD425W_S, R425W)	29
Louvered docking station (MCD425A/W_T)	30
Electrical components	31
Evaporator	32
Air-cooled ice machines	34
Water-cooled ice machines	36

Welcome to Follett

Follett equipment enjoys a well-deserved reputation for excellent performance, long-term reliability and outstanding after-the-sale support. To ensure that this equipment delivers that same degree of service, we ask that you review the installation portion of this manual before beginning to install the unit. Our instructions are designed to help you achieve a trouble-free installation. Should you have any questions or require technical help at any time, please call our technical service group at (877) 612-5086 or +1 (610) 252-7301.

Note: To expedite assistance, all correspondence or communication **MUST** include the model number, serial number and complete and detailed explanation of the problem.

Before you begin

After uncrating and removing all packing material, inspect the equipment for concealed shipping damage. If damage is found, notify the shipper immediately and contact Follett Corporation so that we can help in the filing of a claim, if necessary.

Check your paperwork to determine which model you have. Follett model numbers are designed to provide information about the type and capacity of Follett equipment. Following is an explanation of the different model numbers in the 425 series.

MCD425ABT

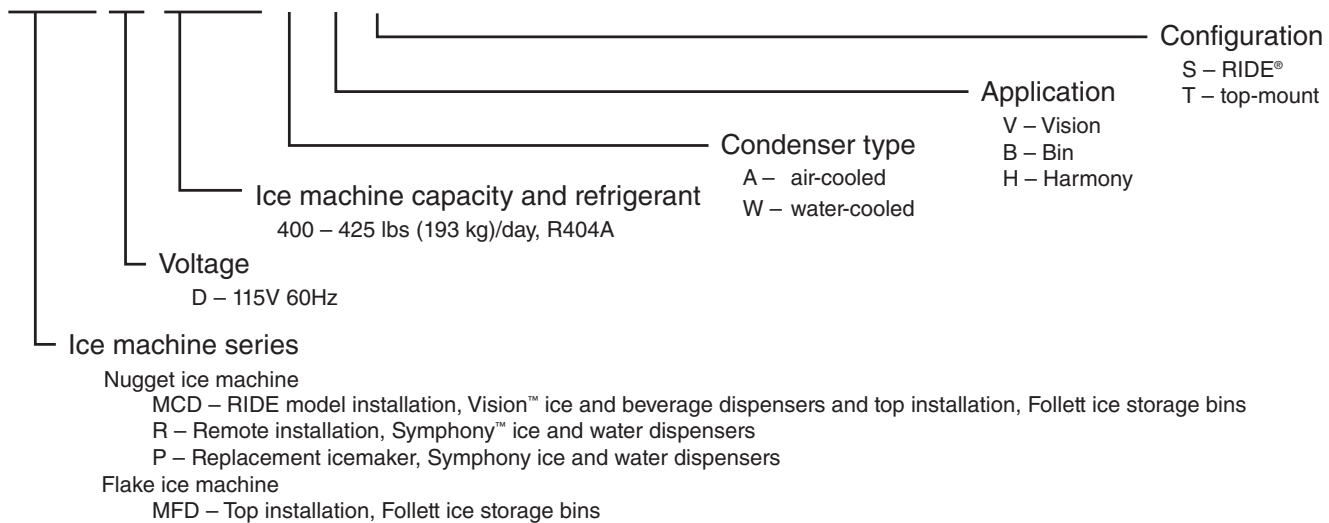

Important cautions

Moving parts. Do not operate with front cover removed.

Hot parts. Do not operate with cover removed.

To reduce risk of shock disconnect power before servicing.

Most ice machine cleaners contain citric or phosphoric acid, which can cause skin irritation. Read caution label on product and follow instructions carefully.

Ice is slippery. Maintain counters and floors around dispenser in a clean and ice-free condition.

Ice is food. Follow recommended cleaning instructions to maintain cleanliness of delivered ice.

Specifications

Electrical

- Each ice machine and dispenser require a separate circuit with electrical disconnect within 10 ft (6 m).
- Equipment ground required.
- Standard electrical – 115 V, 60 Hz, 1 phase.
- Connect to a dedicated 15A circuit.
- Maximum ice machine amperage – 11A each.
- Cord and plug provided on ice machine.

Plumbing

- 3/8" FPT water inlet
- 3/4" MPT drain
- 3/8" FPT condenser inlet (water-cooled condenser only)
- 3/8" FPT condenser drain (water-cooled condenser only)

Notes:

- Slope to drain of 1/4" per foot (6 mm per 30.4 cm run) with a 1/2" min. is recommended.
- Water shut-off recommended within 10 feet (3 m), drain to be hard piped and insulated.
- Separate drains for ice machine and condenser. To prevent back flow, do NOT connect drains.
- Follett recommends a Follett water filter system be installed in the ice machine inlet water line (standard capacity #00130229, high capacity #00978957, carbonless high capacity #01050442).

Ambient

Air temperature*	100 F/38 C max.	50 F/10 C min. (best performance below 80 F/27 C)
Water temperature†	90 F/32 C max.	45 F/10 C min. (best performance below 70 F/21 C)
Water pressure	70 psi max. (482 kPA)	10 psi min. (68 kPA)
Condenser water temperature	90 F/32.2 C max.	45 F/7.2 C min
Condenser water pressure	125 psi (862 kPA) max.	10 psi (68 kPA) min.

* Ambient air temperature is measured at the air-cooled condenser coil inlet.

† Ambient water temperature is measured in the ice machine reservoir.

Water usage (water-cooled condenser only)

- 0.25 gpm @ 50 F (10 C)
- 0.5 gpm @ 70 F (21 C)
- 1.25 gpm @ 90 F (32 C)

Dimensions and clearances

- Entire front of ice machine must be clear of obstructions/connections to allow removal.
- 12" (30.5 cm) clearance above ice machine for service.
- 6" (15.3 cm) minimum clearance between exhaust side of ice machine and any adjacent equipment.
- MCD425A & R425A – 18" (45.7 cm) minimum, 10 ft (3 m) maximum clearance between discharge and air intake grilles.

MCD425A/W_T MFD425A/W_T

Front view — top mount

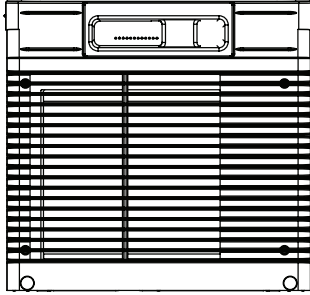

Side view — top mount

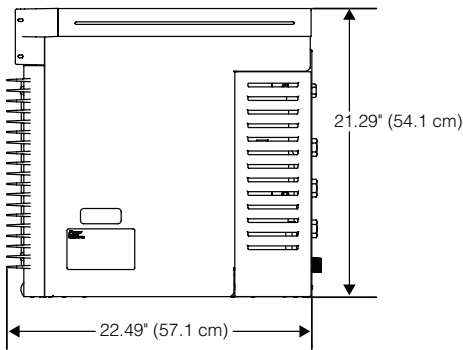

Back view — top mount

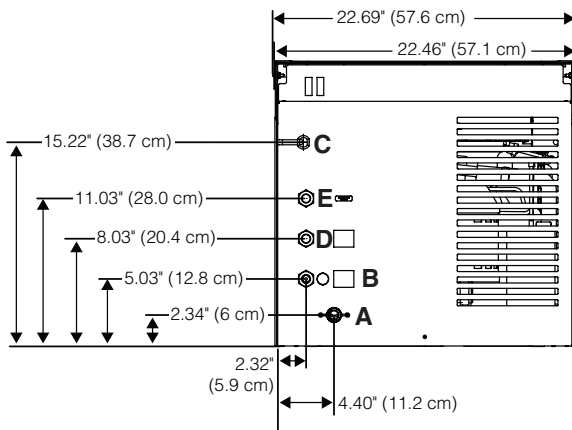

MCD425A/W_S R425A/W

Front view — air-cooled

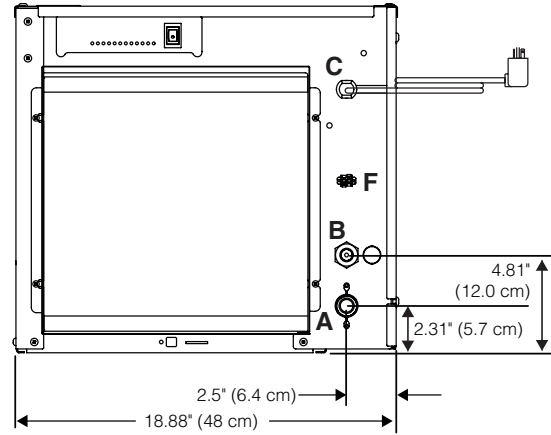

Front view — water-cooled

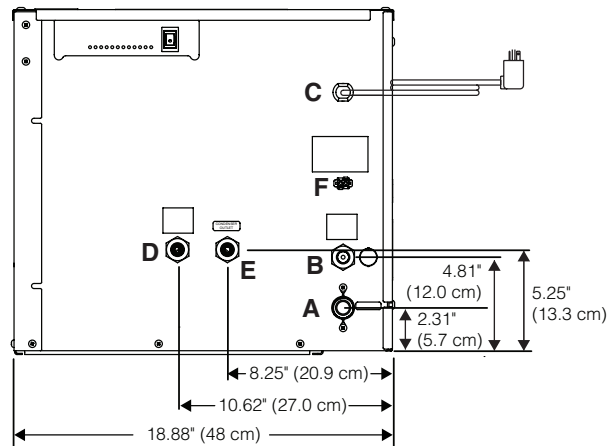

Side view — air-cooled and water-cooled

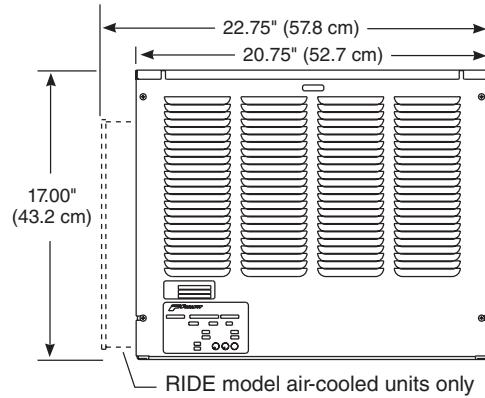

A – 3/4" MPT drain
B – 3/8" FPT water inlet
C – Electrical cord

D – 3/8" FPT condenser inlet
E – 3/8" FPT condenser drain
F – Bin signal connection (DO NOT APPLY VOLTAGE!)

Operation

Cleaning/descaling and sanitizing

Follett ice machines and dispensers, and their associated cleaning and sanitizing procedures, are designed for use with potable water sources. The presence, or suspected presence, of infectious agents may call for additional measures, including the replacement of components and more comprehensive disinfection measures. Follett recommends that these cleaning and sanitizing procedures be reviewed with the appropriate infectious agent subject matter experts to assure complete remediation.

Periodic cleaning/descaling and sanitizing of Follett's ice machine system is required to ensure peak performance and delivery of clean, sanitary ice. The recommended cleaning procedures that follow should be performed at least as frequently as recommended and more often if environmental conditions dictate.

Cleaning of the condenser can usually be performed by facility personnel. Cleaning/descaling and sanitizing of the ice machine system should be performed by your facility's trained maintenance staff or a Follett authorized service agent. Regardless of who performs the cleaning, it is the operator's responsibility to see that this cleaning is performed according to the schedule below. Service problems resulting from lack of preventive maintenance will not be covered under the Follett warranty.

Symphony Plus	Frequency
Drain Line	weekly
Drain Pan/Drip Pan	weekly
Exterior, Water Station Tube	as needed
Condenser	monthly (air-cooled only)
Ice Machine	semi-annually
Transport Tube	semi-annually

* Ice machine must be sanitized prior to start-up.

Weekly

The exterior may be cleaned with a stainless cleaner such as 3M* Stainless Steel Cleaner & Polish or equivalent.

* 3M is a trademark of 3M Company.

Monthly

Condenser (air-cooled ice machine only)

1. Use a vacuum cleaner or stiff brush to carefully clean condenser coils of lint and debris to ensure optimal performance.
2. When reinstalling counter panels in front of RIDE model ice machines, be sure that ventilation louvers line up with condenser air duct.

Semi-Annually (more often if conditions dictate)

- A cleaning/descaling and sanitizing procedure should always include both the ice machine and bin/dispenser.
- Icemaking system can be cleaned/descaled in place.

Cleaning & Sanitizing Tool Checklist

- (2) 1.5 gallon (or larger) plastic buckets
- (2) clean cloths
- Sanitary gloves
- Safety glasses
- (2) Sani-Sponge™ (P/N 00131524 - single sponge)
- (1) Packet of SafeCLEAN™ (P/N 00132001 - 24 packets)
- 1.6 fl oz. of Nu-Calgon IMS-II or IMS-III Sanitizer (P/N 00979674 - 16 fl. oz. bottle)

 **CAUTION!**

- Wear rubber gloves and safety goggles (or face shield) when handling cleaner or sanitizer mixtures.
- Use only Follett approved cleaners.
- It is a violation of Federal law to use the Cleaning or Sanitizing solution in a manner inconsistent with their labeling.
- Do not use solvents, abrasive cleaners, metal scrapers or sharp objects to clean any part of the dispenser.

Cleaning Solution: Mix cleaning solution of 1 gal. (3.8 L) 100 F (38 C) water and 7 oz. (198 g) (one 7 oz. packet) of Follett SafeCLEAN ice machine cleaner/descaler (P/N 00132001).

Sanitizing Solution: Mix a sanitizing solution of 1 gal. (3.8 L) 100 F (38 C) water and 1.6 oz. (47 ml) Nu-Calgon IMS-II or IMS-III Sanitizer (P/N 00979674).

Cleaning/descaling procedure

Note: Check drains and drain cup to ensure they are open and flowing freely.

1. If ice machine was running recently, ensure that the evaporator is completely free of ice before proceeding. If there is ice in the evaporator, complete steps 2-7 using only hot water to remove the ice then begin Cleaning/Descaling Procedure again.
2. Remove front or top cover.
3. Disconnect bin signal cable from ice machine electrical box.
4. Press CLEAN switch. The MAINTENANCE light will turn on and the machine will drain. Wait for the LOW WATER light to turn on.
5. Remove lid from cleaning cup and fill (about 1 quart) until cleaning solution completely fills the reservoir. Place lid back on cup.
6. CLEANER FULL light will turn on and machine will start cleaning cycle then rinse three times; this process takes approximately 15 minutes.
7. When machine is finished cleaning, the MAINTENANCE light will turn off.

Sanitizing Procedure

8. Press CLEAN switch. The MAINTENANCE light and LOW WATER light will turn on.
9. Fill cleaning cup with sanitizing solution until completely fills the reservoir. Place lid back on cup. Save remainder of sanitizing solution.
10. CLEANER FULL light will turn on and machine will start sanitizing cycle then rinse three times; this process takes approximately 15 minutes.
11. When machine is finished rinsing, the MAINTENANCE light will turn off. Remove top bearing insulation and nozzle insulation, then loosen phillips-head screw on nozzle connected to evaporator. Remove nozzle from evaporator side only, leave other side of nozzle connected to transport tube.
12. Place one Sani-Sponge in remaining sanitizing solution.
13. Insert the sponge soaked in sanitizing solution into nozzle then insert a dry sponge into the nozzle.
14. Replace nozzle onto evaporator and tighten screw. Ensure drain is connected to reservoir and vent tubes are connected to evaporator drain pan.
15. Reconnect bin signal cable. Wait for ice to push sponges through transport tube.
16. Collect sponges from ice storage bin.
17. Replace front or top cover.
18. After 10 minutes, dispense all ice and discard.
19. Clean/descale and sanitize dispenser/bin.

User Interface and Exterior Cabinet

- Clean stainless steel panels with stainless steel cleaner.

Service

Ice machine Operation (all models)

Follett's ice machine consists of four distinct functional systems:

- Harvesting system
- Water system
- Electrical control system
- Refrigeration system

These four systems work together to accomplish the production and harvesting of ice. A problem in any one of these systems will result in improper operation of the entire ice production cycle. When troubleshooting the ice machine, it is important to analyze the entire system operation to determine which system is not functioning properly, then pinpoint the component within that system that is malfunctioning. Determine what corrective action must be taken before making any adjustments or replacing any components.

The icemaking process

The Maestro Plus ice machine uses a stainless steel jacketed evaporator and operates on a continuous freezing cycle. Water is supplied to the evaporator from the water reservoir where the water level is controlled by a float valve. This valve also shuts off the water supply when the ice machine is not running.

When the ice machine is running, a layer of ice forms on the interior surface of the evaporator. This ice is continuously removed by a slowly rotating (12 RPM) auger. The auger carries the ice upward into the cavity formed by the top bearing housing and the compression loop, where it is compressed to remove excess water. When the ice reaches the desired hardness it rotates within the cavity and is forced through a discharge port and compression nozzle and into the ice transport tube. The discharge tube and compression nozzle are slightly restricted to further compress the ice and produce the desired hardness.

A solid state control board located in the electrical box of the ice machine controls the normal operation of the ice machine and monitors gearmotor torque. This control board will shut down the ice machine should an over-torque condition occur. It is very important that you familiarize yourself with the operational sequences detailed in this manual before attempting to service the ice machine.

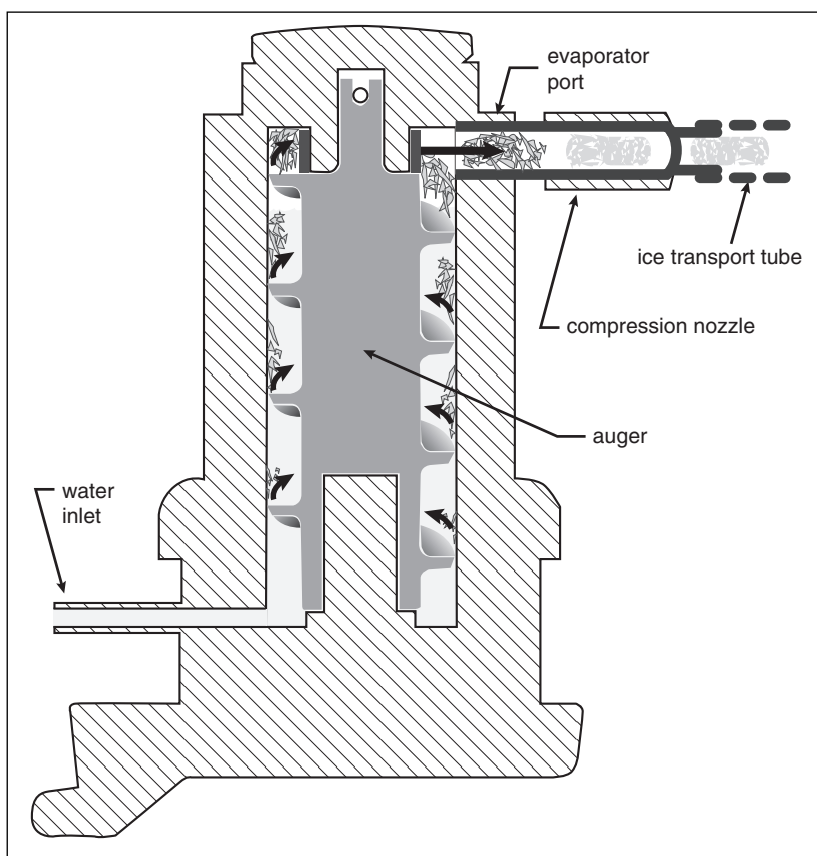

Water system

The water level in the evaporator is controlled by a fill solenoid (**Fig 1**) and level detecting sensors. Water sensing rods (**Fig. 2**) extend down into the reservoir at the end of the evaporator assembly. The system works via electrical conductivity as follows:

One of the longest probes is a common. When water is between any of the other probes and the common, the PC board will sense the activation. During normal operation, the water level rises and falls between the Normal High and Normal Low sensors. As water is consumed to make ice, the level will fall until the Normal Low sensor is exposed, triggering the water feed solenoid on. Water will fill until the Normal High sensor is activated.

Note: The potable water dissolved solids content must be greater than 10 ppm for the water control system to function properly. If using reverse osmosis water filtration system, ensure T.D.S level is greater than 10 ppm.

Fig. 1 Water system diagram

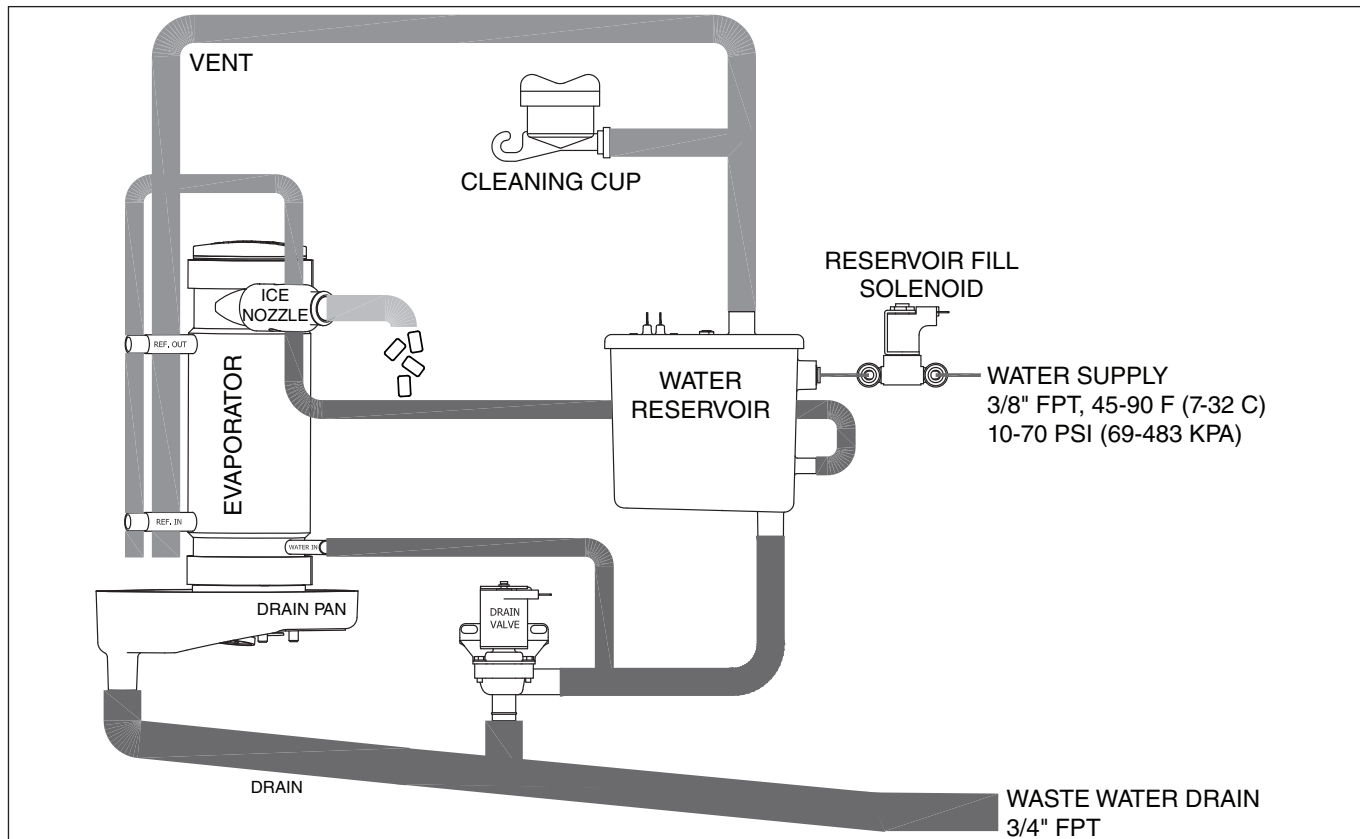
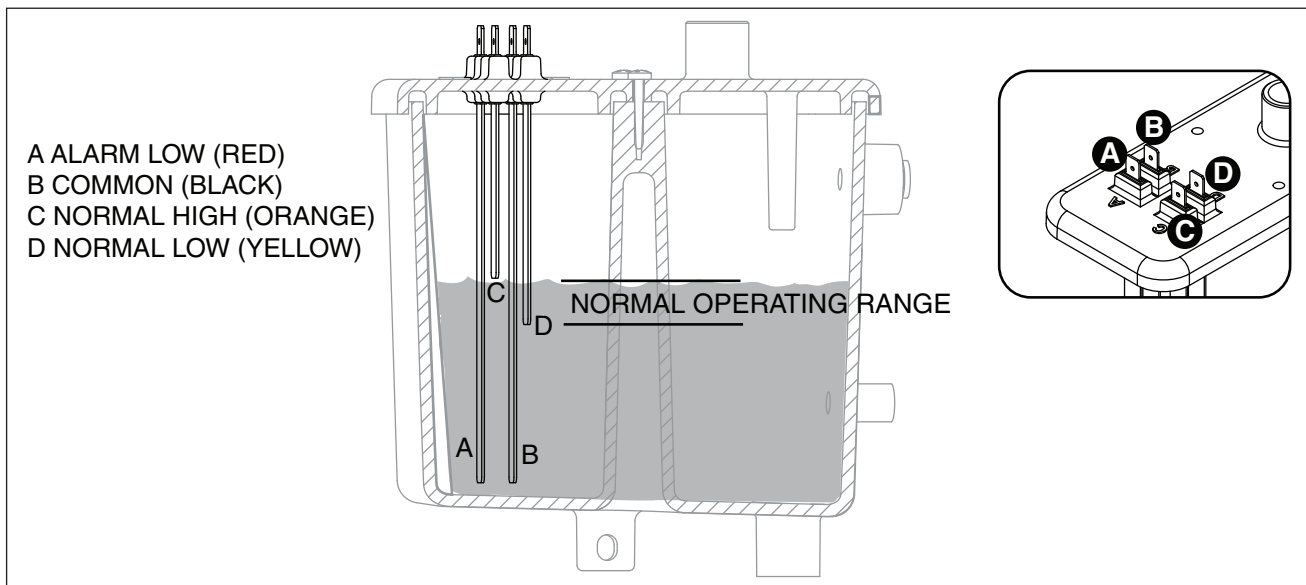

Fig. 2 Water level diagram



Electrical system



ATTENTION!

To prevent circuit breaker overload, wait 15 minutes before restarting this unit. This allows the compressor to equalize and the evaporator to thaw.

Normal control board operation

The PC board indicator lights provide all the information necessary to determine the machine's status. Green indicator lights generally represent "go" or normal operation; Yellow indicators represent normal off conditions; Red indicators generally represent alarm conditions, some of which will lock the machine off.

A flashing green light labeled POWER indicates power to the machine. All other normal operation status indicators are covered as follows:

Ice machine disposition	Operating conditions
Legend: ● ON ○ OFF ◐ ON or OFF ✖ FLASHING	
1. Ice machine is making ice. CLEANER FULL ○ DRAIN CLOG ○ HI PRESS ○ HI AMPS ○ SERVICE ○ MAINT/CLEAN ○ LOW WATER ○ TIME DELAY ○ SLEEP CYCLE ○ MAKING ICE ● LOW BIN ● POWER ON ✖	1. Normal running.
2. Ice machine is not making ice. CLEANER FULL ○ DRAIN CLOG ○ HI PRESS ○ HI AMPS ○ SERVICE ○ MAINT/CLEAN ○ LOW WATER ○ TIME DELAY ● SLEEP CYCLE ○ MAKING ICE ○ LOW BIN ◐ POWER ON ✖	2. Normal time delay. When the bin fills with ice, the LOW BIN light goes out momentarily and the refrigeration and auger drive systems immediately shut down. (Note: The fan motor will continue to run for 10 minutes to cool condenser) The TIME DELAY light comes on, initiating the time delay period. When the time delay expires, the machine will restart provided that the LOW BIN light is on.

DIP Switch Settings

OFF POSITION ON POSITION

MCD425A/W_T, MCD425A/W_S, R425A/W

OFF	ON		OFF	ON
[Sleep cycle disabled]	→ <input type="checkbox"/>	NO	[Sleep cycle enabled]	→ <input checked="" type="checkbox"/>
Not used	↷ <input type="checkbox"/>		Not used	↷ <input type="checkbox"/>
[Sleep cycle dispense duration]	↖ <input type="checkbox"/>		[Sleep cycle dispense duration]	↖ <input checked="" type="checkbox"/>
20 min. time delay	5 <input type="checkbox"/>		60 min. time delay	5 <input checked="" type="checkbox"/>
Flush disabled	6 <input type="checkbox"/>		Flush enabled	6 <input checked="" type="checkbox"/>
Maint. timer ON	7 <input type="checkbox"/>	DIP	Maint. timer OFF	7 <input checked="" type="checkbox"/>
	8 <input type="checkbox"/>			8 <input checked="" type="checkbox"/>

425A/W installed in Symphony Plus 25/50/110 CI, CT, or FB

OFF	ON		OFF	ON
[Sleep cycle disabled]	→ <input checked="" type="checkbox"/>	ON	[Sleep cycle enabled]	→ <input type="checkbox"/>
Not used	↷ <input type="checkbox"/>		Not used	↷ <input type="checkbox"/>
[Sleep cycle dispense duration]	↖ <input type="checkbox"/>		[Sleep cycle dispense duration]	↖ <input checked="" type="checkbox"/>
20 min. time delay	5 <input type="checkbox"/>		60 min. time delay	5 <input checked="" type="checkbox"/>
Flush disabled	6 <input type="checkbox"/>		Flush enabled	6 <input checked="" type="checkbox"/>
Maint. timer ON	7 <input type="checkbox"/>	DIP	Maint. timer OFF	7 <input checked="" type="checkbox"/>
	8 <input type="checkbox"/>			8 <input checked="" type="checkbox"/>

Replacement P425A/W installed in Symphony dispenser

OFF	ON		OFF	ON
[Sleep cycle disabled]	→ <input type="checkbox"/>	NO	[Sleep cycle enabled]	→ <input checked="" type="checkbox"/>
Not used	↷ <input type="checkbox"/>		Not used	↷ <input type="checkbox"/>
[Sleep cycle dispense duration]	↖ <input type="checkbox"/>		[Sleep cycle dispense duration]	↖ <input checked="" type="checkbox"/>
20 min. time delay	5 <input type="checkbox"/>		60 min. time delay	5 <input checked="" type="checkbox"/>
Flush disabled	6 <input type="checkbox"/>		Flush enabled*	6 <input checked="" type="checkbox"/>
Maint. timer ON	7 <input type="checkbox"/>	DIP	Maint. timer OFF	7 <input checked="" type="checkbox"/>
	8 <input type="checkbox"/>			8 <input checked="" type="checkbox"/>

Sleep cycle dispense duration

OFF	ON		OFF	ON	
4	<input type="checkbox"/>	35 s	4	<input checked="" type="checkbox"/>	5 s
5	<input type="checkbox"/>		5	<input type="checkbox"/>	
4	<input type="checkbox"/>	15 s	4	<input checked="" type="checkbox"/>	60 s
5	<input checked="" type="checkbox"/>		5	<input type="checkbox"/>	

* Flush can be enabled on Symphony CT and FB models. Flush should be disabled on Symphony CI units due to risk of internal leak if drain line is blocked. All Symphony Plus models should be set to Flush enabled.

Relay/triac output indication

Each relay on the board has an indicator light associated with its output. For example, when the relay for the water feed solenoid is energized, the adjacent indicator light glows green.

Flushing logic

Off cycle: At the completion of off-cycle time delay, the machine checks for a cumulative one (1) hour of ice making time since the last off-cycle flush. If the cumulative ice making time exceeds one (1) hour, the machine will open the drain valve for 60 seconds to drain the evaporator in its entirety. It will then refill with water, flush again and refill, and begin making ice. If the ice making time is less than 1 hour, the machine will start and begin making ice without draining the evaporator.

Error faults

The Maestro Plus PC board monitors various operating parameters including high pressure, auger gearmotor amperage limits, clogged drain, and low water alarm conditions. There are two types of errors namely "hard" or "soft." A hard error is one that shuts the machine off and will not allow restart until the reset button is pressed. Even cycling power will not reset a hard error. A soft error can either be automatically reset should the condition rectify, or if power is cycled. Should an error occur, consult the troubleshooting guide in this manual or a Follett service technician.

Soft errors:

Note: For all soft errors, the ice machine will remain off for 1 hour.

LO WATER: During operation, the water level cycles between the normal low and normal high sensors. Should the water be shut off to a running machine, a soft error will occur. The error sequence is as follows: During operation, the water level falls to the normal low sensor, and when it does the water feed solenoid is energized. If water is not detected at the normal low sensor within 10 seconds, a soft error will occur. The machine will shut down and TIME DELAY and LOW WATER LEDs will be lit. After time delay, the solenoid will energize and remain energized until the water level is sufficient for restart.

HI PRESSURE: Should the refrigeration pressure rise above 425 psi, the machine will shut down and the TIME DELAY and HIGH PRESSURE will be illuminated. After the time delay, and if the pressure has fallen back below the reset point of 295 psi, the machine will restart and the TIME DELAY and HIGH PRESSURE will clear.

HI AMPS: The PC board monitors the amperage of the auger motor. Should the gear motor experience current draw above the allowable 3A limit or no current draw (0A), the machine will shut down and the TIME DELAY and HI AMP will be illuminated. After the time delay the machine will restart and the TIME DELAY and HI AMP will clear.

Hard error:

HI AMPS: If a second hi-amp error occurs within 1 hour of the initial hi-amp error, the ice machine will shut off and the reset on the board must be pressed to clear the error. If a second hi-amp has occurred, the HI AMP LED only will be illuminated.

DRAIN CLOG: The drain clog sensor, located in the evaporator drain pan will detect the presence of water just below the top edge of the pan. If water does not properly flow out of the internal or external drain lines it will backup into the drain pan (especially during a self-flushing purge cycle). Pressing the reset button will restart the ice machine.

Technical specifications (all models)

Refrigeration system diagram

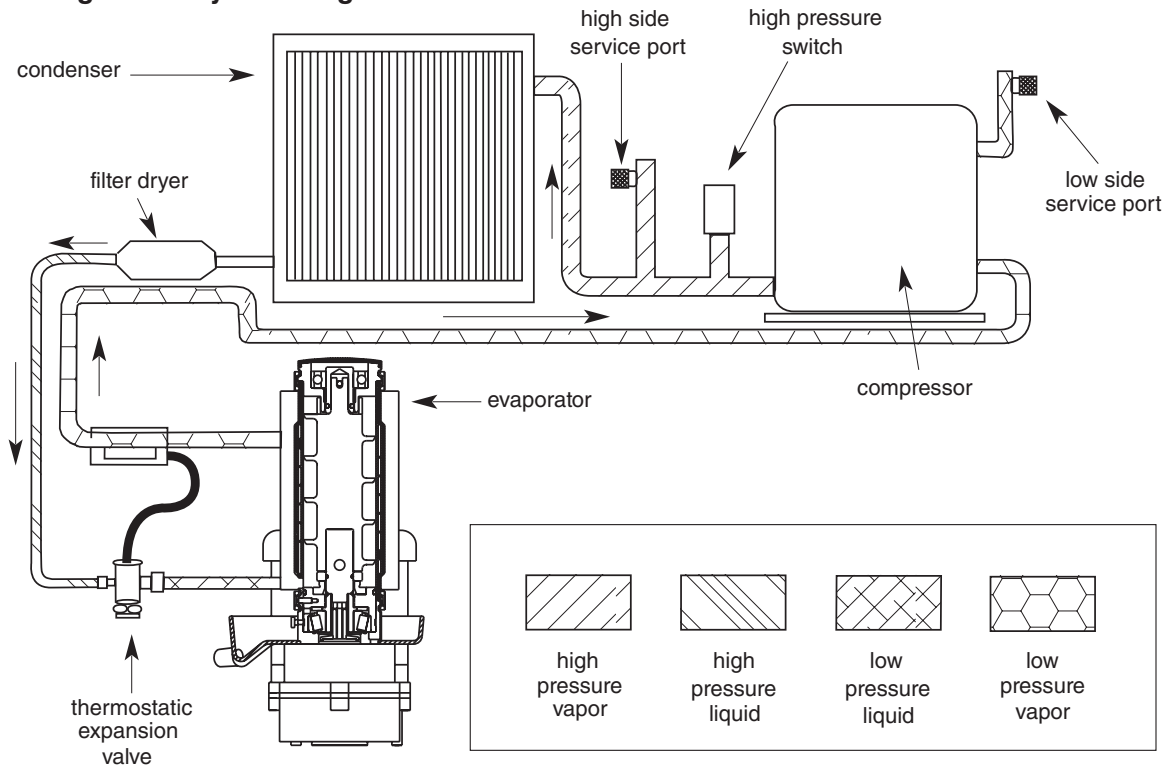

Refrigeration pressure data

- Water regulating valve is factory set at 300 (±10) PSIG head pressure.
- Readings within 10% of table values should be considered normal.

Compressor data

Locked rotor amps 58.8A

Compressor current draw

Air-cooled					
Ambient air temperature	60 F/15.6 C	70 F/21.1 C	80 F/26.7 C	90 F/32.2 C	100 F/37.8 C
Amperage	6.3A	6.5A	6.7A	6.9A	7.1A
High-side pressure (psi)	190	220	250	290	330
Low-side pressure (psi)	27	29	31	33	36
Water-cooled					
Water temperature at float	50 F/10 C	60 F/15.6 C	70 F/21.1 C	80 F/26.7 C	90 F/32.2 C
	5.6A	5.6A	5.7A	5.8A	5.8A

Water-cooled Ice Machine Refrigeration Pressure

Discharge Pressure/Suction Pressure

Condenser inlet water temperature °F/°C

Ice machine inlet water temperature °F/°C	°F/°C	50/10	70/21	90/32	
	50/10	280/27	285/29	290/31	psi
70/21	280/27	285/29	290/31	psi	
90/32	280/27	285/29	290/31	psi	

Gearmotor data

Gearmotor current
Locked rotor amps

Split-Phase

1.8A-1.9A (nominal)
14A

PSC (permanent split capacitor)

0.8A-0.9A (nominal)
7A-14A (temperature dependent)

Air-Cooled ice machine capacity/24hrs.

Ambient Air Temperature F/C

Inlet Water Temperature F/C	Ambient Air Temperature F/C					
	F	60	70	80	90	
C	16	21	27	32	38	
50	460	425	390	355	320	lbs.
10	208	193	177	161	145	kg.
60	437.5	405	372.5	340	307.5	lbs.
16	198	184	169	154	139	kg.
70	415	385	355	325	295	lbs.
21	188	175	161	147	134	kg.
80	405	375	345	315	285	lbs.
27	184	170	156	142	129	kg.
90	395	365	335	305	275	lbs.
32	179	166	152	138	125	kg.

Water-Cooled ice machine capacity/24hrs.

Condenser Water Temperature F/C

Inlet Water Temperature F/C	Condenser Water Temperature F/C						
	F	50	60	70	80	90	
C	10	16	21	27	32	38	
50	486	465	443	422	400	389	lbs.
10	220	211	201	191	181	176	kg.
60	464	445	425	406	386	367	lbs.
16	210	202	193	184	175	166	kg.
70	443	425	408	390	372	358	lbs.
21	201	193	185	177	169	162	kg.
80	422	406	389	373	356	340	lbs.
27	191	184	176	169	161	154	kg.
90	400	385	371	356	341	326	lbs.
32	181	175	168	161	155	148	kg.

Note: Nominal values - actual production may vary by $\pm 10\%$.

Electrical control system schematic

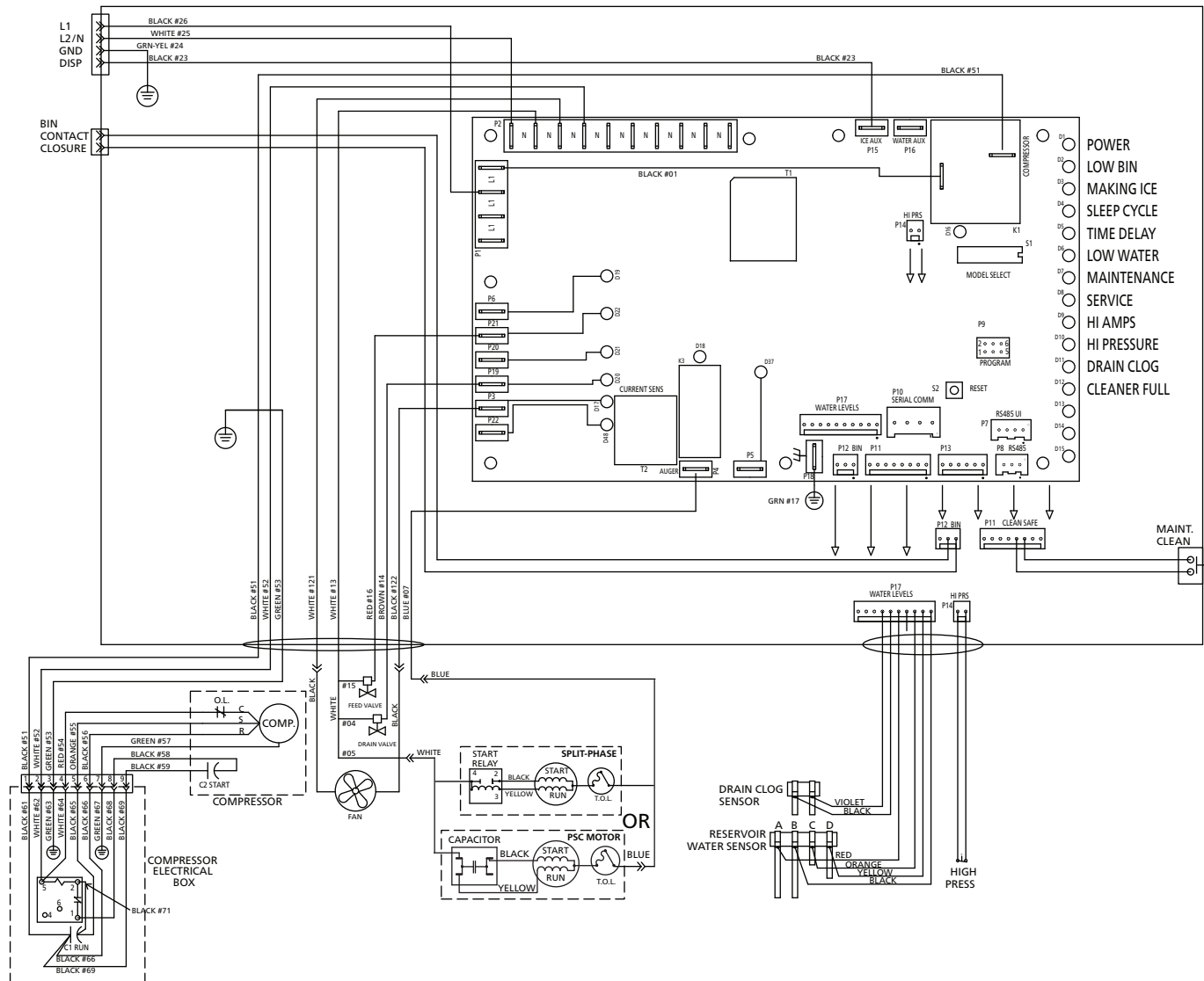

Electrical control system operation

The P425A/W, MCD425A/W_S and R425A/W wiring diagrams which follow illustrate the circuitry of Follett ice machines used with ice dispensers. Both normal operation of the ice machine (Stages 1–6) and non-normal diagnostic sequences showing torque-out (Stages 7–10) for use in troubleshooting ice machine problems are shown.

Circuitry notes

When the ice machine is used with a dispenser it receives power from the main power supply. Disconnect the power source before performing service. When performing electrical service, always use a meter to determine whether or not the components being serviced are energized.

- High pressure cutout opens at 425 PSI and closes at 287 PSI (auto reset).
- The bin signal input to the control board in the 425A/W ice machine must only be initiated by contact closure. Do not supply power. To run the ice machine in the workshop, use the bin signal jumper (P/N 01069095).

Note: The operation stage descriptions that follow are based on the unit containing the split-phase gear motor.

Normal operation – Stage 1

Power is supplied to L1 of the control board, the **POWER** LED light begins flashing. The ice level bin thermostat in the dispenser is closed and calling for ice, supplying contact closure to the control board. The **LOW BIN** LED will be on. The control board will now go through the start-up sequence. The board checks the water sensors (located in the reservoir) for continuity between the common probe (B) and the high probe (C). If continuity is not sensed, the water fill valve (P21) is energized.

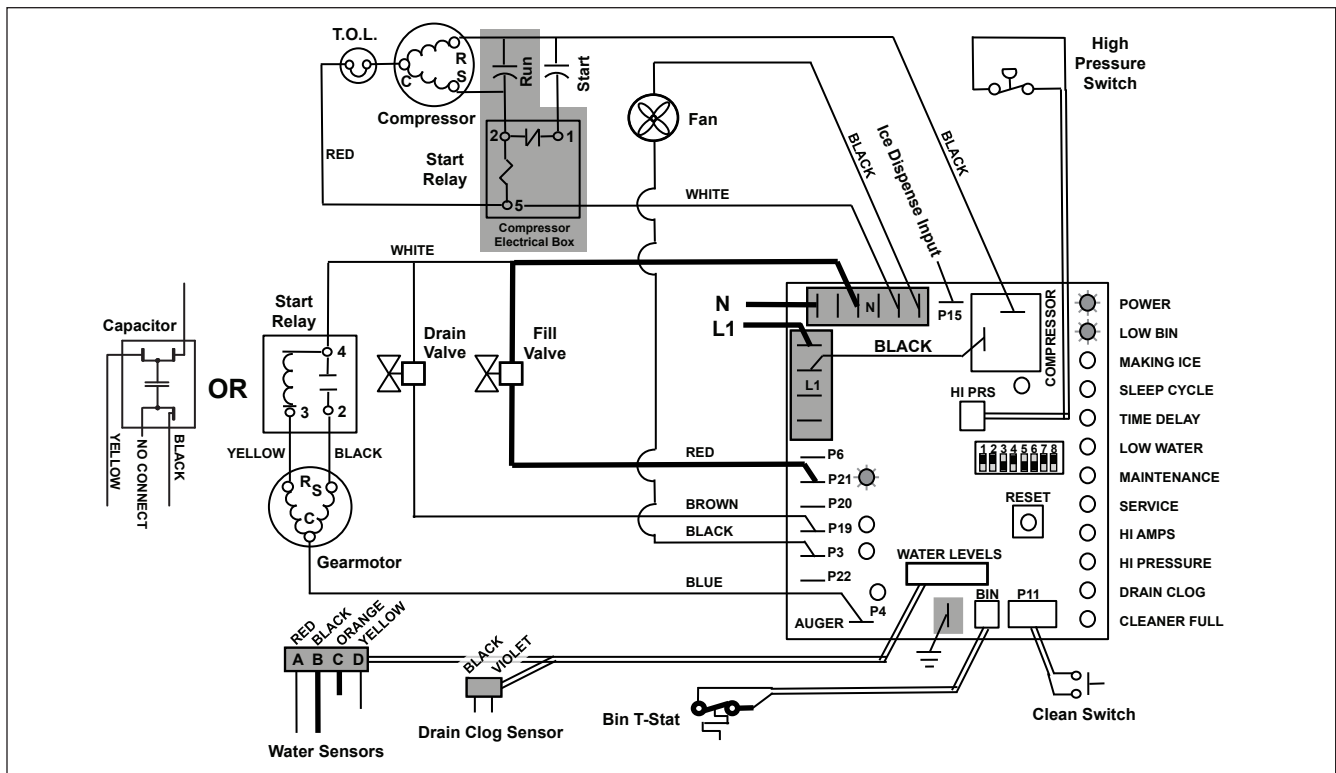

Normal operation – Stage 2

When continuity is seen between B and C, the water valve de-energizes, the AUGER output (P4) comes on along with the **MAKING ICE** LED. The auger gearmotor's start windings are energized through a current style start relay that is pulled in by the initial high current draw of the gearmotor.

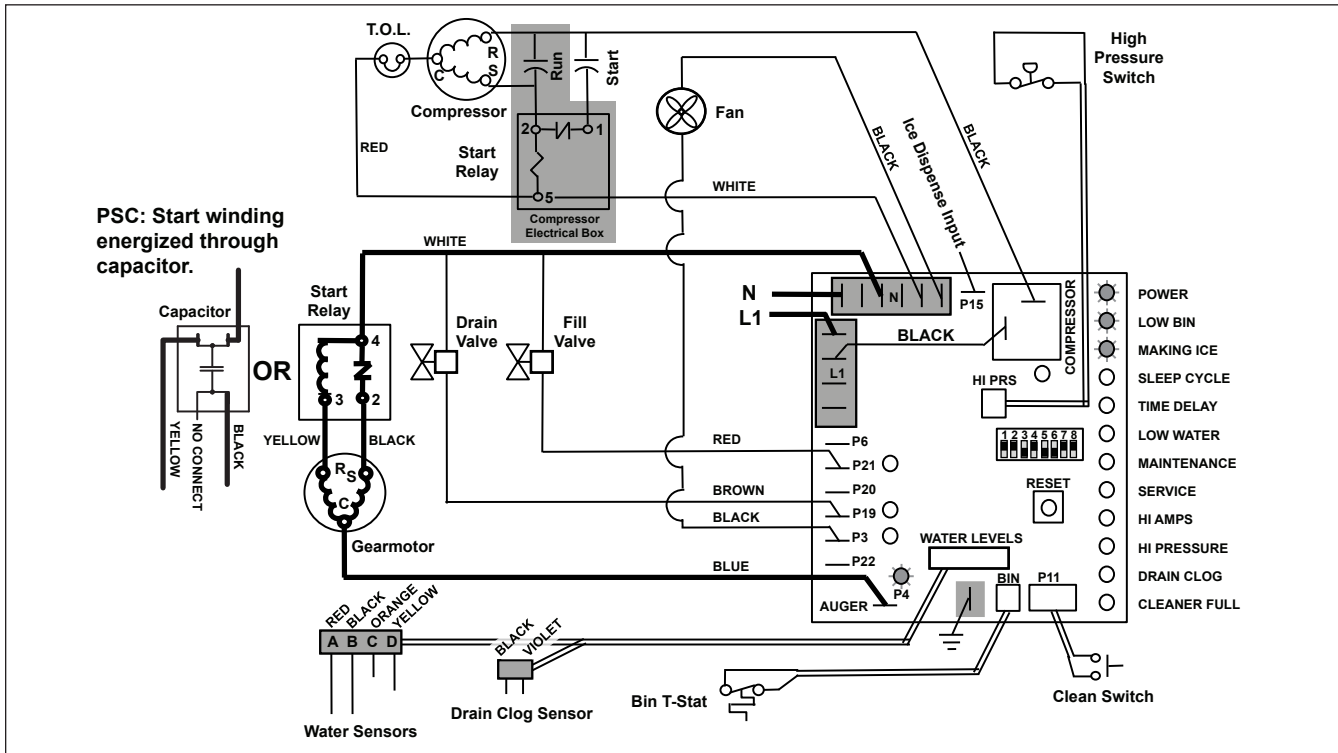

Normal operation – Stage 3

After the initial high current draw drops off, the gearmotor start relay contacts open, dropping out the start winding. The condenser fan output (P3) comes on 0.5 seconds later.

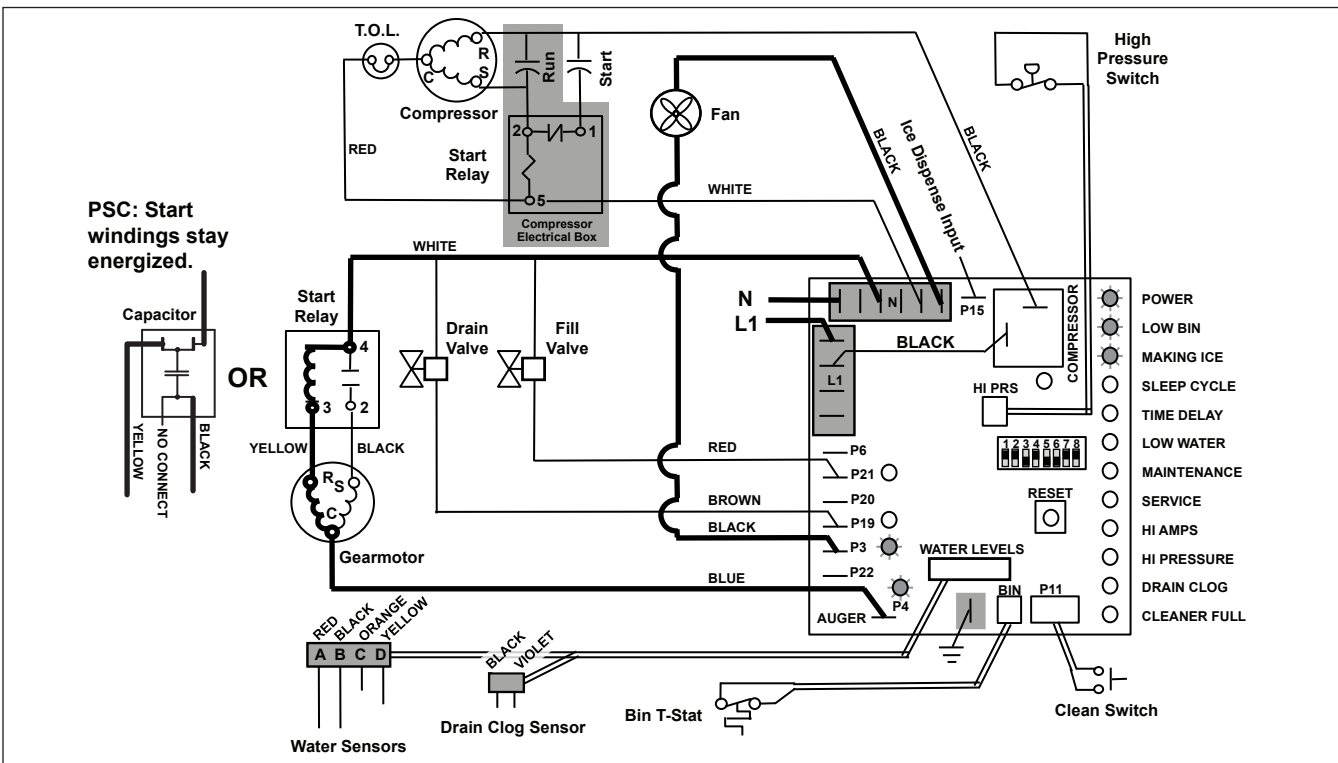

Normal operation – Stage 4

One second (1 s) after the fan comes on, the **COMPRESSOR** output comes on. The compressor circuit uses both run and start capacitors along with a potential start relay. The start capacitor is energized through the normally closed contacts of the start relay.

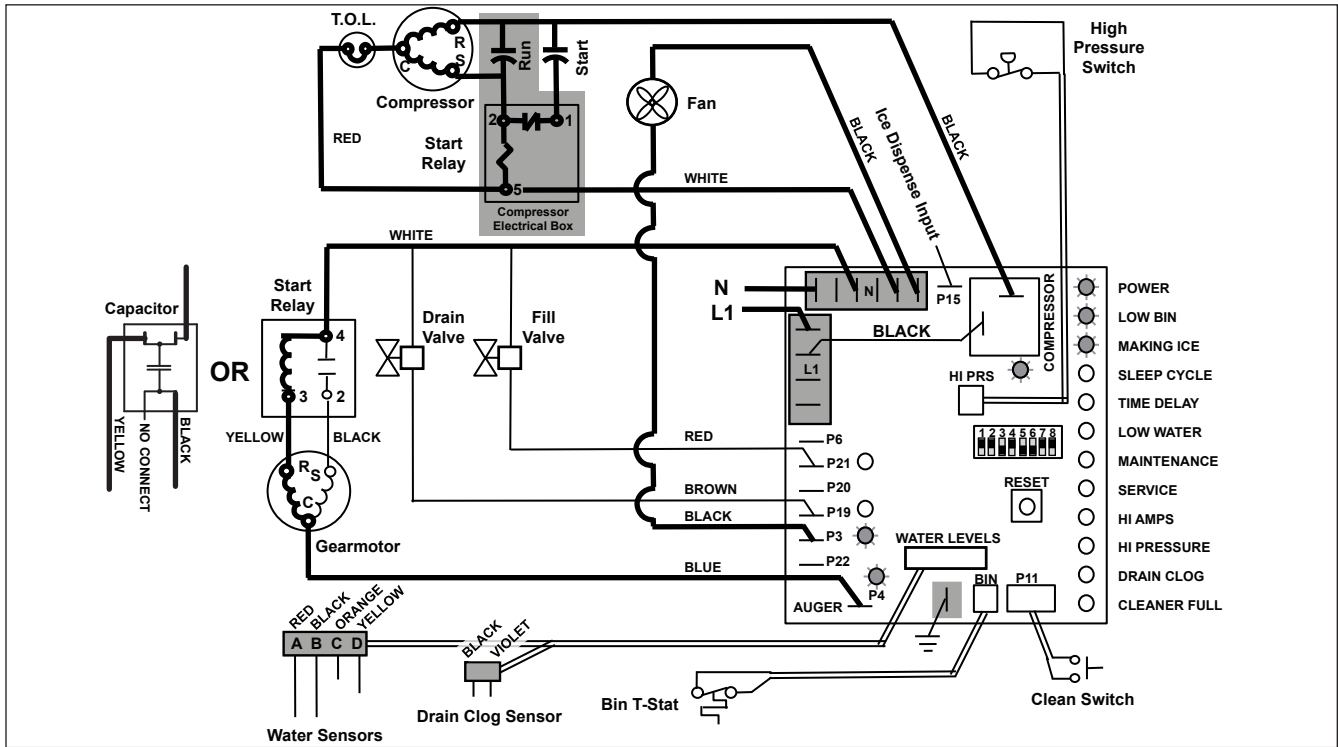

Normal operation – Stage 5

As the compressor comes up to normal running speed, its start winding generates a voltage potential across the relay's coil. This energizes the coil to open the contact and drop out the start capacitor.

The ice machine is now in a normal ice making mode. The ice machine will produce ice until the bin level control in the ice dispenser is satisfied.

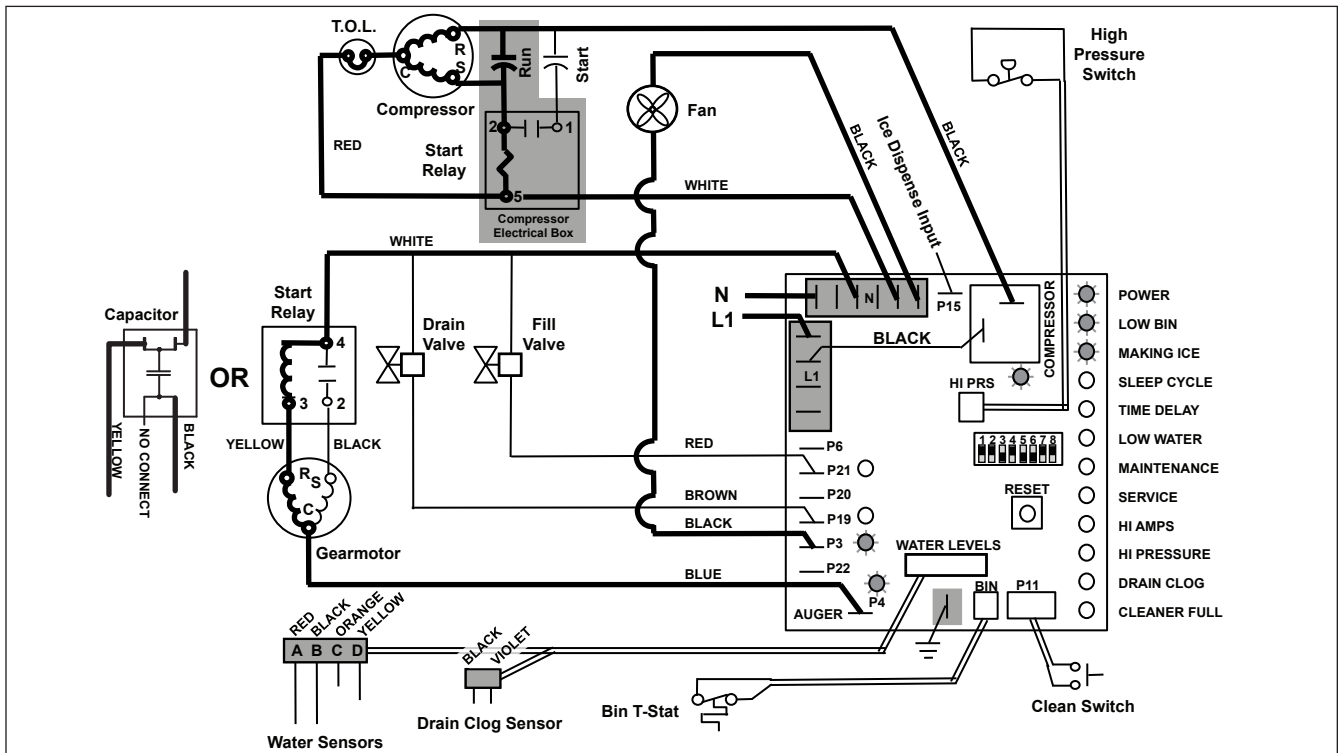

Normal operation – Stage 6

Once the bin thermostat control opens, the **LOW BIN** LED goes out. The compressor and gear motor outputs turn off, the **MAKING ICE** LED goes out and the **TIME DELAY** LED comes on. .

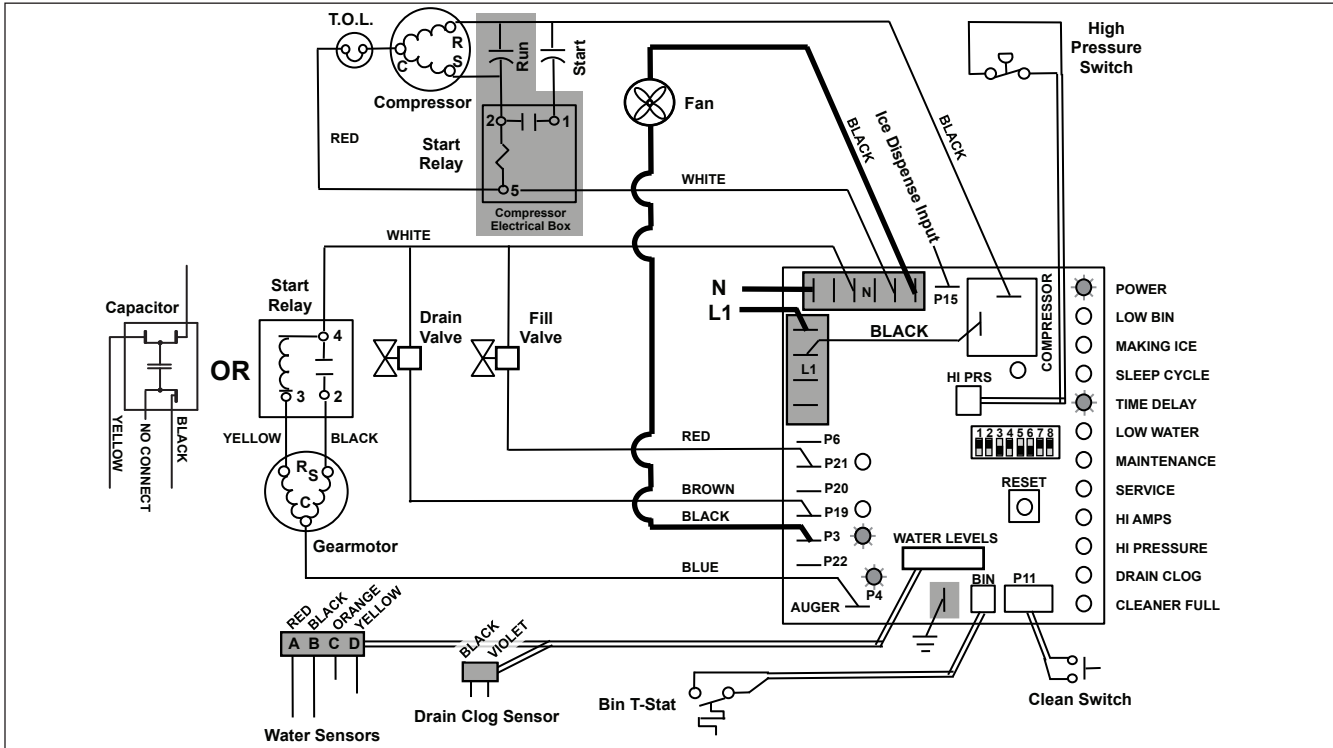

Normal operation – Stage 7

The fan motor continues for 10 minutes before shutting off. The **TIME DELAY** LED remains on for 20 minutes. The ice machine will not start while the **TIME DELAY** LED is on. To restart the ice machine for troubleshooting purposes, depress the reset button to clear the control board.

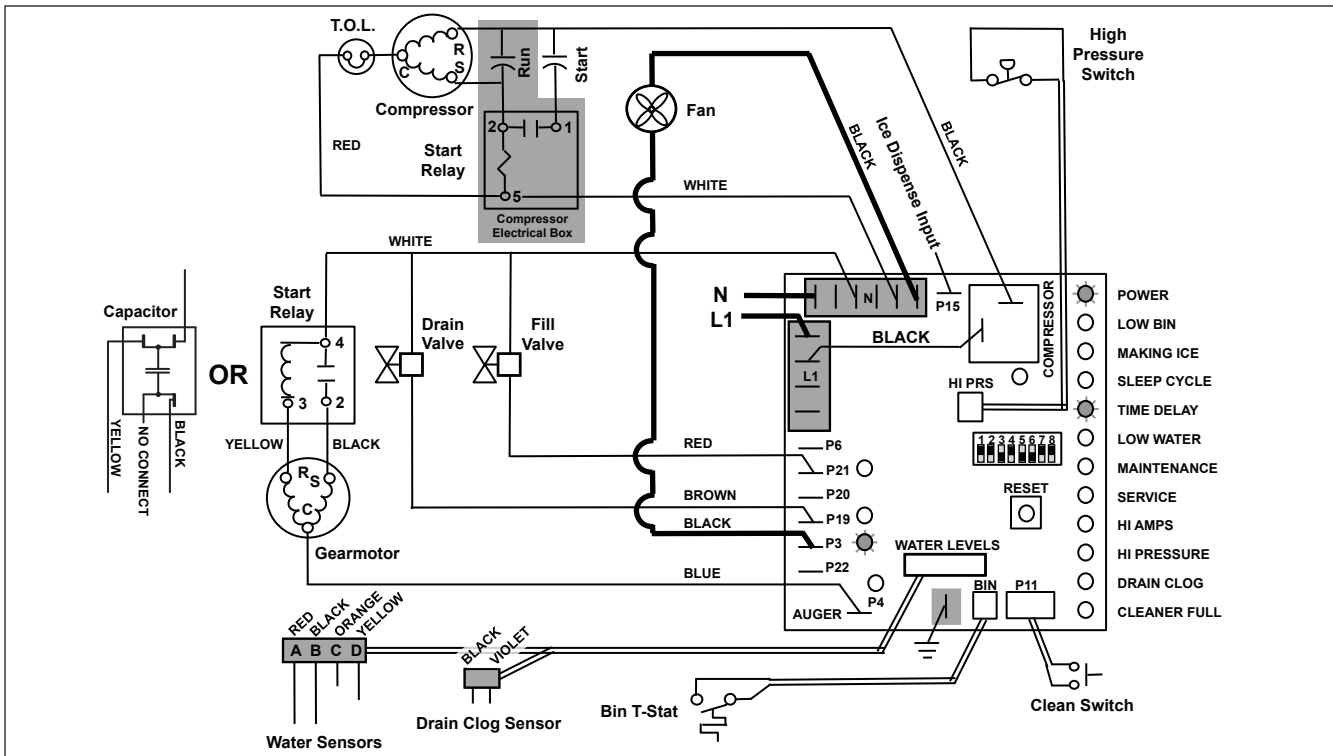

Normal operation – Stage 8

When the dwell time of 20 minutes has expired, the **TIME DELAY** LED goes off. If 5 seconds of ice has been dispensed and the **SLEEP CYCLE** LED (Symphony Plus only) is off, the ice machine will go through the normal start-up sequence when the bin level control signals the control board for ice.

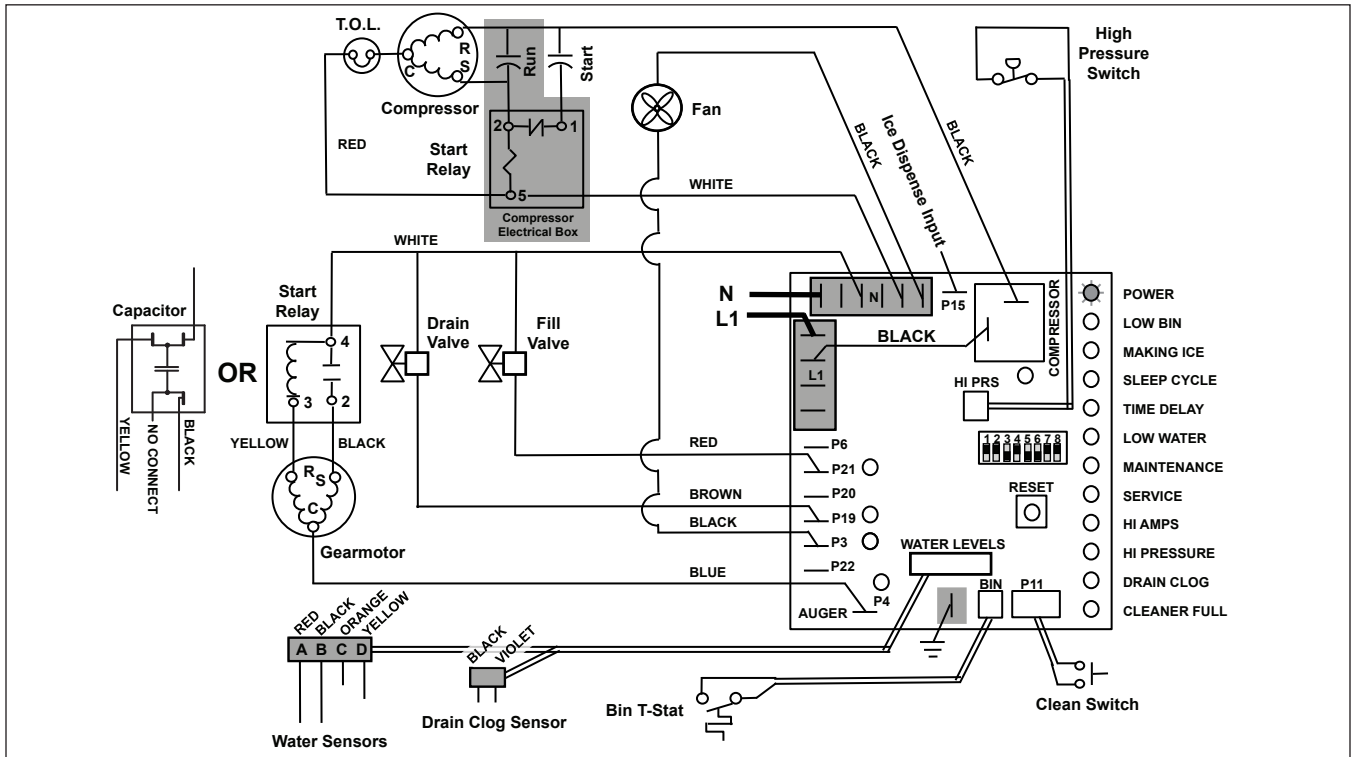

Quiet Night/Sleep cycle (Symphony Plus only)

The board monitors ice dispensing through a line voltage input to P15. If the ice dispense has not be initiated for more than 5 seconds during the 20 minute time delay, the **SLEEP CYCLE** LED comes on. The machine will stay off for 12 hours unless 5 seconds of dispensing is seen. After 12 hours, the **SLEEP CYCLE** LED goes out and the ice making will resume if the bin thermostat is closed. The sleep cycle dispense duration is adjustable using the DIP switches on the control board.

Self-flushing (when enabled)

At the completion of the 20 minute time delay, the machine checks for a cumulative one hour of ice making time since the last off-cycle flush. If the cumulative ice making time exceeds one hour, the machine will energize the drain valve P19 for 60 seconds to drain the evaporator. It will then refill with water, flush again, refill and begin making ice if the **LOW BIN** LED is on. If the ice making time is less than 1 hour, the machine will start and begin making ice without draining the evaporator.

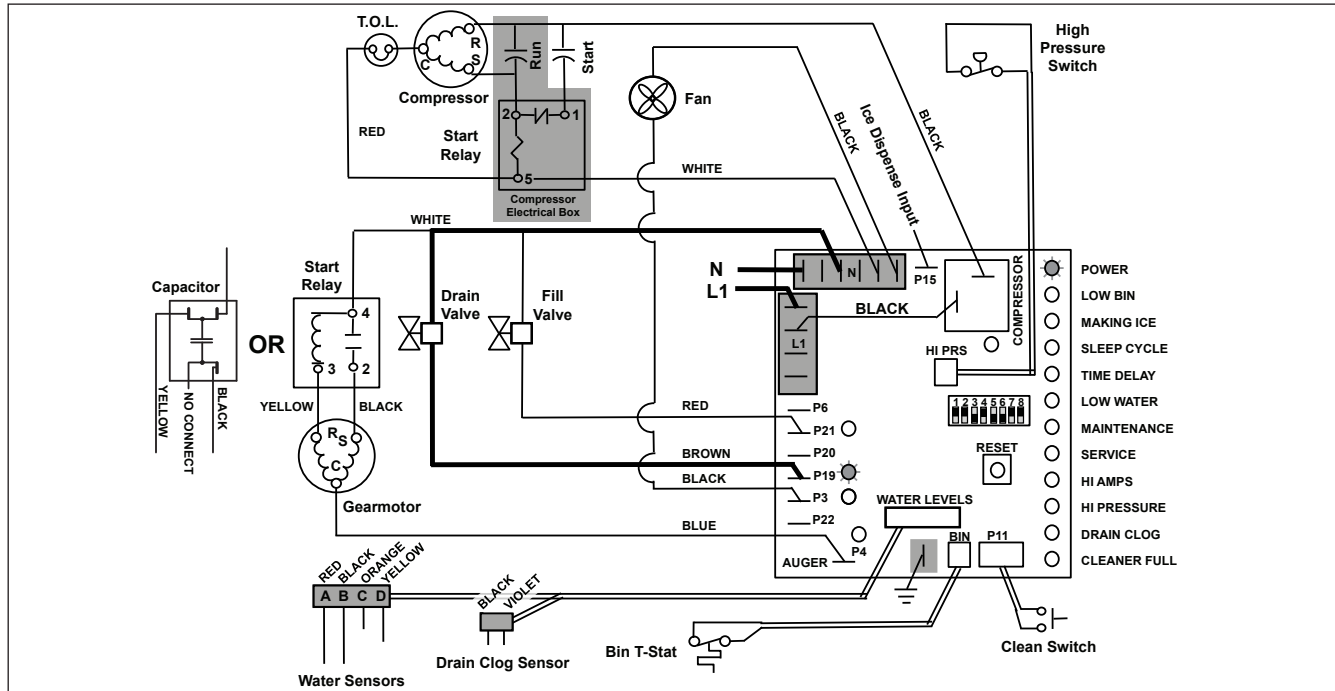

Diagnostic Stages

High gearmotor amps – Stage 1

The **HI AMPS** error and **TIME DELAY** LEDs are on indicating that the control board has sensed an over-torque condition at the P4 terminal (more than 3 amps from the gearmotor) or no current draw (0A) and shut the ice machine down (strike one). The **HI AMPS** and **TIME DELAY** LEDs will remain on for 60 minutes after an over-torque condition has occurred. The ice machine will remain off as long as these two LEDs are on. After the 60 minute time delay, these LED lights turn off, and the control board will try to go through a normal start-up sequence.

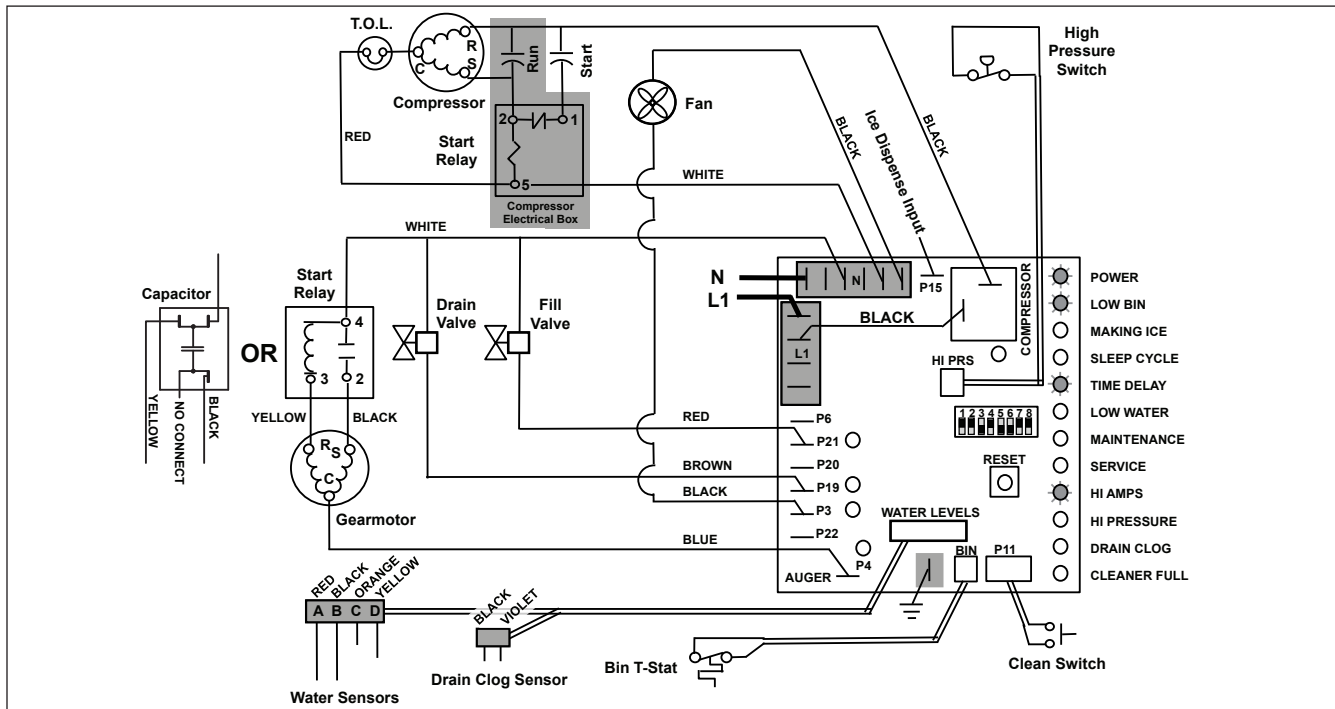

High gearmotor amps – Stage 2

If the restart is successful the board will continue to monitor the current draw on P4 for 60 minutes looking for a second high amps (above 3A) occurrence. If the ice machine runs without problems for 60 minutes and no additional torque errors occur, the ice machine will continue normal operation.

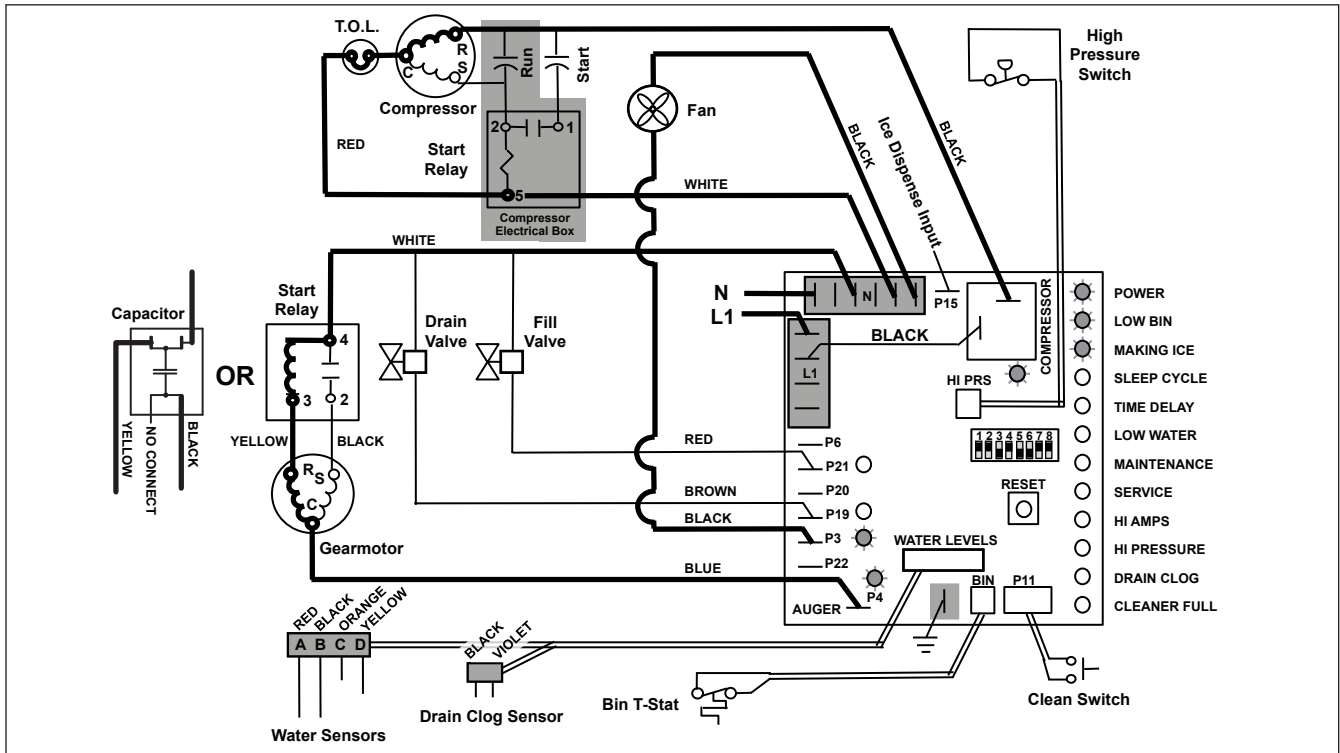

High gearmotor amps – Stage 3

If a second occurrence happens during the 60 minute monitoring period, the **HI AMPS** LED will come on again and shut the machine down (strike two). The **HI AMPS** LED (without the **TIME DELAY** LED) will indicate to the technician that two consecutive over-torque situations have occurred. The ice machine is shut down at this time and locked out. It will not restart unless the manual reset button is depressed while power is on.

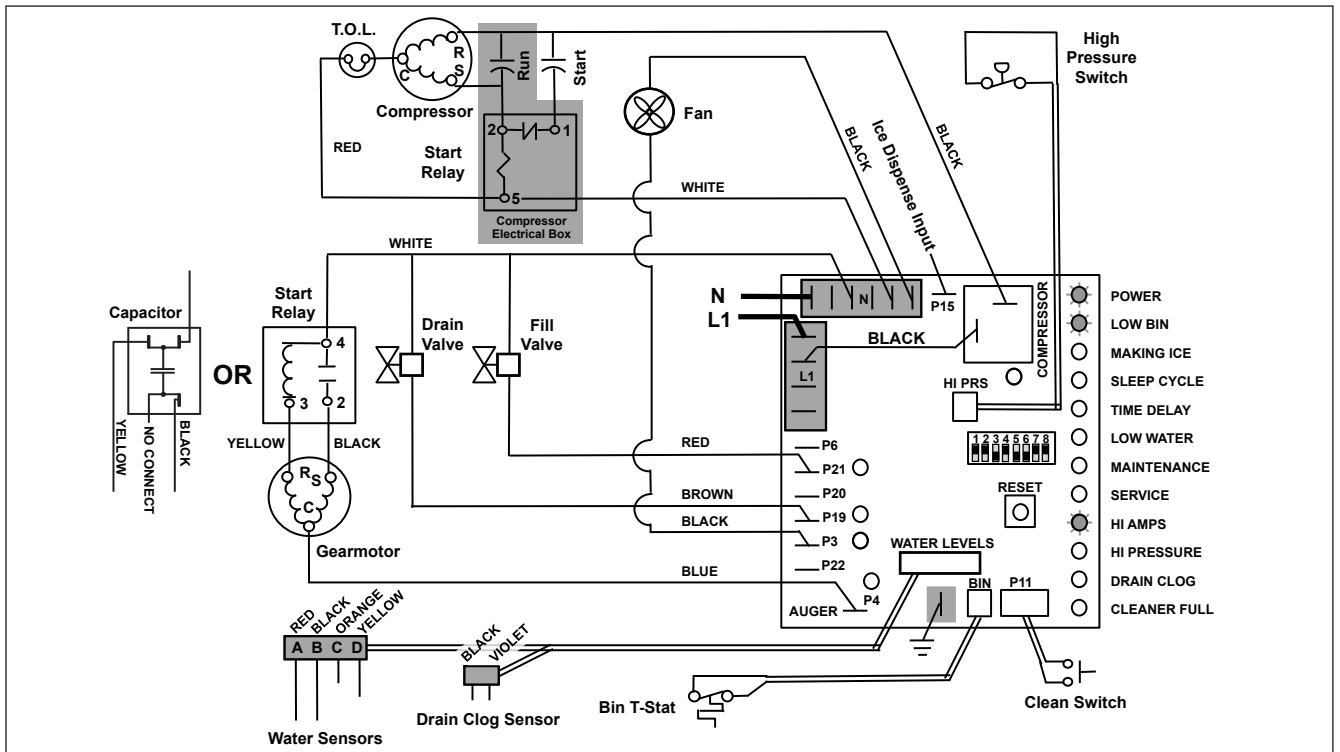

Loss of water

During operation, the water level cycles between the normal low (D) and normal high (C) water probes - the fill valve (P21) cycling on and off. If continuity is not detected between the common probe (B) and normal low (D) within 10 seconds, the **LOW WATER** and **TIME DELAY** LEDs will come on and the machine will shut down for the one hour time delay period. After the time delay, the fill valve will re-energize and wait for continuity between the common probe and normal high before restarting. **LOW WATER** LED will remain ON until the water level is satisfied.

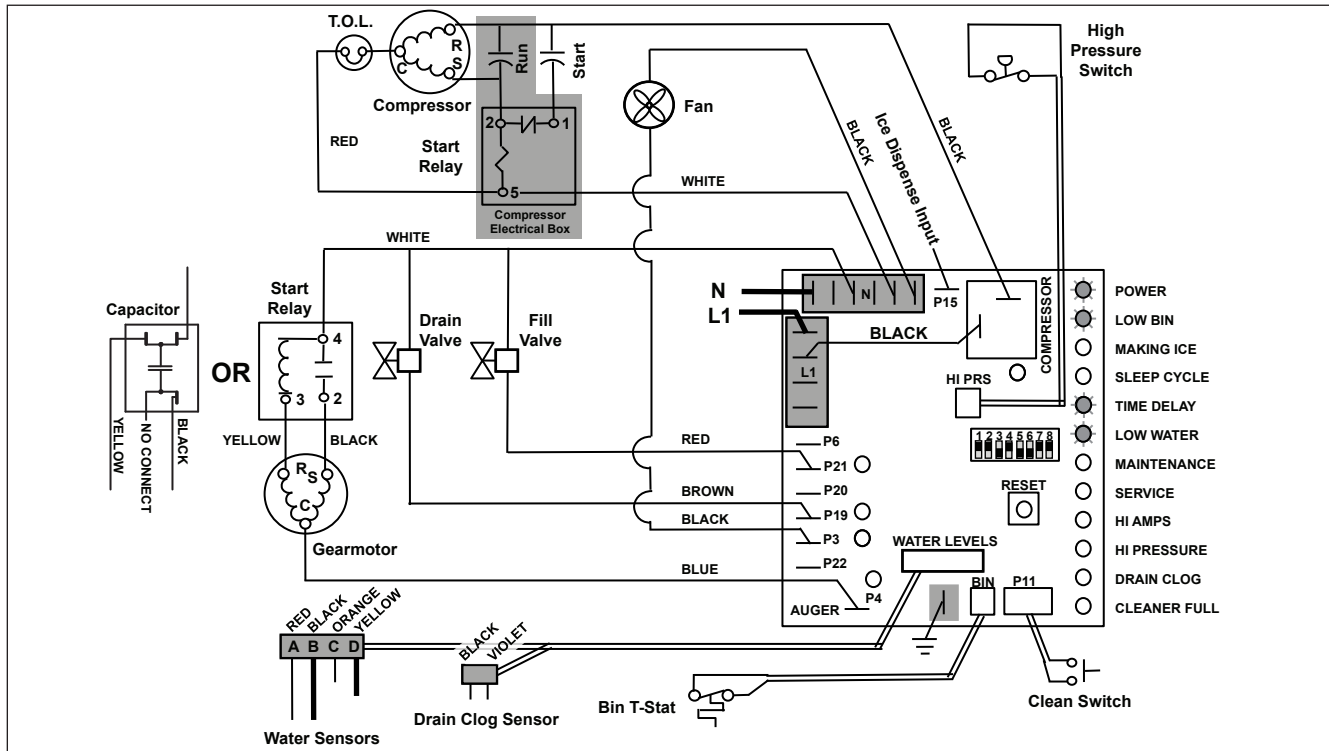

High refrigerant pressure

Should the refrigeration pressure rise above 425 psi, the high pressure switch contacts will open. The board sees the open circuit and the **HIGH PRESSURE** and **TIME DELAY** LEDs will come on, the machine shuts down. After the one hour time delay, the machine will attempt to restart. If the pressure has fallen below the reset point of 295 psi and the board see the contacts closed, the machine will resume normal operation. If the contacts are still open after the restart, the board will again go into **HIGH PRESSURE** and **TIME DELAY**, cycling until contact closure is seen.

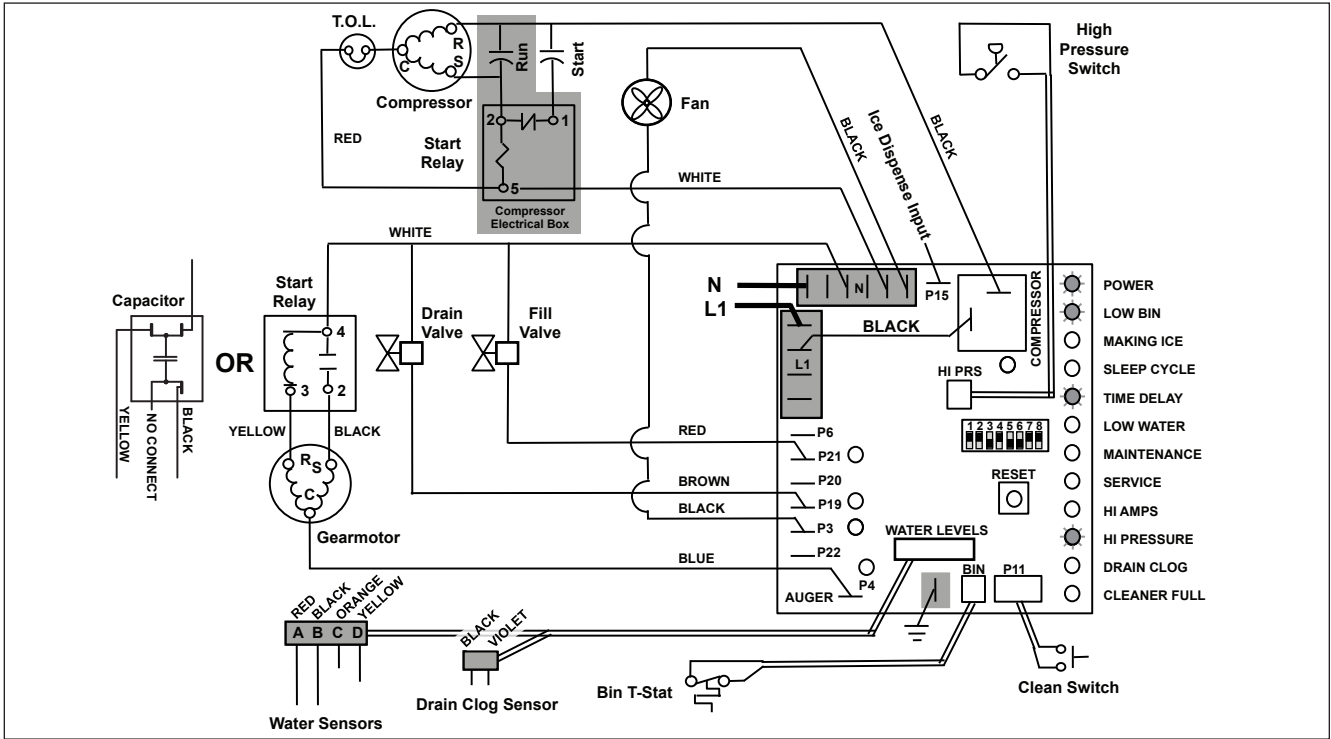

Drain clog

If continuity is seen between the two drain clog sensor probes, the **DRAIN CLOG** LED will come on and the machine will shut down. The machine will not restart unless the manual reset button is depressed while power is on.

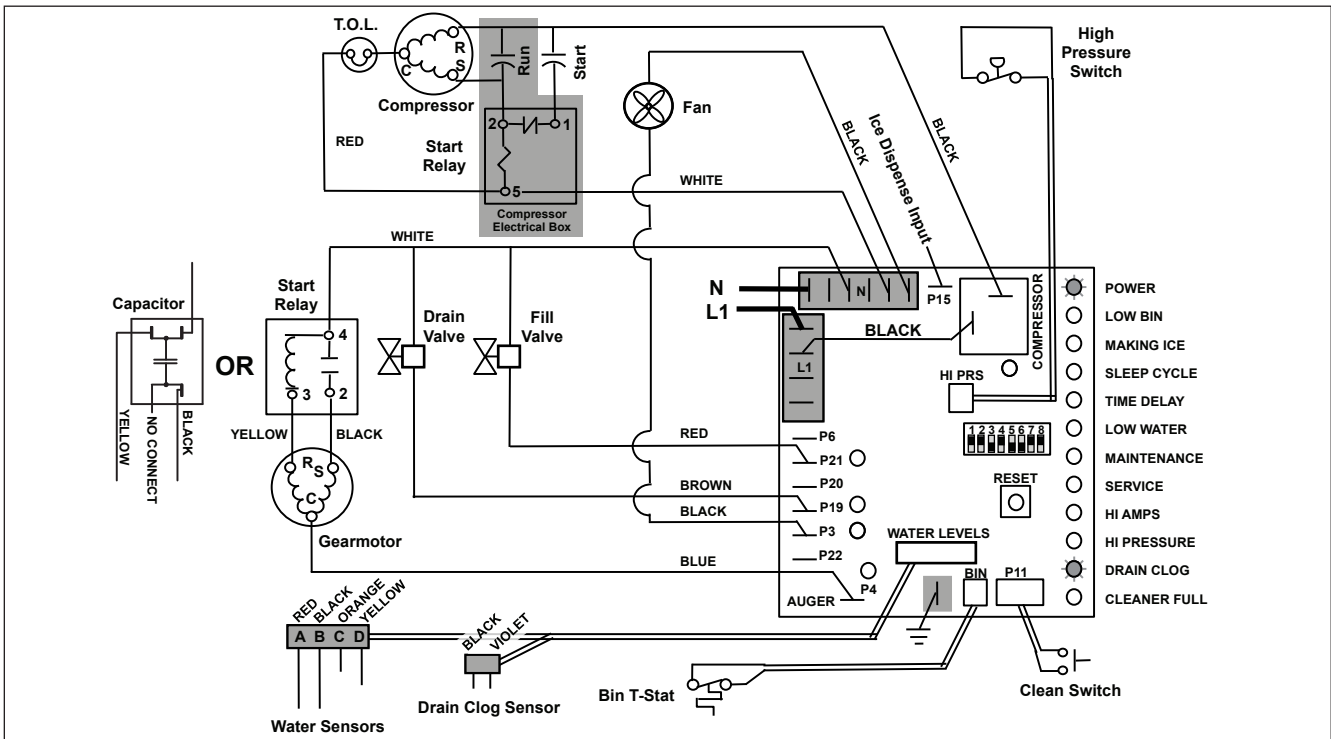

Refrigeration system (all models)

All service on refrigeration systems must be performed in accordance with all federal, state and local laws. It is the responsibility of the technician to ensure that these requirements are met. Recharging ice machine to other than factory specifications will void the warranty.

R404A ice machine charge specifications

Model	Charge	Refrigerant type
MCD425A, MFD425A, R425A, P425A (air-cooled)	15 oz. (425 g)	R404A
MCD425W, MFD425W, R425W, P425W (water-cooled)	9 oz. (255 g)	R404A

Refrigerant replacement requirements

1. Non-contaminated refrigerant removed from any Follett refrigeration system can be recycled and returned to the same system after completing repairs. Recycled refrigerant must be stored in a clean, approved storage container. If additional refrigerant is required, virgin or reclaimed refrigerant that meets ARI standard 700-88 must be used.
2. In the event of system contamination (for example, a compressor burn out, refrigerant leak, presence of non-condensibles or moisture), the system must be repaired, evacuated and recharged using virgin or reclaimed refrigerant that meets ARI standard 700-88.
3. Follett Corporation does not approve of recovered refrigerants. Improper refrigeration servicing procedures will void the factory warranty.

Evacuation

Evacuate the system to a level of 500 microns. When the 500 micron level is reached, close valves and both manifold and shut down the vacuum pump. Allow the system to sit for approximately 20 minutes. During this period the system pressure should not rise. If the system pressure rises and stabilizes there is moisture in the system and further evacuation is needed. If the pressure continues to rise check the system for leaks.

Ice capacity test

Ice machine production capacity can only be determined by weighing ice produced in a specific time period.

Replace all panels on ice machine.

1. Run ice machine for at least 15 minutes.
2. Weigh and record weight of container used to catch ice.
3. Catch ice for 15 or 20 minutes.
4. Weigh harvested ice and record total weight.
5. Subtract weight of container from total weight.
6. Convert fractions of pounds to decimal equivalents (ex. 6 lb 8 oz. = 6.5 lb).
7. Calculate production using following formula:

$$\frac{1440 \text{ min.} \times \text{wt. of ice produced}}{\text{Total test time in minutes}} = \text{Production capacity/24 hr. period}$$

8. Calculated amount per 24 hours should be checked against rated capacity for same ambient and water temperatures in Ice Production Tables.

Evaporator disassembly

Note: The upper bearing, lower bearing and auger assemblies must be replaced as assemblies. The bottom and top bearing assemblies cannot be field assembled to factory specifications.

1. Press CLEAN switch.
2. Wait for LOW WATER light to illuminate.
3. Turn OFF power.
4. Remove top bearing insulation and compression nozzle insulation.
5. Disconnect vent and drain tube from nozzle.
6. Disconnect compression nozzle from evaporator.
7. Disconnect evaporator water feed line.
8. Remove nut and upper v-band coupling from top of evaporator.
9. Lift top bearing assembly straight up with a slight rotating motion and remove.
10. Remove ice compression loop located at top of auger.
11. Lift auger straight up and out of evaporator.
12. Remove nut and lower vee band coupling from bottom of evaporator.
13. Lift evaporator to clear bottom bearing assembly.
14. Loosen hex head bolt in side of mounting base with 5/16 wrench and lift lower bearing assembly.
15. Remove condensate shield.
16. Remove 4 Allen head machine screws holding mounting base to gearbox.

Fig. 3

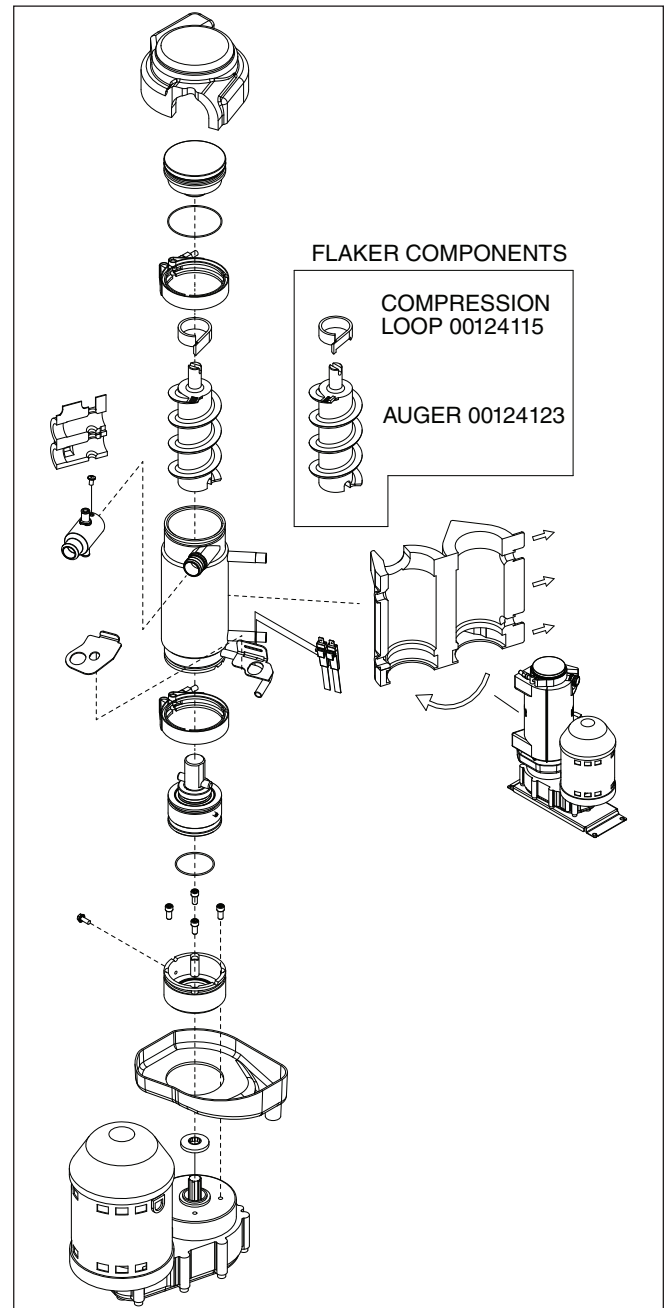

Evaporator reassembly

1. Clean gearmotor boss, output shaft and shaft well.
2. Install drain pan and evaporator mounting base.
3. Fill gear motor shaft well with food grade grease (**Fig. 4**).
4. Install condensate shield and seat against gear motor boss.
5. Install bearing O ring in groove in evaporator mounting base.

Fig. 4

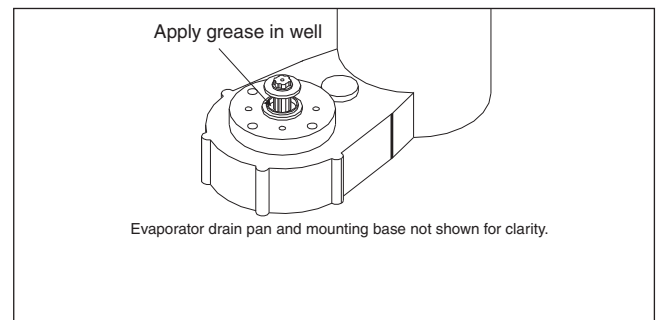

6. Lower bottom bearing assembly into evaporator mounting base.
7. *While maintaining firm downward pressure on bottom bearing assembly*, tighten hex head bolt with a 5/16 wrench.
8. Position evaporator over lower bearing assembly and align grooves with pins in bearing assembly.
9. Install vee band clamp and nut to 70 in/lb. **(Fig. 5).**

Note: Clamp **must be oriented as shown** in order for the insulation to be placed properly.

10. Place auger in center of evaporator and rotate to mate with drive pin.
11. Install ice compression loop, orienting loop.
12. Install upper bearing and seal assembly, rotating bearing to slip pin into auger slot.
13. Install upper vee band clamp and nut to 70 in/lb.
14. Install evaporator insulation.
15. Install compression nozzle and tubing.
16. Secure ice transport tube with clamp **(Fig. 6.1).**

Note: Clamp **must be oriented as shown** in order for the insulation to be placed properly.

17. Install compression nozzle insulation **(Fig. 6.2).**
18. Install vent and drain tube **(Fig. 6.3).**
19. Install top bearing insulation **(Fig. 6.4).**

Gearmotor replacement

1. Disassemble evaporator.
2. Disconnect the wire connectors.
3. Remove 4 screws holding gear motor mounting plate to base of ice machine and lift gear and motor clear of ice machine.
4. Remove machine screws holding mounting plate to motor.
5. Install new motor in reverse order.

Fig. 5

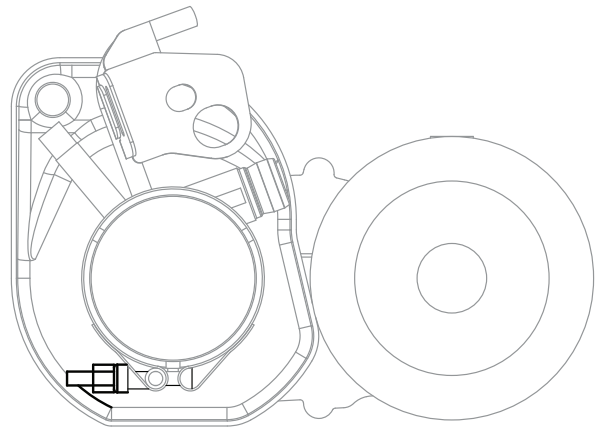
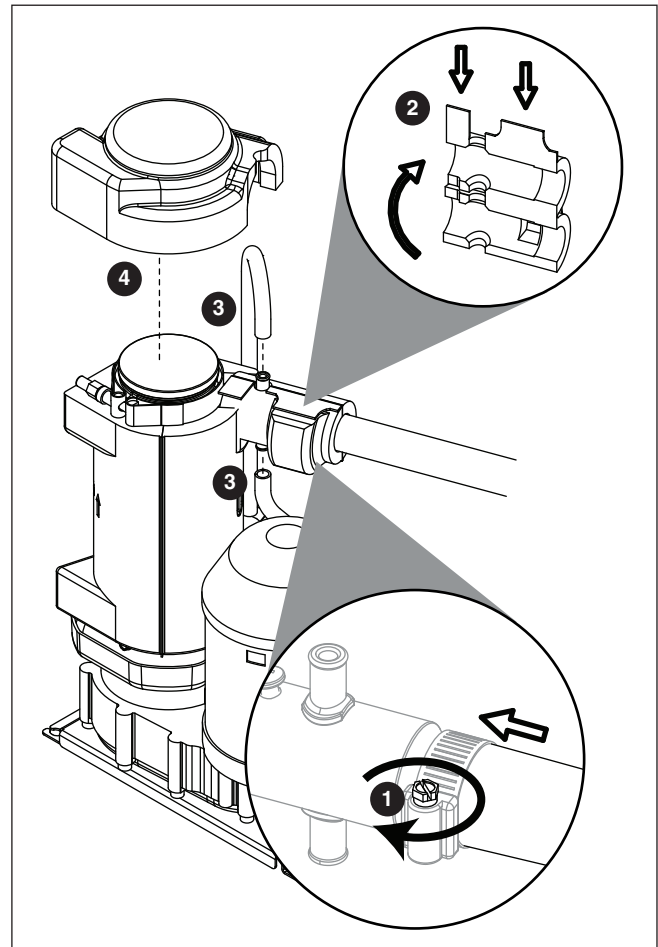

Fig. 6



Replacement parts

Replacement ice machine ordering matrix

Dispenser models	Replacement ice machine model
Dispensers with top mounted ice machines	
50CT425A & 50HT425A	P425A
50HT425W & 50HT425W	P425W
25CT 425A & 25HT425A	P425A
25CT425W & 25HT425W	P425W
110CT425A	P425A
110CT425W	P425W
Dispensers with remote ice machines	
25CR425A & 25HR425A	R425A
25CR425W & 25HR425W	R425W
50CR425A & 50HR425A	R425A
50CR425W & 50HR425W	R425W
110CR425A	R425A
110CR425W	R425W
All U150/VU155 series with air-cooled ice machines	MCD425AVS
All U150/VU155 series with water-cooled ice machines	MCD425W
All VU300 series with air-cooled ice machines	MCD425A
All VU300 series with water-cooled ice machines	MCD425W
Freestanding dispensers with ice machines in the base	
25FB425A	P425A
25FB425W	P425W
50FB425A	P425A
50FB425W	P425W
110FB425A	P425A
110FB425W	P425W
Nugget ice machine on top of bin	
MCD425ABT	MCD425ABT*
MCD425WBT	MCD425WBT*
Flake ice machine on top of bin	
MFD425ABT	MFD425ABT*
MFD425WBT	MFD425WBT*

* New bin top required.

Ice machine cleaner/descaler

00132001	SafeCLEAN environmentally-friendly cleaner, carton of 24 x 7 oz packets
----------	---

Ice machine sanitizer

00979674	Nu-Calgon IMS-II or IMS-III Sanitizer, 16 oz. bottle
00131524	Sponge, sanitary, each

Miscellaneous

Part #	Description
501860	Condensate pump
502775	Oil, gearmotor, 1 pint
501111	Grease, Mobile FM 222, 14 oz tube
500377	Clamp, ice tube
501425	Grille
01075431	Sponge, sanitary, pack of 24

Air-cooled skins assembly (MCD425A_S, R425A)

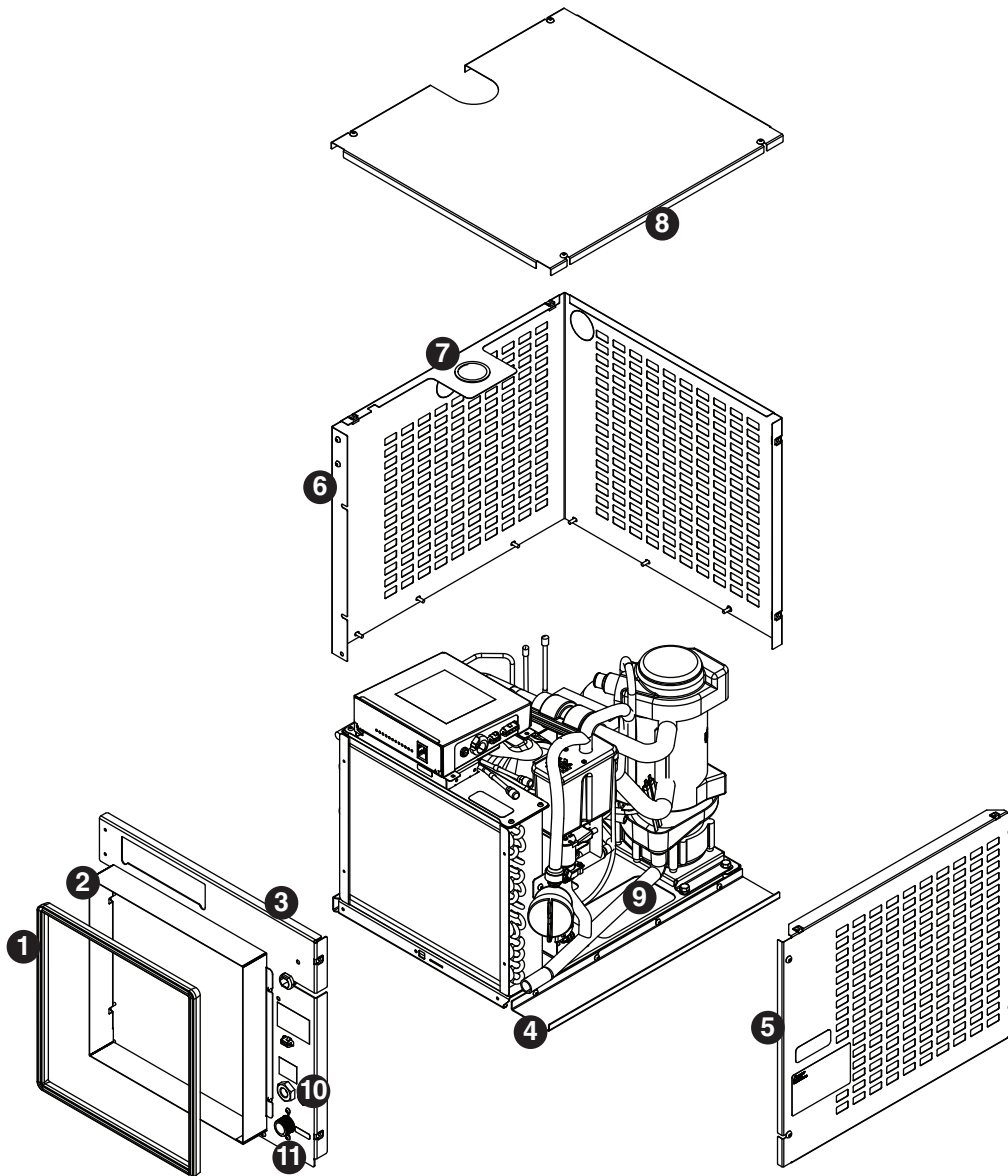

Reference #	Description	Part #
1	Gasket, duct	502781
2	Duct (including gasket)	01068188
3	Front panel	01068204
4	Spacer, base	01068220
5	Panel, right side	01068238
6	Panel, left side and rear (1 piece)	01068246
7	Bushing	01026152
8	Panel, top	01068253
9	Tube, drain	01016948
10	Fitting, water	01065375
11	Fitting, drain	00109728

Water-cooled skins assembly (MCD425W_S, R425W)

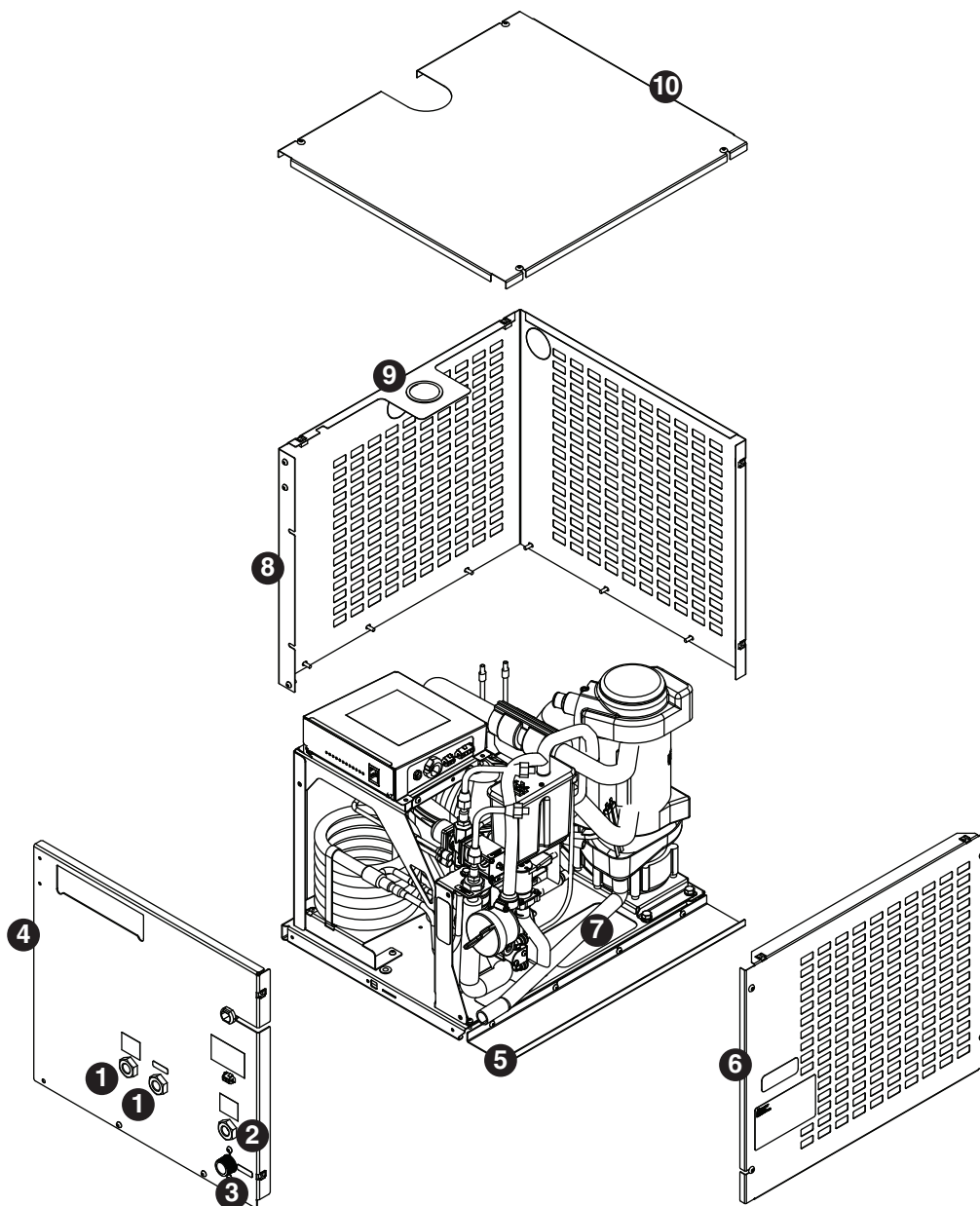

Reference #	Description	Part #
1	Fitting, condenser	00195966
2	Fitting, water	01065375
3	Fitting, drain	00109728
4	Panel, front	01068261
5	Spacer, base	01068220
6	Panel, right side	01068238
7	Tube, drain	01016948
8	Panel, left side and rear (1 piece)	01068246
9	Bushing	01026152
10	Panel, top	01068253

Louvered docking station (MCD425A/W_T)

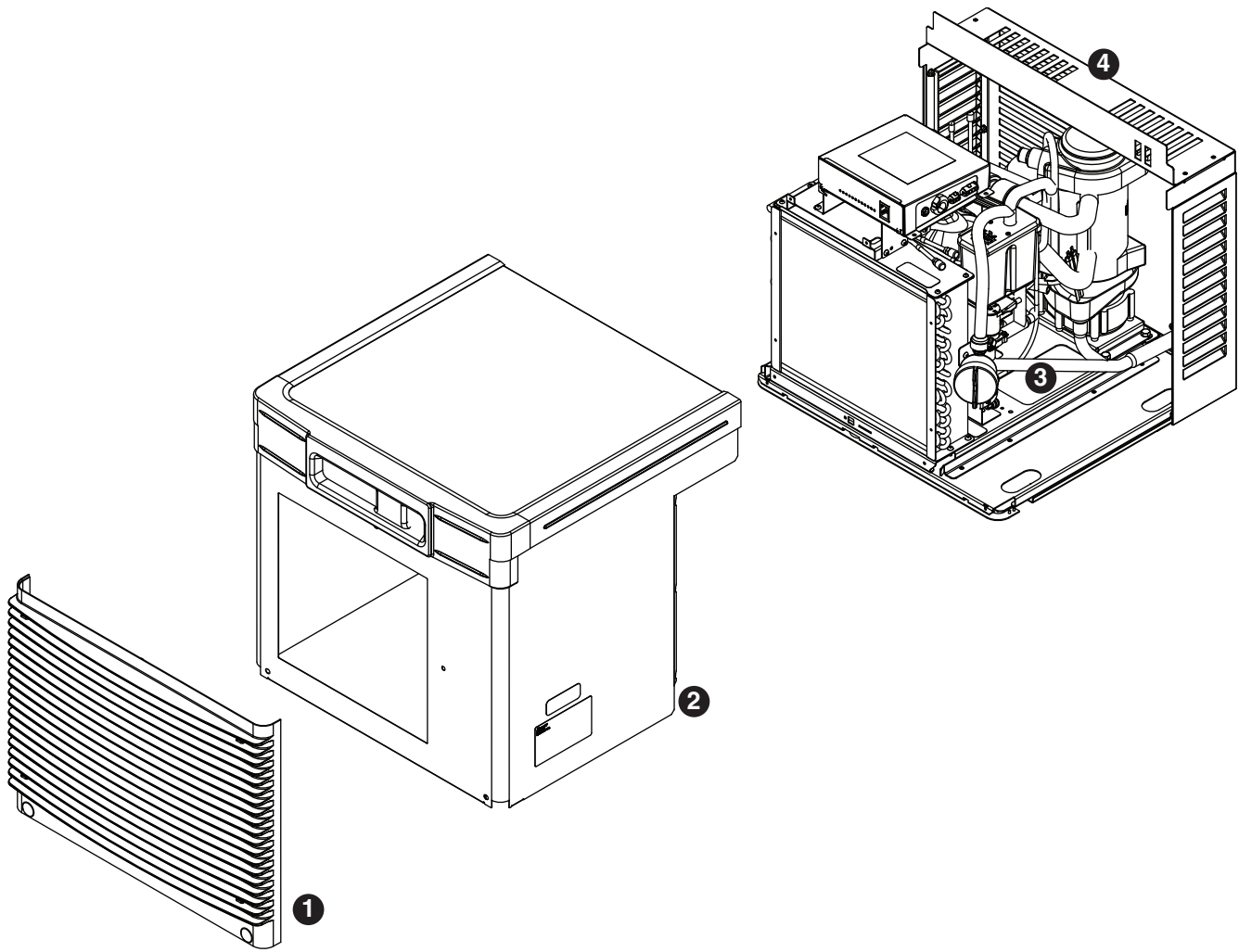

Reference #	Description	Part #
1	Louver, front	01006154
2	Cover, front	01068279
3	Tube, drain	01055185
4	Louvered docking station	01068287

Electrical components

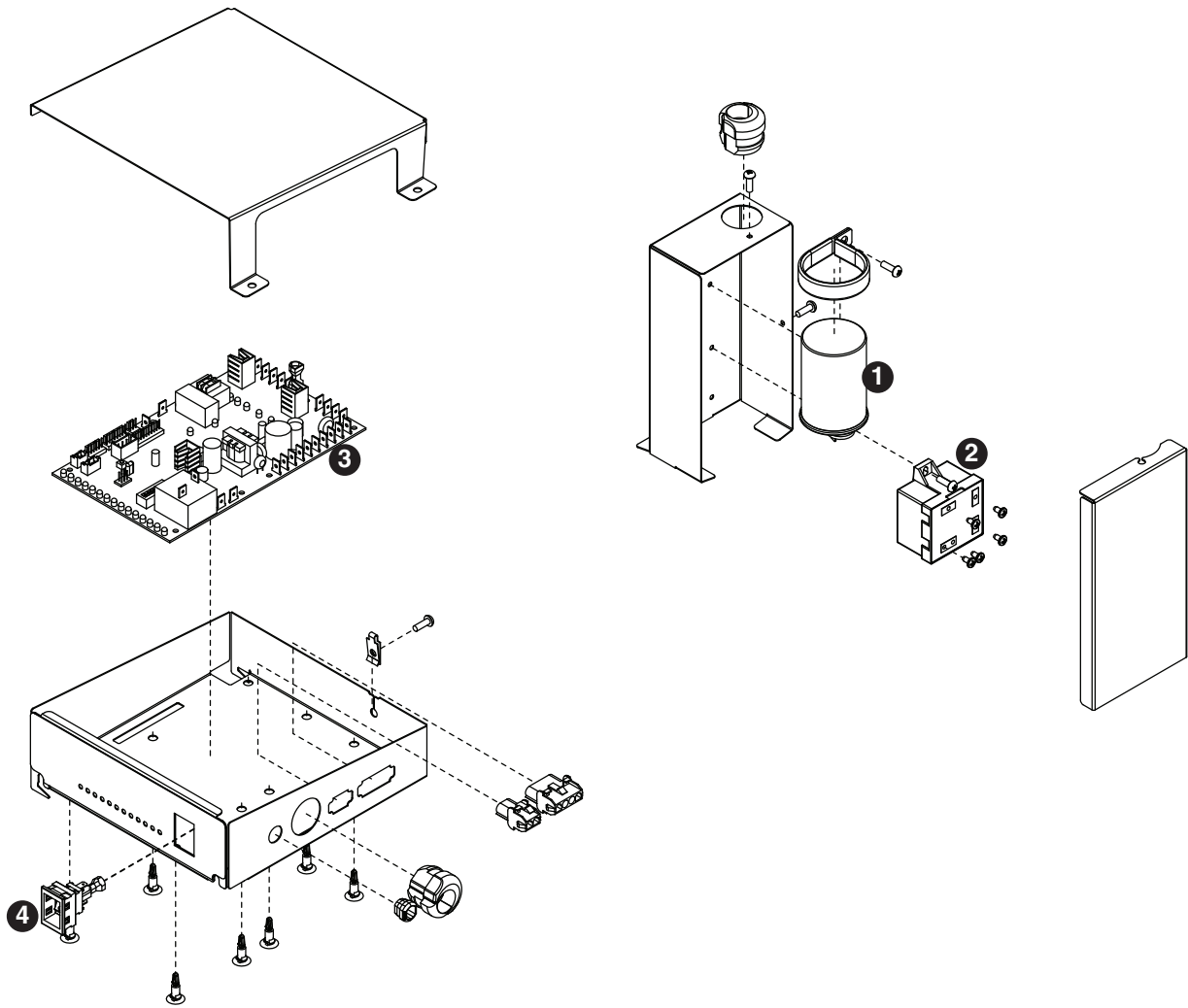

Reference #	Description	Part #
1	Capacitor, run	00997759
2	Relay start, compressor, 115 V, 60 Hz	00997726
3	Board, control circuit, 115 V, 60 Hz	01064708
4	Switch, clean	00117036
Not shown	Bin thermostat (MCD425A/WBT, MCD425A/WHT, MFD425A/WBT and MFD425A/WHT only)	500514
Not shown	Board, stand off control (8 required)	00903005
Not shown	Relay, power to contact closure	01020734
Not shown	Jumper, bin signal	01069095
Not shown	Cord and plug, power	01075589
Not shown	Converter, bin signal, Vision	01067156
Not shown	Relay, bin signal (power to contact closure)	01020734

Evaporator

FOOD SERVICE

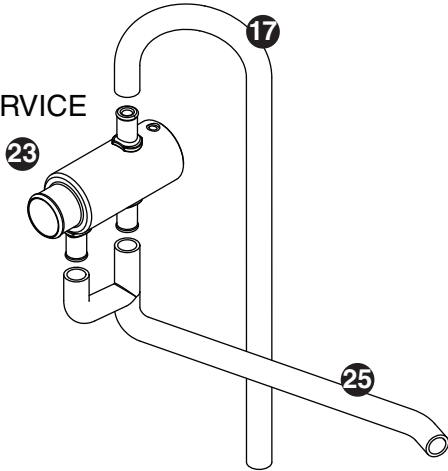

HEALTHCARE

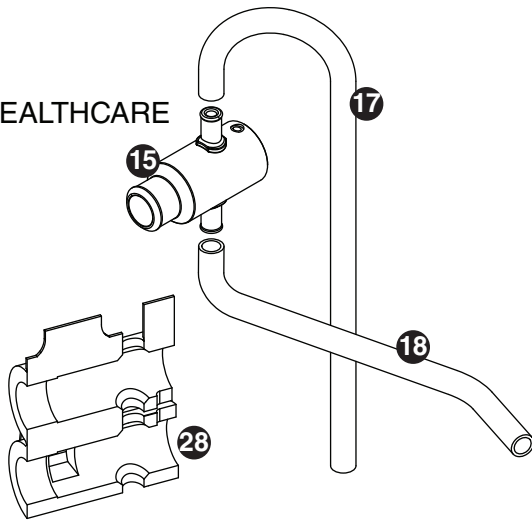

FLAKER

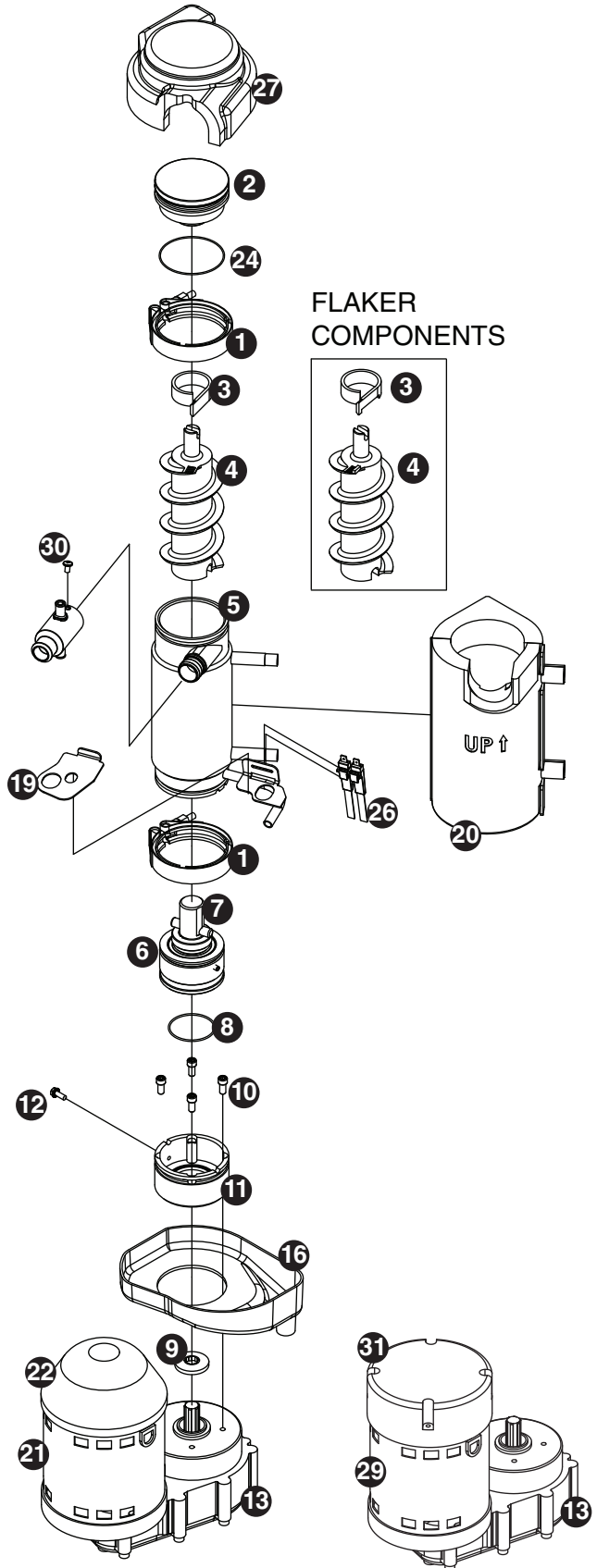
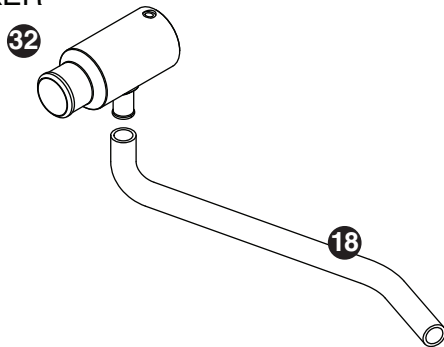

Evaporator

Reference #	Description	Part #
1	Coupling, vee band, includes nut	502735
2	Bearing assembly, top	502736
3	Loop, ice compression, beveled (see below for Flaker-specific components)	502110
4	Auger (see below for Flaker-specific components)	502737
5	Evaporator (includes insulation jacket, 502740)	01064658
6	O ring, bearing housing	500496
7	Bearing assembly, bottom (includes O rings and condensate shield)	502738
8	O ring, mounting base	501063
9	Shield, condensate	500744
10	Screw, Allen 1/4 20 x 1/2 (set of 4)	501080
11	Mounting base, evap. (includes 501063)	502733
12	Bolt, mounting base	502227
13	Gearbox and motor	502730
Not shown	Mounting base, gearbox	01067693
15	Compression nozzle, with single drain	01064674
16	Drain pan, evaporator	00181990
17	Tube, compression nozzle vent	01027804
18	Tube, compression nozzle, single drain	01027416
Not shown	Grease, Chevron SRI-2, 14 oz	501111
19	Bracket, vent hoses	01007087
20	Insulation jacket, evaporator	01049592
21	Relay, gearmotor (for split-phase motor only)	00142042
22	Cover, black plastic	01012228
23	Nozzle, compression, dual drain	01067446
24	O ring, top bearing	01064963
25	Tube, compression nozzle, dual drain	01033778
26	Sensor, overflow	01039783
27	Insulation, top bearing	01049600
28	Insulation, compression nozzle, single drain	01049584
29	16 μ F Capacitor (for PSC motor only)	01103142
30	Screw, compression nozzle	00956250
31	Cover, aluminum	01106376
Not shown	O-ring, compression nozzle	00988097

Flaker-specific components

Reference #	Description	Part #
3	Loop, compression, notched	00124115
4	Auger (with paddle)	00124123
18	Tube, compression nozzle, single drain	01027416
32	Compression nozzle, flaker	01067453

Air-cooled ice machines

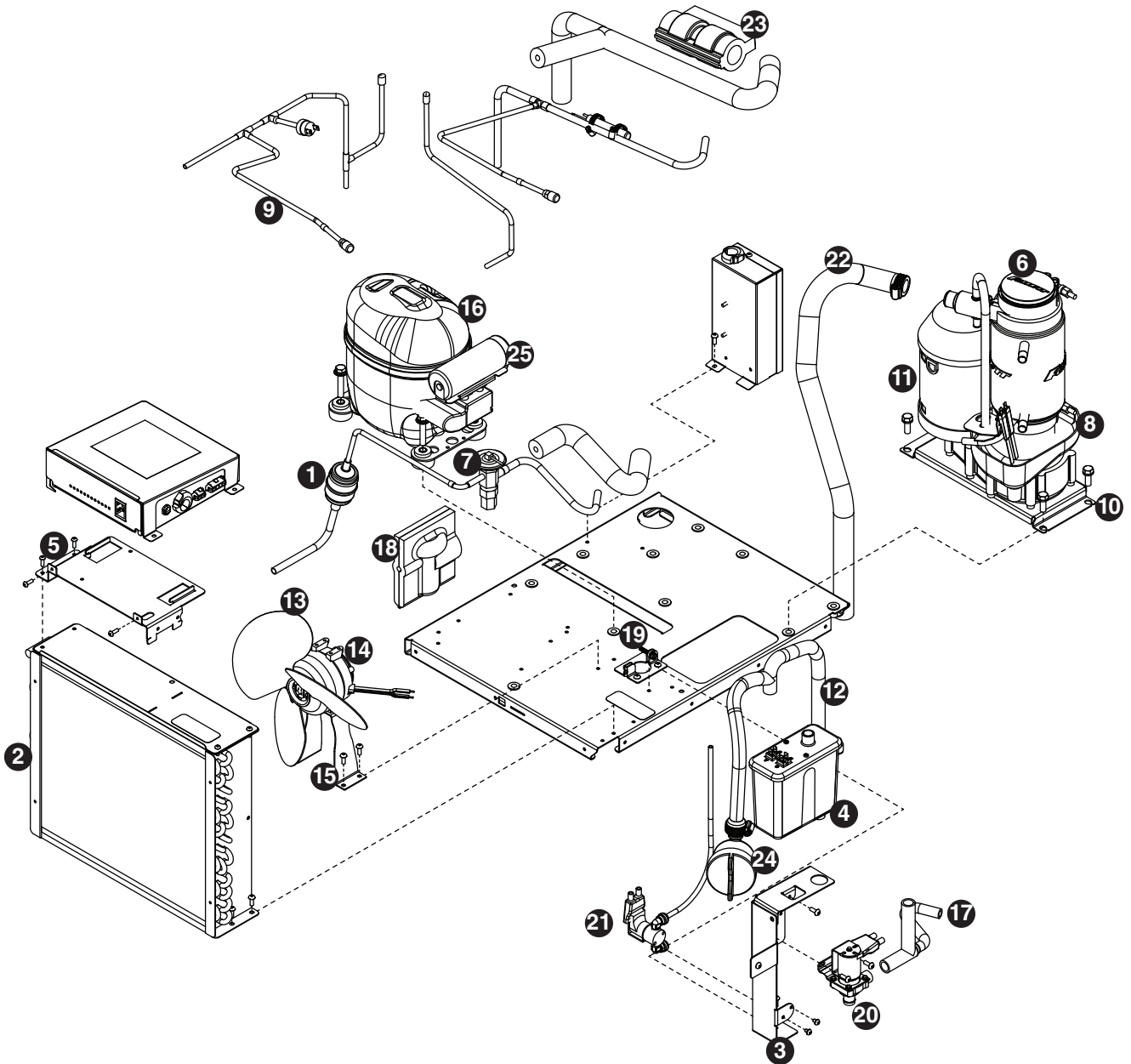

Air-cooled ice machines

Reference #	Description	Part #
1	Drier	502724
2	Condenser coil, A/C	01067461
3	Reservoir mounting bracket, a/c	01072909
4	Reservoir assembly	01064682
5	Bracket, electrical box	01068170
6	Evaporator (see page 32 and 33 for complete breakdown)	—
Not shown	Tubing, polypropylene, reservoir supply (sold by foot)	502079
7	Valve, expansion, thermal	502726
8	Drain pan, evaporator	0018190
9	High pressure cutout	00117077
10	Mounting bracket, gearbox	01067693
11	Gearbox & motor assembly, 115 V, 60 Hz	502730
12	Tubing, clean and vent	00998765
13	Fan blade	500474
14	Motor, fan, 115 V, 60 Hz	500672
15	Bracket, fan motor	01067107
Not shown	Overload, compressor, 115 V, 60 Hz	01027572
16	Compressor, 115 V, 60 Hz	01065259
17	Tube, fill/purge - reservoir-solenoid-evaporator feed	01051192
Not shown	Water inlet fitting, brass	01065275
Not shown	Fitting, reservoir, plastic 1/4" stem x 1/4" push-in	00121699
18	Jacket, insulation, TXV	502830
19	Bracket, ice tube entry	01067644
20	Solenoid, purge	01146257
21	Solenoid, fill	01082403
Not shown	Tube, drain, MCD425AxT, 25/50FB	01055185
Not shown	Tube, drain, MCD425AxT, 110FB, 110CT	01055540
Not shown	Tube, drain, MCD425AxS	01016948
22	Tube, ice transport, MCD425A/WxT	01003532
23	Jacket, insulation, TXV bulb	00106534
24	Cup, cleaning	01065226
Not shown	Gasket, reservoir	00990978
25	Capacitor, start	01026145

Water-cooled ice machines

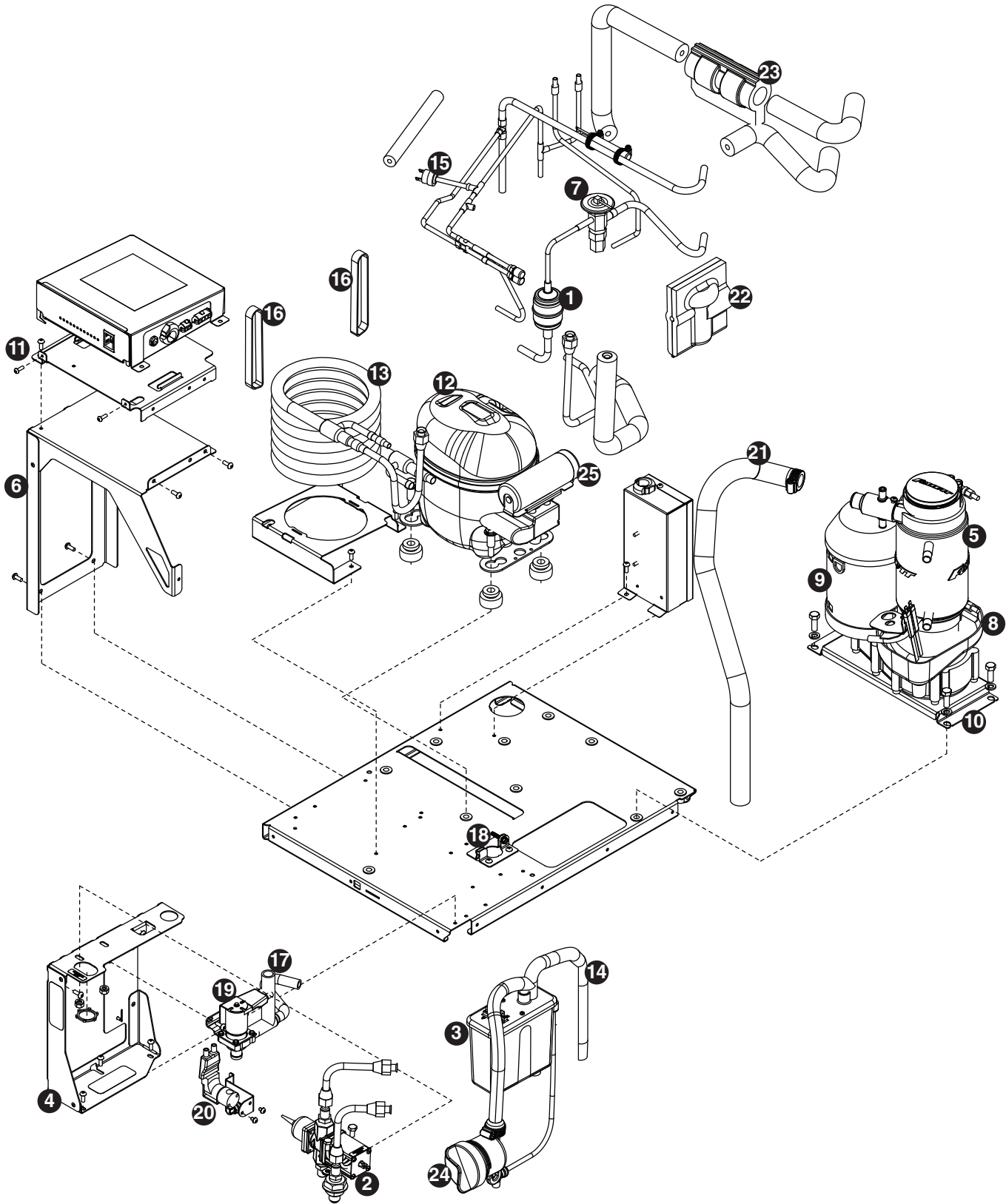

Water-cooled ice machines

Reference #	Description	Part #
1	Drier	502724
2	Valve, water regulating (includes Iso-washer)	500537
Not shown	Iso-washer (for water regulating valve)	501810
3	Reservoir assembly	01064682
4	Reservoir mounting bracket	01068162
Not shown	Tubing, polypropylene, reservoir supply (sold by foot)	502079
Not shown	Fitting, reservoir, plastic 1/4" stem x 1/4" push-in	00121699
5	Evaporator (see page 32 and 33 for complete breakdown)	—
6	Bracket, electrical box tower	01068121
7	Valve, expansion, thermal	502726
8	Drain pan, evaporator	00181990
9	Gearbox & motor assembly, 115 V, 60 Hz	502730
10	Mounting bracket, gearbox	01067693
11	Bracket, electrical box mounting	01068139
Not shown	Overload compressor, 115 V, 60 Hz	01027572
12	Compressor, 115 V, 60 Hz	01065259
13	Coil, condenser	00195933
14	Tube, clean and vent	00998765
Not shown	Water inlet fitting, brass	01065275
15	High pressure cutout	00117077
16	Ty-rap (2 required)	204584
17	Tube, fill/purge - reservoir-solenoid-evaporator feed	01051192
18	Bracket, ice tube entry	01067644
19	Solenoid, purge	01146257
20	Solenoid, fill	01082403
Not shown	Tube, drain, 25/50CI	01054576
Not shown	Tube, drain, MCD425AxT, 25/50FB	01055185
Not shown	Tube, drain, MCD425AxT, 110FB, 110CT	01055540
Not shown	Tube, drain, MCD425AxS	01016948
21	Tube, ice transport, MCD425A/WxT	01003532
22	Jacket, insulation, TXV	502830
23	Jacket, insulation, TXV bulb	00106534
24	Cup, cleaning	01065226
Not shown	Bracket, fill solenoid	01072867
Not shown	Gasket, reservoir	00990978
25	Capacitor, start	01026145

Water treatment accessories for Symphony ice and water dispensers

Reference #	Description	Part #
Standard capacity filter system		
Not shown	Follett QC4-FL4S water filter system (includes FL4S primary cartridge and head, coarse pre-filter and head, pressure gauge, flushing valve; assembled and installed on mounting bracket), one per ice machine	00130229
Not shown	Follett FL4S primary replacement cartridge	00130245
Not shown	Water filter cartridge – primary, carton of 6	00954297
Not shown	Everpure coarse pre-filter cartridge	00130211
Not shown	Water pre-filter cartridge – pre-filter, carton of 12	00954305
High capacity filter system		
Not shown	High capacity water filter system (one per ice machine)	00978957
Not shown	High capacity water filter cartridge – primary, single	00978965
Not shown	High capacity water filter cartridge – primary, carton of 6	00978973
Not shown	Water pre-filter cartridge – pre-filter, single	00130211
Not shown	Water pre-filter cartridge – pre-filter, carton of 12	00954305
Carbonless high capacity filter system		
Not shown	Carbonless high capacity water filter system (one per ice machine) – Horizon™ and MaestroPlus series ice machines	01050442
Not shown	Carbonless high capacity water filter cartridge – primary, single	01050426
Not shown	Carbonless high capacity water filter cartridge – primary, carton of 6	01050434
Not shown	Water pre-filter cartridge – pre-filter, single	00130211
Not shown	Water pre-filter cartridge – pre-filter, carton of 12	00954305
Other filtration		
Not shown	Claris hardness removal filtration system	00986059
Not shown	Replacement filter for Claris system	00985127
Not shown	Reverse osmosis system, 200 gallons per day	00986034
Not shown	Replacement reverse osmosis cartridge	00985085
Not shown	Replacement reverse osmosis pre-filter	00985077
Not shown	Cleaning plug for reverse osmosis system	00985119
Not shown	Cleaning cartridge for reverse osmosis system	00985101
Water pressure		
Not shown	Water pressure regulator (25 psi)	501781

Miscellaneous

Reference #	Description	Part #
Not shown	Diverter plate (single agitator Cornelius dispensers and left-hand dispense chute on dual-agitator Cornelius dispensers)	307277
Not shown	Diverter plate (right-hand dispense chute on dual-agitator dispensers)	00996207
Not shown	Diverter plate, Cornelius Flavor Fusion	01100825

Rejestracja gwarancji i ocena sprzętu

Dziękujemy za zakup urządzenia firmy Follett. Mamy nadzieję, że nasze urządzenia spełniają i przekraczają Państwa oczekiwania, gdyż naszym celem jest dostarczenie klientom wysoce wartościowych produktów i usług, zasługujących na ich pełne uznanie.

Prosimy zapoznać się z załączoną instrukcją instalacji i obsługi. Istotne jest przeprowadzenie instalacji zgodnie z wymogami producenta, co zapewni działanie urządzenia z maksymalną wydajnością.

Follett LLC nie będzie ponosić odpowiedzialności za szkody wtórne, wydatki, koszty podłączania lub odłączania lub jakiegokolwiek straty wynikające z wady urządzenia.

Aby uzyskać szczegółowe informacje na temat warunków gwarancji, prosimy odwiedzić naszą stronę internetową www.follettice.com/productwarranties.

Rejestracja gwarancji i ocena urządzenia to istotne czynności, ułatwiające nam utrzymanie aktualnych danych o miejscach instalacji naszych urządzeń i o ich działaniu. Prosimy o zarejestrowanie gwarancji na nabyte urządzenie firmy Follett na naszej witrynie www.follettice.com/support, gdzie należy wybrać Warranty Registration (Rejestracja gwarancji) i Equipment Evaluation (Ocena urządzenia). Jest to łatwe i nieskomplikowane, prosimy o znalezienie na to paru minut jeszcze dzisiaj. Na formularzu jest również miejsce na przekazanie nam komentarzy i informacji zwrotnych. Proszę podzielić się z nami swoimi wrażeniami, abyśmy mogli wykorzystywać je w naszych ciągłych dążeniach do usprawnień.

Jesteśmy dumni z naszych znakomitych urządzeń i staramy się usilnie wspierać je znakomitą obsługą klienta i wsparciem technicznym. Chcielibyśmy wiedzieć, w jaki jeszcze sposób moglibyśmy Państwu pomóc. Z przyjemnością odpowiemy na Państwa pytania.

Registro de Garantía y Evaluación del Equipo

Gracias por haber elegido este producto Follett®. Esperamos que nuestro equipo cumpla o supere sus expectativas porque es nuestro objetivo ofrecer productos y servicios de gran valor que se ganen su plena confianza.

Le rogamos consulte el manual de instalación y de instrucciones adjunto, ya que es muy importante que la instalación se realice según las especificaciones de fábrica para que el equipo funcione a su máxima eficiencia.

Follett LLC no se hace responsable de los daños indirectos, costos, gastos por conexión y desconexión o pérdidas por causa de defecto de la máquina.

Si desea una información más completa sobre la garantía, visite nuestro sitio web www.follettice.com/productwarranties.

Las operaciones de registro de la garantía y evaluación del equipo son importantes para que podamos realizar un seguimiento de nuestro equipo y registrar el rendimiento de la maquinaria. Por favor, registre las garantías del equipo Follett en nuestro sitio web www.follettice.com/support y seleccione Registro de la Garantía y Evaluación del Equipo. Es muy sencillo, solo le llevará un momento realizar hoy mismo el registro. En el formulario incluimos un espacio en blanco para sus comentarios y opiniones. Infórmenos sobre su experiencia para que podamos incorporarla a nuestros continuos esfuerzos de mejora.

Nos enorgullecemos de producir un equipo excepcional y trabajamos duro para respaldarlo con un soporte técnico y un servicio de atención al cliente de primera. Le rogamos nos indique qué más podemos hacer para ayudarlo. Estaremos encantados de responder a sus dudas.

Enregistrement de la garantie et évaluation de l'équipement

Merci d'avoir acheté un équipement Follett®. Notre objectif étant d'offrir des produits et des services de grande valeur vous satisfaisant pleinement, nous espérons que celui-ci satisfera, voire dépassera, vos attentes !

Veuillez consulter le manuel d'installation et d'exploitation. Il est important que l'installation soit réalisée conformément aux spécifications de l'usine, de sorte que votre équipement fonctionne à son rendement maximum.

Follett LLC n'est pas responsable de tout dommage consécutif, de toute dépense, de tout frais de raccordement ou de déconnexion, ni de toute perte liée à un défaut de la machine.

Pour lire la garantie dans son ensemble, visitez notre site Internet www.follettice.com/productwarranties.

L'enregistrement de la garantie et l'évaluation de l'équipement sont importants pour nous aider à suivre notre équipement et pour enregistrer les performances de la machine. Nous vous demandons donc d'enregistrer la garantie de votre équipement Follett sur notre site Internet, www.follettice.com/support, dans la section Warranty Registration and Equipment Evaluation. Cette opération est simple ; veuillez prendre un moment pour la réaliser aujourd'hui.

Le formulaire contient également un espace pour nous faire parvenir vos commentaires et un retour d'informations. Veuillez nous faire part de votre expérience pour que nous puissions prendre appui dessus pour poursuivre nos efforts constants d'amélioration.

Nous sommes fiers de produire des équipements exceptionnels et nous travaillons avec acharnement pour y associer une assistance à la clientèle et technique exceptionnelle. N'hésitez pas à nous indiquer dans quelle mesure nous pouvons vous aider. Nous serions ravis de répondre à vos questions.

Garantieregistrierung und Produktbeurteilung

Vielen Dank, dass Sie sich für ein Follett®-Produkt entschieden haben. Wir hoffen, dass unser Produkt Ihre Erwartungen erfüllen oder sogar übertreffen wird, weil wir uns zum Ziel gesetzt haben, hochwertige Produkte und Leistungen anzubieten, die Ihre uneingeschränkte Anerkennung verdienen werden!

Lesen Sie sich bitte die beiliegende Installations- und Betriebsanleitung durch. Es ist wichtig, dass die Installation entsprechend den Werksangaben erfolgt, damit Ihr Produkt mit maximalem Wirkungsgrad arbeiten kann.

Follett LLC ist nicht für Folgeschäden, Ausgaben, Gebühren für Anschluss oder Abschaltung oder Verluste aufgrund eines Defekts der Maschine haftbar.

Vollständige Garantieinformationen finden Sie auf unserer Website unter www.follettice.com/productwarranties.

Garantieregistrering und Produktbeurteilung sind wichtig, damit wir einen Überblick über unsere Produkte behalten und ihre Effizienz bewerten können. Wir möchten Sie bitten, Garantien für Follett-Produkte auf unserer Website www.follettice.com/support zu registrieren und den Punkt „Garantieregistrering und Produktbeurteilung“ zu wählen. Es ist ganz einfach. Nehmen Sie sich bitte einen Moment Zeit, um die Registrierung heute vorzunehmen. Auf dem Formular ist auch Platz für Kommentare und Feedback vorhanden. Teilen Sie uns bitte Ihre Erfahrungen mit unseren Produkten mit, damit wir sie für unsere fortlaufenden Produktverbesserungen verwenden können.

Wir sind stolz darauf, dass wir besondere Produkte herstellen, und wir bemühen uns, unsere Produkte mit besonderem Kundendienst zu unterstützen. Lassen Sie uns bitte wissen, was wir noch für Sie tun können. Wir werden Ihre Fragen gerne beantworten.

Registrazione della garanzia e valutazione dell'attrezzatura

Grazie per aver acquistato un dispositivo Follett®. Ci auguriamo che il nostro prodotto soddisfi o superi le Sue aspettative, in quanto il nostro obiettivo è quello di offrire prodotti e servizi di alta qualità che soddisfino pienamente le vostre esigenze!

La preghiamo di leggere attentamente il manuale per l'installazione e per l'uso allegato. È infatti importante che l'installazione sia effettuata secondo le specifiche di fabbrica in modo tale che il dispositivo operi con la massima efficienza.

La Follett LLC non si assume alcuna responsabilità per danni conseguenti, spese, costi di collegamento o scollegamento o eventuali perdite dovute ad un difetto della macchina.

Per visualizzare i dettagli completi relativi alla garanzia, recarsi alla pagina www.follettice.com/productwarranties.

La registrazione della garanzia e la valutazione dell'attrezzatura sono importanti per aiutarci a tenere traccia dei nostri dispositivi e a registrare le prestazioni della macchina. Le chiediamo dunque di registrare le garanzie relative al dispositivo Follett sul nostro sito Web alla pagina www.follettice.com/support scegliendo Registrazione della garanzia e Valutazione dell'attrezzatura. Farlo è semplice; dedichi pochi minuti a registrare il prodotto oggi stesso. Sul modulo è inoltre previsto uno spazio in cui potrà fornirci i Suoi commenti e il Suo riscontro. Ci faccia sapere della Sua esperienza in modo che possiamo farne tesoro per il nostro continuo miglioramento.

Siamo orgogliosi di produrre macchinari di ottima qualità e lavoriamo sodo per offrire un servizio di assistenza clienti e tecnico di qualità altrettanto elevata. Ci faccia sapere come possiamo esserle di aiuto. Saremo lieti di rispondere a tutte le Sue domande.

Registo da garantia e avaliação do equipamento

Obrigado por ter adquirido equipamento Follett®. Fazemos votos de que o nosso equipamento cumpra ou exceda as suas expectativas, dado que temos por objetivo fornecer produtos e serviços de elevado valor que mereçam a sua total satisfação!

Pedimos-lhe que leia o manual de instalação e operações em anexo. É importante que a instalação seja levada a cabo de acordo com as especificações da fábrica, para que o seu equipamento funcione com a eficiência máxima.

A Follett LLC não assume a responsabilidade por quaisquer prejuízos indiretos, despesas, custos de ligação ou desligação ou quaisquer outras perdas decorrentes de um defeito na máquina.

Para consultar os dados da garantia, visite o nosso website www.follettice.com/productwarranties.

O registo da garantia e a avaliação do equipamento são importantes para nos ajudar a estar a par do nosso equipamento e registar o desempenho da máquina. Pedimos-lhe que registe as garantias de equipamento Follett no nosso website www.follettice.com/support, em “Warranty Registration and Equipment Evaluation”. É muito simples; tire uns minutos para fazer o registo hoje mesmo. O formulário inclui também espaço para os seus comentários e feedback. Conte-nos a sua experiência para que possamos usá-la nos nossos esforços contínuos de melhoria.

Temos muito orgulho em produzir equipamento excepcional e empenhamo-nos em proporcionar um apoio técnico e um apoio ao cliente igualmente excecionais. Diga-nos o que mais podemos fazer para o ajudar. Teremos todo o prazer em responder às suas perguntas.

Registrering af garanti og evaluering af udstyr

Tak for dit køb af Follett®-udstyr. Forhåbentlig synes du, at vores udstyr lever op til eller overstiger dine forventninger, for vores målsætning er at levere produkter og serviceydelser af høj kvalitet, som du er fuldstændig tilfreds med!

Gennemlæs venligst den vedlagte installations- og driftsmanual. Det er vigtigt at installationen udføres i henhold til fabriksspecifikationerne, så dit udstyr kan fungere med maksimal effektivitet.

Follett LLC hæfter ikke for følgeskader, udgifter, tilslutnings- eller frakoblingsomkostninger eller nogen form for tab, der skyldes en maskindefekt.

Du kan læse de fulde oplysninger om garantien på vores website www.follettice.com/productwarranties.

Registrering af garantien og evaluering af udstyret er vigtigt for at hjælpe os med at følge op på vores udstyr og registrere maskinens ydelse. Vi beder dig registrere garantier på Follett-udstyr på vores website www.follettice.com/support og vælge Warranty Registration and Equipment Evaluation (Registrering af garanti og evaluering af udstyr). Det er nemt at gøre, så vi beder dig bruge et øjeblik på at registrere dig i dag. Formularen har også plads til, at du kan give os kommentarer og feedback. Fortæl os om dine erfaringer, så vi kan bruge dem i vores fortsatte bestræbelser på at forbedre os.

Vi sætter en ære i at fremstille udstyr i særklasse og arbejder hårdt på at kunne bakke udstyret op med fremragende kundeservice og teknisk support. Fortæl os, hvad vi ellers kan gøre for at hjælpe dig. Vi svarer gerne på dine spørgsmål.

Registratie van garanties en beoordeling van apparatuur

Gefeliciteerd met uw aankoop van Follett®-apparatuur. We hopen dat onze apparatuur uw verwachtingen invult of zelfs overstijgt, omdat we ernaar streven om hoogwaardige producten en diensten te leveren die u uitermate tevreden stellen!

Lees de bijgevoegde installatie- en bedieningshandleiding zorgvuldig door. Het is belangrijk dat de installatie uitgevoerd wordt volgens de fabrieksspecificaties, zodat uw apparatuur zo efficiënt mogelijk werkt.

Follett LLC is niet aansprakelijk voor enige gevolgschade, uitgaven, montage- of demontagekosten of enige door een defect van de machine geleden verliezen.

Bezoek onze website www.follettice.com/productwarranties voor alle garantiegegevens.

De registratie van garanties en de beoordeling van apparatuur is belangrijk voor ons om onze apparatuur te helpen traceren en de prestaties van de machine te registreren. We verzoeken u dan ook om garanties van Follett-uitrusting te registreren op onze website www.follettice.com/support en om "Warranty Registration" (Registratie van garanties) en "Equipment Evaluation" (Beoordeling van apparatuur) te kiezen. Gelieve hier even tijd voor vrij te maken. Het is namelijk zeer eenvoudig. Er is op het formulier ook plaats om opmerkingen en feedback te geven. Breng ons gerust op de hoogte over uw ervaring met onze apparatuur, zodat we ons kunnen blijven verbeteren.

We zijn trots op onze productie van uitstekende apparatuur en werken hard om dit bij te staan door een voortreffelijke klantendienst en technische ondersteuning. Aarzel echter niet om enige andere bijstand te vragen. We zullen uw vragen met plezier beantwoorden.

Garantiregistrering och utvärdering av utrustning

Tack för att du köpt utrustning från Follett®. Vi hoppas att du ska tycka att den uppfyller eller överträffar dina förväntningar, då vårt mål är att leverera produkter och tjänster av högt värde som gör dig helt nöjd!

Studera medföljande installations- och bruksanvisning. Det är viktigt att installationen genomförs enligt fabrikens anvisningar så att din utrustning arbetar med högsta effektivitet.

Follett LLC ansvarar inte för följdskador, kostnader, avgifter eller förluster som orsakats av fel på maskinen.

Fullständiga garantivillkor finns på vår hemsida www.follettice.com/productwarranties.

Garantiregistrering och utvärdering av utrustning är viktig för oss så att vi kan följa upp vår utrustning och dess funktion. Vi vill att du registrerar Folletts utrustningsgaranti på vår hemsida www.follettice.com/support, där du väljer Garantiregistrering och produktutvärdering. Det är enkelt att göra, så ta dig tid en minut och registrera dig idag. Det finns också utrymme på blanketten för kommentarer och synpunkter. Berätta för oss vad du tycker så att vi kan använda det i våra ansträngningar att alltid bli bättre.

Vi är stolta över att producera överlägsen utrustning och vi arbetar hårt med att stötta den med överlägset kundansvar och tekniskt stöd. Tala om för oss vad vi kan göra mer för att hjälpa dig. Vi svarar gärna på dina frågor.

Warranty Registration and Equipment Evaluation

Thank you for purchasing Follett® equipment. We hope you find that our equipment meets or exceeds your expectations, as our goal is to deliver high value products and services that earn your complete satisfaction!

Please review the enclosed installation and operations manual. It is important that the installation be performed to factory specifications, so your equipment operates to its maximum efficiency.

Follett LLC will not be liable for any consequential damages, expenses, connecting or disconnecting charges or any losses resulting from a defect of the machine.

For full warranty details, visit our website www.follettice.com/productwarranties.

Warranty registration and equipment evaluation is important to help us keep track of our equipment and to record the machine's performance. We request that you register Follett equipment warranties on our website www.follettice.com/support and choose Warranty Registration and Equipment Evaluation. It's simple to do; please take a moment to register today. There is also space on the form to provide us with comments and feedback. Please let us know about your experience so we can capture it for our continuous improvement efforts.

We pride ourselves on producing outstanding equipment and we work hard to back it up with outstanding customer and technical support. Please let us know what else we can do to assist you. We would be happy to answer your questions.

SafeCLEAN, SensorSAFE, Maestro Plus, Symphony Plus, Quiet Night and Sani-Sponge are trademarks of Follett LLC. Follett and RIDE are registered trademarks of Follett LLC, registered in US.