

# Horizon Elite™ Ice Machine Models with RIDE™ Technology Installation Instructions for Vision™

D714, E714, C1014, C1414

Order parts online  
[www.follettice.com](http://www.follettice.com)

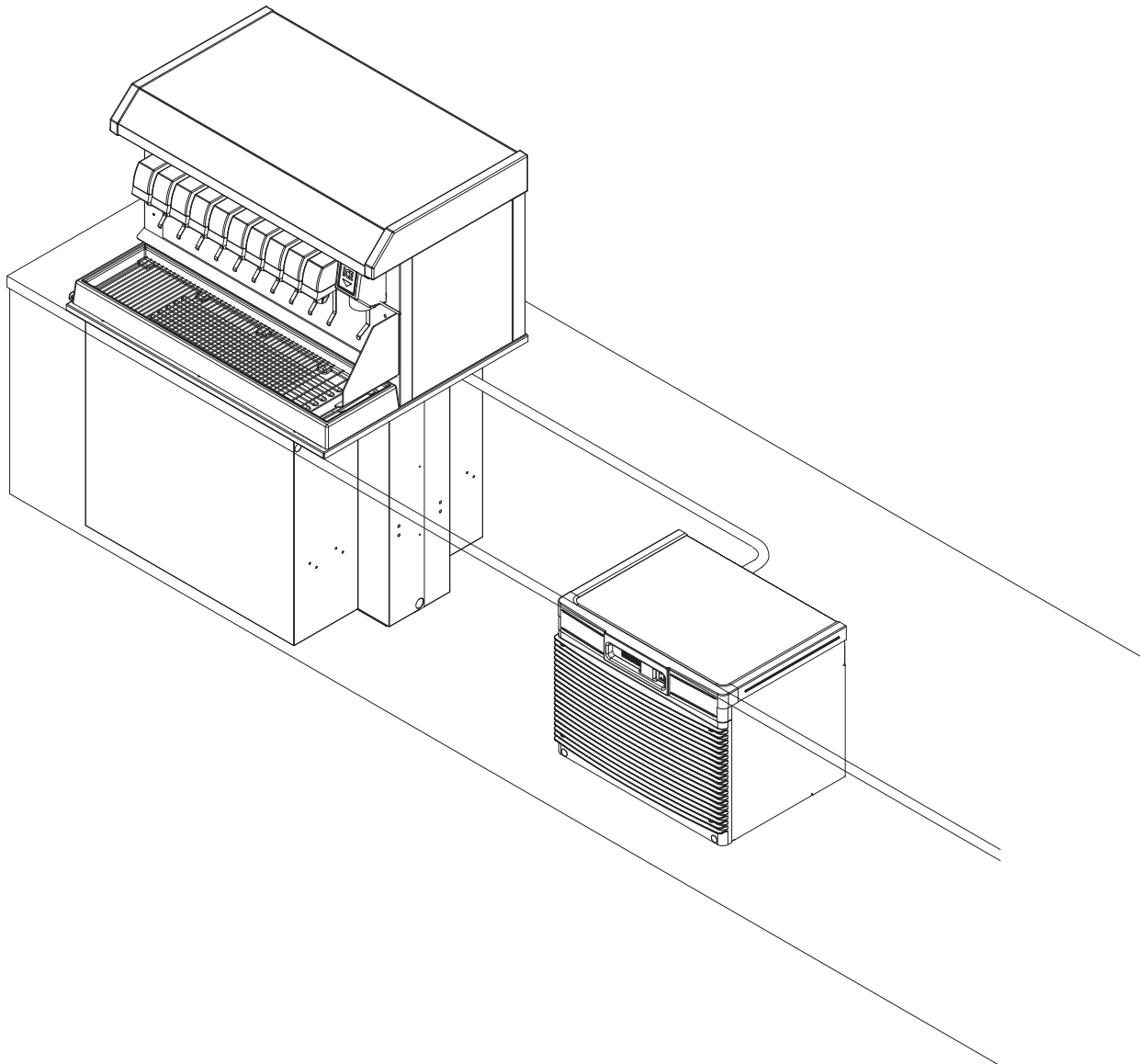
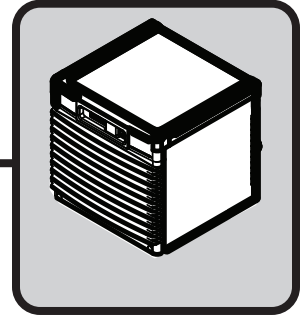

801 Church Lane • Easton, PA 18040, USA  
Toll free (877) 612-5086 • +1 (610) 252-7301  
[www.follettice.com](http://www.follettice.com)

01113208R07

 **CAUTION!**

- This appliance should be connected by a qualified person in accordance with applicable codes.
- If the supply cord is damaged, it must be replaced by the manufacturer, its service agent or similarly qualified persons in order to avoid a hazard.
- Connect to potable water supply only.
- This appliance can be used by children aged 8 years and above and persons with reduced physical, sensory, or mental capabilities, or lack of experience and knowledge if they have been given supervision or instruction concerning use of the appliance in a safe way and understand the hazards involved. Children should be supervised to ensure that they do not play with the appliance.
- This appliance is intended to be used for household and similar applications such as staff kitchen areas in shops, offices and other working environments; farm houses and by clients in hotels, motels and other residential type environments; bed and breakfast type environments; catering and similar non-retail applications.
- **WARNING!** To avoid a hazard due to instability of the appliance, it must be fixed in accordance with the instructions.

Read and complete the following 8 installation steps

1 **Unpack**



2 **Site preparation**



3 **Dispenser preparation**

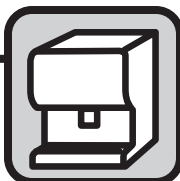

4 **Docking assembly**

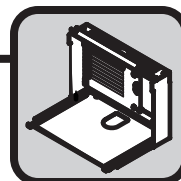

5 **Ice transport tube**



6 **External connection**



7 **Internal connection**

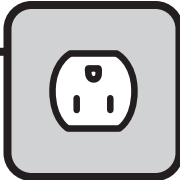

8 **Front cover**

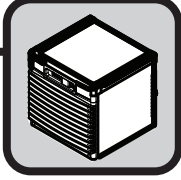

Carefully unpack and inspect the contents of your Follett ice machine.

Unpack

1



### 1.1 Unpack ice machine

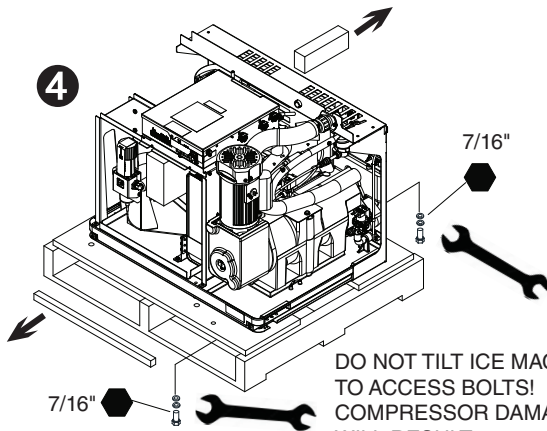
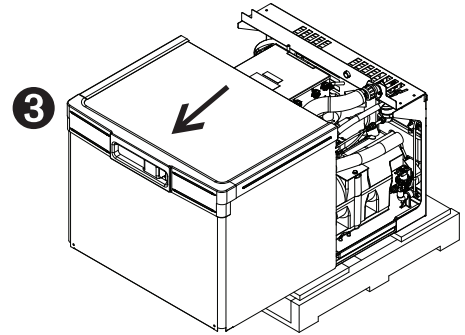
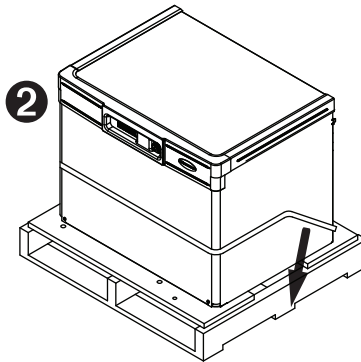
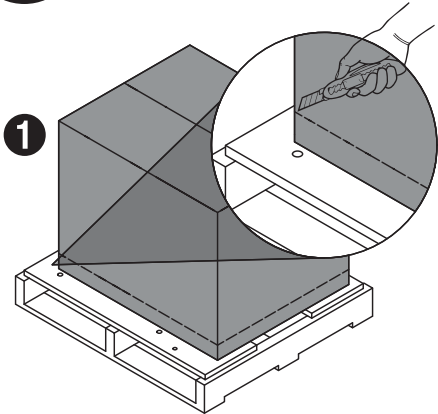

DO NOT TILT ICE MACHINE  
TO ACCESS BOLTS!  
COMPRESSOR DAMAGE  
WILL RESULT

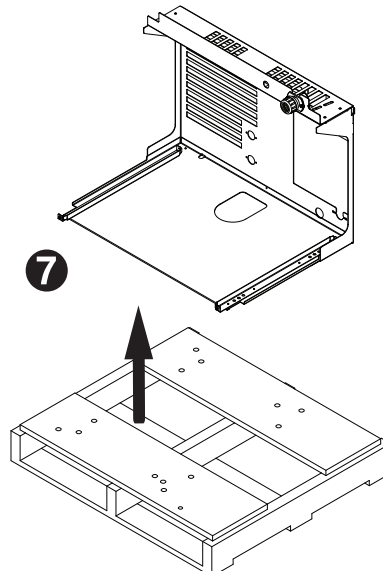
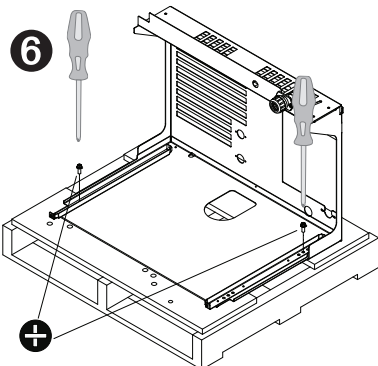
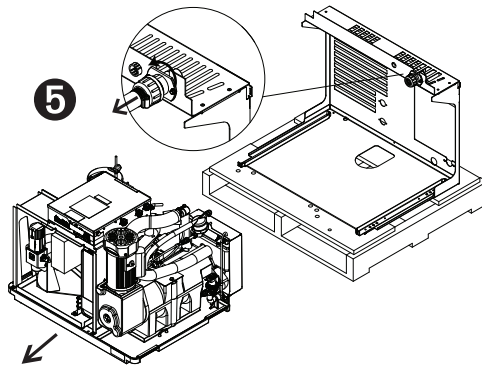

**Prepare the installation site.**

Provide drainage, water supply and electrical power to within 6 feet (2m) of ice machine in accordance with local and national codes. Outdoor installation is not recommended and will void warranty.

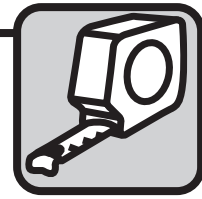

**2.1 Installation site requirements**

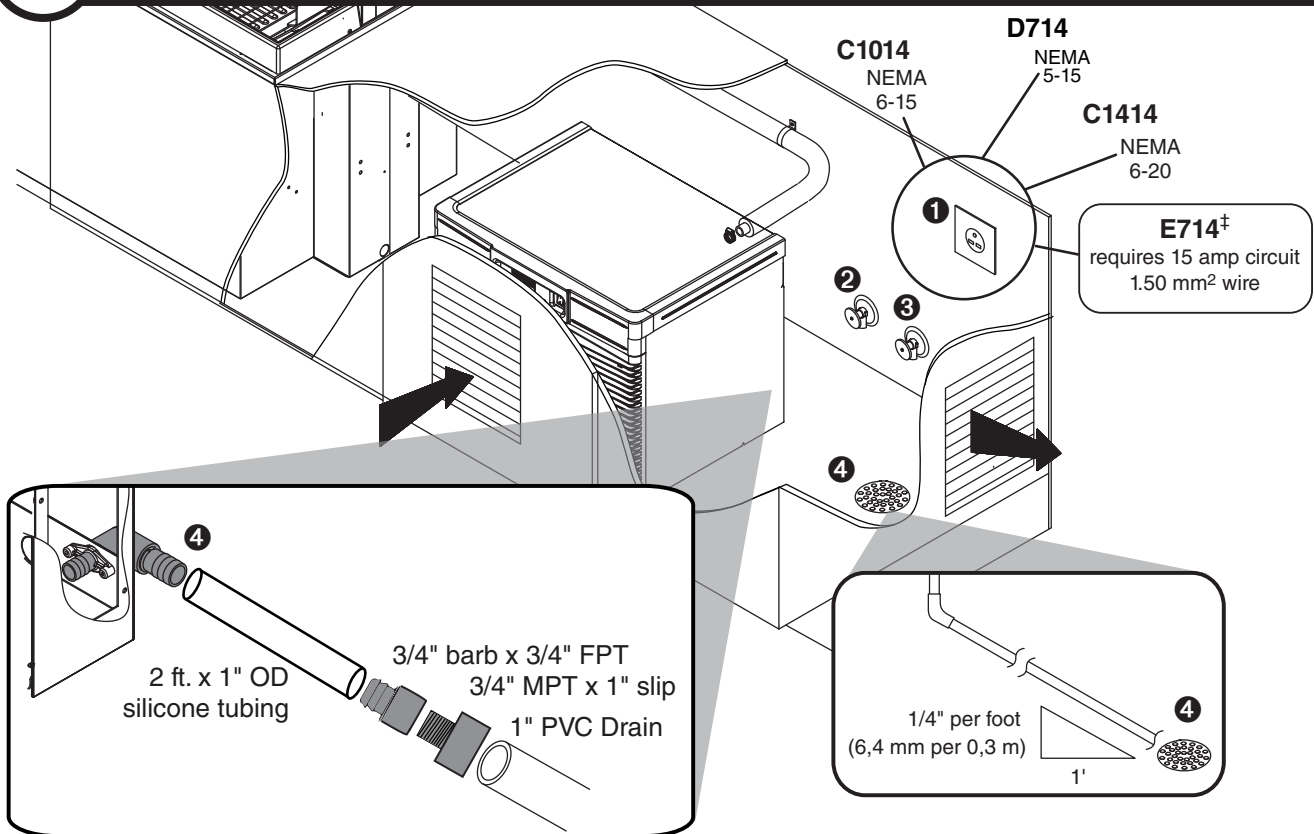

**Electrical 1**

- C1414 208-230/60
  - C1414 208-230/60
  - D714 115/60 (Requires dedicated 15A circuit)
  - E714 230/50<sup>†</sup>
- <sup>†</sup> E714A requires 15A dedicated circuit 1.50 mm<sup>2</sup> wire. Plug must be provided by end user and must conform to standard EN 60 335-2-24 of the end destination.

**Potable water supply 2 (3/8" push-in connection, 3/8" OD tubing required)**

- 10-70 psi (69-483 kpa)
- 45 to 90 F (7 to 32 C)
- Follett recommends the use of an in-line water filtration system (item# 00130286)
- This equipment is to be installed with adequate backflow protection to comply with applicable federal, state, and local codes

**Condenser water supply for water-cooled systems 3 (1/4" FPT inlet, 1/4" FPT outlet)**

- 10 psi min.; 150 psi max. (69 kpa min.; 1034 kpa max.)
- 45 to 90 F (7 to 32 C)
- 1.5 gallons per minute (5.68 liters per minute)

**Drain 4 (3/4" Barb)**

- Minimum 8" radius on silicone drain line. Drain line from the ice machine must have at least 1/4" per foot pitch (6,4 mm/0,3 m).



3.1 Bin Signal Installation

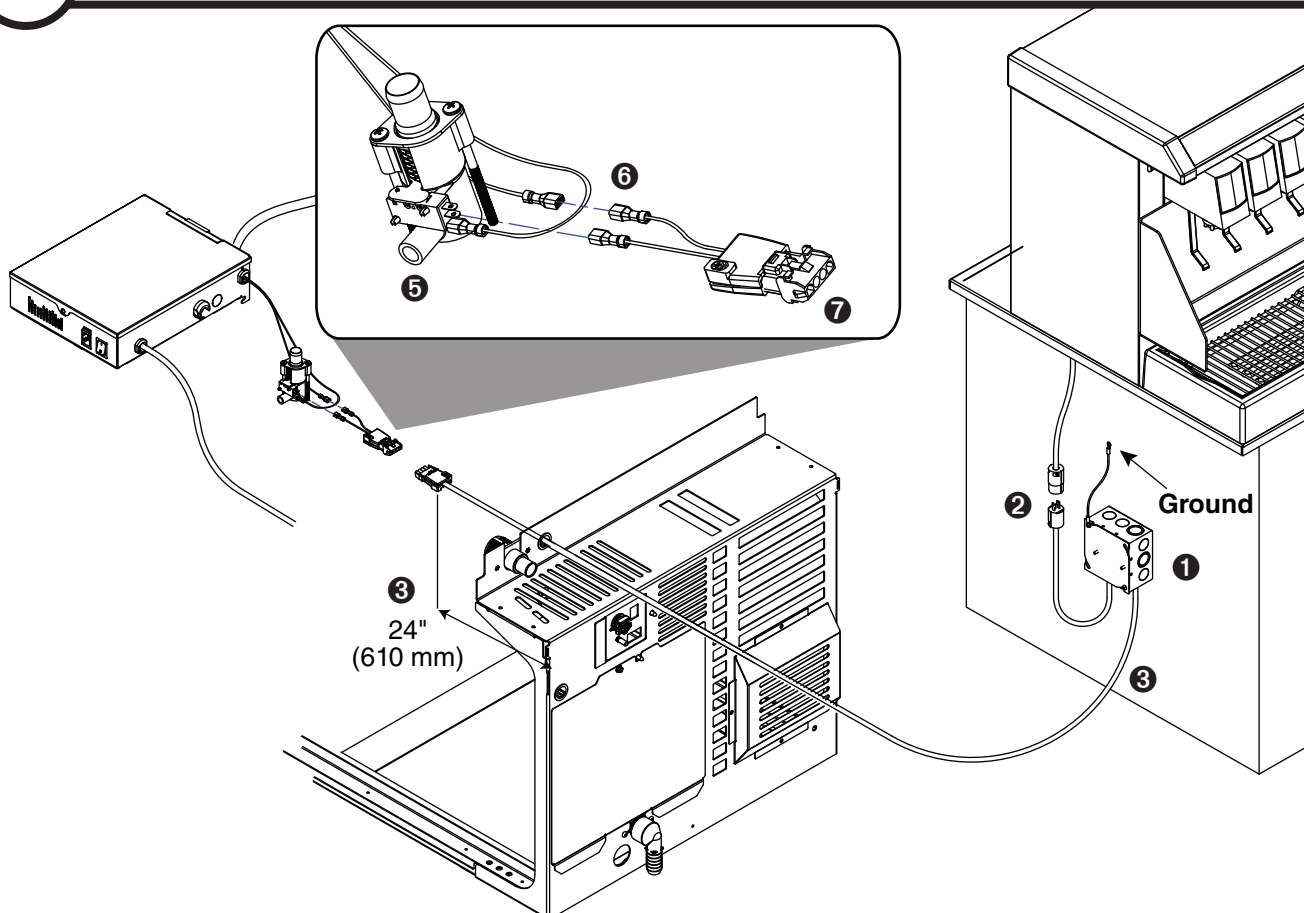

- Mount the electrical box to the side of the Vision dispenser ① to establish a ground connection.  
**Note:** If a 4 x 4 box is mounted to a non-grounded surface, connect ground wire at an appropriate ground.
- Connect the bin signal plug on the electrical box to the bin signal cord on the bin ②
- Insert 16" (609,6 mm) of the long bin signal cable ③ into the hole in the back of the docking station ④ and secure in place with strain relief provided.
- After sliding the ice machine module into the docking station, disconnect one wire from shuttle switch and replace with wire from adapter plug. ⑤
- Connect wire removed from shuttle switch to male connector on adapter plug wire. ⑥
- Complete normal installation procedure for the ice machine using the installation manual that shipped with the ice machine.
- Connect adapter plug into bin signal plug. ⑦

Install the docking assembly.



**BEFORE PROCEEDING**

Prior to installing the docking assembly, ensure that the drain fitting is oriented (right or left) correctly for your installation. An optional straight drain fitting is also supplied. You may need to remove the back panel of the docking assembly in order to re-orient or change the drain fitting. Replace back panel prior to mounting the docking assembly.

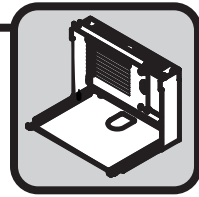

**Wall bracket accessory**

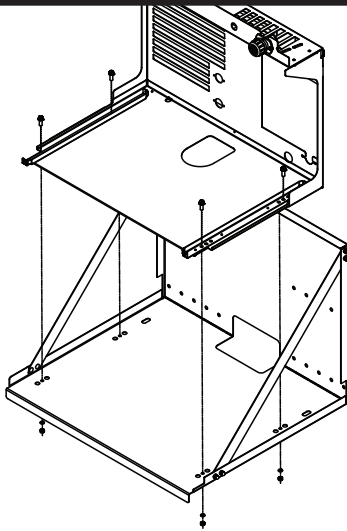

- Mount docking assembly to wall bracket accessory

**Machine stand accessory**

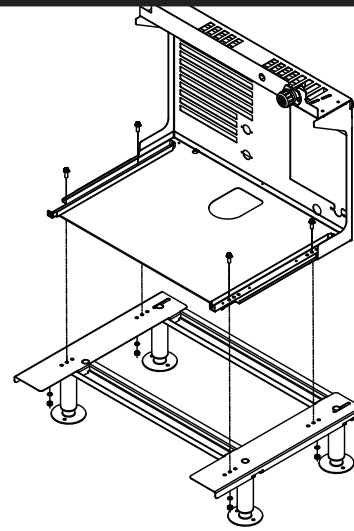

- Mount docking assembly to machine stand accessory

**4.1 Undercounter installation requirements**

Please refer to the Horizon Elite Ice Machine Undercounter Kit instructions.

Install the ice transport tube.

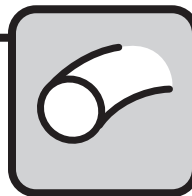

### 5.1 Ice transport tube installation.

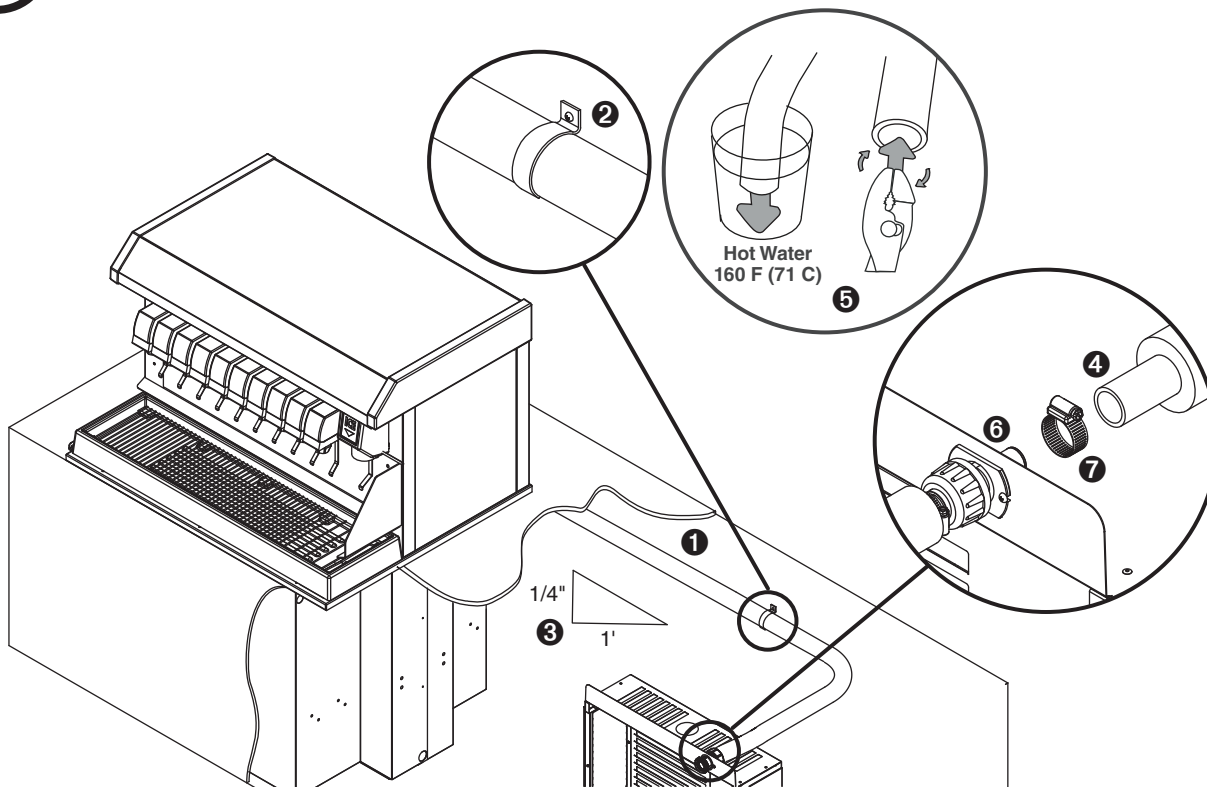

#### Ice transport tube tips

- One end of the ice transport tube has 1/8" holes drilled into it; this end connects on the inside of the Vision dispenser.
- Insulate entire length of ice transport tube ❶
- Secure ice transport tube ❷ as needed to prevent dips and traps from forming. For long tube runs see guide on page 18.
- Pitch tube at least 1/4" per foot (6,4 mm/0,3m) ❸
- Ice transport tube must drain towards ice machine

#### Ice transport tube to Ice machine

- Be sure tube ends are square ❹
- Heat end of transport tube in cup of 160 F (71 C) hot water to soften and spread with pliers ❺ before making connection to ease assembly
- Push plug end of ice transport tube onto ice machine nipple ❻
- Install hose clamp ❼ tightly so tube swells, ensuring hose clamp is installed on barb

## 5.2 Dispenser ice transport tube installation

### Ice tube retainer bracket

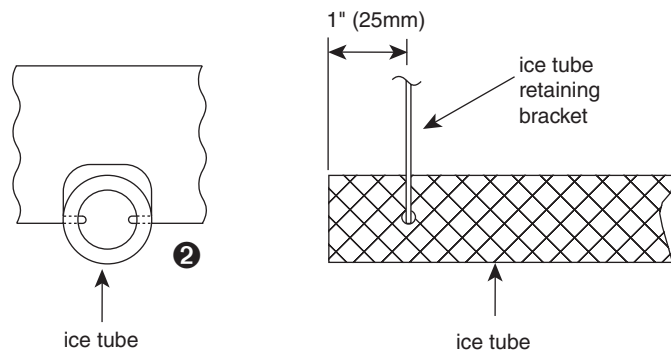

### Front View VU155

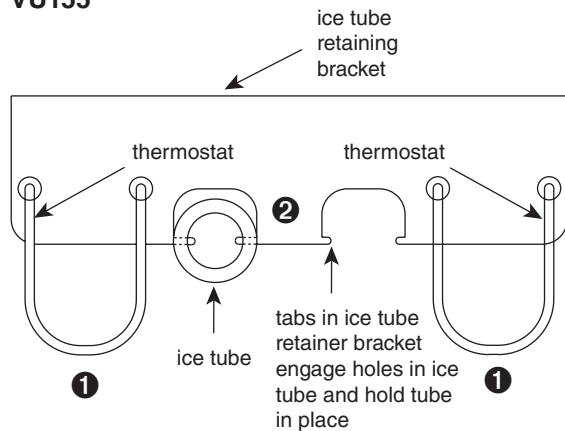

### Front View VU300

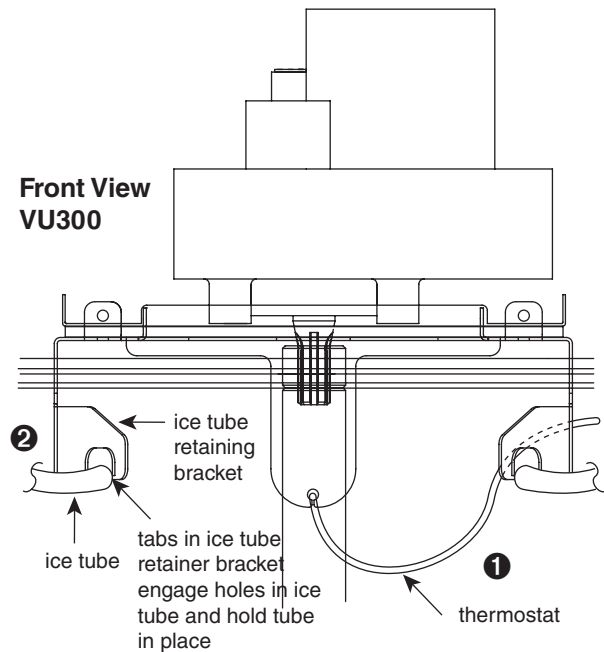

- One end of the ice transport tube has 1/8" holes drilled into it; this end connects on the inside of the Vision dispenser.
- Push one end of ice transport tube(s) through hole(s) provided in side of dispenser
- Route tube into ice tube bracket inside dispenser and engage bracket tabs in holes located in end of ice transport tube(s) ①
- Verify bin thermostat capillary tube is mounted correctly ②

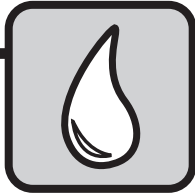

Connect utilities to docking assembly.

6.1 Air-cooled ice machines only

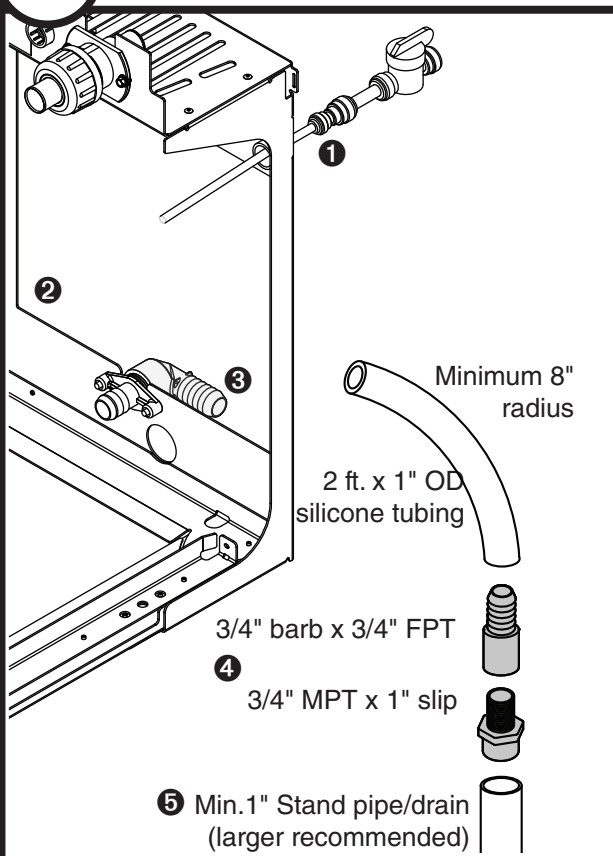

- Rough-in ice machine potable water supply ①. 3/8" push-in connection will be made at included shut-off valve then into solenoid.
  - Remove access panel if necessary ②.
  - Connect the silicone tubing to the ice machine 3/4" drain barb ③.
  - Assemble the 3/4" barb x 3/4" FPT to the 3/4" MPT x 1" slip. Connect the other end of the silicone tubing to the 3/4" barb ④.
  - Connect the 1" slip fitting to the 1" stand pipe/drain ⑤.
- Note:** Minimum 8" radius on silicone drain line. Drain line from the ice machine must have at least 1/4" per foot pitch (6,4 mm/0,3 m).
- Apply Petrol-gel to barbed drain fitting ⑥
  - Replace access panel.

6.2 Water-cooled ice machines only

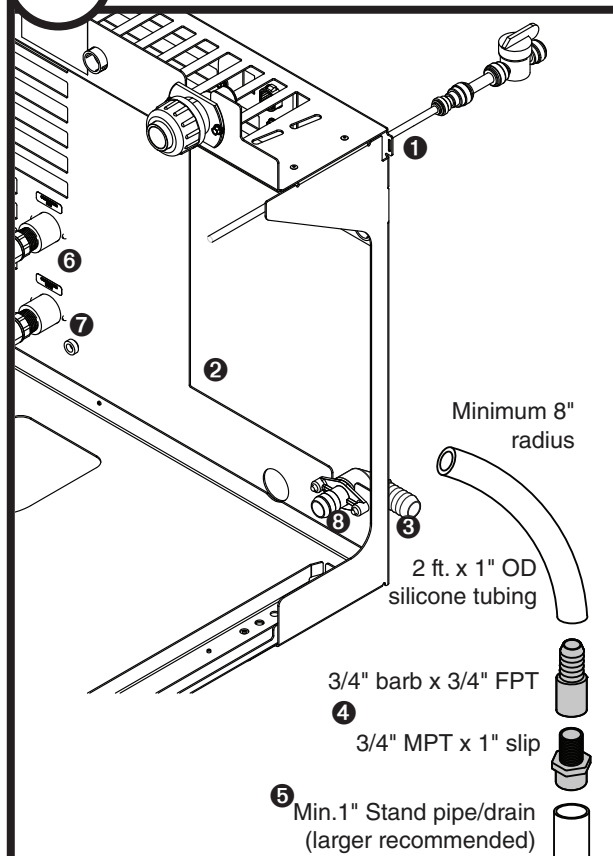

- Rough-in ice machine potable water supply ①. 3/8" push-in connection will be made at included shut-off valve then into solenoid.
  - Remove access panel if necessary ②.
  - Connect the silicone tubing to the ice machine 3/4" drain barb ③.
  - Assemble the 3/4" barb x 3/4" FPT to the 3/4" MPT x 1" slip. Connect the other end of the silicone tubing to the 3/4" barb ④.
  - Connect the 1" slip fitting to the 1" stand pipe/drain ⑤.
- Note:** Minimum 8" radius on silicone drain line. Drain line from the ice machine must have at least 1/4" per foot pitch (6,4 mm/0,3 m).
- Connect cooling water supply ⑥ and return ⑦
  - Apply Petrol-gel to barbed drain fitting ⑧
  - Replace access panel.

### Chassis drain plumbing - required

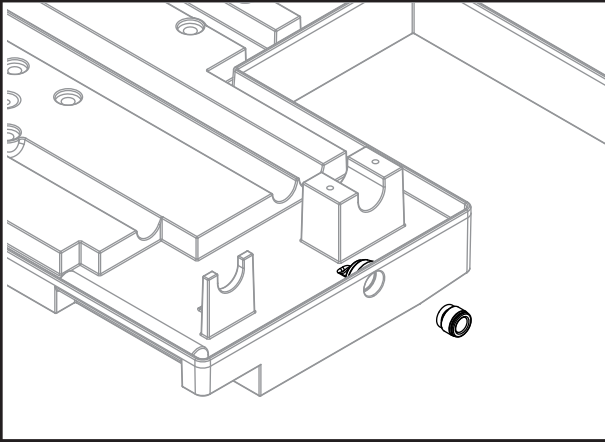

- Route 3/8" drain tubing through knockout in back of docking station and insert fully into John Guest fitting connection at the rear of the machine chassis. Route other end of 3/8" drain tubing to drain.
- Drain must slope 1/4" inch per foot (6 mm per 30,4 cm).

Connect docking assembly to ice machine.

**CAUTION**

- Plug must be accessible after final installation.
- E714 230/50/1 requires a 15A circuit (1.50 mm<sup>2</sup> wire)

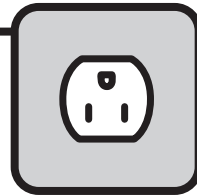

Air-cooled ice machines – follow steps 7.1 through 7.5.

**7.1** Ice transport tube

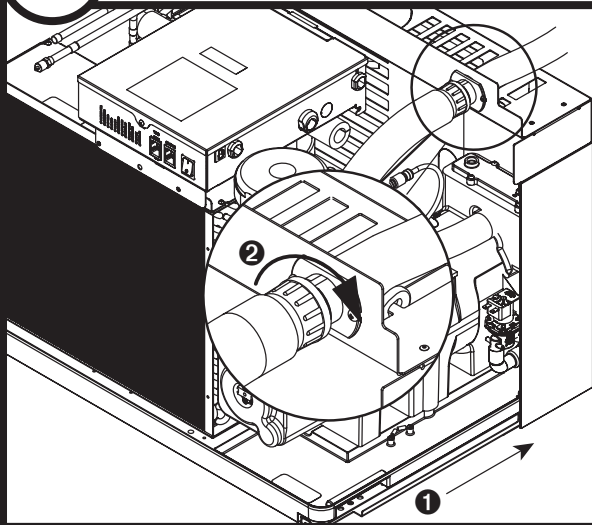

- Slide ice machine into docking assembly ensuring that drain tube is fully seated on barbed drain fitting **1**
- Insert ice transport tube all the way into coupling and tighten nut firmly **2**

**7.2** Shut-off valve, and potable water line options

If this is an undercounter installation:

- Locate the shut-off valve *inside* the machine. Insert potable water line into shut-off valve.

If machine will not be installed under-counter:

- Insert potable water line into shut-off valve - locate the shut-off valve *outside* the machine.
- Insert outgoing line from shut-off valve into push-in connection of water solenoid.

**7.3** Power cord

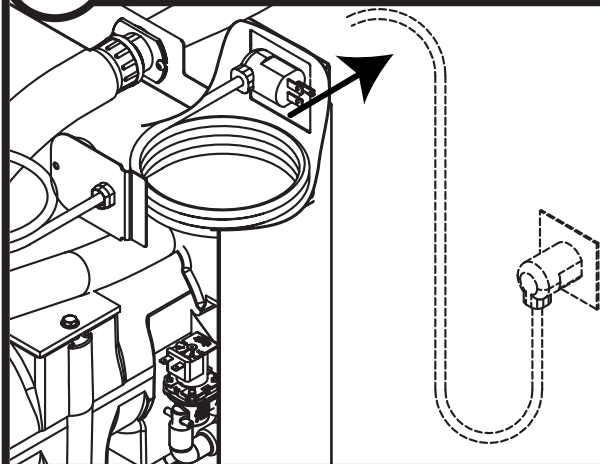

- Remove twist tie
- Carefully pass cord through opening and plug into wall outlet
- For E units, install a suitable plug

**7.4** Power cord

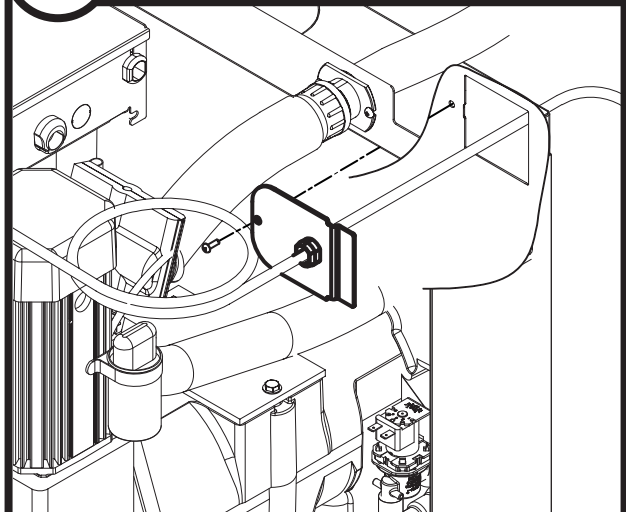

- Position plate into opening and secure with supplied screw

Water-cooled ice machines – follow steps 7.6 through 7.12.

### 7.5 Set TDS switch

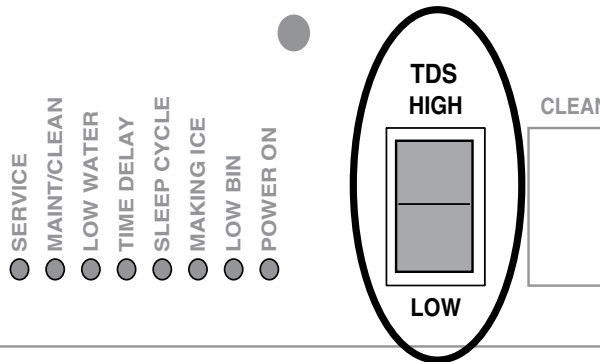

- Set the TDS switch on the electrical box:  
**HIGH:** for extended service life  
**LOW:** for low-scale water

### 7.6 Cooling lines

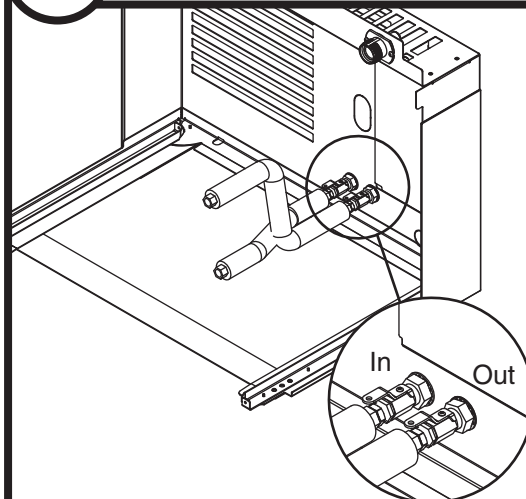

- Install ice machine cooling water lines to docking assembly

### 7.7 Ice transport tube

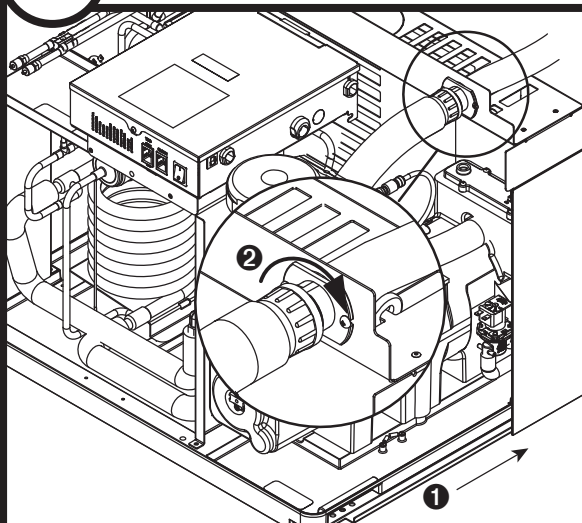

- Slide ice machine into docking assembly ensuring that drain tube is fully seated on barbed drain fitting ①
- Insert ice transport tube into coupling and tighten nut firmly ②

### 7.8 Shut-off valve, and potable water line options

#### If this is an undercounter installation:

- Locate the shut-off valve *inside* the machine. Insert potable water line into shut-off valve.

#### If machine will not be installed under-counter:

- Insert potable water line into shut-off valve - locate the shut-off valve *outside* the machine.
- Insert outgoing line from shut-off valve into push-in connection of water solenoid.

### 7.9 Cooling lines and power

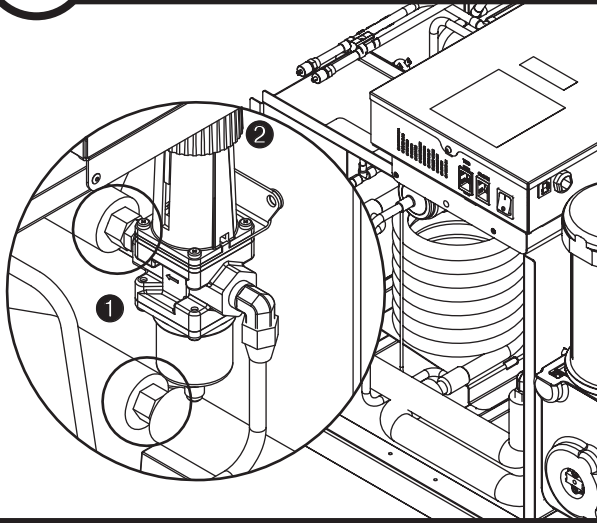

- Connect cooling water lines to ice machine ①
- Water valve is set at the factory. **DO NOT** remove seal or adjust water valve ②

### 7.10 Power cord

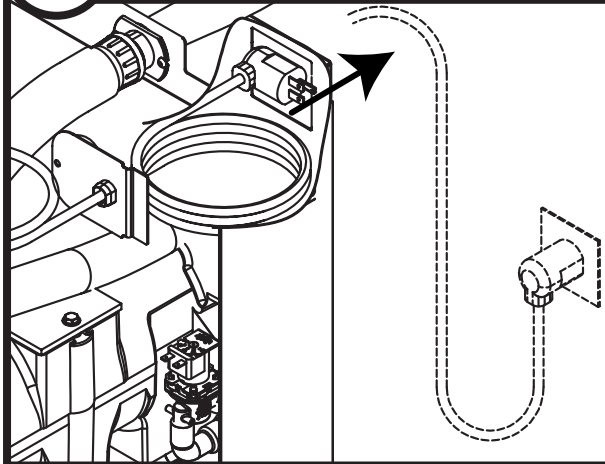

- Remove twist tie
- Carefully pass cord through opening and plug into wall outlet
- For E units, install a suitable plug

### 7.11 Power cord

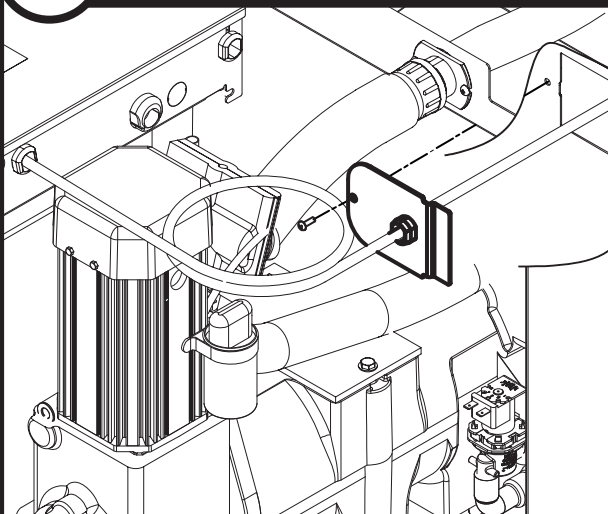

- Position plate into opening and secure with supplied screw

### 7.12 TDS switch

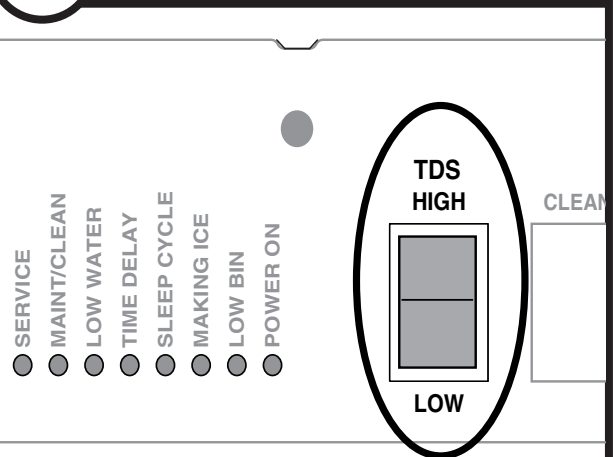

- Set the TDS switch on the electrical box:  
**HIGH:** for extended service life  
**LOW:** for low-scale water

Install front cover to ice machine.

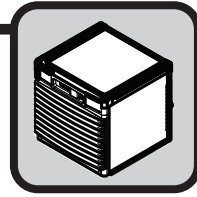

### Front cover installation – air-cooled undercounter only

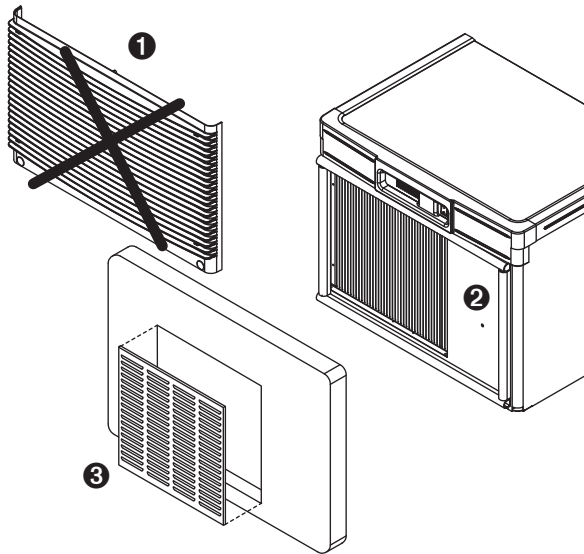

#### CAUTION

- Keep ventilation openings in the appliance enclosure clear of obstruction.
- To ensure proper ventilation (if not using supplied grille) carefully review air circulation specifications in section 4.1
- Remove and discard plastic grille ①
- Apply supplied gasket material around entire opening on skin to prevent air recirculation ②
- Attach supplied metal grille to opening in counter door (see section 4.1) ③

### Install front cover

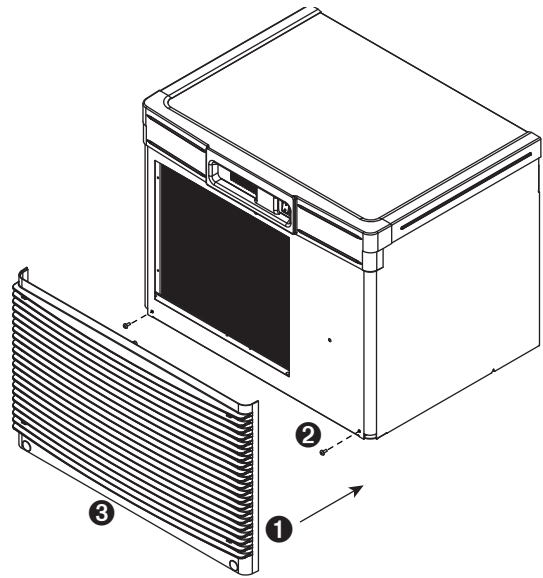

- Slide ice machine cover over machine ensuring that tabs on back of cover slip under louvers on back of docking assembly ①
- Insert and tighten two screws through cover and into docking assembly ②
- For air-cooled machines only, install plastic grille ③

#### NOTICE

**Ice machine MUST be sanitized prior to operation!**

Consult Operation and Service Manual provided with ice machine for sanitizing instructions.

## 9.1 Ice machine start up procedure

The start-up procedure below is intended to ensure that ice machine is operating properly after installation has been made. Check each item listed and call factory immediately for assistance if you experience problems with unit.

### NOTICE!

- Ice machine **MUST** be sanitized prior to operation!
- Consult Operation and Service Manual provided with ice machine for sanitizing instructions.

#### **Before turning on power**

1. Sanitize ice bin.
2. Turn on water to ice machine and check for leaks.

#### **After turning on power**

1. Turn on power switch and immediately press Clean switch to sanitize ice machine. At beginning of sanitizing process, ice machine will purge all water. Check internal and external drain connections for leaks.
2. After sanitizing process, ice machine will start. Confirm that gearmotor, fan motor and compressor start immediately.
3. Check that ice begins to enter dispenser bin area within approximately 10 minutes.

## Long tube run recommendations

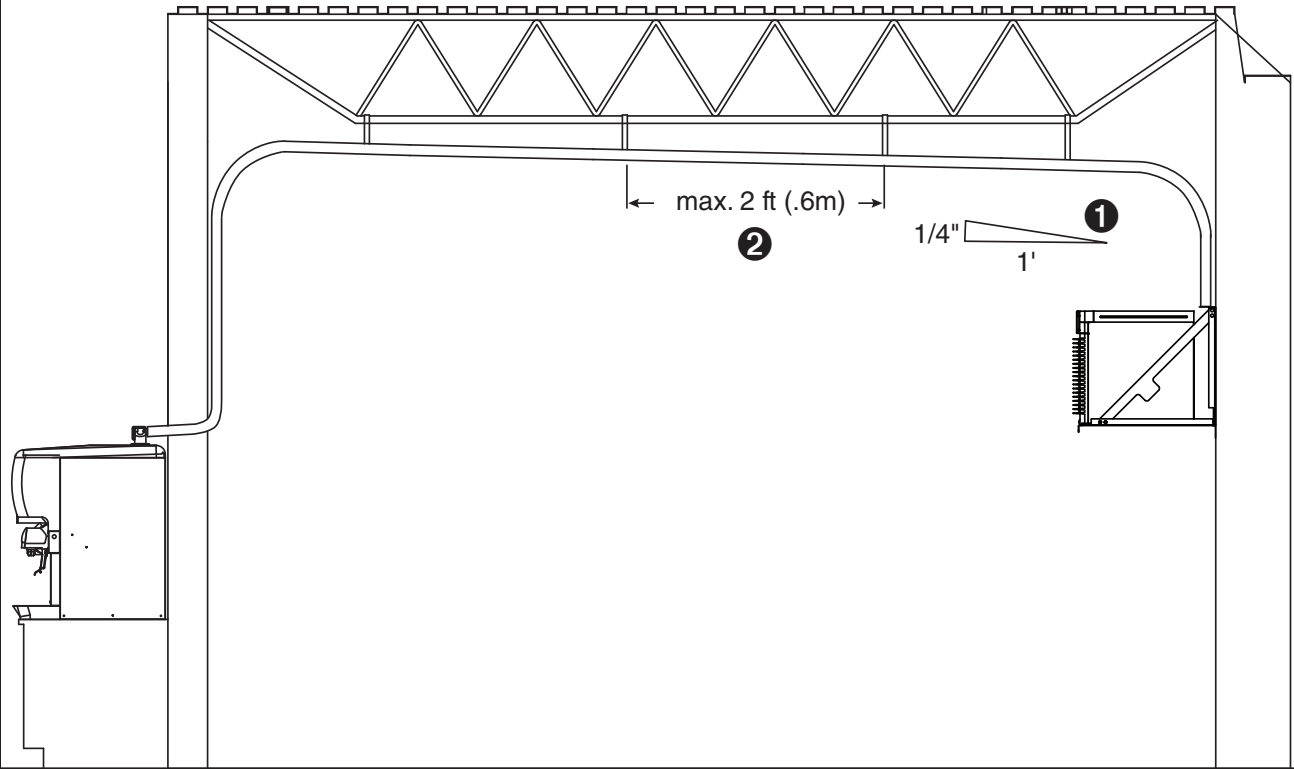

- Pitch ice transport tube to allow melt water to drain towards ice machine ①
- Secure insulated ice transport tube at least every 2 ft (0,6 m) to prevent dips or traps ②





Maestro, Vision, Ice Manager, Horizon, Horizon Elite are trademarks of Follett Products, LLC.  
Chewblet, RIDE, Follett are registered trademarks of Follett Products, LLC.



801 Church Lane • Easton, PA 18040, USA  
Toll free (877) 612-5086 • +1 (610) 252-7301  
[www.follettice.com](http://www.follettice.com)

01113208R07  
© Follett Products, LLC 2/26