

# Horizon Elite™ Ice Machine Installation Instructions for Ice and Beverage Top-mount Applications

D714, E714, C1014, C1414

Order parts online  
[www.follettice.com](http://www.follettice.com)

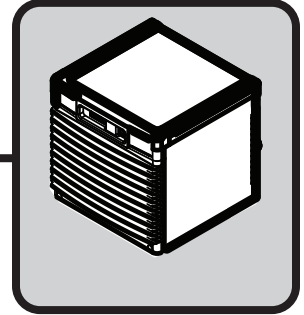

**Horizon Elite top-mount ice machines  
fit most countertop dispensers manufactured by  
Cornelius • Lancer • Servend**

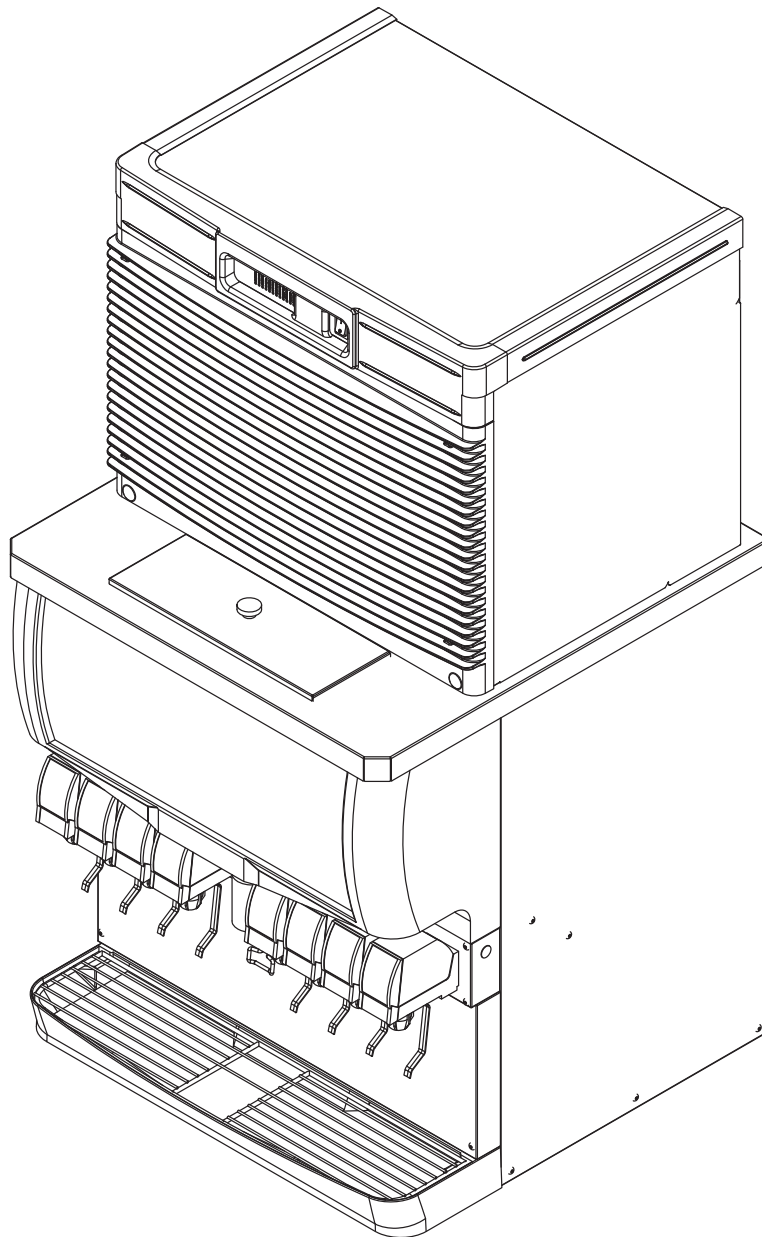

 **CAUTION!**

- This appliance should be connected by a qualified person in accordance with applicable codes.
- If the supply cord is damaged, it must be replaced by the manufacturer, its service agent or similarly qualified persons in order to avoid a hazard.
- Connect to potable water supply only.
- This appliance can be used by children aged 8 years and above and persons with reduced physical, sensory, or mental capabilities, or lack of experience and knowledge if they have been given supervision or instruction concerning use of the appliance in a safe way and understand the hazards involved. Children should be supervised to ensure that they do not play with the appliance.
- This appliance is intended to be used for household and similar applications such as staff kitchen areas in shops, offices and other working environments; farm houses and by clients in hotels, motels and other residential type environments; bed and breakfast type environments; catering and similar non-retail applications.
- **WARNING!** To avoid a hazard due to instability of the appliance, it must be fixed in accordance with the instructions.

Carefully unpack and inspect the contents of your ice machine.

Unpack

1



### 1.1 Unpack ice machine

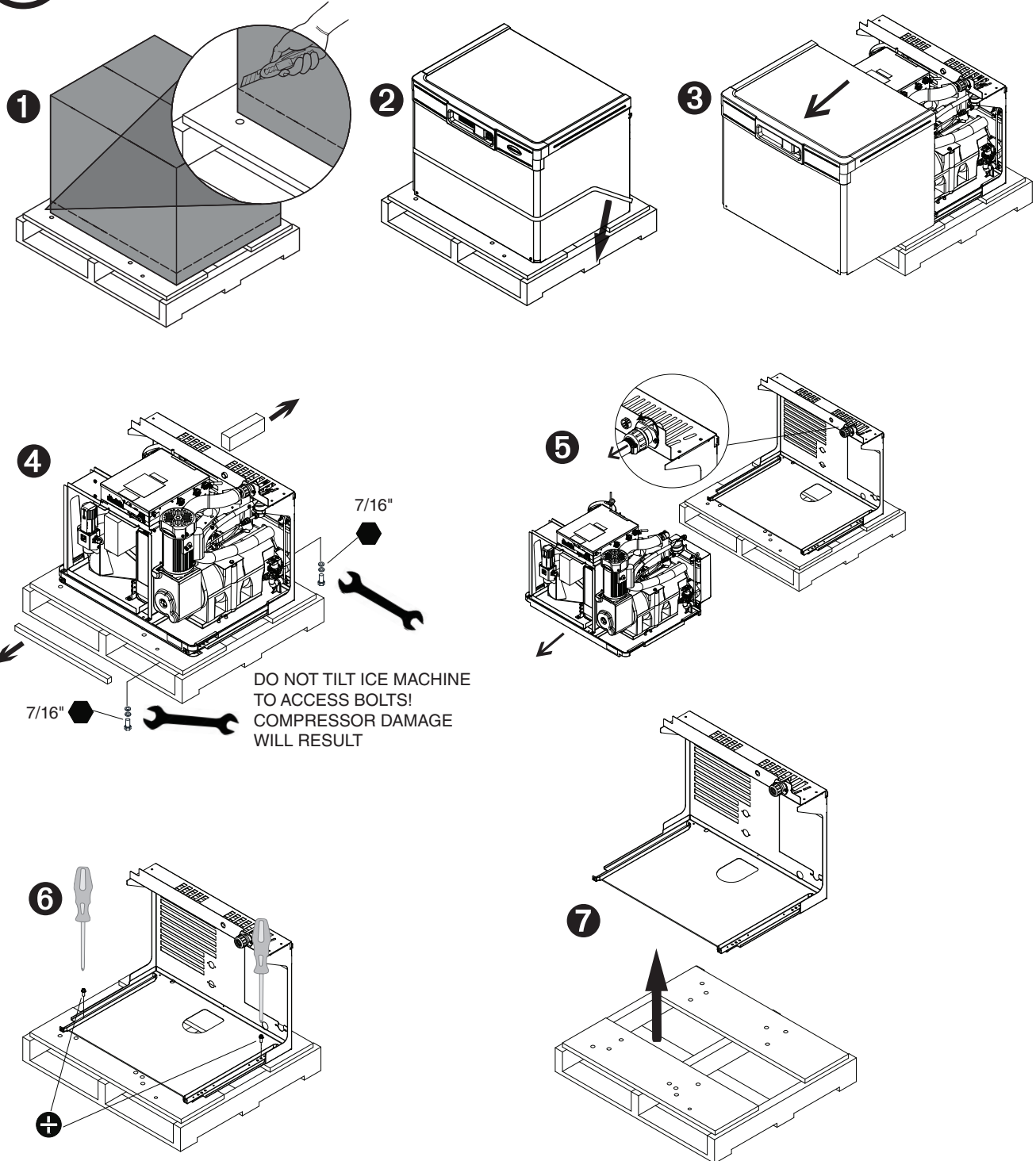

Prepare the installation site.

Provide drainage, water supply and electrical power to within 6 feet (2 m) of ice machine in accordance with local and national codes. Outdoor installation is not recommended and will void warranty.



2.1 Installation site requirements

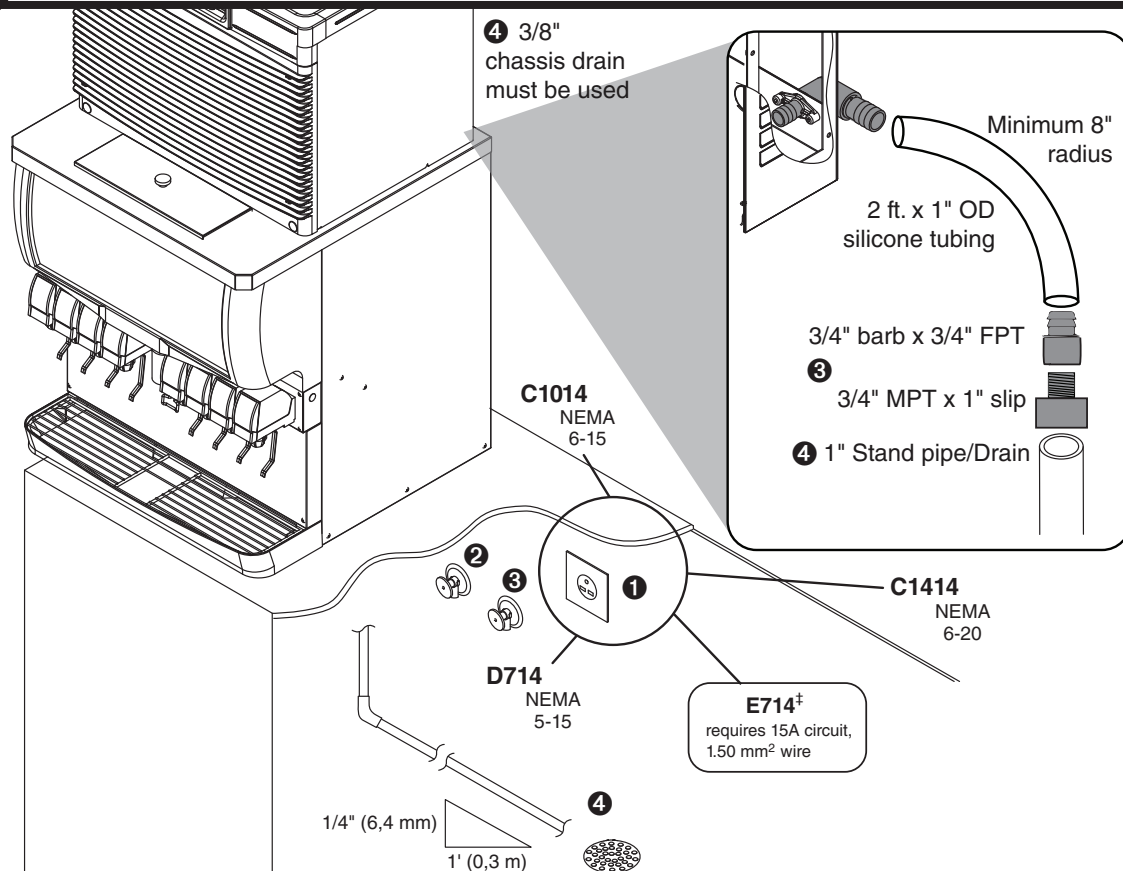

Electrical ①

- C1014/C1414 208-230/60
- D714 115/60 (Requires dedicated 15A circuit)
- E714 230/50<sup>‡</sup>

<sup>‡</sup> E714A requires 15A dedicated circuit 1.50 mm<sup>2</sup> wire. Plug must be provided by end user and must conform to standard EN 60 335-2-24 of the end destination.

Potable water supply ② (3/8" push-in connection, 3/8" OD tubing required)

- 10-70 psi (69-483 kpa)
- 45 to 90 F (7 to 32 C)
- Follett recommends the use of an in-line water filtration system (item# 00130286)
- This equipment is to be installed with adequate backflow protection to comply with applicable federal, state, and local codes

Condenser water supply for water-cooled systems ③ (1/4" FPT inlet, 1/4" FPT outlet)

- 10 psi min.; 150 psi max. (69 kpa min.; 1034 kpa max.)
- 45 to 90 F (7 to 32 C)
- 1.5 gallons per minute (5.68 liters per minute)

Drains: ④ 3/4" Barb for silicone drain, 3/8" push-to-connect for chassis drain

- Minimum 8" radius on silicone drain line. Drain line from the ice machine must have at least 1/4" per foot pitch (6,4 mm/0,3 m).

Prepare the dispenser.

**Note:** The instructions below only apply to 22" and 30" wide dispensers. 44" wide dispenser instructions may be found with the top kit.



3.1 Top preparation – ALL

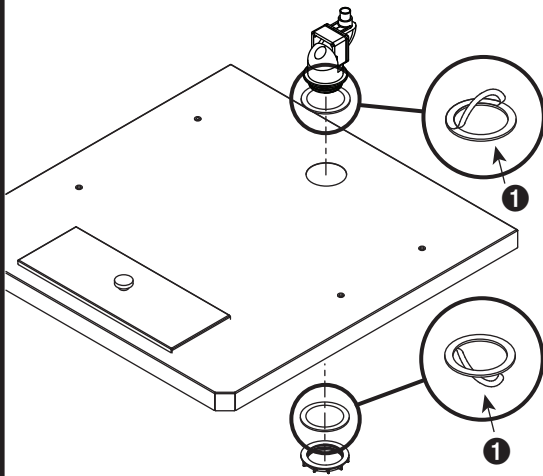

All models

- Remove protective tape from gaskets ①

3.2 Top preparation – ALL

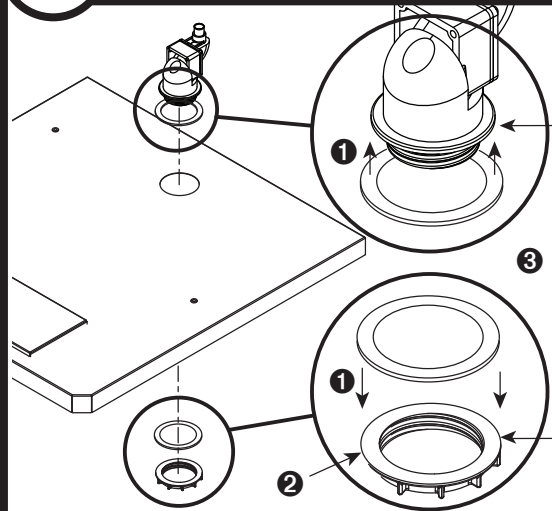

- Apply gaskets ①.
- Install coupling ② through bottom of dispenser top and secure with locking nut ③

3.3 Top preparation – ALL

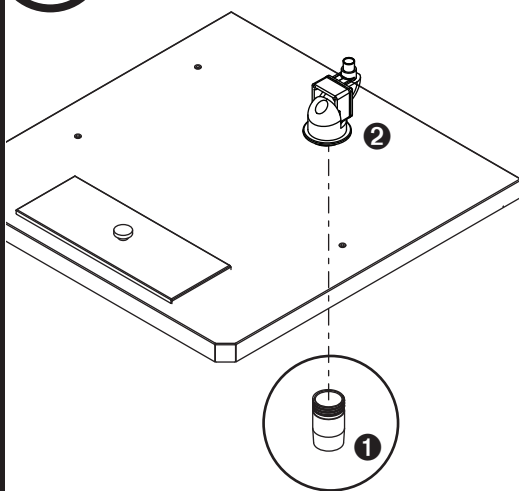

- Screw 4" (102 mm) extension ① into bottom of shuttle actuator ②

3.4 Top preparation – CORNELIUS

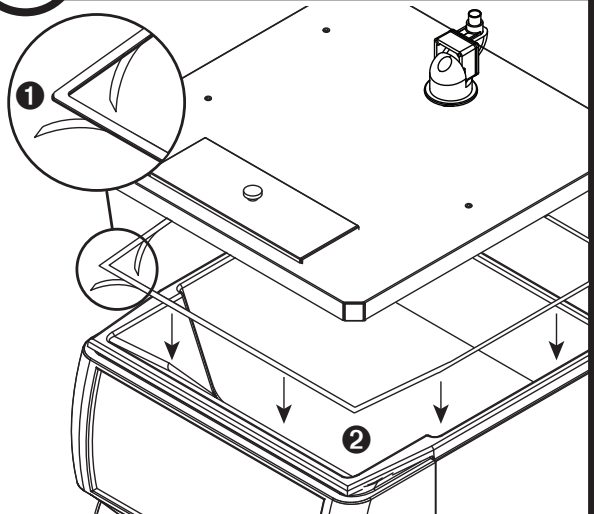

Cornelius models only

- Remove protective tape ①
- Apply gasket ②

### 3.5 Top preparation – LANCER

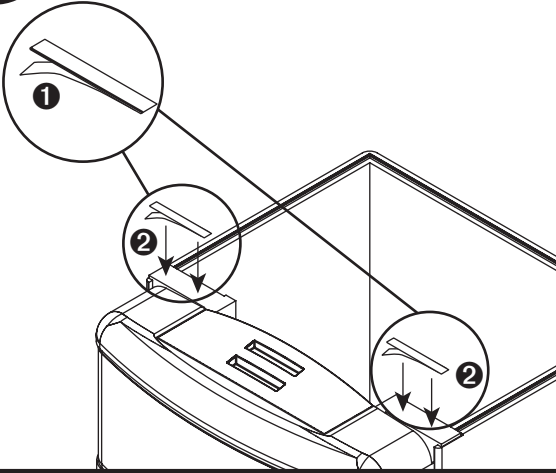

#### Lancer models only

- Remove protective tape ①
- Apply gaskets ②

### 3.6 Agitation adjustments – CORNELIUS

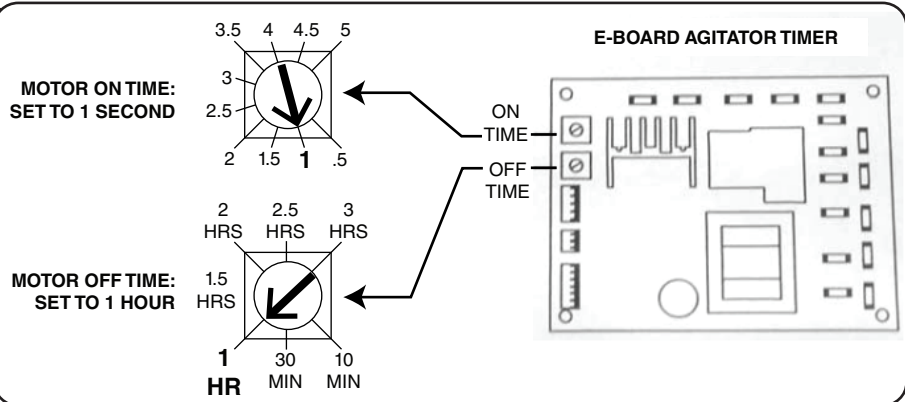
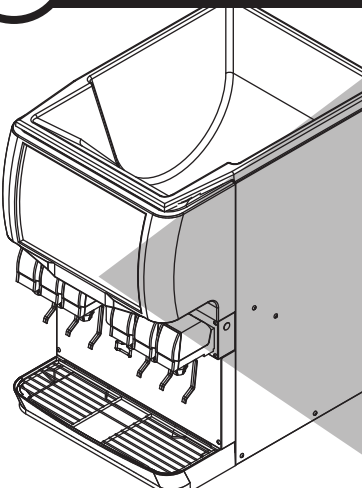

#### Cornelius models ED, DB, DF, IDC and FLAVOR FUSION

Adjust the agitation timer located on the Cornelius PC board to 1 second on, 1 hour off. Note: See Cornelius manual or call Cornelius Technical Service at 1-800-238-3600 for more information.

### 3.7 Agitation adjustments – Coke Freestyle 9000

Call Coca-Cola at 800-241-COKE (2653) and request a Freestyle Senior Tech.

### 3.8 Agitation adjustments – Lancer 4500 Series

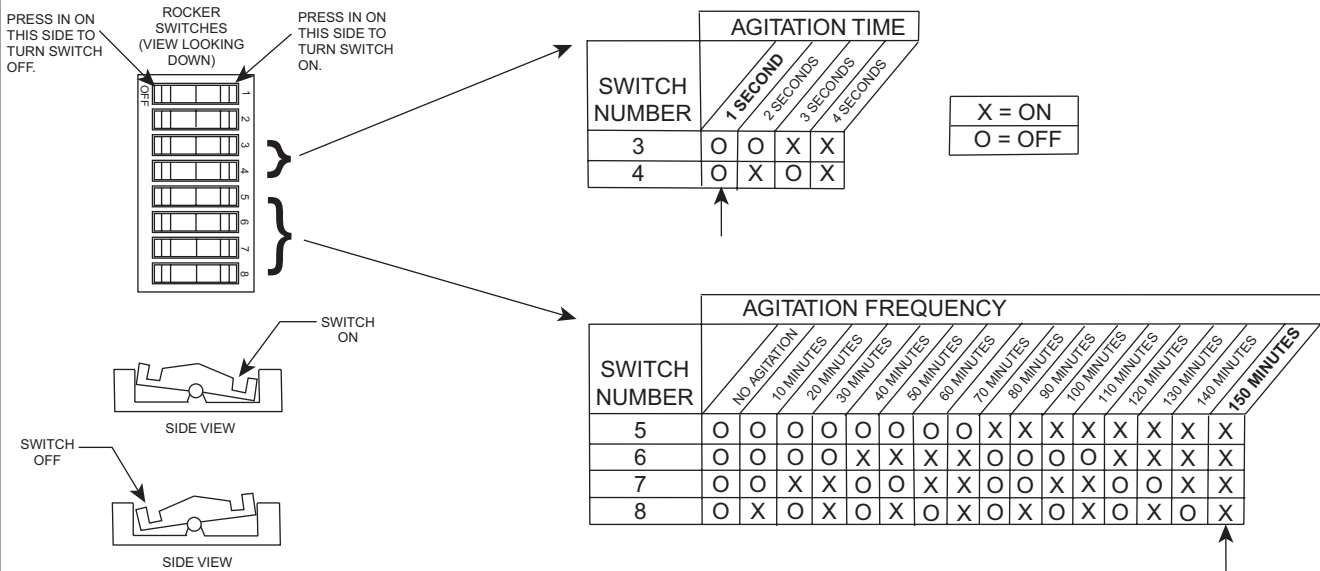

#### Lancer 4500 series only

Adjust the agitation time to 1 second, and the agitation frequency to 150 minutes. See Lancer manual for more information.

### 3.9 Agitation adjustments – Lancer Sensation and Touchpoint

No agitation adjustment required

### 3.10 Agitation adjustments – Lancer FS Series

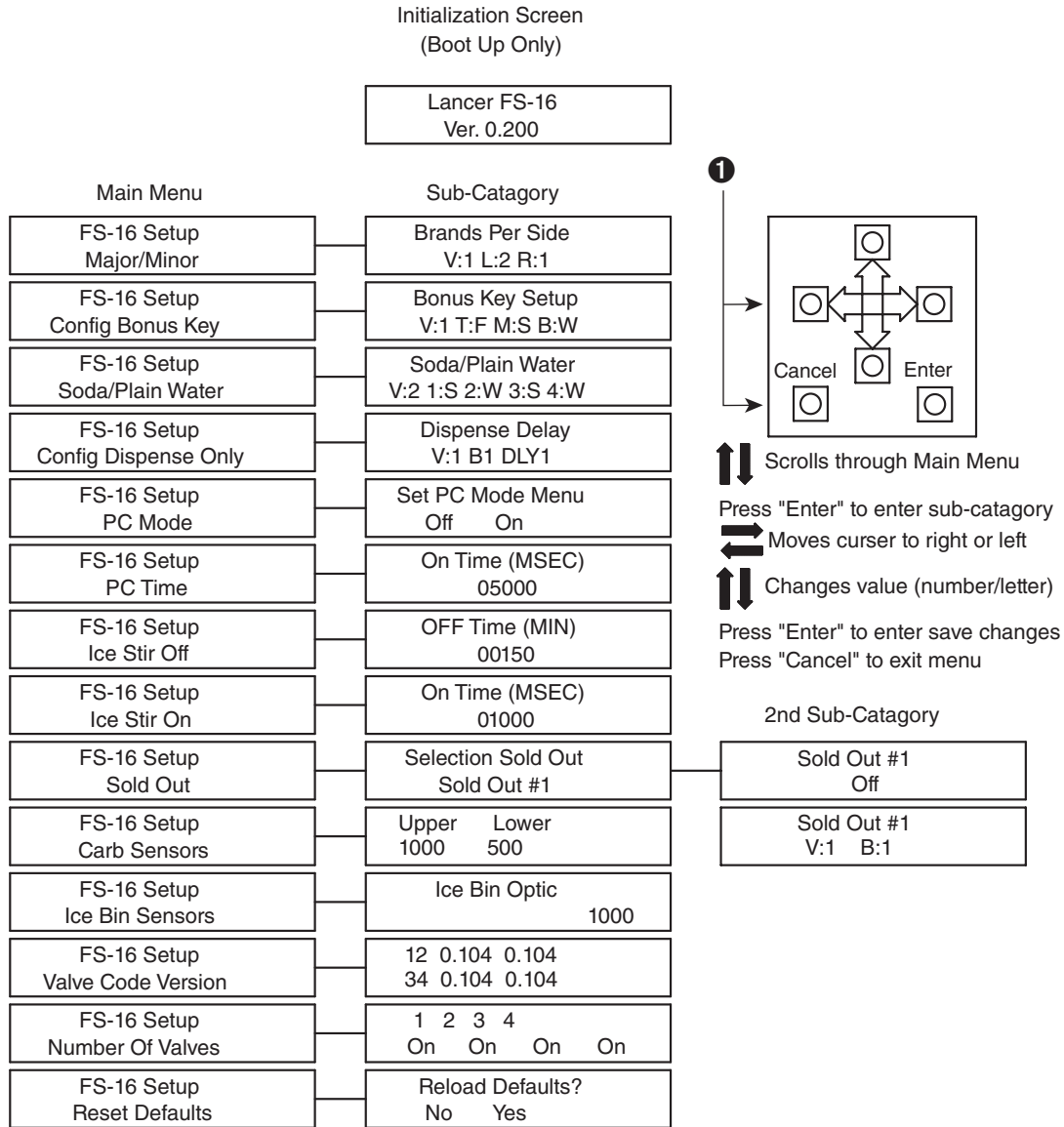

#### Lancer FS series only

- Hold down "cancel" and "left button" to get to hidden menu **1**
- Type in code 6655
- Type in 150 minutes "off time" and 1010 milliseconds (1 second of time) as the preferred setting

**Note:** See Lancer manual or call Lancer Customer Service at 1-888-846-6729 for more information.

### 3.11 Agitation adjustments – Servend

#### Servend models only

No agitation adjustment required.

3.12

Dispenser diverter plate overview (Installation on next page)

Single Agitator

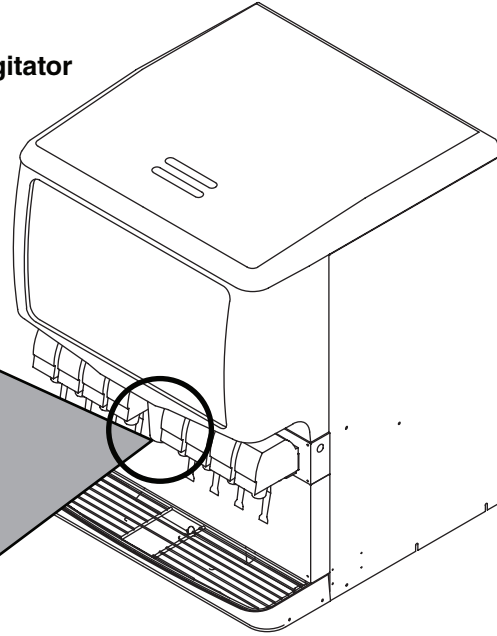
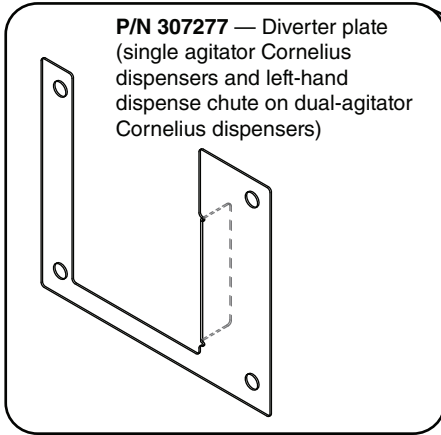

Dual Agitator

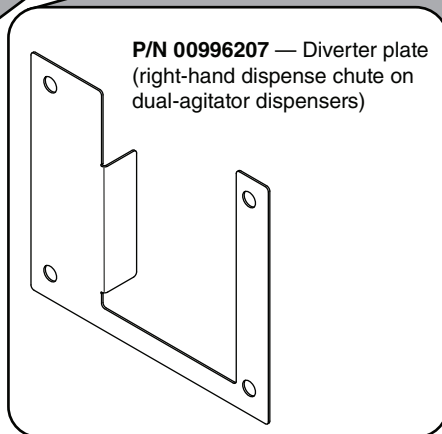
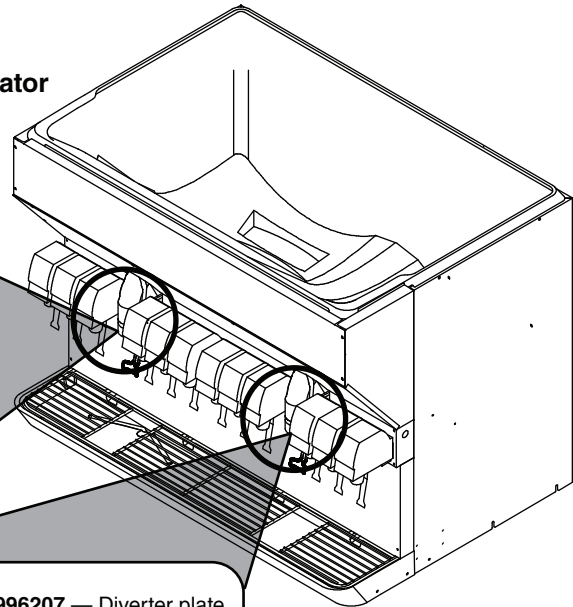
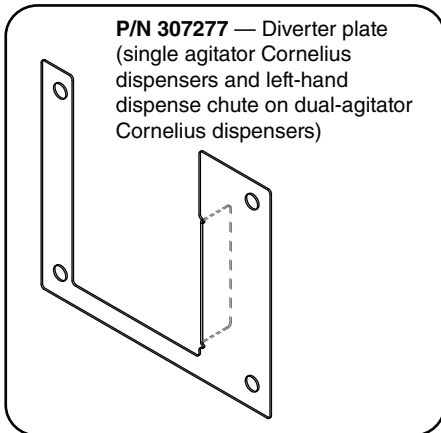

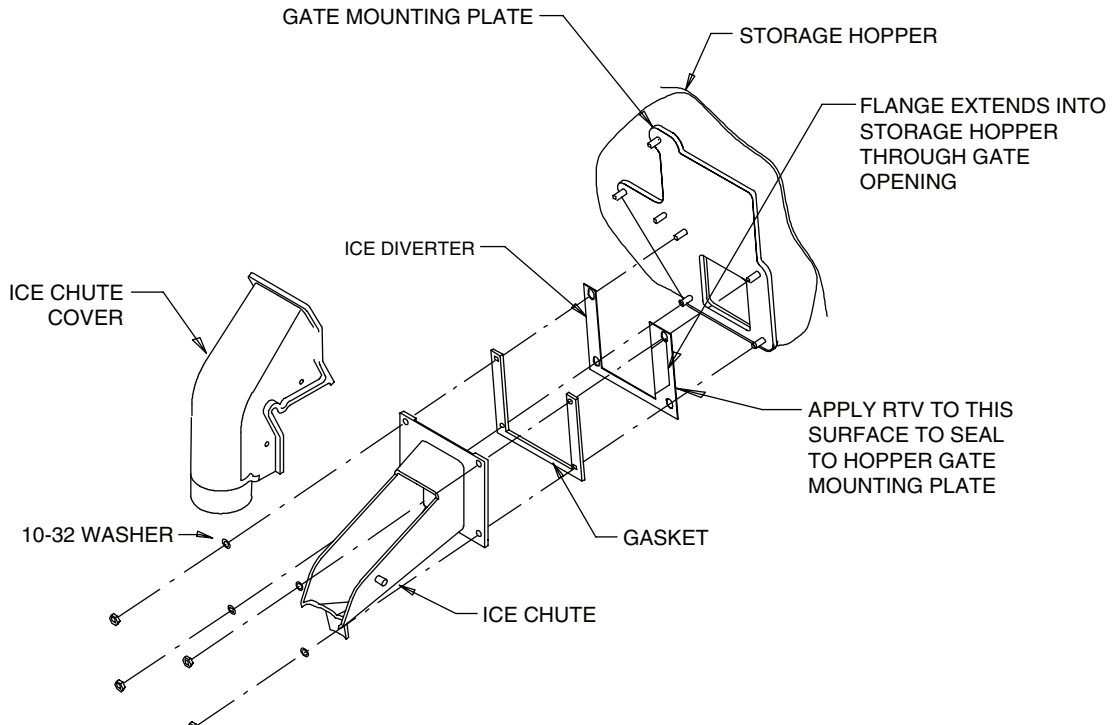
**3.13****Dispenser diverter plate installation – Cornelius ED, DF and DB Series****Cornelius ED, DF and DB series only**

These dispensers require the installation of an ice diverter at the dispenser opening.

- Disassemble chute assembly
- Discard factory restrictor plate
- Replace with alternate diverter plate (supplied)

**3.14****Agitation adjustments – Cornelius IDC and Flavor Fusion**

These dispensers require modifications for compatibility with Chewlet ice. Agitation times must be set to 1 second ON, 1 hour OFF and the ice restrictor plate must be adjusted to the fully open position. See your beverage supplier for these modifications.

Install the docking assembly.



**BEFORE PROCEEDING**

Prior to installing the docking assembly, ensure that the drain fitting is oriented (right or left) correctly for your installation. An optional straight drain fitting is also supplied. You may need to remove the back panel of the docking assembly in order to re-orient or change the drain fitting. Replace back panel prior to mounting the docking assembly.

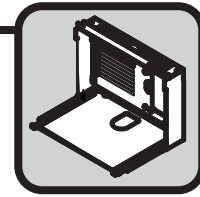

**4.1 Docking assembly**

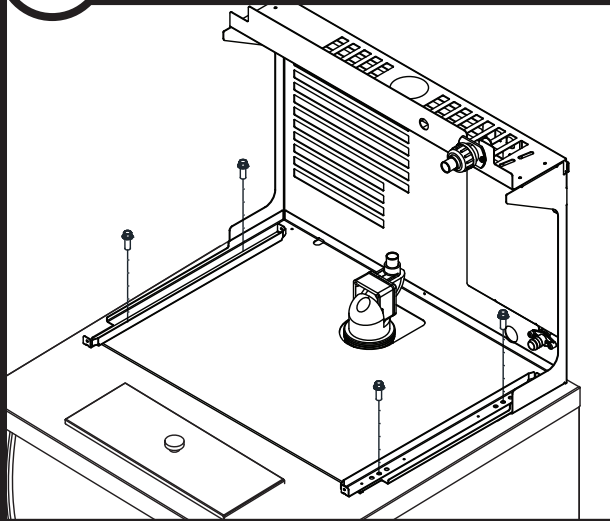

- Mount docking assembly

Install the ice transport tube.

Ice transport tube

5



### 5.1 Ice transport tube installation

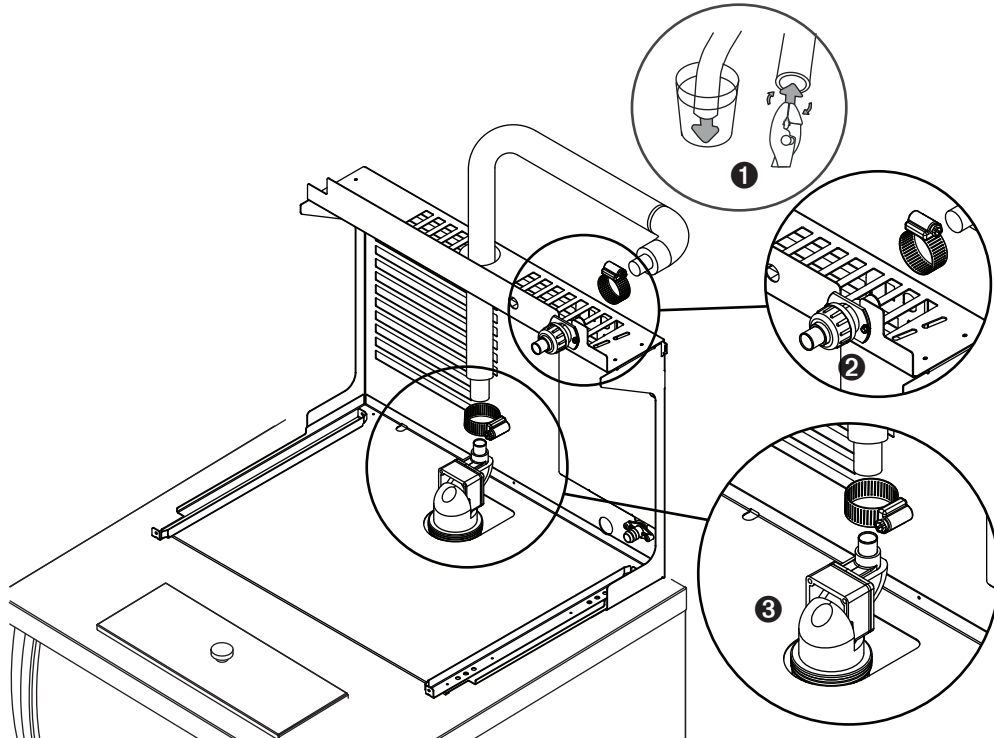

- Install supplied ice transport tube insulation
- Heat end of transport tube in cup of 160 F (71 C) hot water to soften and spread with pliers ❶ before making connection to ease assembly
- Connect ice transport tube to coupling on docking station ❷
- Connect ice transport tube to shuttle actuator ❸

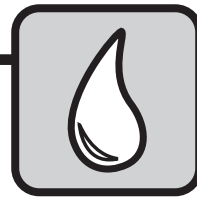

Connect utilities to docking assembly.

**6.1 Air-cooled ice machines only**

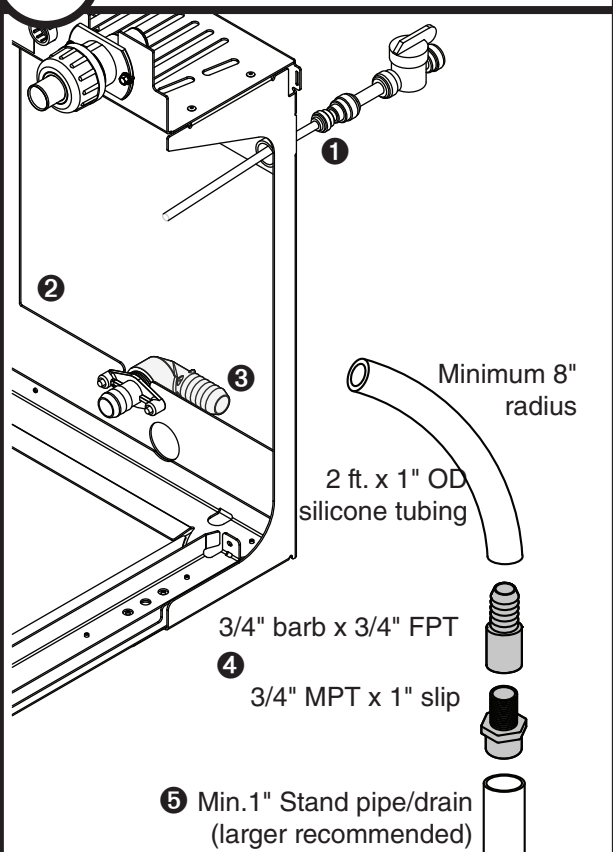

- Rough-in ice machine potable water supply **1**. 3/8" push-in connection will be made at included shut-off valve then into solenoid.
- Remove access panel if necessary **2**.
- Connect the silicone tubing to the ice machine 3/4" drain barb **3**.
- Assemble the 3/4" barb x 3/4" FPT to the 3/4" MPT x 1" slip. Connect the other end of the silicone tubing to the 3/4" barb **4**.
- Connect the 1" slip fitting to the 1" stand pipe/drain **5**.

**Note:** Minimum 8" radius on silicone drain line. Drain line from the ice machine must have at least 1/4" per foot pitch (6,4 mm/0,3 m).

- Apply Petrol-gel to barbed drain fitting **6**
- Replace access panel.

**6.2 Water-cooled ice machines only**

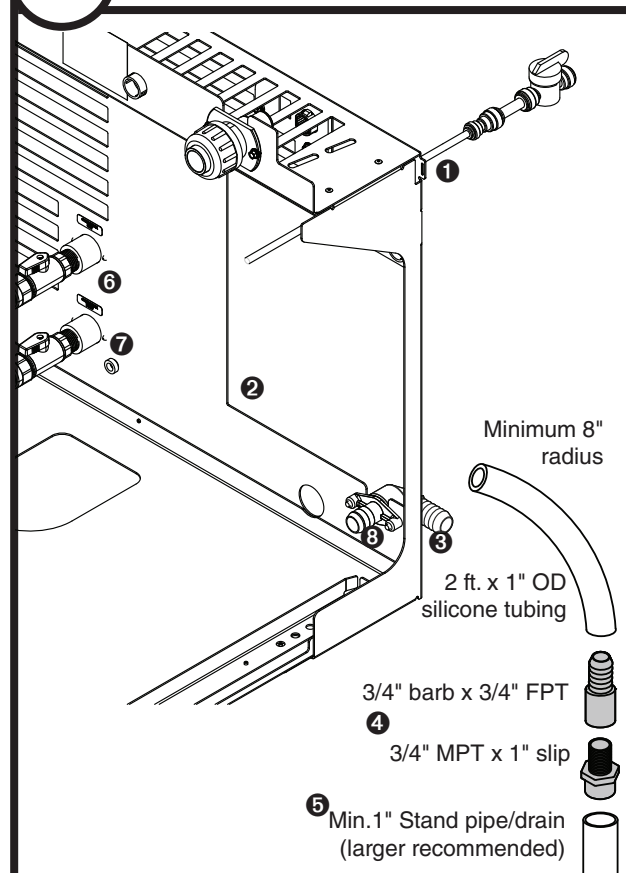

- Rough-in ice machine potable water supply **1**. 3/8" push-in connection will be made at included shut-off valve then into solenoid.
- Remove access panel if necessary **2**.
- Connect the silicone tubing to the ice machine 3/4" drain barb **3**.
- Assemble the 3/4" barb x 3/4" FPT to the 3/4" MPT x 1" slip. Connect the other end of the silicone tubing to the 3/4" barb **4**.
- Connect the 1" slip fitting to the 1" stand pipe/drain **5**.

**Note:** Minimum 8" radius on silicone drain line. Drain line from the ice machine must have at least 1/4" per foot pitch (6,4 mm/0,3 m).

- Connect cooling water supply **6** and return **7**
- Apply Petrol-gel to barbed drain fitting **8**
- Replace access panel.

### Chassis drain plumbing - required

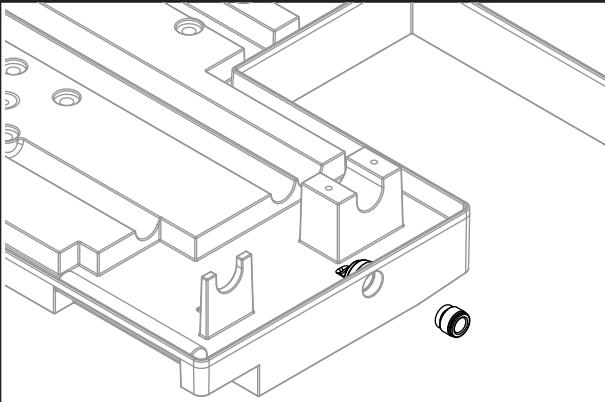

- Route 3/8" drain tubing through knockout in back of docking station and insert fully into John Guest fitting connection at the rear of the machine chassis. Route other end of 3/8" drain tubing to drain.
- Drain must slope 1/4" inch per foot (6 mm per 30,4 cm).

Connect docking assembly to ice machine.

**CAUTION**

- Plug must be accessible after final installation.
- E714 230/50/1 requires a 15A circuit (1.50 mm<sup>2</sup> wire).

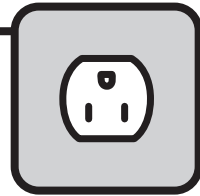

Air-cooled ice machines – follow steps 7.1 through 7.5.

**7.1 Ice transport tube**

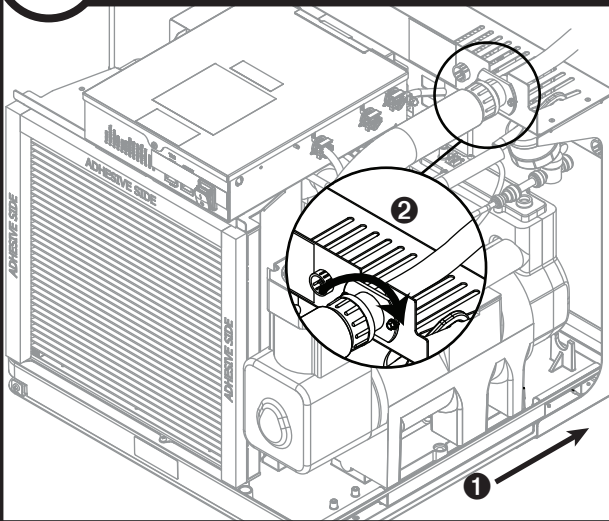

- Slide ice machine into docking assembly ensuring that drain tube is fully seated on barbed drain fitting **1**
- Insert ice transport tube all the way into coupling and tighten nut firmly **2**

**7.2 Shut-off valve, and potable water line options**

**If this is an undercounter installation:**

- Locate the shut-off valve *inside* the machine. Insert potable water line into shut-off valve.

**If machine will not be installed under-counter:**

- Insert potable water line into shut-off valve - locate the shut-off valve *outside* the machine.
- Insert outgoing line from shut-off valve into push-in connection of water solenoid.

**7.3 Power cord**

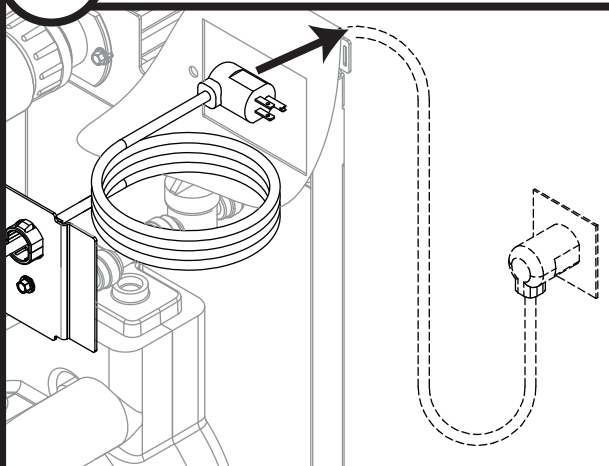

- Remove twist tie
- Carefully pass cord through opening and plug into wall outlet
- For E units, install a suitable plug

**7.4 Power cord**

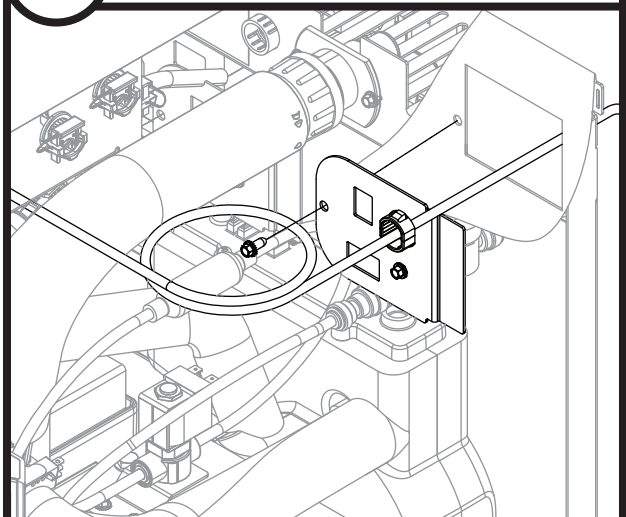

- Position plate into opening and secure with supplied screw

Water-cooled ice machines – follow steps 7.6 through 7.12.

### 7.5 TDS switch

- SERVICE
- MAINT/CLEAN
- LOW WATER
- TIME DELAY
- SLEEP CYCLE
- MAKING ICE
- LOW BIN
- POWER ON

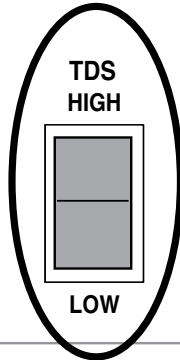

- Set the TDS switch on the electrical box:  
**HIGH:** for extended service life  
**LOW:** for low-scale water

### 7.6 Cooling lines

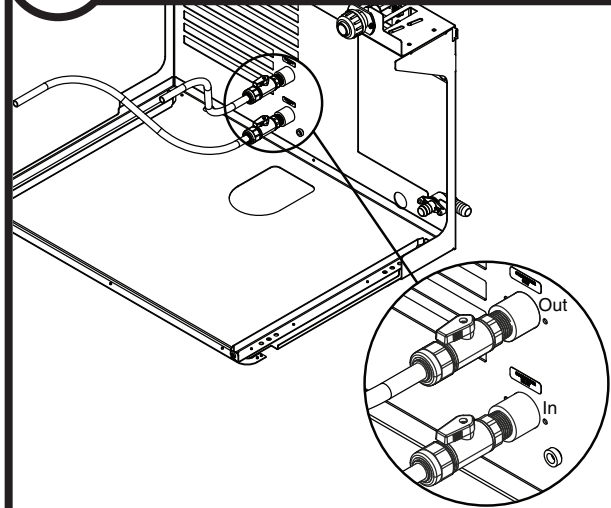

- Install ice machine cooling water lines to docking assembly

### 7.7 Ice transport tube

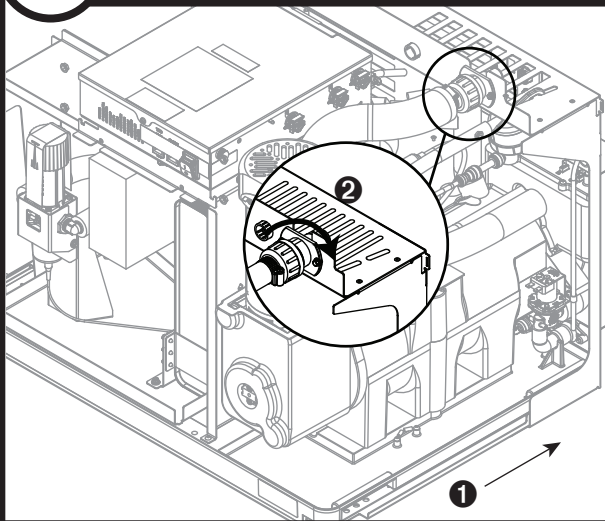

- Slide ice machine into docking assembly ensuring that drain tube is fully seated on barbed drain fitting ①
- Insert ice transport tube into coupling and tighten nut firmly ②

### 7.8 Shut-off valve, and potable water line options

#### If this is an undercounter installation:

- Locate the shut-off valve *inside* the machine. Insert potable water line into shut-off valve.

#### If machine will not be installed under-counter:

- Insert potable water line into shut-off valve - locate the shut-off valve *outside* the machine.
- Insert outgoing line from shut-off valve into push-in connection of water solenoid.

### 7.9

### Cooling lines and power

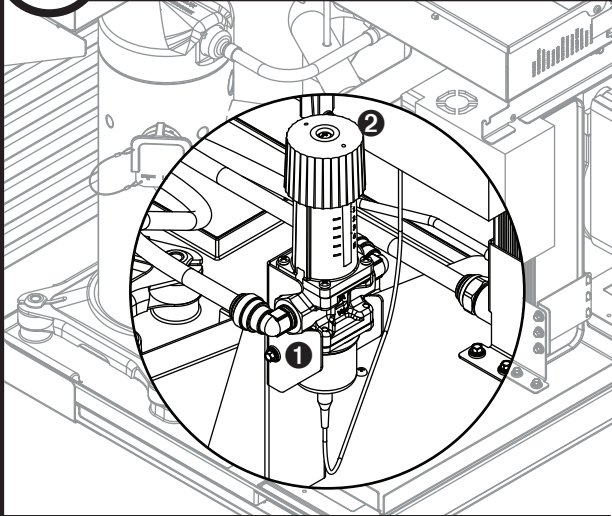

- Connect cooling water lines to ice machine (Water "Out" connects to water regulator.) ①
- Water valve is set at the factory. **DO NOT** remove seal or adjust water valve ②

### 7.10

### Power cord

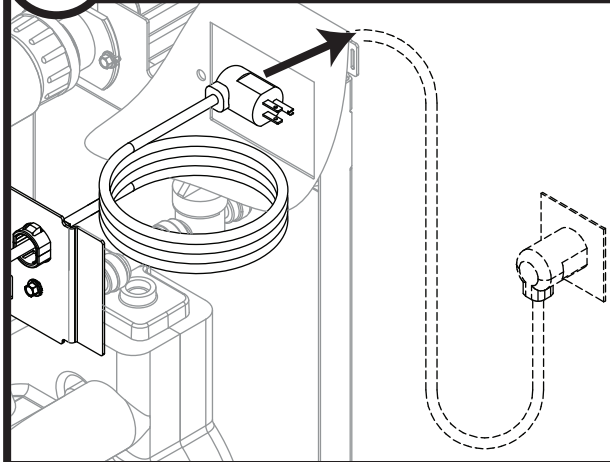

- Remove twist tie
- Carefully pass cord through opening and plug into wall outlet
- For E units, install a suitable plug

### 7.11

### Power cord

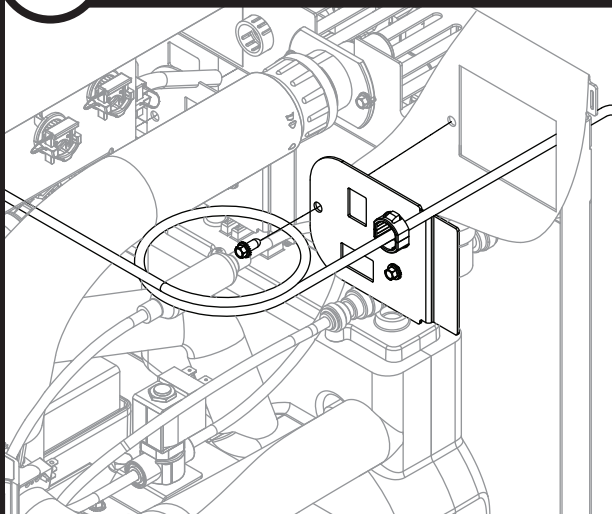

- Position plate into opening and secure with supplied screw

### 7.12

### TDS switch

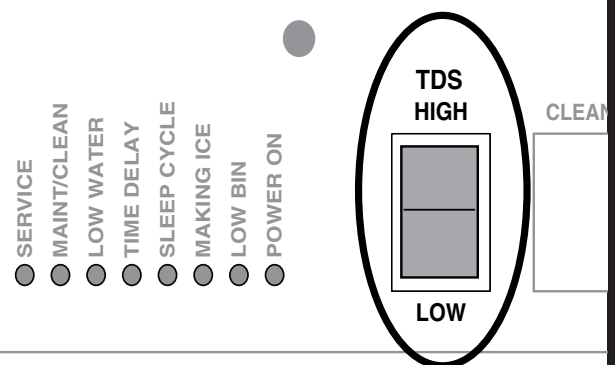

- Set the TDS switch on the electrical box:  
**HIGH:** for extended service life  
**LOW:** for low-scale water

Install front cover to ice machine.

Front cover

8

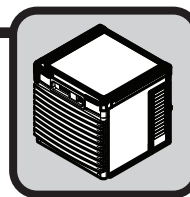

### 8.1 Install front cover

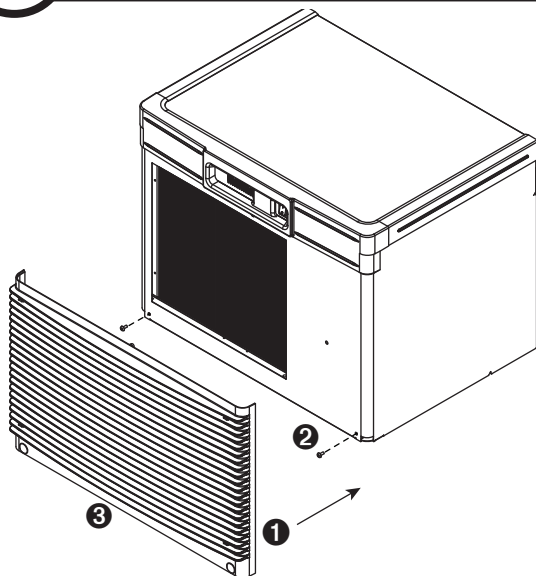

- Slide ice machine cover over machine ensuring that tabs on back of cover slip under louvers on back of docking assembly ①
- Insert and tighten two screws through cover and into docking assembly ②
- For air-cooled machines only, install plastic grill ③

#### NOTICE

**Ice machine MUST be sanitized prior to operation!**

Consult Operation and Service Manual provided with ice machine for sanitizing instructions.

**Ice machine startup procedure.****9.1 Ice machine start up procedure**

The start-up procedure below is intended to ensure that ice machine is operating properly after installation has been made. Check each item listed and call factory immediately for assistance if you experience problems with unit.

** NOTICE!**

- Ice machine **MUST** be sanitized prior to operation!
- Consult Operation and Service Manual provided with ice machine for sanitizing instructions.

**Before turning on power**

1. Sanitize ice bin.
2. Turn on water to ice machine and check for leaks.

**After turning on power**

1. Turn on power switch and immediately press Clean switch to sanitize ice machine. At beginning of sanitizing process, ice machine will purge all water. Check internal and external drain connections for leaks.
2. After sanitizing process, ice machine will start. Confirm that gearmotor, fan motor and compressor start immediately.
3. Check that ice begins to enter dispenser bin area within approximately 10 minutes.

## Long tube run recommendations

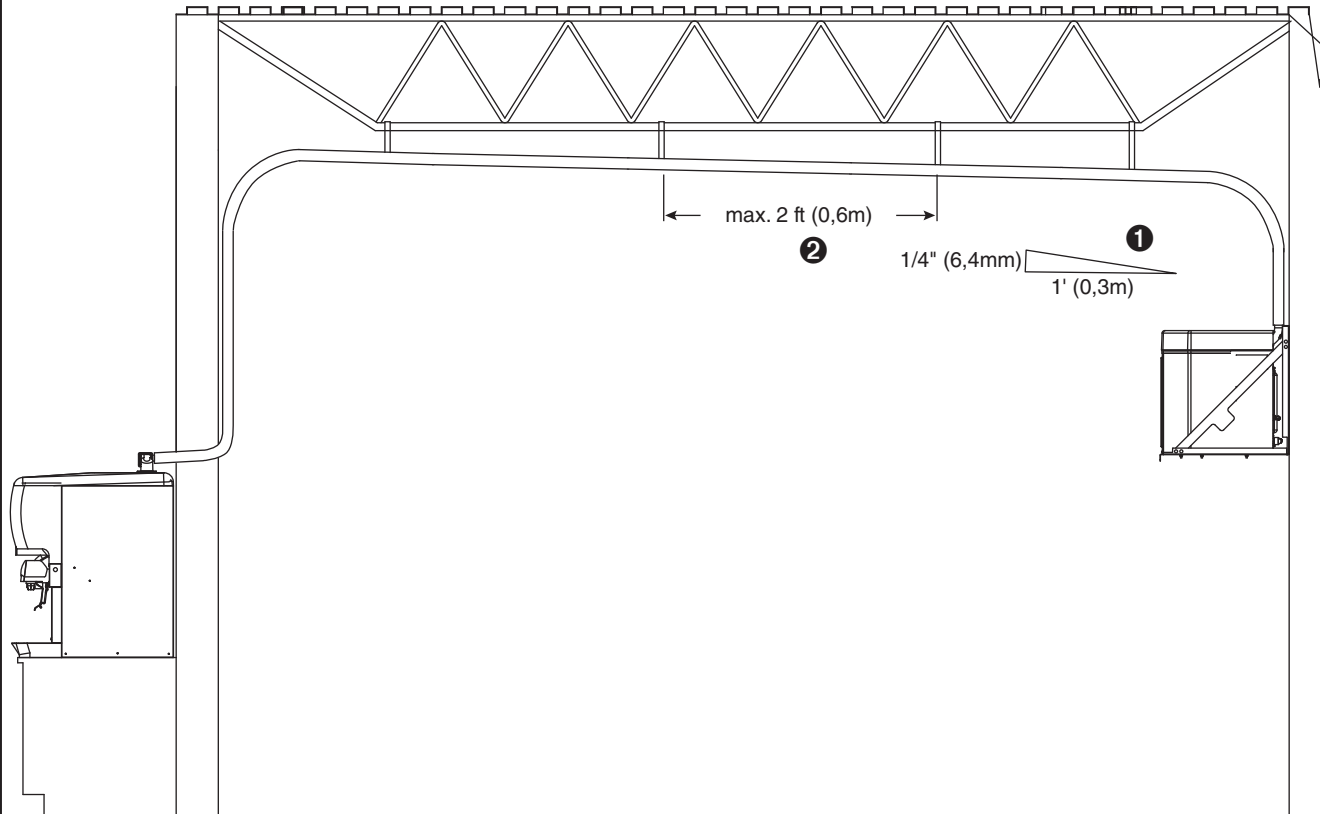

- Pitch ice transport tube to allow melt water to drain towards ice machine ①
- Secure insulated ice transport tube at least every 2 ft (0,6 m) to prevent dips or traps ②

Maestro, Vision, Ice Manager, Horizon, Horizon Elite are trademarks of Follett Products, LLC.  
Chewblet, RIDE, and Follett are registered trademarks of Follett Products, LLC.