

Horizon Elite™ Ice Machine Installation Instructions to Ice Storage Bin Top-mount Applications

D714, E714, C1014, C1414

Order parts online
www.follettice.com

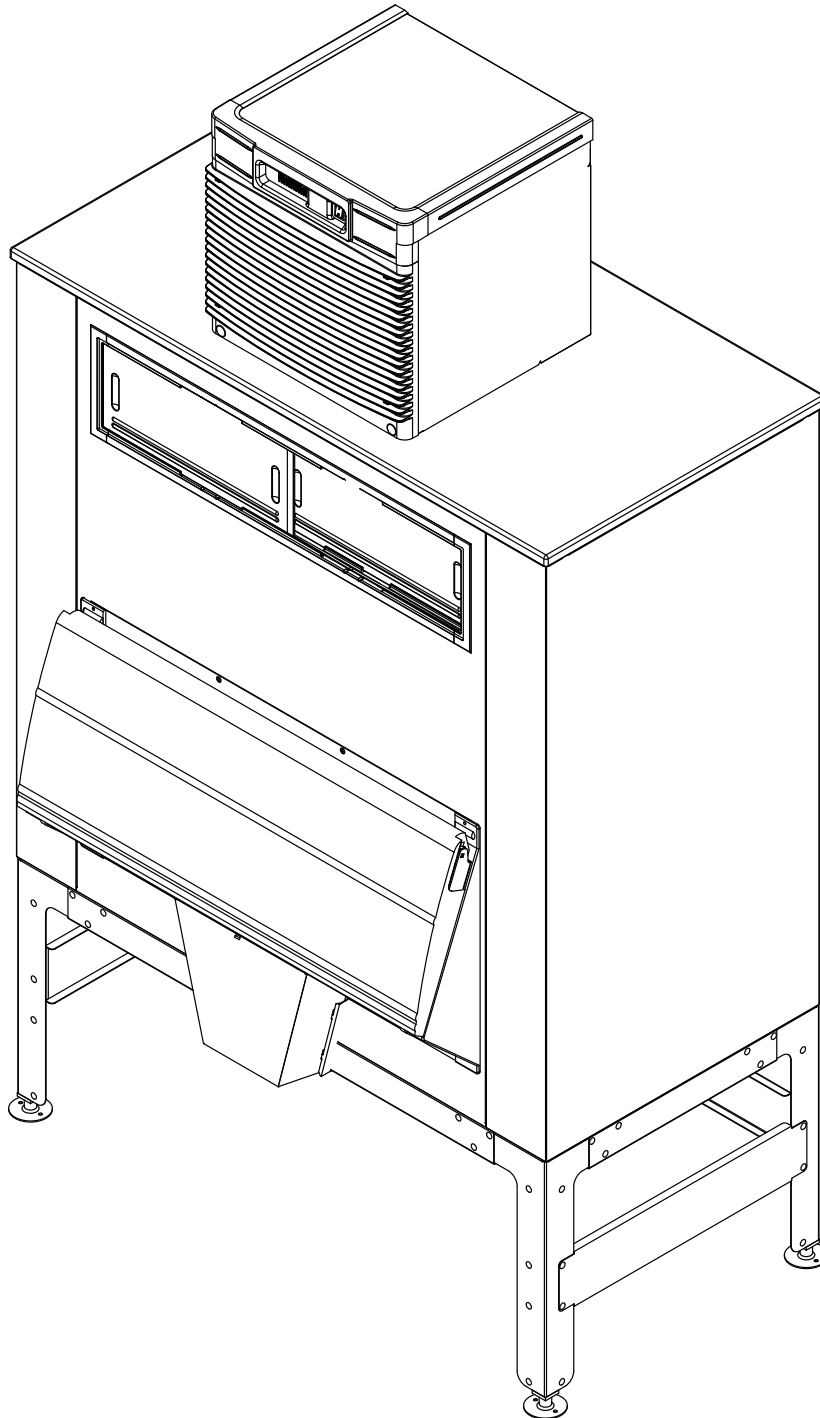
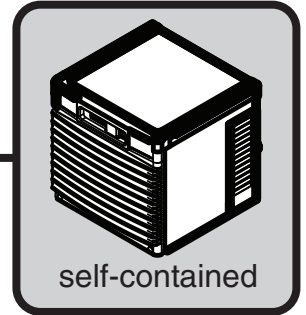

 **CAUTION!**

- This appliance should be connected by a qualified person in accordance with applicable codes.
- If the supply cord is damaged, it must be replaced by the manufacturer, its service agent or similarly qualified persons in order to avoid a hazard.
- Connect to potable water supply only.
- This appliance can be used by children aged 8 years and above and persons with reduced physical, sensory, or mental capabilities, or lack of experience and knowledge if they have been given supervision or instruction concerning use of the appliance in a safe way and understand the hazards involved. Children should be supervised to ensure that they do not play with the appliance.
- This appliance is intended to be used for household and similar applications such as staff kitchen areas in shops, offices and other working environments; farm houses and by clients in hotels, motels and other residential type environments; bed and breakfast type environments; catering and similar non-retail applications.
- **WARNING!** To avoid a hazard due to instability of the appliance, it must be fixed in accordance with the instructions.

Contents

Unpack	4
Unpack Ice Machine	4
Site Preparation	5
Installation site requirements	5
Docking Assembly Installation	6
External Connections	7
Ice Transport Tube Installation	7
Air-cooled ice machines only	8
Water-cooled ice machines only	8
Internal Connections	10
Ice transport tube	10
Potable water lines	10
Power cord	10
Power cord	10
TDS switch	11
Cooling Lines	11
Ice transport tube	11
Potable Water Line	11
Cooling lines and power	12
Power cord	12
Plate	12
TDS switch	12
Front Cover	13
Ice machine start up procedure	13
Before turning on power	13
After turning on power	13

1. Unpack

Carefully unpack and inspect the contents of your Follett ice machine.

1.1 Unpack Ice Machine

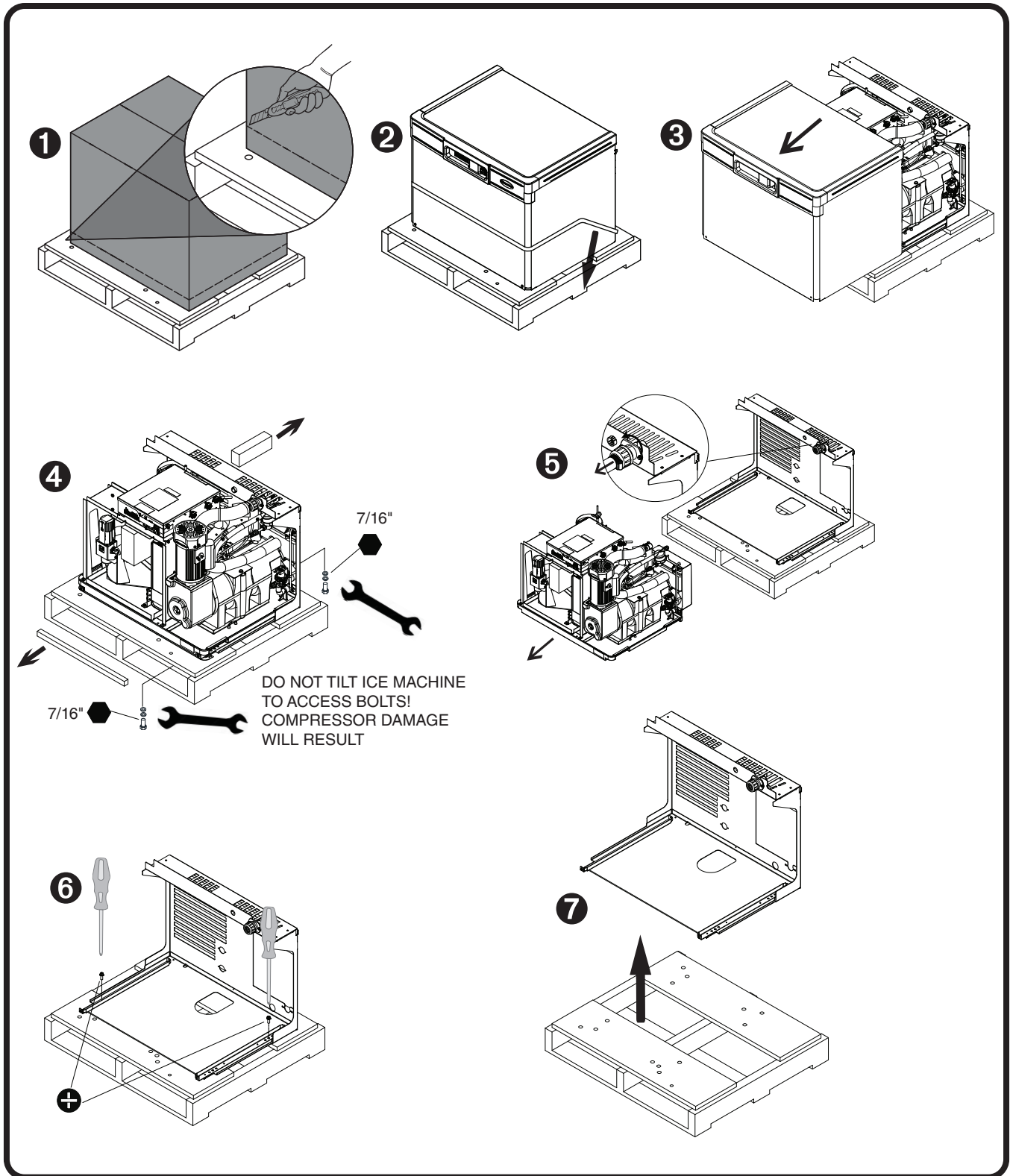

2. Site Preparation

Provide drainage, potable water supply and electrical power to within 6 feet (2m) of ice machine in accordance with local and national codes. Outdoor installation is not recommended and will void warranty.

2.1 Installation site requirements

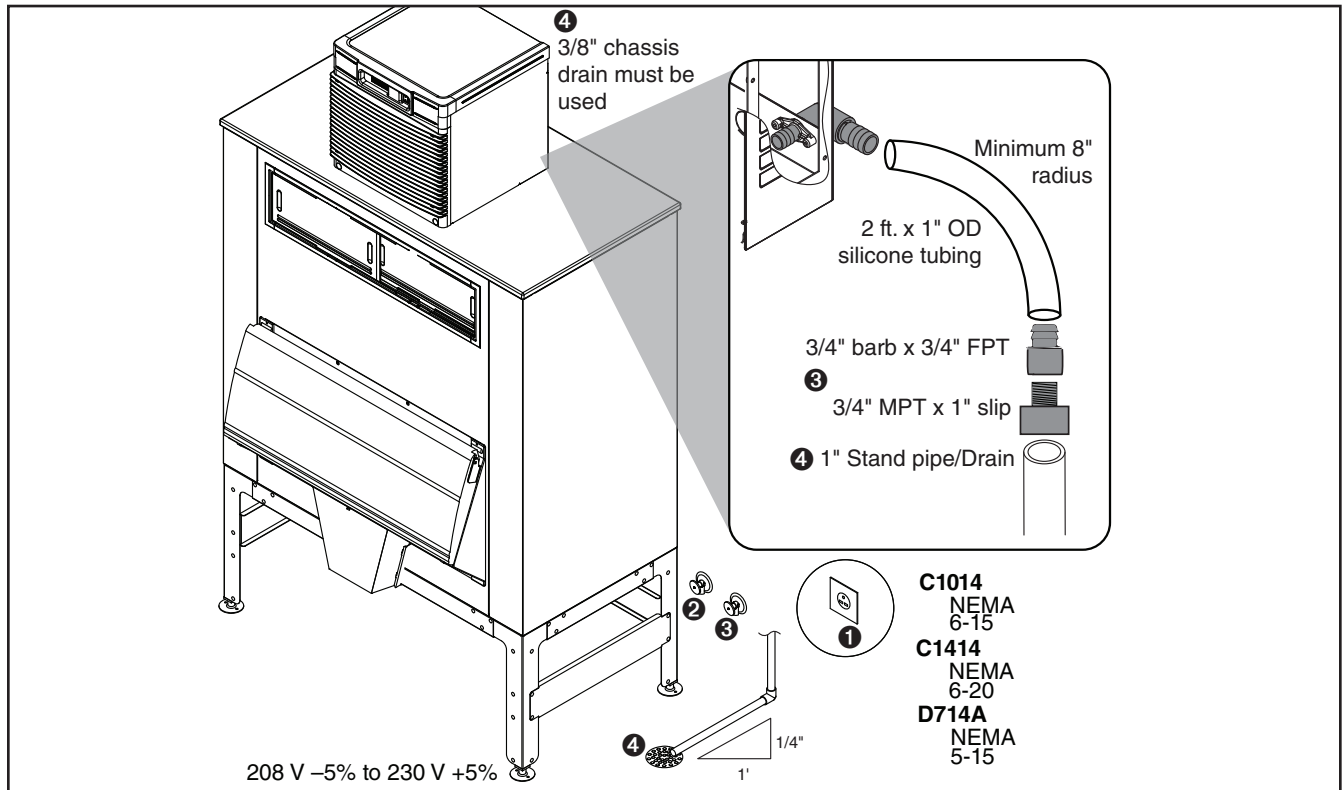

Electrical ①

⚠ WARNING!

- This appliance should be permanently connected by a qualified person in accordance with applicable codes.
- If the supply cord is damaged, it must be replaced by the manufacturer, its service agent or similarly qualified persons in order to avoid a hazard.

C1014 and C1414 208-230/60
Requires a 15A dedicated circuit.

D714 115/60 (Requires a 15A circuit)
E714 230/50[‡]

[‡] E714 requires 15A dedicated circuit 1.50 mm² wire. Plug must be provided by end user & must conform to standard EN 60 335-2-24 of the end destination.

Potable Water Supply ② (3/8" push-in internal connection, 3/8" OD tubing required)

10 psi to 70 psi (69 kpa to 483 kpa)

45 F to 90 F (7 C to 32 C)

- This equipment is to be installed with adequate backflow protection to comply with applicable federal, state, and local codes

Condenser water supply for water-cooled systems ③ (1/4" FPT inlet, 1/4" FPT outlet)

10 psi min.; 150 psi max. (69 kpa min.; 1034 kpa max.)

20 F to 90 F (-7 C to 32 C)

1.5 gallons (5.68 liters) per minute

Drains: ④ 3/4" Barb for silicone drain, 3/8" push-to-connect for chassis drain

Minimum 8" radius on silicone drain line. The drain line from the ice machine must have at least 1/4" per foot (6,4 mm/0,3 m) pitch

3. Docking Assembly Installation

WARNING!

- Prior to installing the docking assembly, ensure that the drain fitting is oriented (right or left) correctly for your installation. An optional straight drain fitting is also supplied. You may need to remove the back panel of the docking assembly in order to re-orient or change the drain fitting. Replace back panel prior to mounting the docking assembly.
- Docking station must be secured in accordance with these instructions to ensure ice machine stability.
- Ventilation openings in the docking station should be clear of obstruction. Failure to do so could result in damage to equipment.
- Plug must be accessible after final installation.

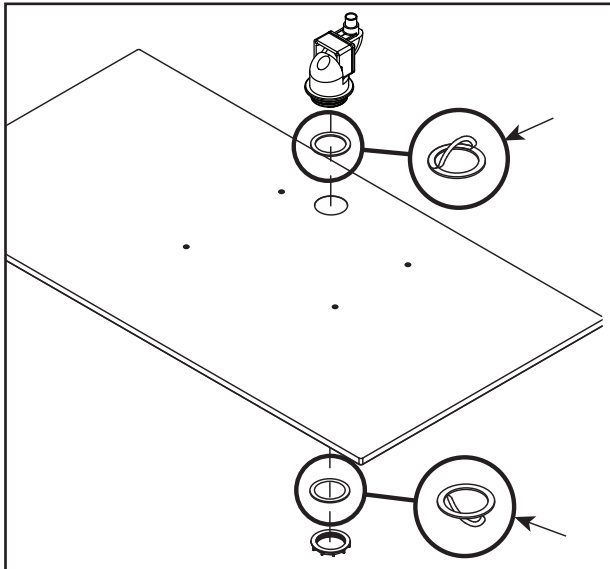

- Remove protective tape from gaskets.

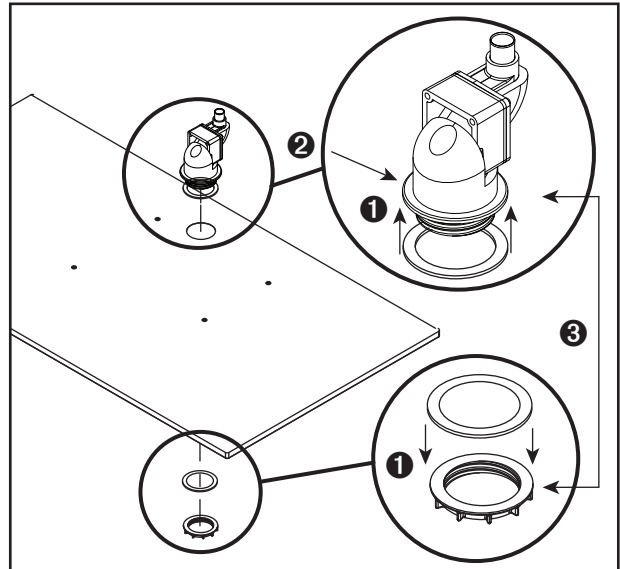

- Apply gaskets **1**.
- Install shuttle actuator **2** through dispenser top and secure with locking nut **3**.

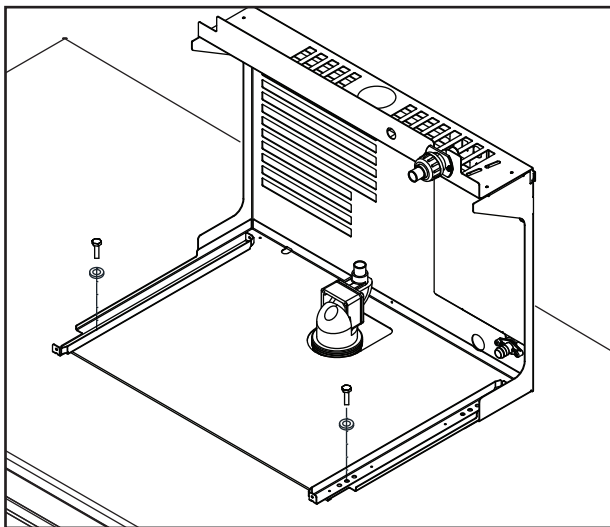

- Mount docking assembly using two screws provided.

4. External Connections

4.1 Ice Transport Tube Installation

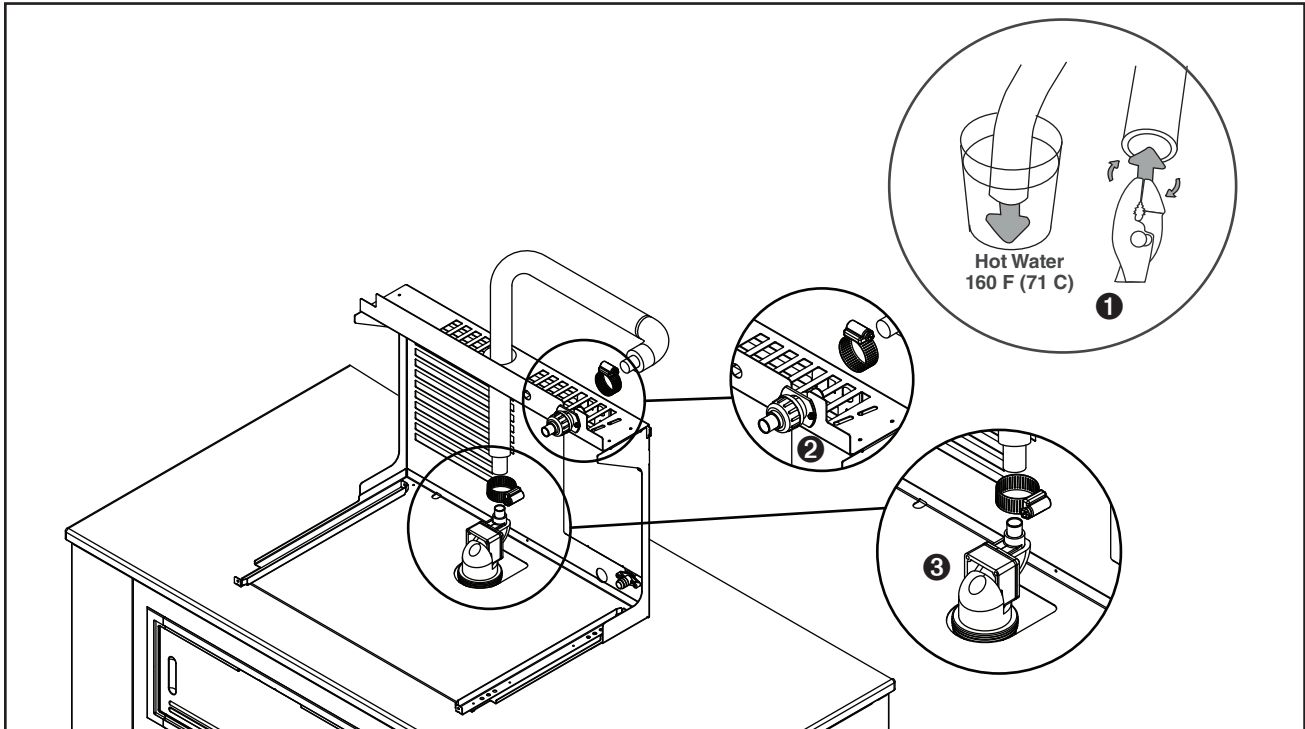

- Install supplied ice transport tube insulation.
- Heat end of transport tube in cup of 160 F (71 C) hot water to soften and spread with pliers ❶ before making connection to ease assembly.
- Connect ice transport tube to coupling on docking station ❷.
- Connect ice transport tube to shuttle actuator ❸.

4.2 Air-cooled ice machines only

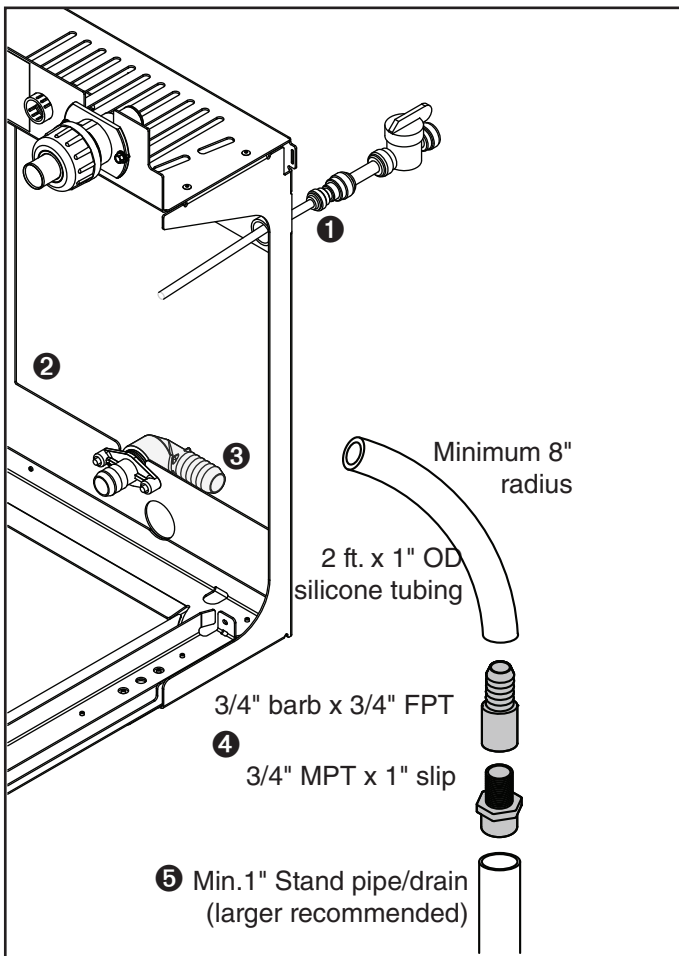

- Rough-in ice machine potable water supply ①. 3/8" push-in connection will be made at shut-off valve inside machine
- Remove access panel if necessary ②.
- Connect the silicone tubing to the ice machine 3/4" drain barb ③.
- Assemble the 3/4" barb x 3/4" FPT to the 3/4" MPT x 1" slip. Connect the other end of the silicone tubing to the 3/4" barb ④.
- Connect the 1" slip fitting to the 1" stand pipe/drain ⑤.

Note: Minimum 8" radius on silicone drain line. Drain line from the ice machine must have at least 1/4" per foot pitch (6,4 mm/0,3 m).

- Apply Petrol-gel to barbed drain fitting ⑥
- Replace access panel.

4.3 Water-cooled ice machines only

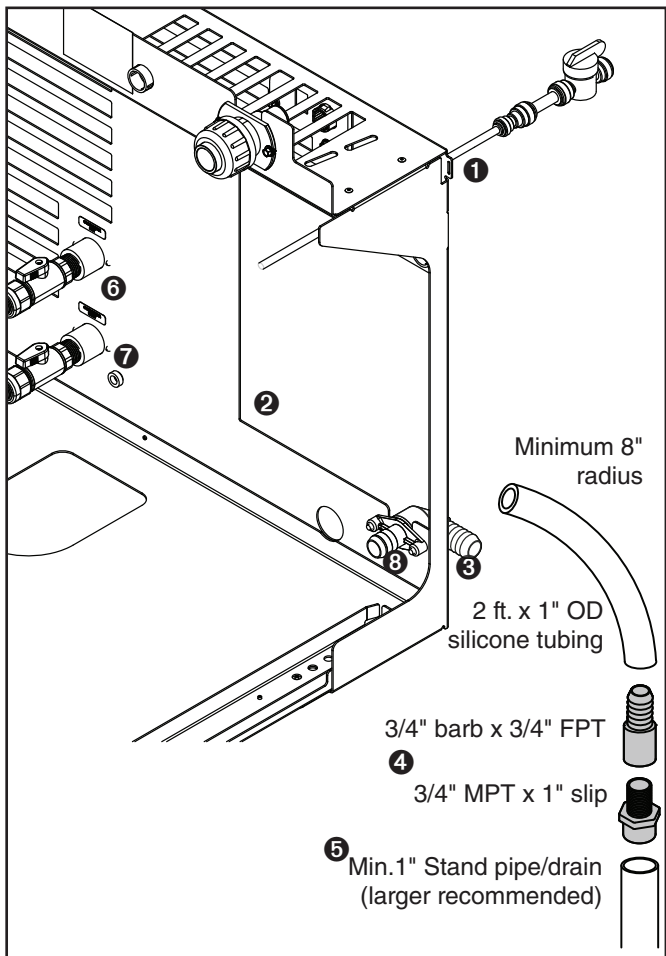

- Rough-in ice machine potable water supply ①. 3/8" push-in connection will be made at shut-off valve inside machine
- Remove access panel if necessary ②.
- Connect the silicone tubing to the ice machine 3/4" drain barb ③.
- Assemble the 3/4" barb x 3/4" FPT to the 3/4" MPT x 1" slip. Connect the other end of the silicone tubing to the 3/4" barb ④.
- Connect the 1" slip fitting to the 1" stand pipe/drain ⑤.

Note: Minimum 8" radius on silicone drain line. Drain line from the ice machine must have at least 1/4" per foot pitch (6,4 mm/0,3 m).

- Connect cooling water supply ⑥ and return ⑦
- Apply Petrol-gel to barbed drain fitting ⑧
- Replace access panel.

Chassis drain plumbing - required

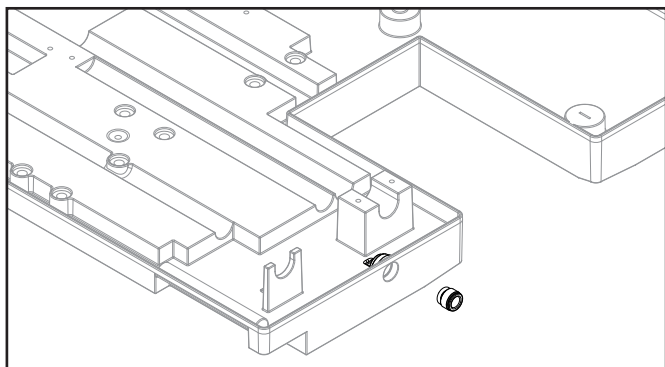

- Route 3/8" drain tubing through knockout in back of docking station and insert fully into John Guest fitting connection at the rear of the machine chassis. Route other end of 3/8" drain tubing to drain.
- Drain must slope 1/4" inch per foot (6 mm per 30,4 cm).

5. Internal Connections

Air-cooled ice machines – follow steps 5.1 and 5.5.

Water-cooled ice machines – follow steps 5.6 through 5.12.

5.1 Ice transport tube

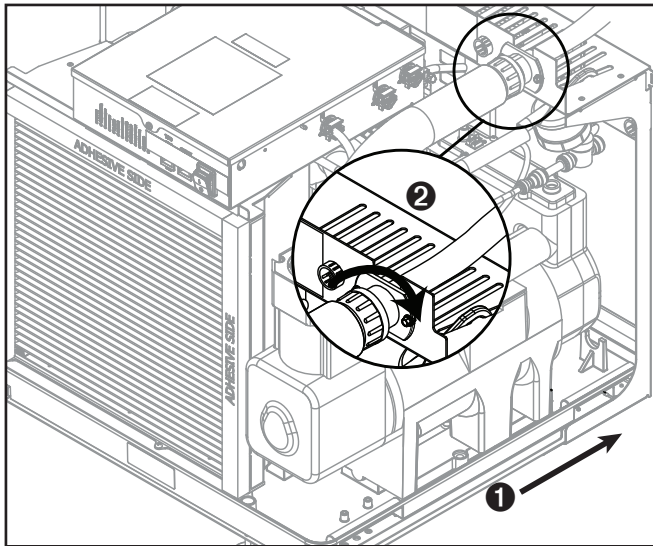

- Slide ice machine into docking assembly ensuring that drain tube is fully seated on barbed drain fitting ①.
- Insert ice transport tube all the way into coupling and tighten nut firmly ②.

5.2 Potable water lines

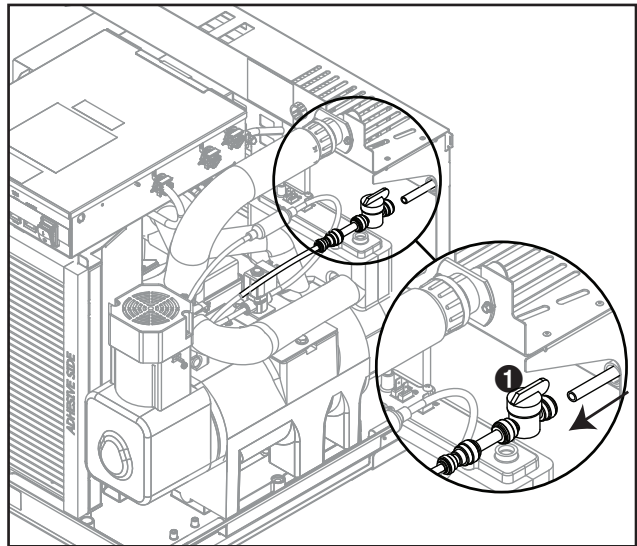

- Insert potable water line into valve ①.

5.3 Power cord

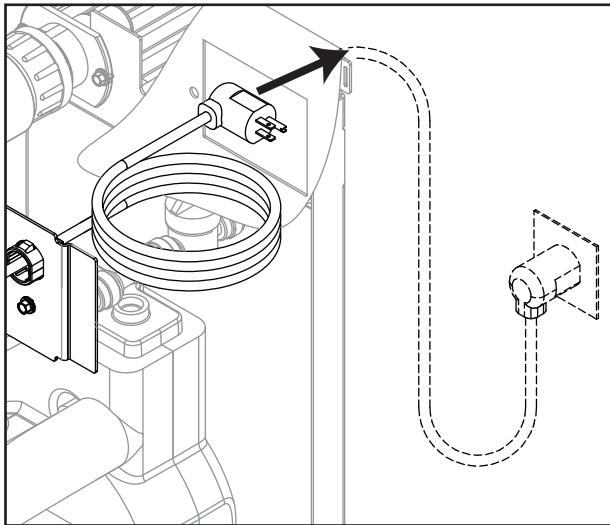

- Remove twist tie.
- Carefully pass plug through opening and plug into wall outlet.
- For E units, install a suitable plug.

5.4 Power cord

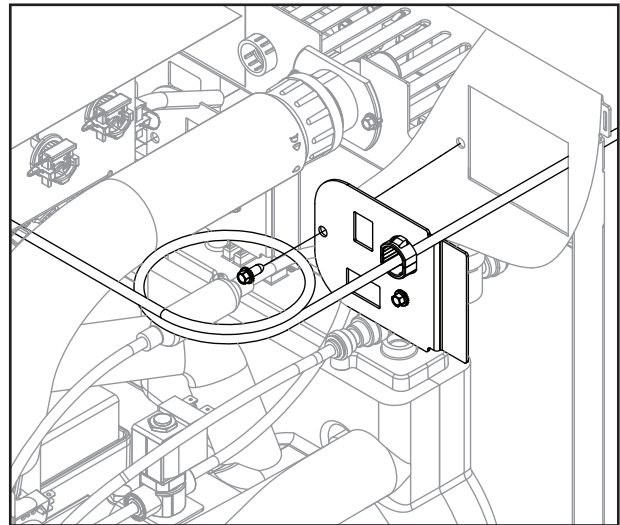

- Position plate into opening and secure with supplied screw.

WARNING!

Plate must be securely installed to ensure proper equipment ground.

5.5 TDS switch

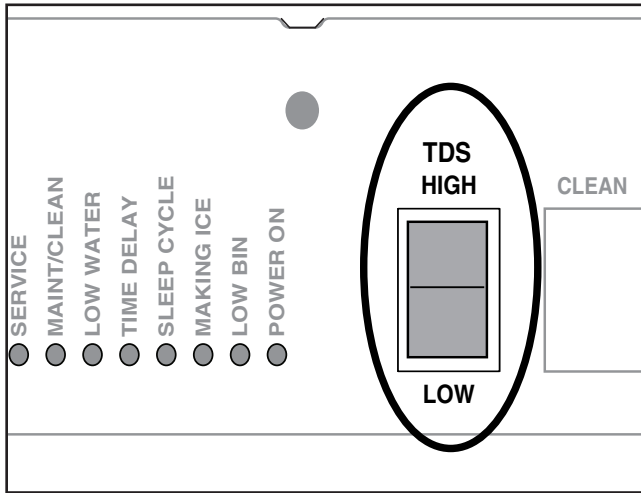

- Set the TDS switch on the electrical box.
 - **HIGH:** for extended service life
 - **LOW:** for low-scale water

5.6 Cooling Lines

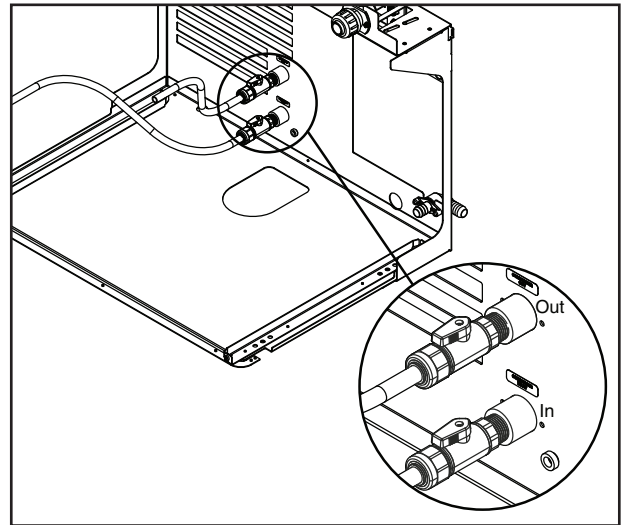

- Install ice machine cooling water lines to docking assembly.

5.7 Ice transport tube

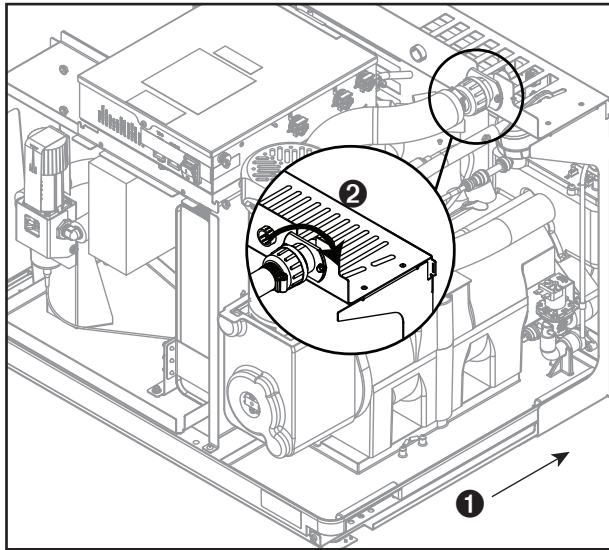

- Slide ice machine into docking assembly ensuring that drain tube is fully seated on barbed drain fitting ①.
- Insert ice transport tube into coupling and tighten nut firmly ②.

5.8 Potable Water Line

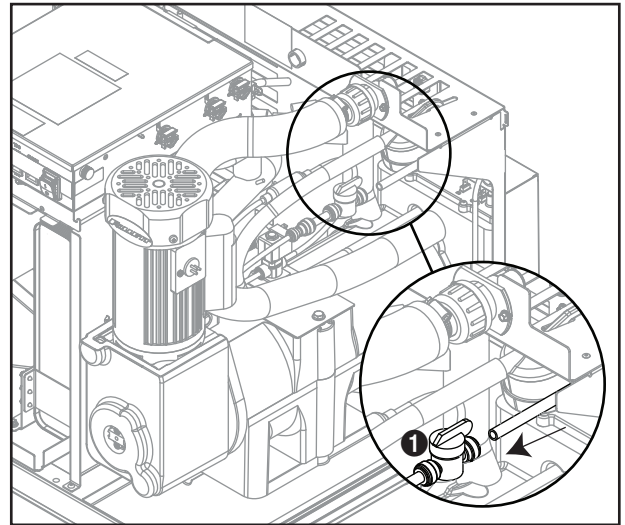

- Insert potable water line into valve ①.

5.9 Cooling lines and power

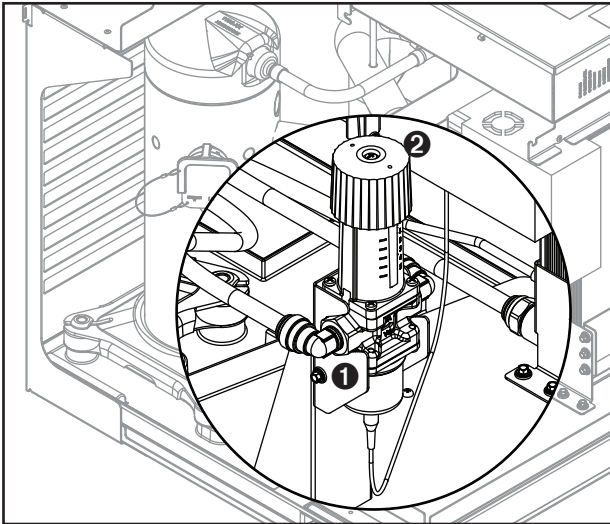

- Connect cooling water lines to ice machine **1**. (Water "Out" connects to water regulator.)
- Water valve is set at the factory. **DO NOT** remove seal or adjust water valve **2**.

5.11 Plate

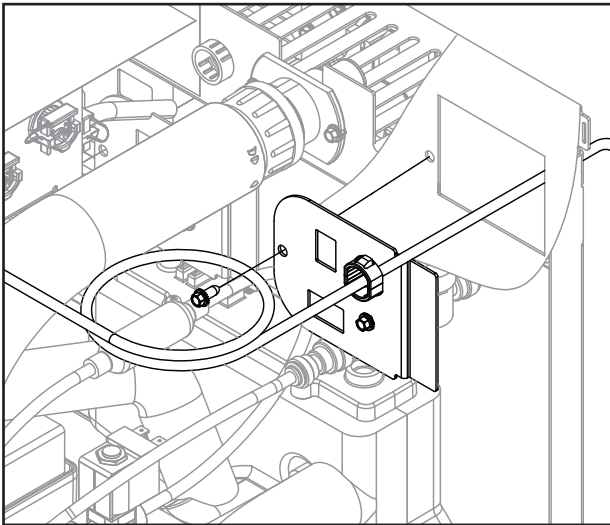

- Position plate into opening and secure with supplied screw.

WARNING!

Plate must be securely installed to ensure proper equipment ground.

5.10 Power cord

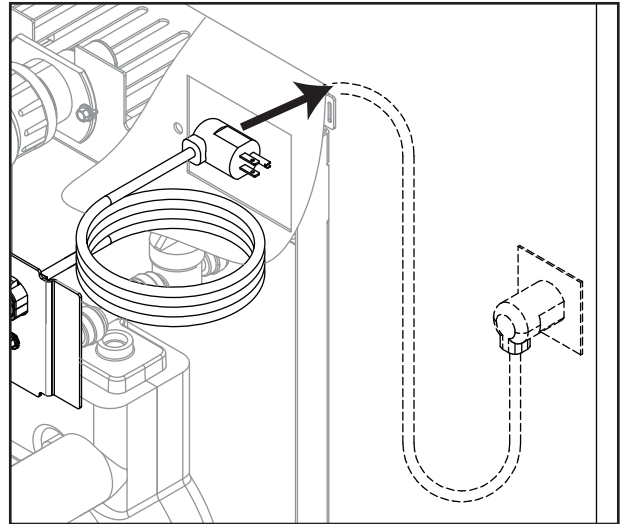

- Remove twist tie.
- Carefully pass plug through opening and plug into wall outlet.
- For E units, install a suitable plug.

5.12 TDS switch

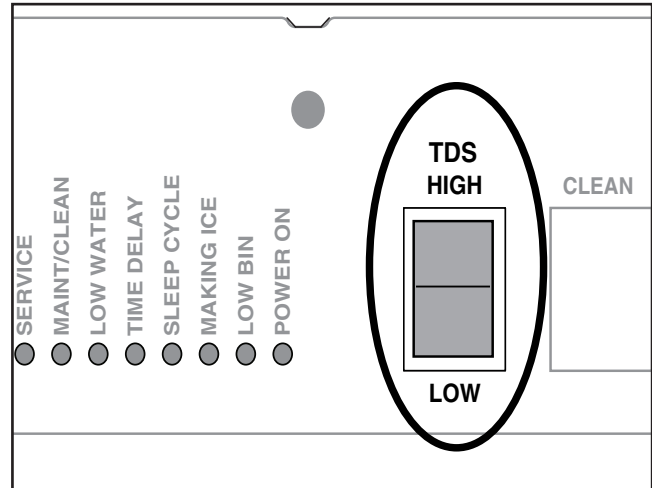

- Set the TDS switch on the electrical box.
 - **HIGH:** for extended service life
 - **LOW:** for low-scale water

6. Front Cover

Install front cover to ice machine.

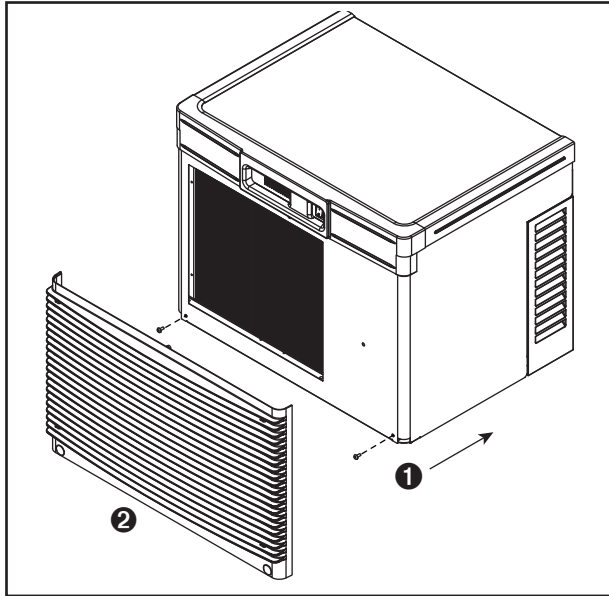

- Slide ice machine cover over machine, ensuring that tabs on back of cover slip under louvers on back of docking assembly ①, then tighten two screws through cover.
- Place front cover on machine ②.

7. Ice machine start up procedure

The start-up procedure below is intended to ensure that ice machine is operating properly after installation has been made. Check each item listed and call factory immediately for assistance if you experience problems with unit.

NOTICE!

- Ice machine **MUST** be sanitized prior to operation!
- Consult Operation and Service Manual provided with ice machine for sanitizing instructions.

7.1 Before turning on power

1. Sanitize ice bin.
2. Turn on water to ice machine and check for leaks.

7.2 After turning on power

1. Turn on power switch and immediately press Clean switch to sanitize ice machine. At beginning of sanitizing process, ice machine will purge all water. Check internal and external drain connections for leaks.
2. After sanitizing process, ice machine will start. Confirm that gearmotor, fan motor and compressor start immediately.
3. Check that ice begins to enter dispenser bin area within approximately 10 minutes.

Maestro, Vision, Ice Manager, Horizon, Horizon Elite are trademarks of Follett Products, LLC.
Chewblet, RIDE, Follett are registered trademarks of Follett Products, LLC.

FOLLETT[®] 801 Church Lane • Easton, PA 18040, USA
Toll free (877) 612-5086 • +1 (610) 252-7301
www.follettice.com

01113307R07
© Follett Products, LLC 2/26