

Horizon Elite™ C1014A/C1414A/W Ice Machines (Self-contained) R290, 208-230V 60 Hz

User Guide

Please visit www.follettice.com/technicaldocuments for the Operation and Service manual for your unit.

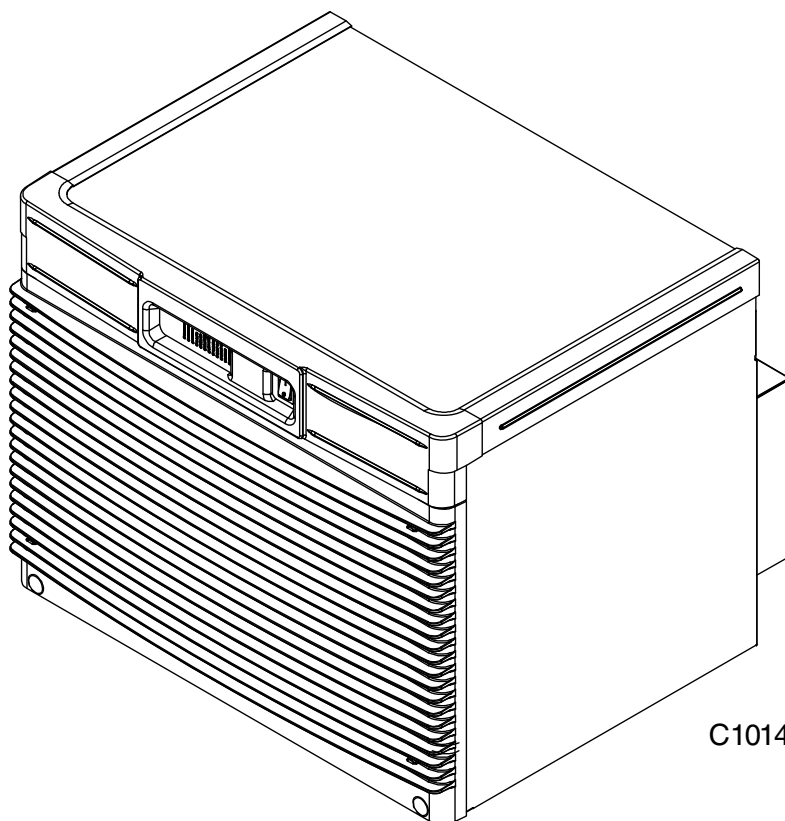

C1014A/C1414A/W

Welcome to Follett

Follett equipment enjoys a well-deserved reputation for excellent performance, long-term reliability and outstanding after-the-sale support. To ensure that this equipment delivers that same degree of service, review this guide carefully before you begin your installation.

Should you need technical help, please call our Technical Service group at (877) 612-5086 or (610) 252-7301.

Please have your model number, serial number and complete and detailed explanation of the problem when contacting Technical Service.

Getting Started

After uncrating and removing all packing material, inspect the equipment for concealed shipping damage. All freight is to be inspected upon delivery. If visible signs of damage exist, please refuse delivery or sign your delivery receipt "damaged." Follett Customer Service must be notified within 48 hours. Wherever possible, please include detailed photos of the damage with the original packaging so that we may start the freight claim process.



WARNING! Risk of fire or explosion. Flammable refrigerant used. Follow handling instruction carefully. To be repaired only by trained service Personnel.



WARNING! Do not puncture Refrigerant Tubing. Do not use this product with flammable gases or flammable solvents.



WARNING! Do not store flammable gases, flammable liquids or flammable solids in these units. Do not use FLAME to check for gas leak.



WARNING! Do not under any circumstances try to modify or repair valves, regulator, connectors, controls or any other appliance. Doing so creates the risk of a gas leak.



WARNING! Keep ventilaton openings clear of obstruction.



WARNING! Do not damage the refrigerant circuit.



WARNING! Connect to potable water supply only.

WARNING!

Installation

- Read this manual thoroughly before operating, installing or performing maintenance on the equipment. Failure to follow instructions in this manual can cause property damage, personal injury, or death.
- The ice machine contains R290 (propane) refrigerant. R290 (propane) is flammable in concentrations of air between approximately 2.1% and 9.5% by volume. R290 (propane) may burn if exposed to a heat source above 470 °C.
- Because R290 is highly flammable, a combustible gas leak detector is required when servicing R290 systems.
- This equipment contains high-voltage electricity and refrigerant charge. Installation and Service repairs are to be performed by properly trained technicians aware of the dangers of dealing with high voltage electricity and refrigerant under pressure. The technician must also be certified in proper refrigerant handling and servicing procedures.
- All lockout and tag out procedures must be followed when working on this equipment.
- A qualified person shall provide a readily accessible disconnect device incorporated into the fixed wiring.
- This appliance should be installed by a qualified person in accordance with application codes.
- If the supply cord is damaged, it must be replaced by the manufacturer, its service agent or similarly qualified persons in order to avoid a hazard.
- Do not tilt unit further than 30° off vertical during uncrating or installation.
- This appliance is designed for commercial use.
- This equipment is intended for indoor use only. Do not install or operate this equipment in outdoor areas.
- Warranty does not cover exterior or outside installations.
- To avoid a hazard due to instability of the appliance, it must be fixed in accordance with the instructions.
- Maintain all minimum clearances. DO NOT obstruct vents or openings.
- This appliance is not suitable for installation in an area where a water jet could be used.
- Connect to potable water supply only.
- Follett recommends a Follett water filter system be installed in the ice machine inlet water line (standard capacity, high capacity, carbonless high capacity).
- We reserve the right to make product improvements at any time. Specifications and design are subject to change without notice.

Usage

- Read this manual thoroughly before operating, installing or performing maintenance on the equipment. Failure to follow instructions in this manual can cause property damage, personal injury, or death.
- User maintenance should not be done by children.
- This appliance is not intended for use by persons (including children) with reduced physical, sensory or mental capabilities, or lack of experience and knowledge, unless they have been given supervision or instruction concerning use of the appliance by a person responsible for their safety.
- Children should be supervised to ensure that they do not play with the appliance.
- If the supply cord is damaged, it must be replaced by the manufacturer, its service agent or similarly qualified persons in order to avoid a hazard.
- Routine adjustments and maintenance procedures outlined in this manual are not covered by the warranty.

- Maintain all minimum clearances. DO NOT obstruct vents or openings.
- This appliance must not be cleaned by a water jet.
- Connect to potable water supply only.
- Ice is food. Follow recommended cleaning instructions to maintain cleanliness of delivered ice.
- Ice is slippery. Maintain counters and floors around dispenser in a clean and ice-free condition.
- We reserve the right to make product improvements at any time. Specifications and design are subject to change without notice.

Service

- Read this manual thoroughly before operating, installing or performing maintenance on the equipment. Failure to follow instructions in this manual can cause property damage, personal injury, or death.
- Review Installation section.
- This equipment contains high-voltage electricity and refrigerant charge. Installation and Service repairs are to be performed by properly trained technicians aware of the dangers of dealing with high voltage electricity and refrigerant under pressure. The technician must also be certified in proper refrigerant handling and servicing procedures.
- To reduce risk of shock, disconnect power before servicing.
- When servicing this equipment, be sure to lock the circuit breaker, and display an in-service notice.
- Repair on R290 systems must always be done in a well-ventilated area.
- If the supply cord is damaged, it must be replaced by the manufacturer, its service agent or similarly qualified persons in order to avoid a hazard.
- Only use parts recommended or provided by the manufacturer. Use of unapproved parts can be dangerous due to design requirements to safely use R290 (propane).
- Routine adjustments and maintenance procedures outlined in this manual are not covered by the warranty.
- Maintain all minimum clearances. DO NOT obstruct vents or openings.
- This appliance must not be cleaned by a water jet.
- Connect to potable water supply only.
- We reserve the right to make product improvements at any time. Specifications and design are subject to change without notice.

Decommissioning and Dismantling

- Read this manual thoroughly before operating, installing or performing maintenance on the equipment. Failure to follow instructions in this manual can cause property damage, personal injury, or death.
- Decommissioning and Dismantling are to be performed by properly trained technicians aware of the dangers of dealing with high voltage electricity and refrigerant under pressure. The technician must also be certified in proper refrigerant handling procedures for R290 (flammable) refrigerant.
- Review Installation section.
- Ensure area is being well-ventilated before Decommissioning and Dismantling of equipment using R290 (flammable) refrigerant.
- When servicing this equipment, be sure to lock the circuit breaker, and display an in-service notice.
- To reduce risk of shock, disconnect power before servicing.
- Utilize and maintain good safety practices and follow all applicable local, state, and federal regulations for proper decommissioning and disposal of the equipment.
- Ensure all personal protective equipment is used during the entire process.
- Ensure all necessary tools and equipment are available, including recovery equipment and cylinders.
- All containers used for recovery must have proper labelling to ensure they can be used for R290 (flammable) refrigerant.
- Before starting recovery, place refrigerants on scales. Do not overfill containers more than 80% of volume, and do not exceed working pressure of the container.
- Before using a recovery machine, ensure that it is in satisfactory working order and that the electrical components are properly sealed to prevent any type of ignition.
- Recovered refrigerant shall not be added or used in another refrigerating system or mixed into another container.
- If the compressor or compressor oils are removed, ensure it has been removed to an acceptable level so that flammable refrigerant does not remain in the lubricant.

Disposal

- Follow all applicable local, state, and federal regulations for proper disposal of the equipment.
- All recovered refrigerant must be returned to an appropriate refrigerant supplier for proper disposal.
- DO NOT dispose of your appliance with household waste.

Specifications

Electrical

Each ice machine requires its own separate circuit with electrical disconnect within 10 ft (3 m).
Equipment ground required.

Standard electrical:

- C1014: 208-230/60/1 (6 ft (2 m) NEMA 6-15 cord and plug provided) requires dedicated 15A circuit
- C1414: 208-230/60/1 (6 ft (2 m) NEMA 6-20 cord and plug provided) requires dedicated 20A circuit
- Amperage: C1014A: 10A, C1414A: 14A, C1414W: 12.5A

Plumbing

WARNING

This equipment to be installed with adequate backflow protection to comply with applicable federal, state, and local codes.

- 3/8" OD push-in water inlet - 3/8" OD tubing required
- 3/4" MPT flush drain, 3/8" chassis drain
- 1/2" FPT condenser inlet (water-cooled condenser only)
- 1/2" FPT condenser drain (water-cooled condenser only)

Notes:

- Water shut-off recommended within 10 feet (3 m).
- Follett does not recommend the use of water softeners or bowl scale inhibitors.
- The potable water total dissolved solids (TDS) content must be greater than 10 ppm for the water control system to function properly. If using reverse osmosis water filtration system, ensure TDS level is greater than 10 ppm.

Flush drain plumbing

- 3/4" MPT flush drain connection at the rear of the machine.
- Drain must slope 1/4" per foot (6 mm per 30,4 cm).
- Drain line should not be shared with any other piece of equipment.
- Drain line cannot be reduced to a size smaller than 1".
- Drain should be piped without a vent.

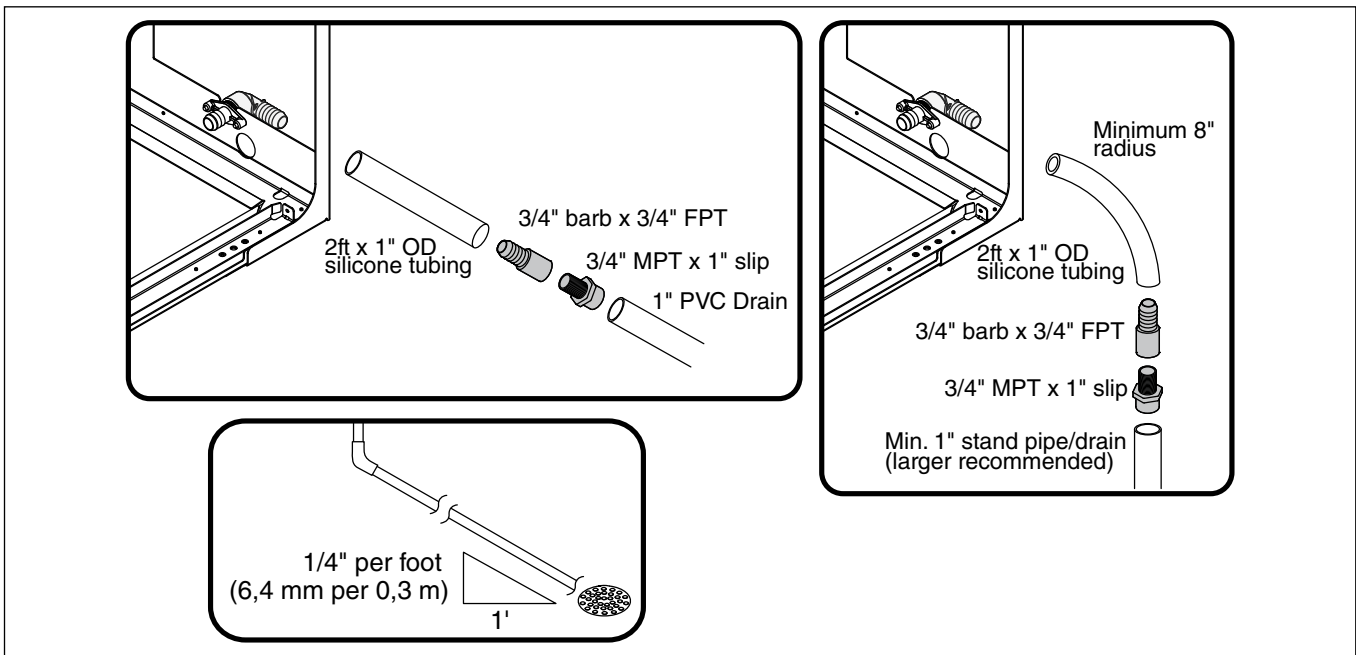

Chassis drain plumbing

- Route 3/8" drain tubing through knockout in back of docking station and insert fully into John Guest fitting connection at the rear of the machine chassis. Route other end of 3/8" drain tubing to drain.
- Drain must slope 1/4" inch per foot (6 mm per 30,4 cm).

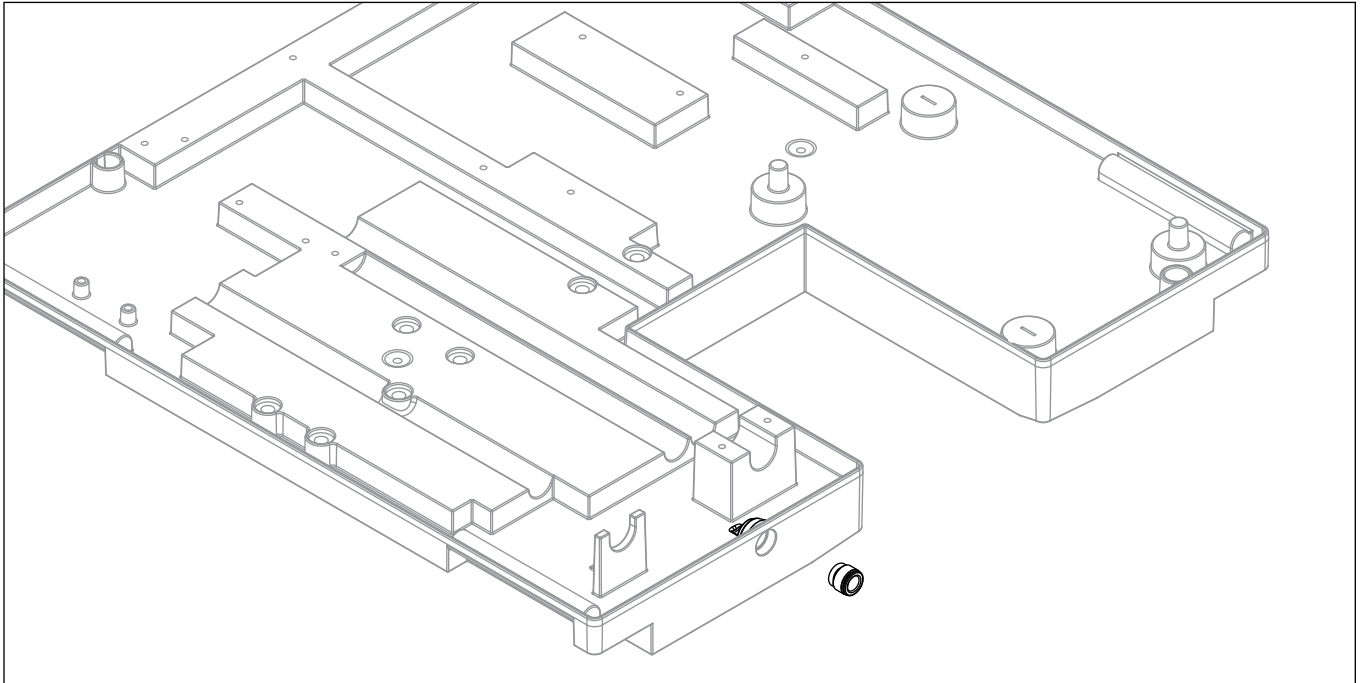

Ambient

Air temperature	100 F/38 C max.	50 F/10 C min.
Water temperature	90 F/32 C max.	45 F/7 C min.
Water pressure – potable	70 psi max. (483 kPa)	10 psi min. (89 kPa)

Heat rejection

	C1014	C1414
Air-cooled	12,000 BTU/hr	15,500 BTU/hr
Water-cooled	—	15,500 BTU/hr

Weight

	C1014A	C1414A/W
Approximate ship weight	205 lb (93 kg)	235 lb (107 kg)
Approximate net weight	195 lb (88 kg)	225 lb (102 kg)

Ice production

R290 Details

C1014 Air-cooled ice machine capacity/24 hrs.

Ambient Air Temperature F/C								
Evap Potable Water Temperature F/C	F	50	60	70	80	90	100	
	C	10	16	21	27	32	38	
50	1071	1023	975	929	882	843	801	lbs
10	486	464	443	422	400	383	364	kg
60	1011	969	926	879	833	801	759	lbs
16	459	440	421	399	378	364	344	kg
70	952	915	878	830	783	759	716	lbs
21	432	415	398	377	355	344	325	kg
80	892	860	829	784	740	716	674	lbs
27	405	391	376	356	336	325	306	kg
90	832	806	780	738	696	674	635	lbs
32	378	366	354	335	316	306	287	kg

C1414 Air-cooled ice machine capacity/24 hrs.

Ambient Air Temperature F/C								
Evap Potable Water Temperature F/C	F	50	60	70	80	90	100	
	C	10	16	21	27	32	38	
50	1472	1426	1379	1319	1258	1180	1122	lbs
10	668	647	626	599	571	536	510	kg
60	1394	1349	1303	1249	1195	1122	1065	lbs
16	633	612	592	567	543	510	483	kg
70	1316	1272	1228	1180	1132	1065	1007	lbs
21	597	577	557	536	514	483	457	kg
80	1237	1195	1152	1110	1069	1007	949	lbs
27	562	542	523	504	485	457	431	kg
90	1159	1118	1076	1041	1006	949	891	lbs
32	526	507	489	473	457	431	405	kg

C1414 Water-cooled ice machine capacity/24 hrs.

Condenser Water Temperature F/C								
Evap Potable Water Temperature F/C	F	50	60	70	80	90	100	
	C	10	16	21	27	32	38	
50	1253	1264	1274	1205	1136	1038	939	lbs
10	569	574	578	547	516	471	426	kg
60	1201	1205	1209	1142	1075	984	885	lbs
16	545	547	549	519	488	447	406	kg
70	1149	1146	1144	1079	1015	930	831	lbs
21	521	520	519	490	461	422	383	kg
80	1096	1088	1079	1016	954	876	777	lbs
27	498	494	490	461	433	398	363	kg
90	1044	1029	1014	954	893	822	744	lbs
32	474	467	460	433	405	373	338	kg

Dimensions and clearances

- Entire front of ice machine must be clear of obstructions/connections to allow removal.
- 1" (26 mm) clearance above ice machine for service.
- 1" (26 mm) minimum clearance on sides.
- 3" (78 mm) minimum clearance at rear.
- The intake and exhaust air grilles must provide at least 250 sq in (1615 sq cm) of open area.
- Air-cooled ice machines – 18" (458 mm) minimum clearance between discharge and air intake-grilles.

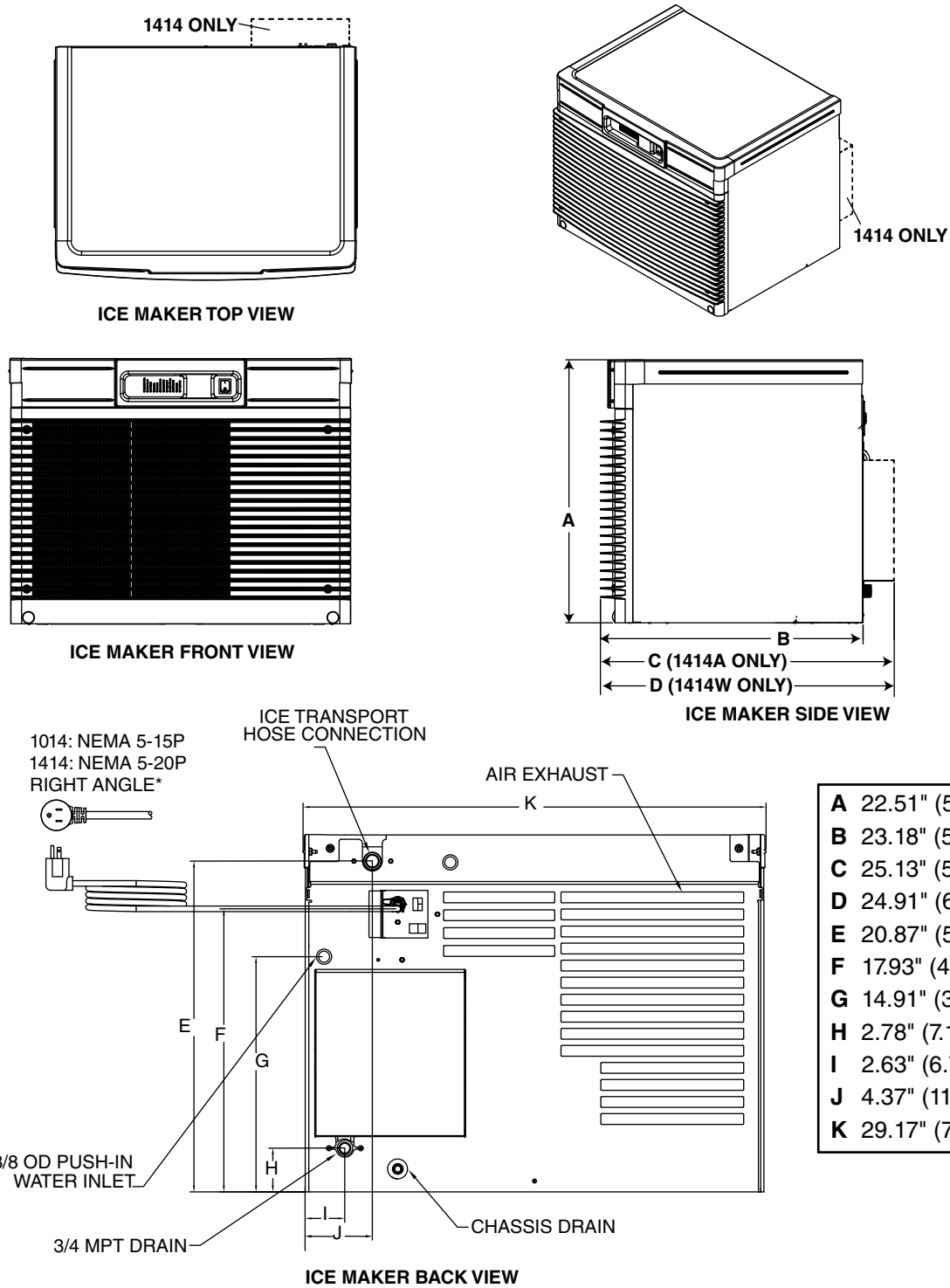

2. Follow the directions on the SafeCLEAN Plus packaging to mix 1 gal. (3.8 L) of Follett SafeCLEAN Plus solution. Use 120 F (49 C) water.
3. Using a 1 quart (1 L) container, slowly fill cleaning cup until CLEANER FULL light comes on and cleaner just begins to flow from the vent tube.
4. Place plastic plug and four SaniSponge™ cleaning sponges in remaining sanitizing and cleaning solution and retain for Step 8.

Note: Do not use bleach to sanitize or clean the icemaker.

Fig. 2

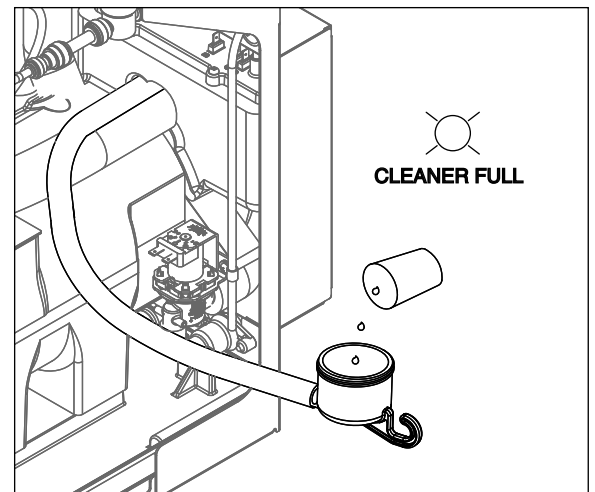

5. Replace cover on cleaner cup. Machine will clean, then flush 3 times in approximately 15 minutes. Wait until machine restarts.

Fig. 3

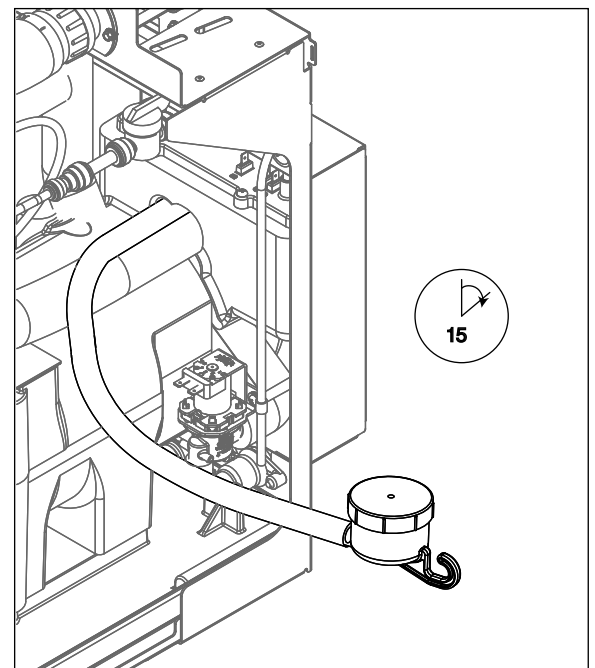

6. To clean/sanitize ice transport tube – Press power switch OFF

Fig. 4

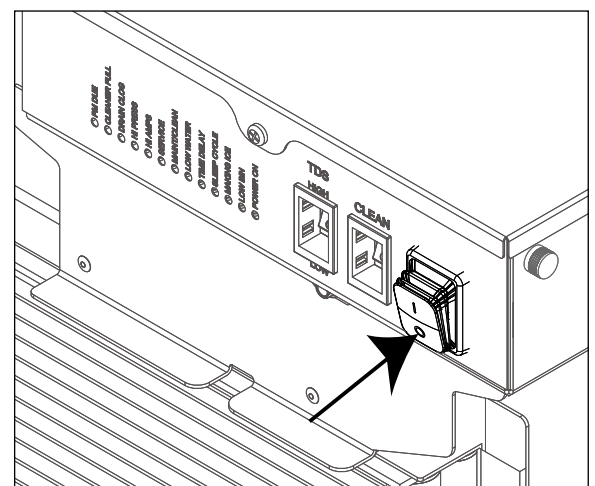

7. Disconnect coupling as shown.

Fig. 5

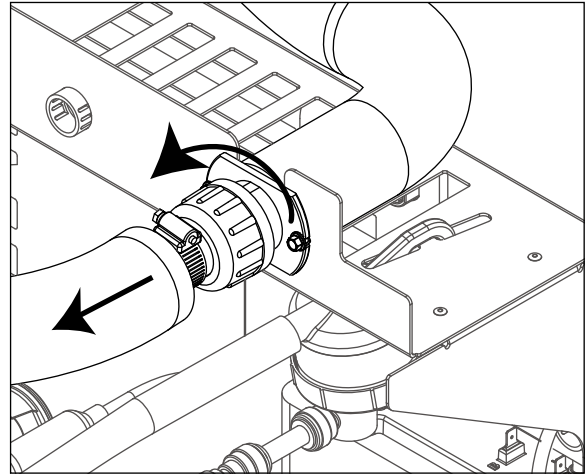

- 8. Using disposable foodservice grade gloves, insert red plastic plug (Fig. 6.1) followed by four SaniSponges (Fig. 6.2) saturated in cleaning solution (from Step 4).
- 9. Push plug and four SaniSponge cleaning sponges down ice transport tube with supplied pusher tube.

Fig. 6

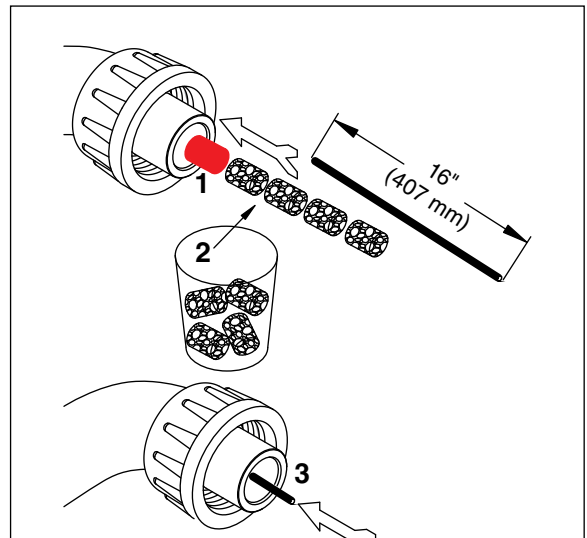

10. Remove and discard 16 inch (407 mm) pusher tube.

Fig. 7

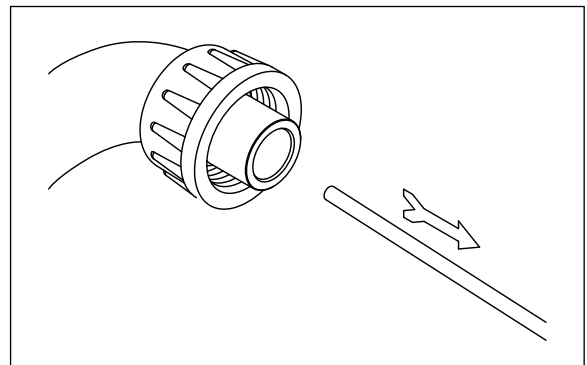

11. Fill internal ice transport tube with remaining cleaning solution.

Fig. 8

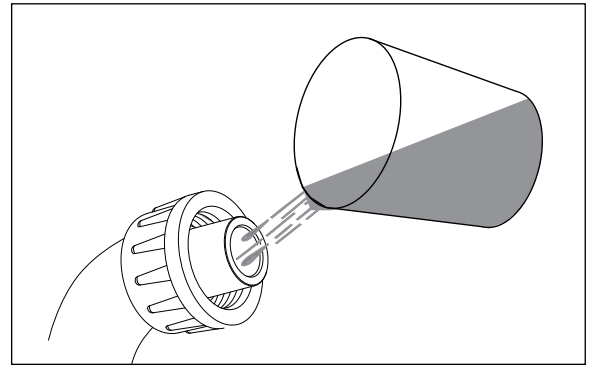

12. Reconnect coupling. Press power switch ON. Ice pushes plug and SaniSponge cleaning sponges through ice transport tube.

Fig. 9

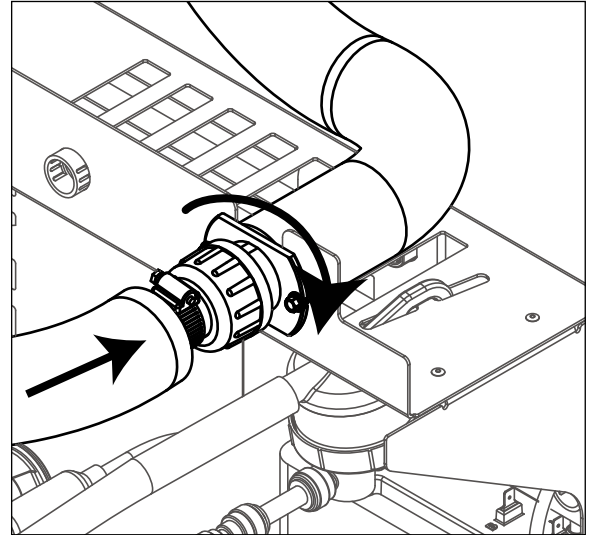

13. Place a sanitary (2 gal. or larger) container in bin or dispenser to collect the plug, SaniSponge cleaning sponges and ice for 15 minutes* *after the Sani-Sponges come out.*

* If cleaning a 700 series ice maker with an ice transport tube run that exceeds 20 feet, the ice must be collected for 30 minutes to ensure proper sanitization of the ice transport tube.

14. Discard ice, Sani-Sponges and plug. Return TDS switch to the original position.

Fig. 10

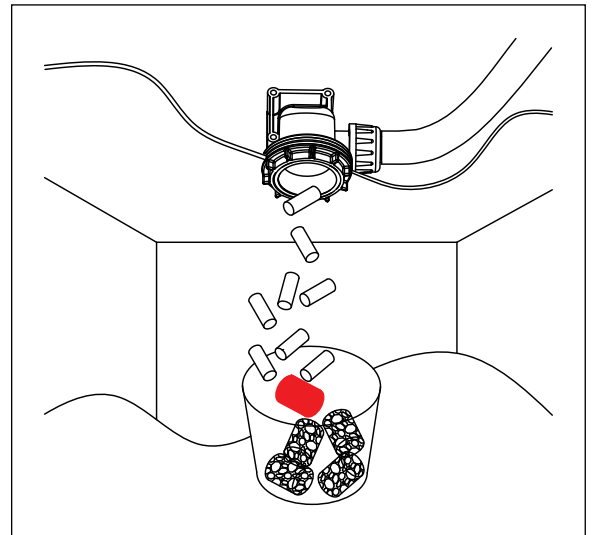

Refrigeration

Compressor data

	208-230 V 60 Hz	
	C1014	C1414
Compressor current draw at 208-230 VAC, 90 F/32.2 C	6.9A	12.1A
Locked rotor amps@ 208-230 V - Tecumseh	40.6A	90A
Locked rotor amps@ 208-230 V - Copeland	40.3A	56A
Compressor start winding (208-230 V)	2.74Ω	2.09Ω
Compressor run winding (208-230 V)	1.52Ω	0.73Ω

Gearmotor data

Gearmotor current 1.5A @ 208-230 V
 Gearmotor torque-out (high amp) trip point: 2.0A @ 208-230 V
 Locked rotor amps 8.2A @ 208-230 V

Resistance of windings

208-230 vac gearmotor (Brother):

Red to black: 11.8Ω
 Black to gray: 11.1Ω

Fan motor data

Fan motor current 1.1A @ 208-230 V

System Operating Pressures (Discharge/Suction) PSIG

Potable Water F/C							
Condenser Water F/C		50/10	60/16	70/21	80/27	90/32	
	50/10	290/32	290/32	290/32	290/33	290/33	psig
	60/16	290/33	290/33	290/33	290/33	290/33	psig
	70/21	290/33	290/33	290/33	290/33	290/33	psig
	80/27	293/33	293/33	293/33	293/33	293/33	psig
	90/32	295/34	295/34	295/34	295/34	295/34	psig

Note: The water control valve is factory set to maintain 190 ± 15 PSIG discharge pressure on R290 @ 70 F/21 C water.

Refrigeration system diagram (air-cooled units)

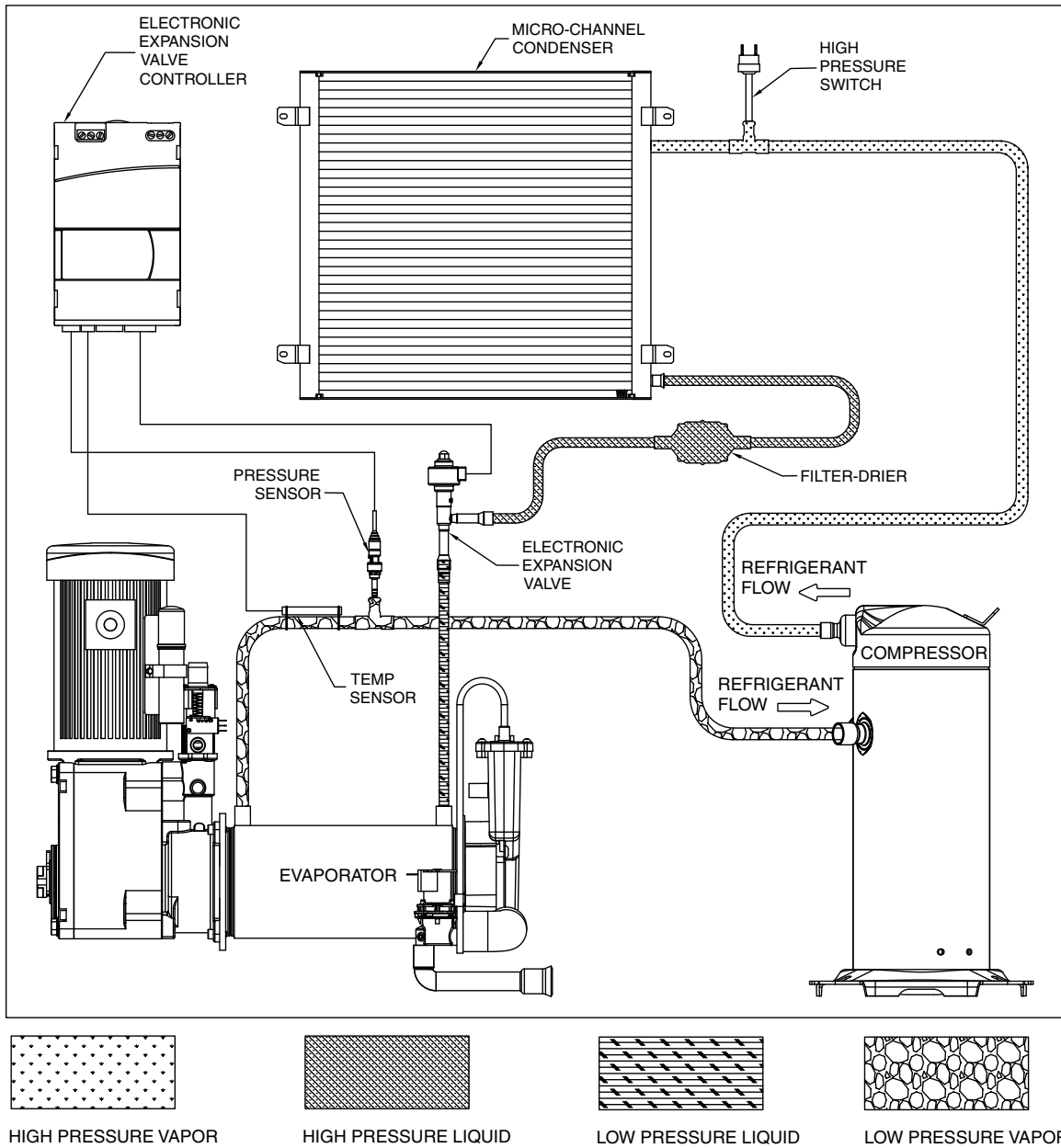

Refrigeration system diagram (water-cooled units)

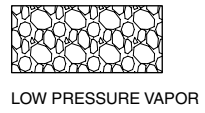
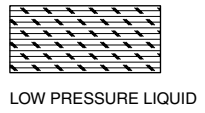
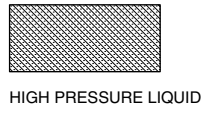
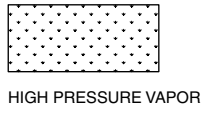
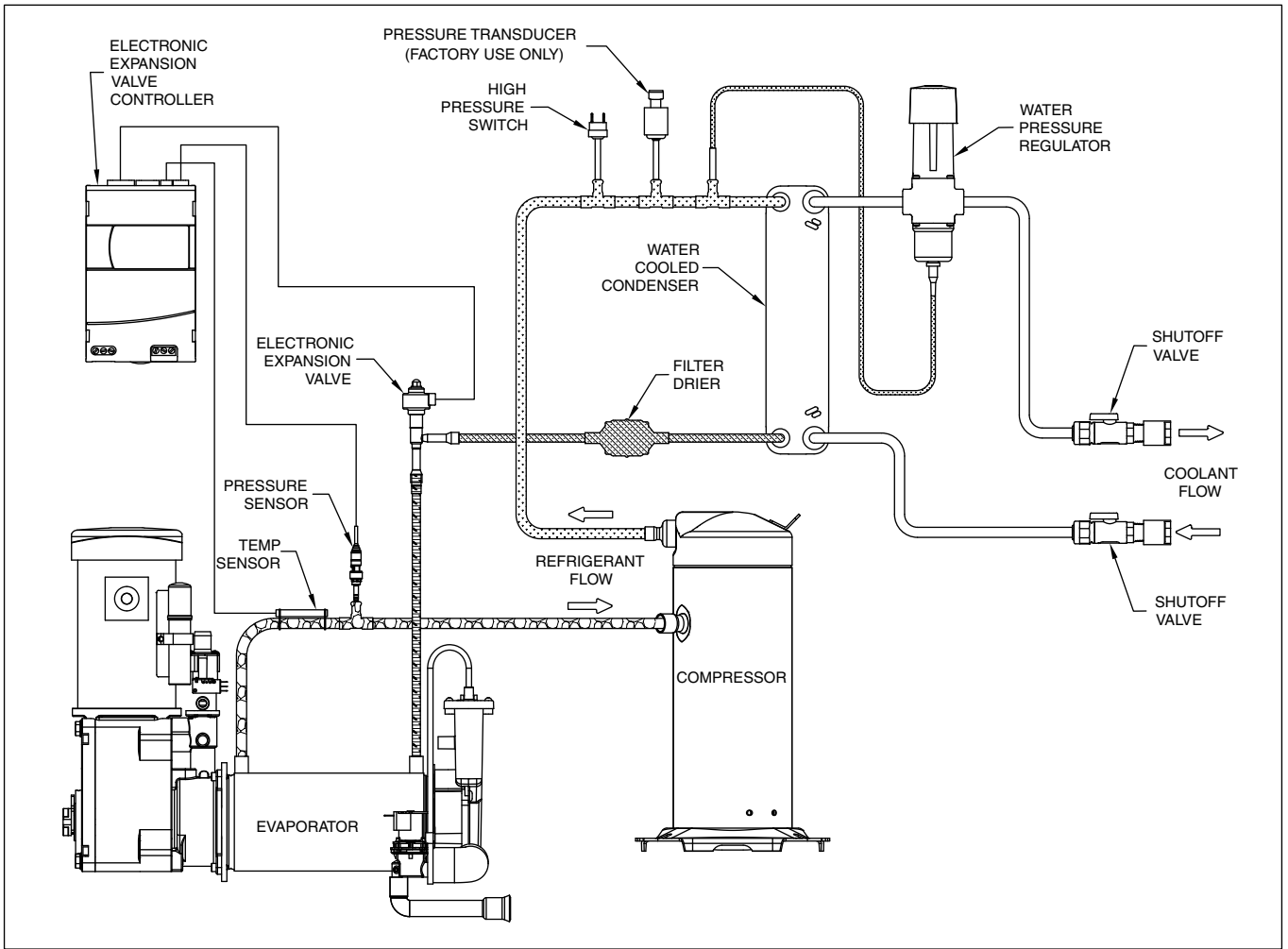

Refrigeration charge

All service on refrigeration systems must be performed in accordance with all federal, state and local laws. It is the responsibility of the technician to ensure that these requirements are met. Recharging ice machine to other than factory specifications will void the warranty.

Ice machine charge specifications

	Charge	Refrigerant type
C1014A	5.3 oz (150 g)	R290
C1414A	5.3 oz (150 g)	R290
C1414W	4.9 oz (140 g)	R290

Refrigerant replacement requirements

1. Non-contaminated refrigerant removed from any Follett refrigeration system can be recycled and returned to the same system after completing repairs. Recycled refrigerant must be stored in a clean, approved storage container. If additional refrigerant is required, virgin or reclaimed refrigerant that meets ARI standard 700-88 must be used.
2. In the event of system contamination (for example, a compressor burn out, refrigerant leak, presence of non-condensibles or moisture), the system must be repaired, evacuated and recharged using virgin or reclaimed refrigerant that meets ARI standard 700-88.
3. Follett Corporation does not approve of recovered refrigerants. Improper refrigeration servicing procedures will void the factory warranty.

Evacuation

Evacuate the system to a level of 500 microns. When the 500 micron level is reached, close all valves. Allow the system to sit for approximately 20 minutes. During this period the system pressure should not rise. If the system pressure rises and stabilizes there is moisture in the system and further evacuation is needed. If the pressure continues to rise check the system for leaks.

Ambients	Minimum	Maximum
Air temperature*	50 F/10 C	100 F/37.8 C
Water temperature†	45 F/7 C	90 F/32.2 C

* Ambient air temperature is measured at the air-cooled condenser coil inlet.

† Ambient water temperature is measured in the ice machine water reservoir.

Ice capacity test

Ice machine production capacity can only be determined by weighing ice produced in a specific time period.

1. Replace all panels on ice machine.
2. Run ice machine for at least 15 minutes.
3. Move TDS switch to LOW.
4. Weigh and record weight of container used to catch ice.
5. Catch ice for 15 minutes.
6. Weigh harvested ice and record total weight.
7. Subtract weight of container from total weight.
8. Convert fractions of pounds to decimal equivalents (ex. 6 lbs 8 oz = 6.5 lbs).
9. Calculate production using following formula:

$$\frac{1440 \text{ min.} \times \text{wt. of ice produced}}{\text{Total test time in minutes}} = \text{Production capacity/24 hr.}$$

10. Calculated amount per 24 hours should be checked against rated capacity for same ambient and water temperatures in Ice Production Tables.
11. **Move TDS switch to the HI TDS position.**

Troubleshooting

Ice machine disposition	Possible causes	Corrective action
Legend: ● ON ○ OFF ◐ ON or OFF ✖ FLASHING		
1. Ice machine is in running condition but not making ice. PM DUE CLEANER FULL ○ ○ DRAIN CLOG ○ ○ HI PRESS ○ ○ HI AMPS ○ ○ SERVICE ○ ○ MAINT/CLEAN ○ ○ LOW WATER ○ ○ TIME DELAY ○ ○ NOT USED ○ ○ MAKING ICE ○ ● LOW BIN ○ ● POWER ON ○ ✖	1. Defective compressor. 2. Defective start relay. 3. Defective start capacitor. 4. Defective run capacitor. 5. Defective main contactor. 6. No output from PC board.	1. Replace compressor. 2. Replace start relay. 3. Replace start capacitor. 4. Replace run capacitor. 5. Replace main contactor. 6. Replace PC board.
2. Machine in TIME DELAY without full bin. PM DUE CLEANER FULL ○ ○ DRAIN CLOG ○ ○ HI PRESS ○ ○ HI AMPS ○ ○ SERVICE ○ ○ MAINT/CLEAN ○ ○ LOW WATER ○ ○ TIME DELAY ○ ● NOT USED ○ ○ MAKING ICE ○ ○ LOW BIN ○ ● POWER ON ○ ✖	1. Ice jamming due to improperly installed transport tube causing a false shuttle. 2. Shuttle stuck in up position. 3. Damaged or improperly installed thermostat (open). 4. Transport tube backed-out of coupling.	1. Correct transport tube routing. 2. Repair or replace shuttle mechanism. 3. Replace or reposition thermostat. 4. Correct coupling installation.
3. Ice machine is not making ice. HI AMPS. PM DUE CLEANER FULL ○ ○ DRAIN CLOG ○ ○ HI PRESS ○ ○ HI AMPS ○ ● SERVICE ○ ○ MAINT/CLEAN ○ ○ LOW WATER ○ ○ TIME DELAY ○ ○ NOT USED ○ ○ MAKING ICE ○ ○ LOW BIN ○ ○ POWER ON ○ ✖	1. Poor water quality causing ice to jam auger. 2. Damaged shuttle mechanism. 3. Intermittent drive output from PC board. Evaporator will freeze causing a HI AMPS error. 4. Gearmotor is unplugged.	1. Clean ice machine. Increase flushing frequency. Position TDS switch to High TDS setting. 2. Replace or repair shuttle mechanism. 3. Replace PC board. 4. Plug in gearmotor.
4. Ice machine is not making ice. HI PRESSURE. PM DUE CLEANER FULL ○ ○ DRAIN CLOG ○ ○ HI PRESS ○ ● HI AMPS ○ ○ SERVICE ○ ○ MAINT/CLEAN ○ ○ LOW WATER ○ ○ TIME DELAY ○ ○ NOT USED ○ ○ MAKING ICE ○ ○ LOW BIN ○ ○ POWER ON ○ ✖	1. High ambient temperatures >100 F (38 C). 2. Poor ventilation or air recirculation. 3. Clogged condenser (air-cooled). 4. No water flow through condenser (water-cooled). 5. Fan not working properly. No air flow. <ul style="list-style-type: none"> • Blocked fan blades • No fan output from PC board • Faulty fan motor 	1. Air condition area to below 100 F (38 C). 2. Reposition ice machine or properly ventilate. Prevent ice machine exhaust from recirculating. 3. Clean condenser grille (air-cooled). 4. Restore water flow to condenser. 5. Correct air flow. <ul style="list-style-type: none"> • Remove any blockage from fan blades • Replace PC board • Replace fan motor
5. Ice machine is not making ice. SERVICE. PM DUE CLEANER FULL ○ ○ DRAIN CLOG ○ ○ HI PRESS ○ ○ HI AMPS ○ ○ SERVICE ○ ● MAINT/CLEAN ○ ○ LOW WATER ○ ○ TIME DELAY ○ ○ NOT USED ○ ○ MAKING ICE ○ ○ LOW BIN ○ ○ POWER ON ○ ✖	1. Internal water leak touching chassis sensor.	1. Identify and repair leak. Clean/dry chassis and sensors and restart machine. Ensure IM chassis condensate drain is plumbed and free flowing.
6. Drain clog. PM DUE CLEANER FULL ○ ○ DRAIN CLOG ○ ● HI PRESS ○ ○ HI AMPS ○ ○ SERVICE ○ ○ MAINT/CLEAN ○ ○ LOW WATER ○ ○ TIME DELAY ○ ○ NOT USED ○ ○ MAKING ICE ○ ○ LOW BIN ○ ○ POWER ON ○ ✖	1. Improper flow in drain system. 2. Failed purge solenoid.	1. Correct/clean drain system. 2. Replace purge solenoid

Ice machine disposition	Possible causes	Corrective action
Legend: <input checked="" type="radio"/> ON <input type="radio"/> OFF <input type="radio"/> ON or OFF <input checked="" type="radio"/> FLASHING		
<p>7. Ice machine is making ice. Excessive water in bin or coming into bin from transport tube.</p> <p> <input type="radio"/> PM DUE <input type="radio"/> CLEANER FULL <input type="radio"/> DRAIN CLOG <input type="radio"/> HI PRESS <input type="radio"/> HI AMPS <input type="radio"/> SERVICE <input type="radio"/> MAINT/CLEAN <input type="radio"/> LOW WATER <input type="radio"/> TIME DELAY <input type="radio"/> NOT USED <input type="radio"/> MAKING ICE <input checked="" type="radio"/> LOW BIN <input checked="" type="radio"/> POWER ON </p>	<ol style="list-style-type: none"> 1. Failed water sensors. Processor assumes there is no water when there is water. 2. Blocked reservoir vent. 3. Defective water feed solenoid valve. Stuck in open position. 4. Excessive water in bin. 	<ol style="list-style-type: none"> 1. Clean or replace water probe assembly. Check wiring connections. 2. Clean or replace vent tubes. 3. Replace water feed solenoid valve. 4. Water pressure too high/ out of spec.
<p>8. Ice machine is not making ice. Low Water.</p> <p> <input type="radio"/> PM DUE <input type="radio"/> CLEANER FULL <input type="radio"/> DRAIN CLOG <input type="radio"/> HI PRESS <input type="radio"/> HI AMPS <input type="radio"/> SERVICE <input type="radio"/> MAINT/CLEAN <input type="radio"/> LOW WATER <input checked="" type="radio"/> TIME DELAY <input type="radio"/> NOT USED <input type="radio"/> MAKING ICE <input type="radio"/> LOW BIN <input checked="" type="radio"/> POWER ON </p>	<ol style="list-style-type: none"> 1. Water supply is insufficient. 2. Low water pressure. 3. Defective water feed solenoid valve. Stuck in closed position. 4. No water feed output from PC board. 5. Plugged screen on inlet side of fill solenoid. 6. Plugged check valve. 	<ol style="list-style-type: none"> 1. Restore water supply and check water filters. If evaporator was completely empty the reset button may have to be pressed to restart the ice machine. 2. Ice machine will eventually start when water reaches normal lo level. 3. Replace water feed solenoid valve. 4. Replace PC board. 5. Remove and clean screen. 6. Remove and clean.
<p>9. Blinking Low Water, power, time delay.</p> <p> <input type="radio"/> PM DUE <input type="radio"/> CLEANER FULL <input type="radio"/> DRAIN CLOG <input type="radio"/> HI PRESS <input type="radio"/> HI AMPS <input type="radio"/> SERVICE <input type="radio"/> MAINT/CLEAN <input checked="" type="radio"/> LOW WATER <input type="radio"/> TIME DELAY <input type="radio"/> NOT USED <input type="radio"/> MAKING ICE <input type="radio"/> LOW BIN <input checked="" type="radio"/> POWER ON </p>	<p>Machine did not see water consumption while trying to make ice.</p> <ol style="list-style-type: none"> 1. Lack of refrigeration/low refrigerant charge/leak. 2. Debris shorting reservoir probes. 3. VFD error. 	<ol style="list-style-type: none"> 1. Verify refrigerant pressures, compressor running, sight glass clear. 2. Clean probes and reservoir of debris. 3. Call Follett Technical Support.
<p>10. Solid PM Due.</p> <p> <input checked="" type="radio"/> PM DUE <input type="radio"/> CLEANER FULL <input type="radio"/> DRAIN CLOG <input type="radio"/> HI PRESS <input type="radio"/> HI AMPS <input type="radio"/> SERVICE <input type="radio"/> MAINT/CLEAN <input type="radio"/> LOW WATER <input type="radio"/> TIME DELAY <input type="radio"/> NOT USED <input type="radio"/> MAKING ICE <input type="radio"/> LOW BIN <input checked="" type="radio"/> POWER ON </p>	<ol style="list-style-type: none"> 1. Ice machine has been in service for 6 month interval without being cleaned. 	<ol style="list-style-type: none"> 1. Clean Ice machine.



ATTENTION!

To prevent circuit breaker overload, wait 5 minutes before restarting this unit. This allows the compressor to equalize and the evaporator to thaw.

Warranty Registration and Equipment Evaluation

Thank you for purchasing Follett equipment. Our goal is to earn your complete satisfaction by delivering high-value products and services backed by outstanding customer and technical support.

Please review the installation instructions thoroughly. It is important that the installation be performed to factory specifications so your equipment operates at its maximum efficiency.

Follett Products LLC will not be liable for any consequential damages, expenses, connecting or disconnecting charges, or any losses resulting from a defect of the machine. For full warranty details, visit our website www.follettice.com/productwarranties.

Registering your equipment helps Follett track your equipment's service history should you need to contact us for technical support, and your feedback helps us improve our products and services. Please visit www.follettice.com/support to complete the Warranty Registration form.

Should you have any questions, please contact Follett's technical support group at (877) 612-5086 or (610) 252-7301 and we will be happy to assist you.

Horizon Elite, SafeCLEAN Plus and SaniSponge are trademarks of Follett Products, LLC
Follett is a registered trademark of Follett Products, LLC, registered in the US.



801 Church Lane • Easton, PA 18040, USA
Toll free (877) 612-5086 • +1 (610) 252-7301
www.follettice.com

01582576R00
© Follett Products, LLC 3/26