

Infinity Series™

medical-grade countertop refrigerators



LED controls with optional keypad

Model configurations				
Controls	Hinging ¹	Keypad	Door style	Item number
LED	right	no	stainless	REF1i
	right	yes	stainless	REF1i-KP

¹ As facing the unit.



LED controls with optional keypad

Model configurations				
Controls	Hinging ¹	Keypad	Door style	Item number
LED	right	no	stainless	REF2i
	right	yes	stainless	REF2i-KP

¹ As facing the unit.

Features

Patented “infinite speed” control technology delivers superior temperature, noise and energy management

- variable capacity compressor and microprocessor controller provide a ± 1 C (1.8 F) temperature performance throughout the cabinet
- low GWP natural refrigerant R600a
- extremely quiet
- ENERGY STAR® certified

Protection, convenience and security for your valuable products

- UL certified to meet NSF/ANSI 456 standard for vaccine storage
- exterior LED displays product temperature in user-selectable F or C
- “sleep mode” turns off display
- user-programmable, audible and visual high/low alarms
- rechargeable battery (-KP models only)
- adjustable refrigeration set points are accessed through front controls
- quick-connect product temperature probe with 1 year certificate of NIST-traceable calibration
- cylinder door lock (non -KP models only)
- back wall port provides entry for third-party probes
- flush door design is compatible with standard automated dispensing system brackets

Durability and serviceability

- stainless steel construction on exterior and interior
- rubberized feet
- epoxy-coated wire shelf – (1) REF1i and (2) REF2i
- heavy-duty edge-mount self-closing hinges
- field-reversible door
- removable back panel for easy service access to compressor, condenser and fans
- dart-type magnetic gasket
- dished floor for easy cleanup

Warranty

- 2 year parts and labor
- 5 year compressor parts only
- see page 2 for optional extended warranties

Certifications (applied to all products unless otherwise noted)



Vaccine Refrigerator
NSF 456 – E524732
Laboratory Equipment
SAFETY US/CA – E520098



Options and accessories¹

Additional shelf (1) (item# 00969956)

Organizing bins, 6 (item# 00969931)

Casters (set of 4) (item# 01111947)

Pedestal, 12.00" (30.5 cm) (item# 01025881)

Stacking kit (countertop on countertop) (item# 01100742)

Stacking kit (countertop on undercounter) (item# 01100759)

Glycerine, 16 oz (item# 00959296)

Replacement overmolded NTC probe with NIST-traceable certificate of calibration (item# 01588961)

Temperature surveillance module (includes alarm, 8.00" (20.32 cm) chart recorder, remote contacts) (item# 01570860)

Dry contact kit for refrigerators and freezers for connection to remote alarm systems (item# 01590579)

DicksonOne VFC-compliant freestanding display data logger with Wi-Fi and Ethernet capability for use with any refrigerator or freezer (item# 01528512). NOTE: Subscription from Dickson required to access data on the cloud.

DicksonOne VFC-compliant freestanding touchscreen data logger with Power Over Ethernet and Wi-Fi capability for use with any refrigerator or freezer (item# 01528538). NOTE: Subscription from Dickson required to access data on the cloud.

Ambient temperature and humidity sensor, right angle, for use with DicksonOne freestanding display and touchscreen data loggers (item# 01539691)

Optional extended one year warranty (item# EW12)

- 3 year parts and labor

- 5 year compressor parts only

Optional extended three year warranty (item# EW36)

- 5 year parts and labor

For additional accessories, refer to the form# 8550.

NOTE: Accessories ship separately.

¹ Certifications do not apply to options and accessories.

Dimensional drawing

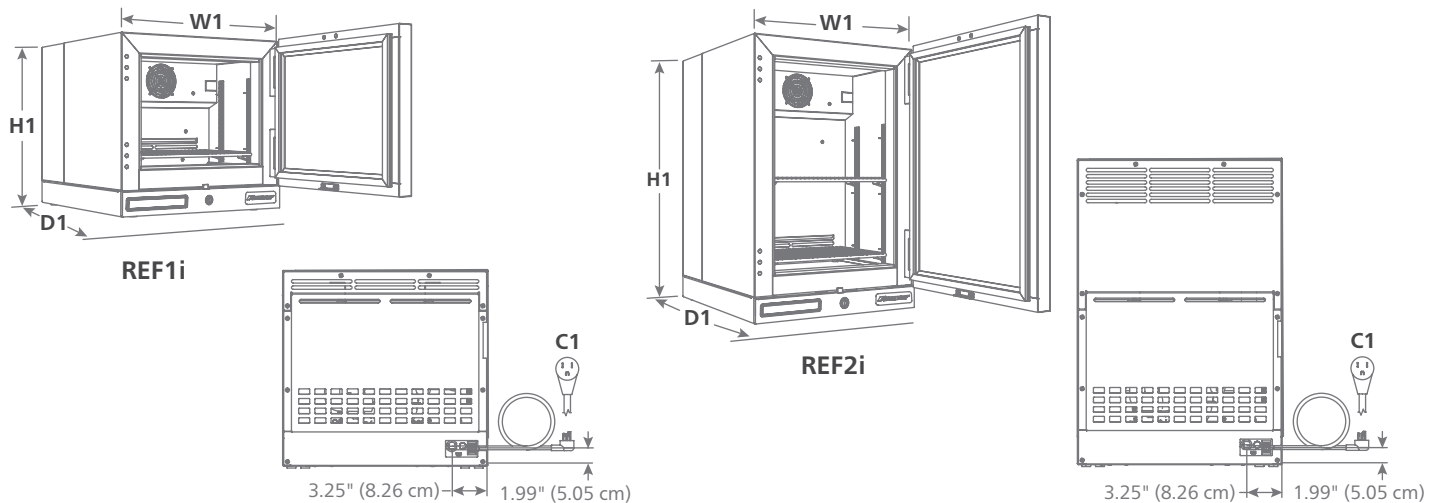

Specification

Nominal capacity	REF1i – 1 cu ft (28 L) REF2i – 1.8 cu ft (51 L)
Ventilation clearance with more than 8.00" (20.32 cm) top clearance	2.00" (5.08 cm) for both sides
Ventilation clearance with less than 8.00" (20.32 cm) top clearance	6.00" (15.24 cm) for one side

Exterior

W1 Width	18.60" (47.2 cm)
Depth at top	24.00" (61.0 cm)
D1 Depth at bottom	20.00" (50.8 cm)
H1 Height	REF1i – 17.93" (45.5 cm) REF2i – 27.93" (70.9 cm)
Door swing	standard with self-closing right hinge, field reversible

Interior

Width	14.50" (36.8 cm)
Depth	10.00" (25.4 cm)
Height	REF1i – 11.25" (28.6 cm) REF2i – 21.25" (54.0 cm)
Storage system	REF1i – (1) 13.81" x 9.06", (35.08 cm x 23.01 cm) epoxy-coated wire shelf REF2i – (2) 13.81" x 9.06", (35.08 cm x 23.01 cm) epoxy-coated wire shelves

Door configurations

Door	stainless steel
Door lock	cylinder door lock with 2 keys or electronic lock (-KP models only)
Door hinges	edge-mount, self-closing
Gasket	magnetic, dart-style

Electrical

C1 115 V/60/1 electrical	1.5 full load amps, NEMA 5-15P 90° hospital-grade plug, low profile, SJT, 16 AWG, 8' (2.4 m) cord
---------------------------------	---

Controls

Temperature display	standard 7 segment LED, default set in C, user-selectable F or C
Display sleep function	button turns off display, press again to turn back on
Factory preset	4.4 C
Probes	3 probes: P1 controls refrigeration system; P2 controls defrost; P3 provides product temperature
Product simulation bottle	(1) 60 ml
Programmable operating range	2.2 to 10 C (36 to 50 F)

Alarming

High and low product temperature alarm	audible and visual, user programmable set points in F or C
Alarm	user-programmable high/low; audible and visual alert; audible alarm mute
Alarm delay	user-programmable 0 to 255 min

System performance

Refrigerant and charge	R600a refrigerant, 1.4 oz charge
Automatic defrost	off-cycle defrost
Energy consumption	REF1i – 0.39 kWh/day REF2i – 0.48 kWh/day
Max heat rejection	788 BTU/hr (231 W)

Shipping

Shipping size	REF1i – 30.00" x 33.00" x 35.00" (76.2 x 83.8 x 88.9 cm)
W x D x H	REF2i – 30.00" x 33.00" x 35.00" (76.2 x 83.8 x 88.9 cm)
Approximate net weight	REF1i – 62 lb (28.1 kg) REF2i – 76 lb (34.5 kg)
Approximate ship weight	REF1i – 111 lb (50.4 kg) REF2i – 135 lb (61.3 kg)

NOTE: For indoor use only

SHORT FORM SPECS:

Infinity Series countertop refrigerator with variable capacity compressor (choose one) with ____ 1.0 cu ft (28 L) or ____ 1.8 cu ft (51 L) of nominal capacity and solid stainless steel door. Fits on standard 24.00" (61.0 cm) deep countertop and under standard 18.00" (45.7 cm) wall-hung cabinets (REF1i models only). Includes (1) epoxy-coated wire shelf on REF1i models and (2) epoxy-coated wire shelves on REF2i models, adjustable in 1/2" increments. Each unit comes standard with a quick-connect NTC probe with one-year certificate of NIST-traceable calibration. Environmentally responsible R600a forced-air cooled refrigeration system. Bottom-mounted controls display product temperature in user-selectable C or F. Integral high and low temperature alarming. Storage area insulated with CARB compliant non-HFC foam. 8' (2.4 m) power cord with NEMA 5-15 90° hospital-grade plug. UL certified to meet NSF/ANSI 456 standard for vaccine storage. ENERGY STAR certified.

ENERGY STAR and the ENERGY STAR mark are registered trademarks owned by the U.S. Environmental Protection Agency.
INFINITY SERIES is a trademark of Follett Products, LLC.
FOLLETT and FOLLETT HEALTHCARE are registered trademarks of Follett Products, LLC, registered in the US.
Follett reserves the right to change specifications at any time without obligation.

Infinity Series countertop refrigerators

1119-20260513 | © Follett Products, LLC

801 Church Lane | Easton, PA 18040, USA
1.800.523.9361 | 1.610.252.7301 | folletthealthcare.com

