

FBC-5T-RH/FBC-10T-RH/FBC-15T-RH

blast chillers/shock freezers, reach-in



FBC-5T-RH



FBC-10T-RH



FBC-15T-RH

Features

Commercial blast chillers and blast freezers are designed to rapidly chill and shock freeze ingredients and prepared food down to safe temperatures, quickly.

Preserve nutrients, aid in reducing food waste and minimize preparation times

Exceed food safety standards¹

- chill from 194 F to 37 F (90 C to 3 C) in 90 minutes
- freeze from 194 F to 0 F (90 C to -18 C) in 270 minutes

7" digital touchscreen control allows for preset chill, freeze, and thaw cycles with custom recipe creation

Advanced control system includes cycles such as soft chill, hard chill, soft freeze, hard freeze, thawing, holding, and end of cycle mode

Multi-core probe with 4 reading points

Powerful refrigeration system

- high efficiency compressor, bottom mount
- non-ozone depleting, low GWP R449a refrigerant
- self-lubricating, sealed cast iron evaporator fan motor with high volume air flow design
- automatic defrost
- operating temperature range: -40°F to 50°F

Cabinet construction

- full stainless steel AISI 304 construction provides resistance to rust and corrosion
- CFC-free high-density polyurethane insulated cabinet
- interior rounded corners, removable door gasket, and evaporator compartment for easy cleaning
- self-closing door with 105° stop
- 4 casters, two locking

Warranty

- 3 years parts and labor, 5 years compressor parts only

Certifications (applied to all products unless otherwise noted)



Model configurations			
Description	Hinging	V/Hz/Ph/A	Item number
5 tray	right	115/60/1/20	FBC-5T-RH
10 tray	right	230/60/3/10	FBC-10T-RH
15 tray	right	230/60/3/16	FBC-15T-RH

¹ All tests completed using 2.00" (5.08 cm) thick food product.

Specification

Capacity	FBC-5T-RH: (5) 18" x 26" sheet pans or (2) 12" x 20" x 2.50" H steam table pans (pans not included) FBC-10T-RH: (10) 18" x 26" sheet pans or (5) 12" x 20" x 2.50" H steam table pans (pans not included) FBC-15T-RH: (15) 18" x 26" sheet pans or (7) 12" x 20" x 2.50" H steam table pans (pans not included)
Ventilation clearance	12.00" (30.5 cm) from back wall, 20.00" (50.8 cm) from side walls and top

Exterior

Width	FBC-5T-RH: 31.50" (80.0 cm) FBC-10T-RH: 31.50" (80.0 cm) FBC-15T-RH: 31.50" (80.0 cm)
Depth	FBC-5T-RH: 31.69" (80.5 cm) FBC-10T-RH: 32.88" (83.5 cm) FBC-15T-RH: 32.88" (83.5 cm)
Height with casters	FBC-5T-RH: 33.47" (85.0 cm) FBC-10T-RH: 64.34" (163.4 cm) FBC-15T-RH: 77.31" (196.4 cm)
Casters	set of 4, 2 locking

Door configurations

Door	self closing with 105° stop
------	-----------------------------

Electrical

factory pre-wired dedicated outlet with cord	FBC-5T-RH: 115V/60Hz/1, 20 Amps, NEMA 5-20P plug FBC-10T-RH: 230V/60Hz/3, 10 Amps, NEMA L15-30P plug FBC-15T-RH: 230V/60Hz/3, 16 Amps, NEMA L15-30P plug
--	--

Controls

Temperature display	7" digital touchscreen control with HACCP data tracker and alarms
Probe	multi-core, 4 reading points
Programmable operating range	-40 F to 50 F (-40 C to 10 C)

System performance

Blast chilling yield	FBC-5T-RH: 194 F to 37 F (90 C to 3 C) in 90 minutes – 44.09 lb (20 kg) FBC-10T-RH: 194 F to 37 F (90 C to 3 C) in 90 minutes – 77.16 lb (35 kg) FBC-15T-RH: 194 F to 37 F (90 C to 3 C) in 90 minutes – 143.3 lb (65 kg)
Shock freezing yield	FBC-5T-RH: 194 F to 0 F (90 C to -18 C) in 270 minutes – 26.46 lb (12 kg) FBC-10T-RH: 194 F to 0 F (90 C to -18 C) in 270 minutes – 55.11 lb (25 kg) FBC-15T-RH: 194 F to 0 F (90 C to -18 C) in 270 minutes – 110.23 lb (50 kg)
Refrigerant	R449a
Refrigerant charge	FBC-5T-RH: 35.3 oz (1 kg) FBC-10T-RH: 70.5 oz (2 kg) FBC-15T-RH: 88.2 oz (2.5 kg)
Energy consumption and horsepower	FBC-5T-RH: 6400 BTU/hr (1876 Watts), 1.6 HP FBC-10T-RH: 3826 BTU/hr (1121 Watts), 1.8 HP FBC-15T-RH: 6081 BTU/hr (1782 Watts), 3 HP

Shipping

Shipping dimensions (W x D x H)	FBC-5T-RH: 36.61" x 35.43" x 43.31" (93.0 x 90.0 x 110.0 cm) FBC-10T-RH: 34.65" x 33.46" x 83.86" (88.0 x 85.0 x 213.0 cm) FBC-15T-RH: 37.80" x 34.65" x 84.65" (96.0 x 88.0 x 215.0 cm)
Approximate ship weight	FBC-5T-RH: 287 lb (130 kg) FBC-10T-RH: 463 lb (210 kg) FBC-15T-RH: 541 lb (245 kg)

NOTE: For indoor use only

Dimensional drawing

FBC-5T-RH

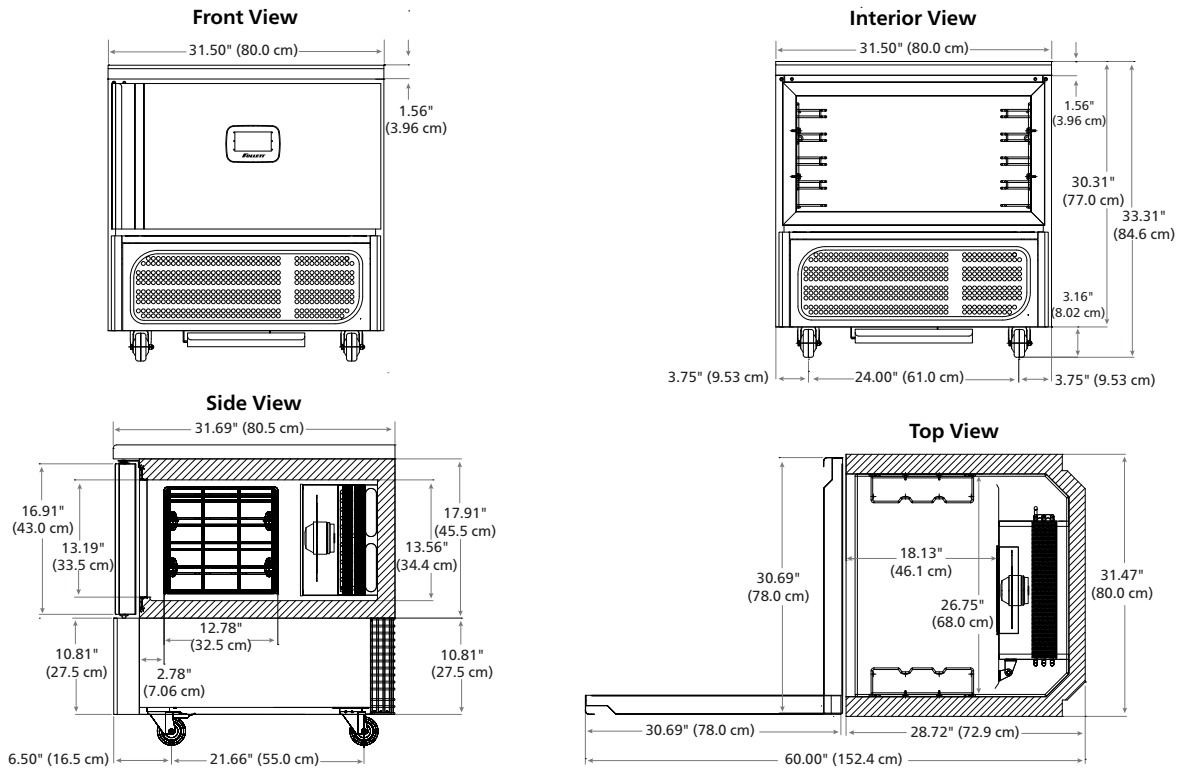

FBC-10T-RH

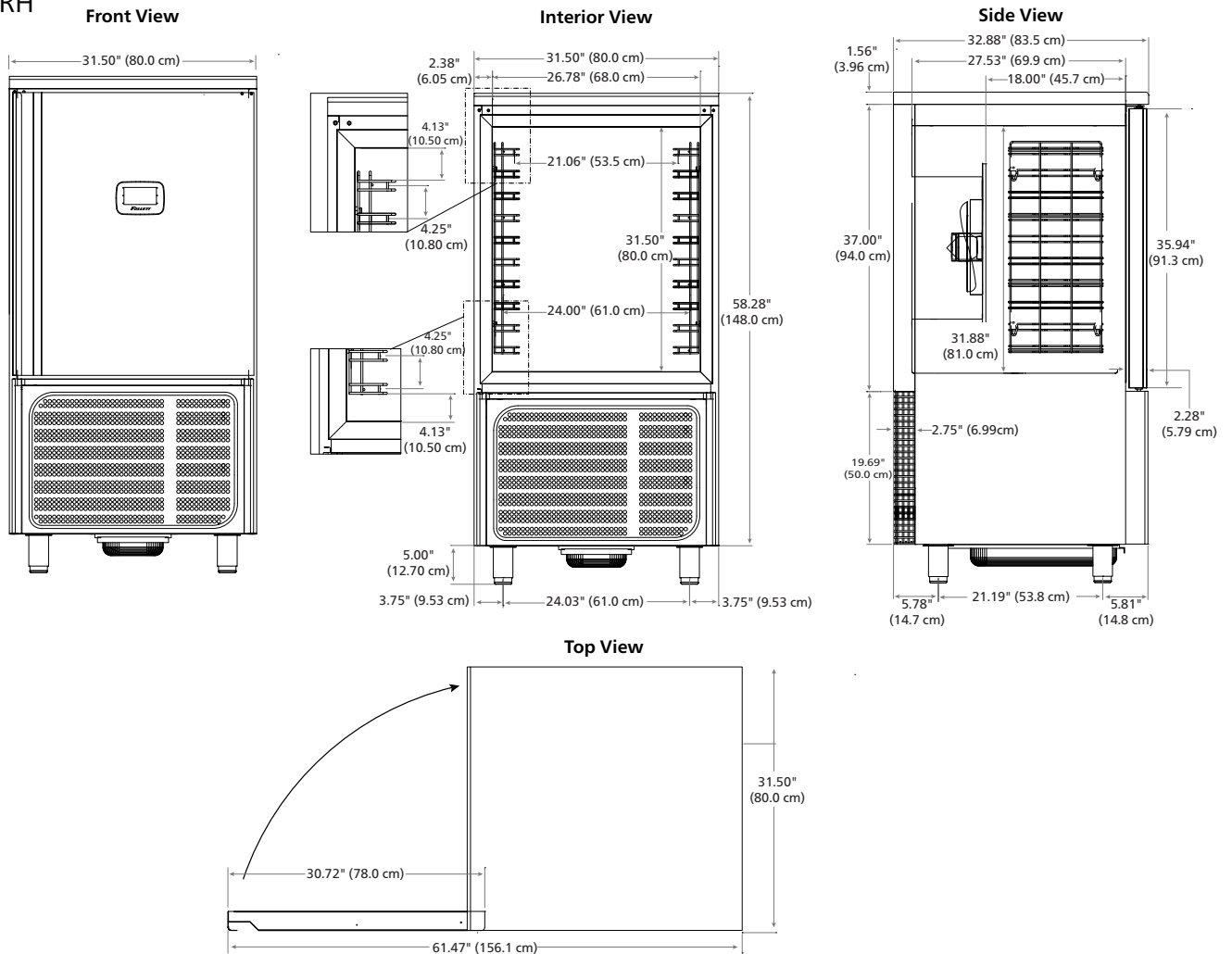

FBC-15T-RH

Front View

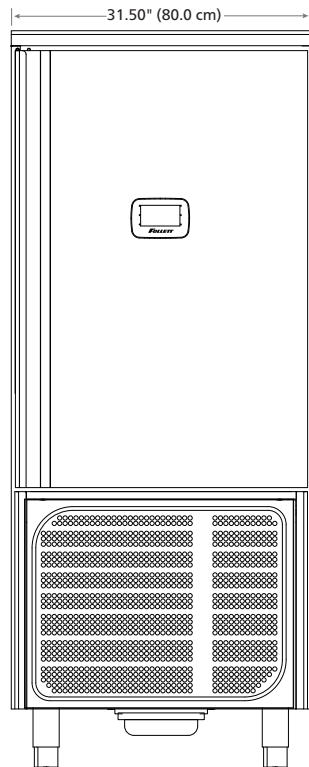

Interior View

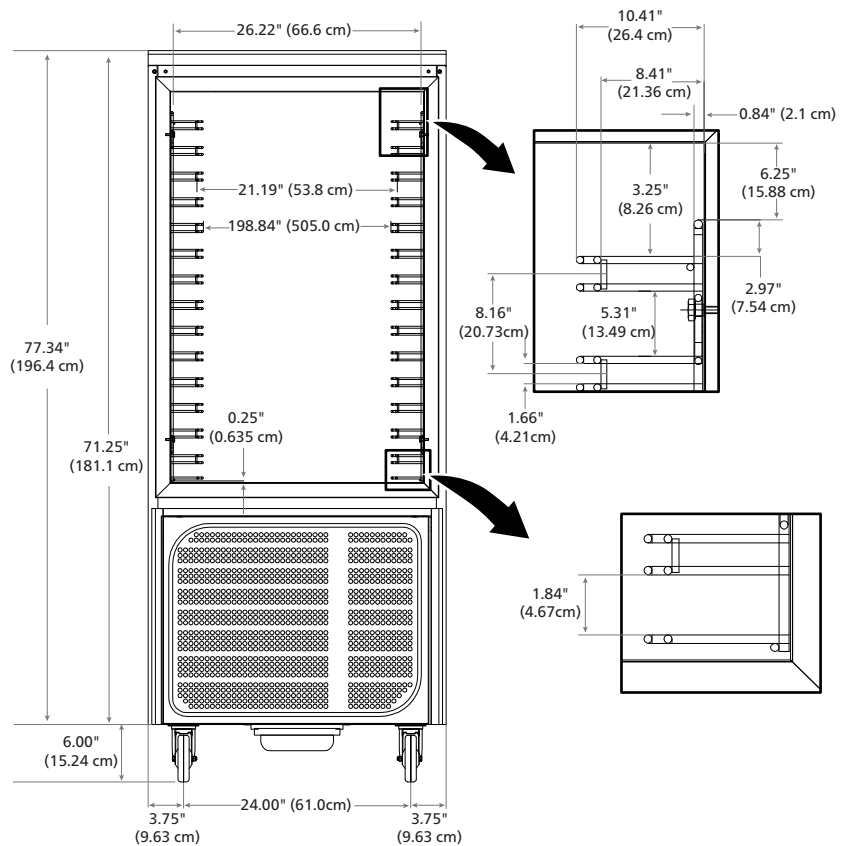

Side View

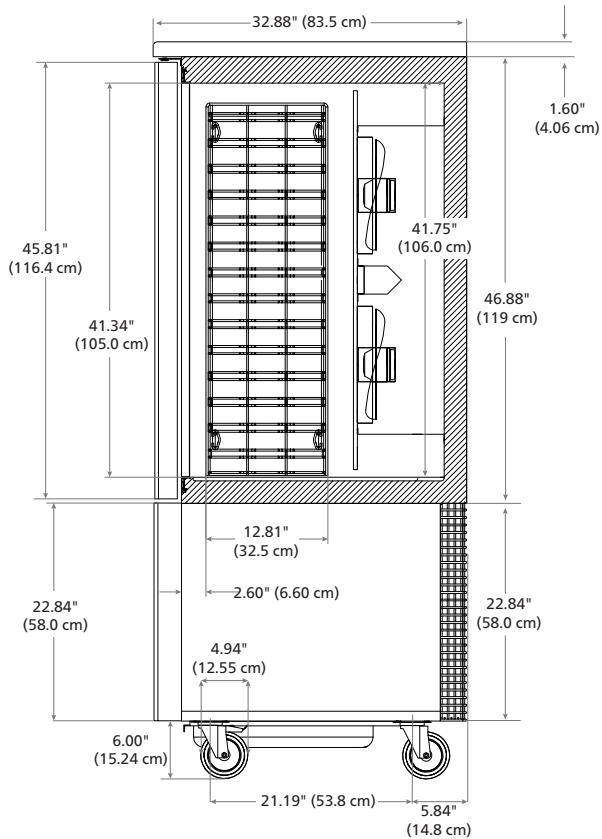

Top View

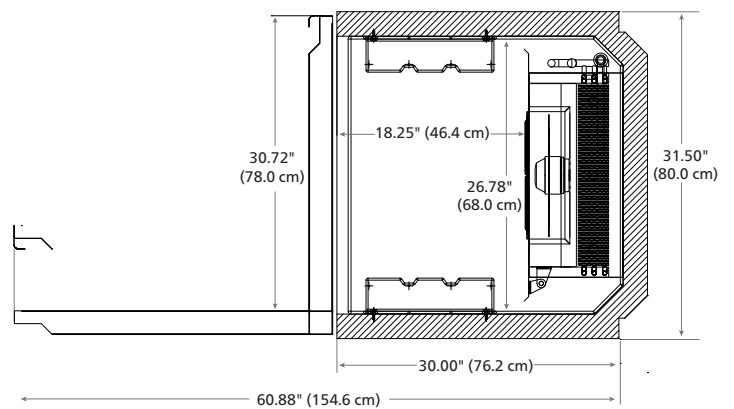

FOLLETT is a registered trademarks of Follett Products, LLC, registered in the US. Follett reserves the right to change specifications at any time without obligation.

Blast chillers/shock freezers, reach-in

1152-20260501 | © Follett Products, LLC

801 Church Lane | Easton, PA 18040, USA
1.800.523.9361 | 1.610.252.7301 | follettice.com

