

FBC-20T-RH

1 Trolley roll-in blast chillers/shock freezers,
with remote compressor



FBC-20T-RH (cabinet)



**Remote condenser unit
(included, assembly required)**



Quick disconnects (included)

Features

Commercial blast chillers and blast freezers are designed to rapidly chill and shock freeze ingredients and prepared food down to safe temperatures, quickly.

Preserve nutrients, aid in reducing food waste and minimize preparation times

Roll-in unit fits 1 full-sized speed rack or combi cart (not included)

Exceed food safety standards¹

- chill from 194 F to 37 F (90 C to 3 C) in 90 minutes
- freeze from 194 F to 0 F (90 C to -18 C) in 270 minutes

7" digital touchscreen control allows for preset chill and freeze cycles and custom recipe creation

Advanced control system includes cycles such as soft chill, hard chill, soft freeze, hard freeze, holding, and end of cycle mode

Multi-core probe with 4 reading points

Powerful refrigeration system

- pre-charged compressor
- 33.00' (1005.84 cm) of pre-charged line with quick disconnects
- non-ozone depleting, low GWP R449a refrigerant
- self-lubricating, sealed cast iron evaporator fan motor with high volume air flow design
- automatic defrost
- operating temperature range: -40°F to 50°F

Cabinet construction

- full stainless steel AISI 304 construction provides resistance to rust and corrosion
- interior rounded corners, removable door gasket, and evaporator compartment for easy cleaning
- self-closing door with 105° stop, lock included
- 5.50" (13.97 cm) ramp

Warranty

- 3 years parts and labor, 5 years compressor parts only

Certifications (applied to all products unless otherwise noted)



Model configurations			
Description	Hinging	V/Hz/Ph/A	Item number
1 trolley (cabinet)	right	208-220/60/1/4	FBC-20T-RH
Remote condenser	N/A	208-220/60/3/15	

¹ All tests completed using 2.00" (5.08 cm) thick food product.

Specification

Capacity 1 full-sized speed rack (18" x 26" sheet pans) or 1 combi cart (70.055" H x 30.35" W x 35.15" D) (not included)

Ventilation clearance Condenser: 40.00" (101.6 cm) on all sides

Exterior

Width Cabinet: 59.00" (149.9 cm)
Remote condenser: 56.13" (142.6 cm)

Depth Cabinet: 50.75" (129.0 cm)
Remote condenser: 40.50" (102.9 cm)

Height Cabinet: 88.88" (225.8 cm)
Remote condenser: 28.00" (71.1 cm)

Door configurations

Door self closing with 105° stop and lock

Electrical

Cabinet: 208-220V/60Hz/1, 4 Amps, dedicated 50 amp circuit required
Remote Condenser: 208-220V/60Hz/1, 15 Amps, dedicated 50 amp circuit required
Compressor: No plug, installer to add a plug or hardwire

Controls

Temperature display 7" digital touchscreen control with HACCP data tracker and alarms

Probe multi-core, 4 reading points

Programmable operating range -40 F to 50 F (-40 C to 10 C)

System performance

Blast chilling yield 194 F to 37 F (90 C to 3 C) in 90 minutes – 440.93 lb (200 kg)

Shock freezing yield 194 F to 0 F (90 C to -18 C) in 270 minutes – 385.81 lb (175 kg)

Refrigerant R449a

Refrigerant charge 212 oz (6.0 kg)

Energy consumption, remote condenser 72207.897 BTU/h chilling, 12059.091 BTU/h freezing / 7.5 HP RLA: 23.7 A / LRA: 107 A | MCA 34.725 A / MOP 58.425 A

Shipping

Shipping dimensions (W x D x H) Cabinet: 56.01" x 64.57" x 97.01" (142.3 x 164.0 x 246.4 cm)
Remote condenser: 44.09" x 58.27" x 48.43" (112.0 x 148.0 x 123.0 cm)

Approximate ship weight Cabinet: 816 lb (370 kg)
Remote condenser: 221 lb (100 kg)

NOTE: For indoor use only

Dimensional drawing

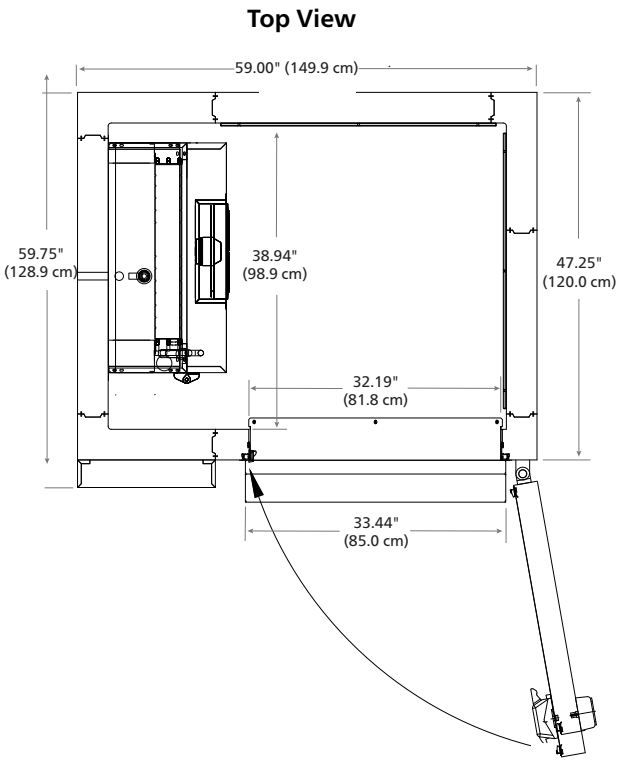
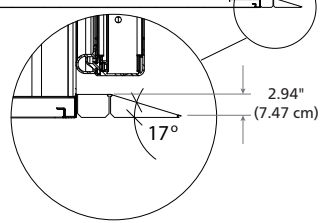
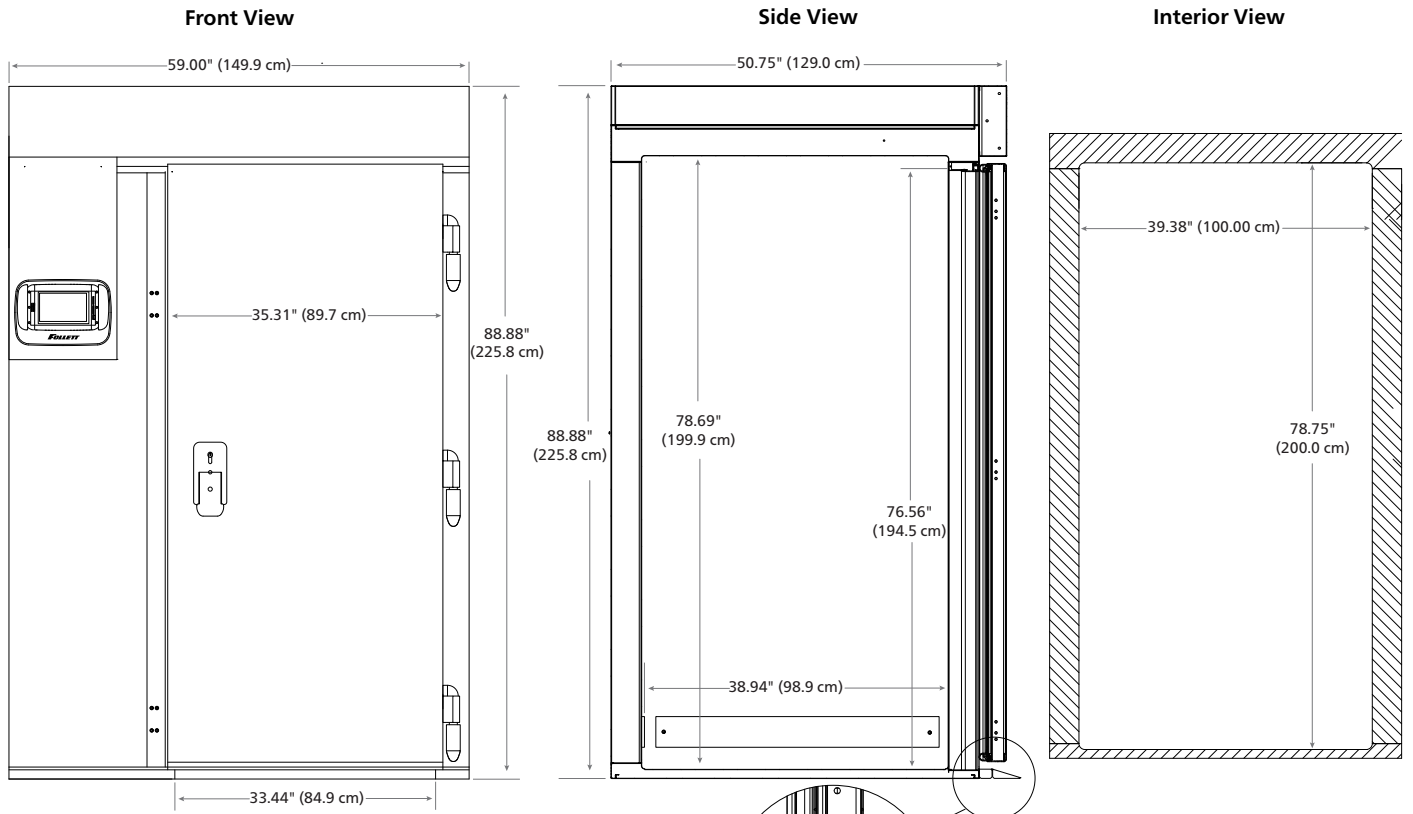

Remote Condensing Unit

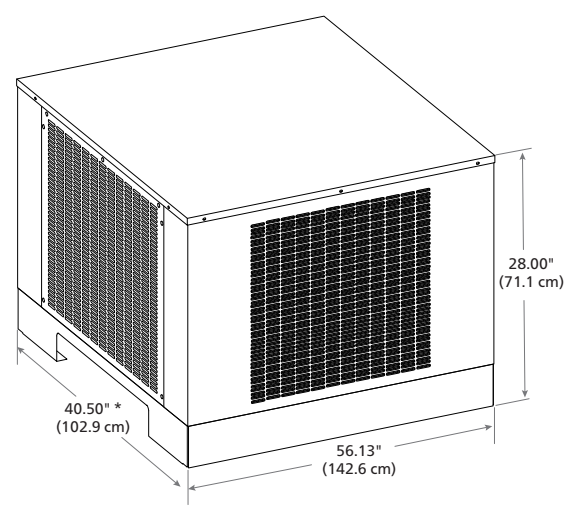

*Add 2.94" (7.47 cm) for fittings

FOLLETT is a registered trademarks of Follett Products, LLC, registered in the US.
Follett reserves the right to change specifications at any time without obligation.

1 Trolley roll-in blast chiller/shock freezer

1153-20260501 | © Follett Products, LLC

801 Church Lane | Easton, PA 18040, USA
1.800.523.9361 | 1.610.252.7301 | follettice.com

