

D1412R Horizon Elite™ Ice Machines (Remote Condensing)

Order parts online
www.follettice.com

Operation and Service Manual After Serial Number R03746

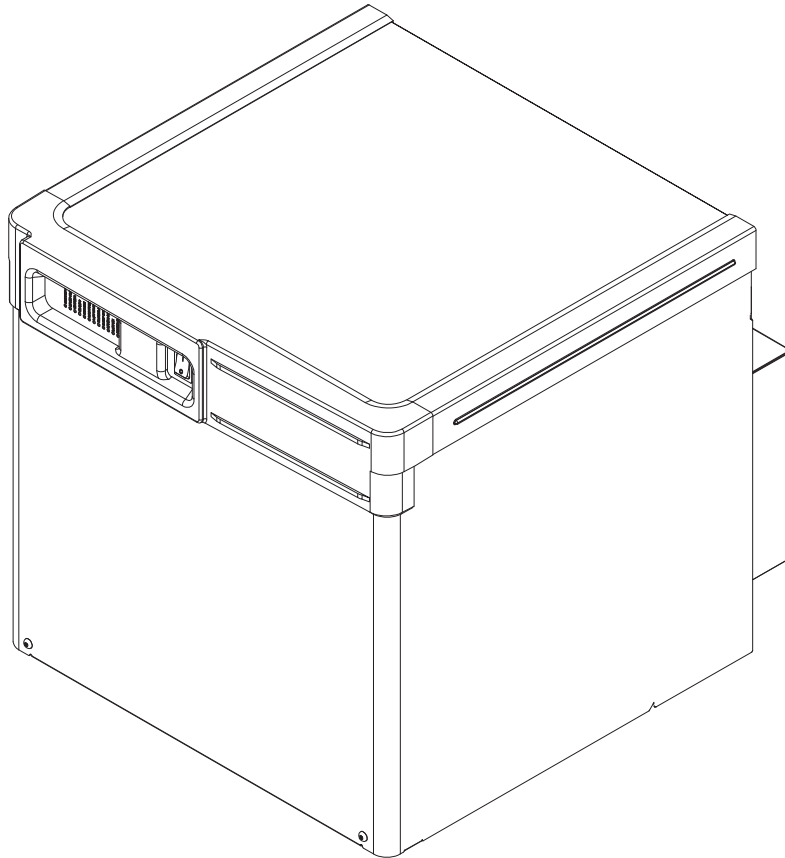

**Following installation, please forward this manual
to the appropriate operations person.**



801 Church Lane • Easton, PA 18040, USA
Toll free (877) 612-5086 • +1 (610) 252-7301
www.follettice.com

01519206R04

Contents

Welcome to Follett	4
Before you begin	4
Specifications	5
Electrical	5
Evaporator unit	5
Follett condensing unit	5
Evaporator plumbing	5
Flush drain plumbing	5
Chassis drain plumbing	6
Water Solenoid and Shut-off Valve	6
Ambient	7
Refrigeration	7
Weight	7
Ice production	7
Dimensions and clearances	8
Follett Condensing Unit	9
Operation	10
Cleaning/sanitizing and preventive maintenance (all models)	10
Service	14
Ice machine operation (all models)	14
“Bin full” detection system	16
Electrical system	17
Mechanical System	21
Evaporator disassembly	21
Evaporator reassembly	24
Refrigeration system	29
Refrigeration charge	31
Troubleshooting	32
Replacement parts	34
Evaporator assembly	34
Low-side assembly	36
Electrical box	38
Integration kit – top-mount and RIDE remote ice delivery	40
Skins assembly	42
1412 3-phase condensing unit	44
1412 3-phase condensing unit	45

Welcome to Follett

Follett equipment enjoys a well-deserved reputation for excellent performance, long-term reliability and outstanding after-the-sale support. To ensure that this equipment delivers the same degree of service, we ask that you review the installation manual (provided as a separate document) before beginning to install the unit. Our instructions are designed to help you achieve a trouble-free installation. Should you have any questions or require technical help at any time, please call our technical service group at (877) 612-5086 or +1 (610) 252-7301.

Before you begin

After uncrating and removing all packing material, inspect the equipment for concealed shipping damage. If damage is found, notify the shipper immediately and contact Follett Products, LLC so that we can help in the filing of a claim, if necessary.

Check your paperwork to determine which model you have. Follett model numbers are designed to provide information about the type and capacity of Follett equipment. Following is an explanation of the different model numbers in the series.

Chewblet® Ice Machine Model Number Configurations

Icemaker	Voltage	Series	Condenser	Application	Configuration
MC Maestro™ Chewblet® (425 Series)	C 208-230/60/1 (icemaking head) <i>Self-contained only.</i>	710 up to 675 lbs (306 kg)	A Air-cooled, self-contained W Water-cooled, self-contained	V Vision™ H Harmony™	S RIDE™ (RIDE remote ice delivery equipment)
HC Horizon Chewblet (710, 1010, 1410, 1810, 2110 Series)	D 115/60/1 (icemaking head) <i>Self-contained and remote. If remote unit, high side is 208-230/60/1.</i>	1010 up to 1061 lbs (482 kg)	R Air-cooled, remote condensing unit N Air-cooled, no condensing unit for connection to parallel rack system	B Ice storage bin J Drop-in M Ice Manager diverter valve system P Cornelius Profile PR150	T Top-mount
HM Horizon Micro Chewblet	E 230/50/1 (icemaking head) <i>Self-contained only.</i> F 115/60/1 (icemaking head) <i>Remote only. High side is 208-230/60/3.</i>	1410 up to 1466 lbs (665 kg) 1412 up to 1466 lbs (665 kg) 1810 up to 1790 lbs (812 kg) 2110 up to 2039 lbs (925 kg)	K Follett OCU required. Not compatible with rack system		

CAUTION

- Warranty does not cover exterior or outside installations.
- Moving parts. Do not operate with front cover removed.
- Hot parts. Do not operate with cover removed.
- To reduce risk of shock, disconnect power before servicing.
- Drain line must not be vented.
- Water supply must have particle filtration.
- Most ice machine cleaners contain citric or phosphoric acid, which can cause skin irritation. Read caution label on product and follow instructions carefully.
- Ice is slippery. Maintain counters and floors around dispenser in a clean and ice-free condition.
- Ice is food. Follow recommended cleaning instructions to maintain cleanliness of delivered ice.

Specifications

Electrical

Separate circuit and equipment ground required.

Evaporator unit

Standard electrical: 115/60/1
 Maximum fuse: 15A
 Amperage: 5A

Follett condensing unit – F1412CU

	Electrical	Min Circuit Ampacity	Max Circuit HVACR breaker size
1412 3-Phase (Emerson/Copeland)	208-230 V, 60 Hz	12A	20A

Evaporator plumbing

- 3/8" OD push-in water inlet (connection inside machine) - 3/8" OD tubing required.
- Water shut-off recommended within 10 feet (3 m).
- Follett recommends installation of Follett water filter system (part# 00130286) in ice machine inlet water line.

Flush drain plumbing

- 3/4" MPT flush drain connection at the rear of the machine.
- Drain must slope 1/4" inch per foot (6 mm per 30.4 cm).
- Drain line should not be shared with any other piece of equipment.
- Drain line cannot be reduced to a size smaller than 1 inch.
- Drain should be piped without a vent.

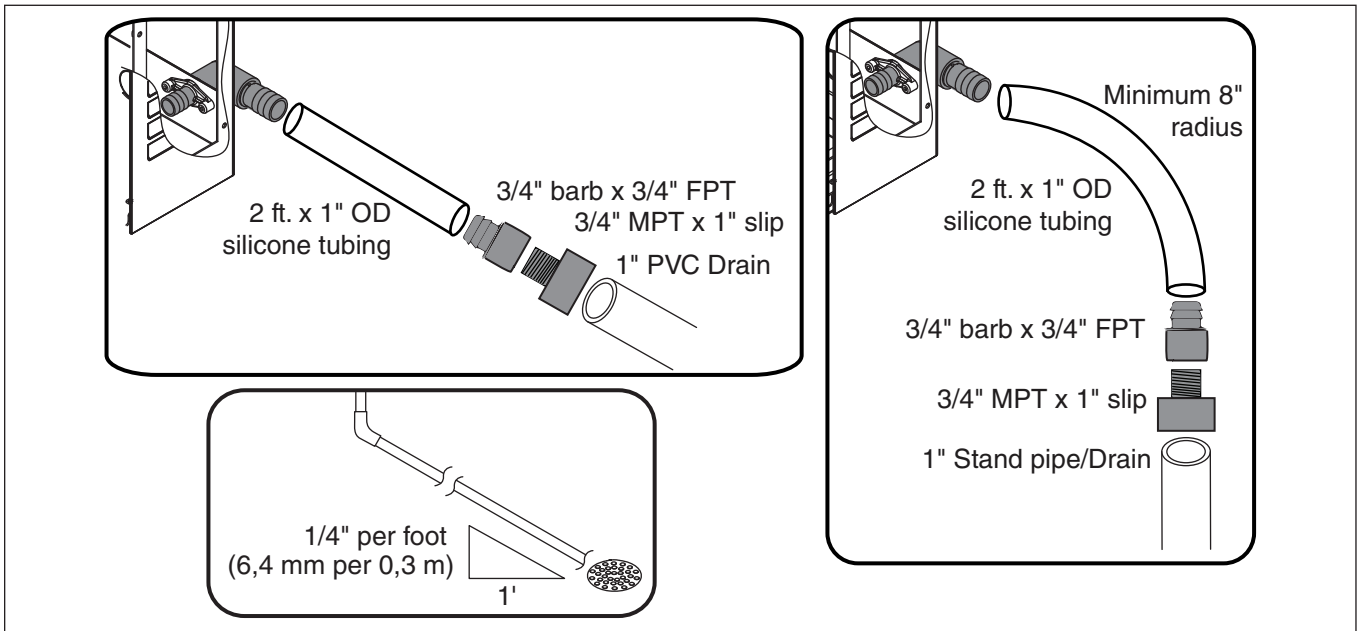

Chassis drain plumbing

- Plug must be removed from John Guest fitting.
- Route 3/8" drain tubing through knockout in back of docking station and insert fully into John Guest fitting connection at the rear of the machine chassis. Route other end of 3/8" drain tubing to drain.
- Drain must slope 1/4" inch per foot (6 mm per 30,4 cm).

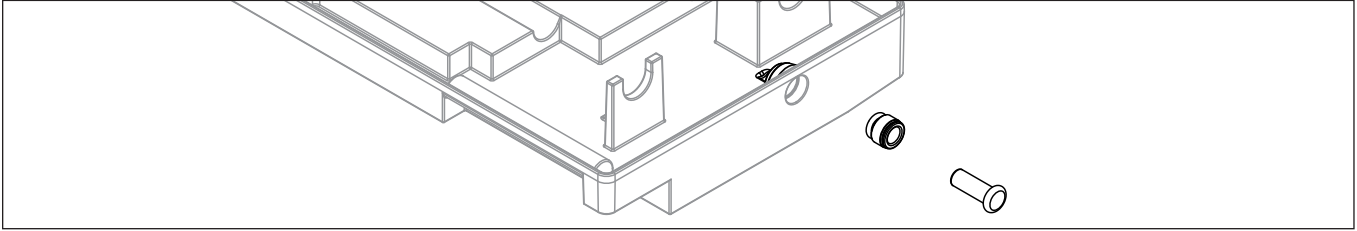

Water Solenoid and Shut-off Valve

Standard Installations

Mount water solenoid to inside rear of docking assembly using one screw **1**, insert potable water line into valve **2**, insert tubing into push-in connection of water solenoid **3**.

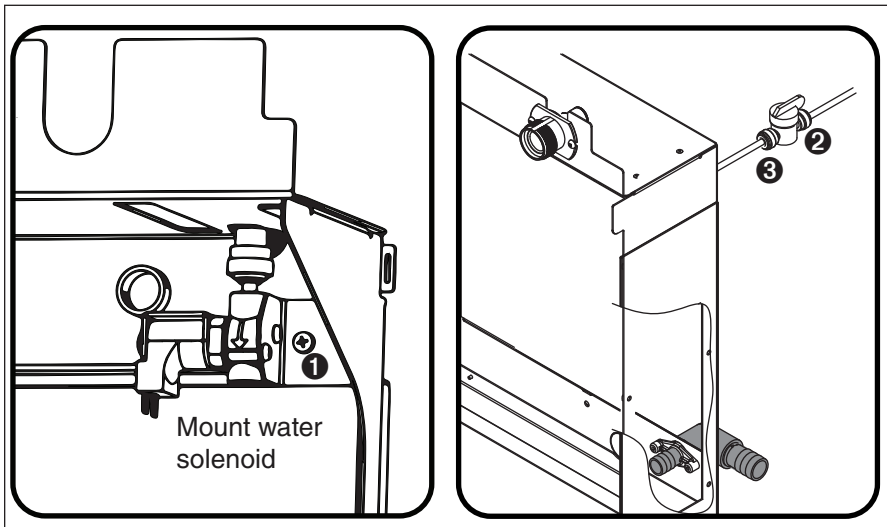

ATTENTION INSTALLER!

For undercounter installations only, the water inlet solenoid must be mounted on top of the evaporator **1**, its tubing connected to the water shut-off valve **2**, and the potable water line connected to the shut-off valve **3**. This method of installation provides access to the water shut-off valve for service or in case of an emergency.

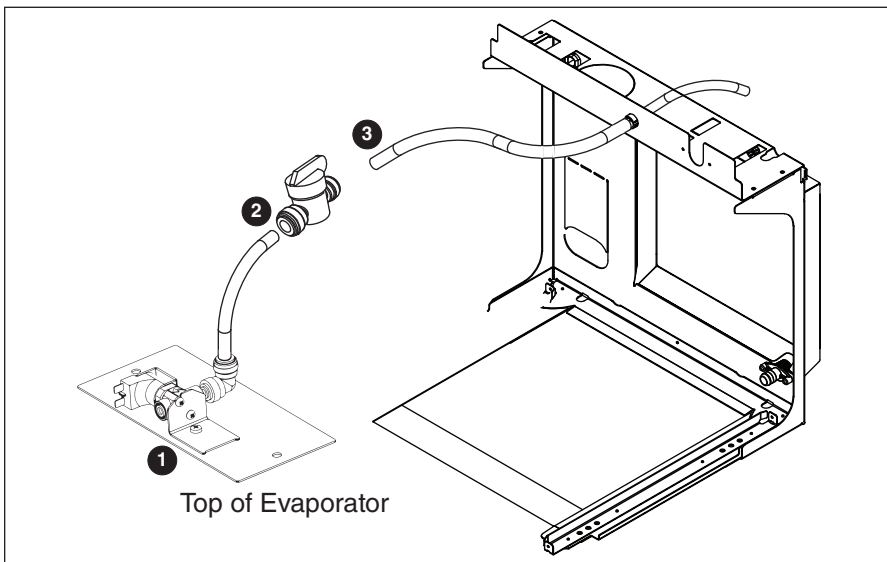

Ambient

Evaporator unit

Air temperature:	100 F/38 C max.	50 F/10 C min.
Water temperature:	90 F/32 C max.	45 F/7 C min.
Water pressure:	70 psi max. (483 kPa)	10 psi min. (69 kPa)

Condenser unit

Air temperature:	120 F/49 C max.	-20F/-29C min.
------------------	-----------------	----------------

Refrigeration

- R449A (unit fully charged with 8 lbs at factory)
- 3/8" liquid line
- 7/8" suction line

Note: 1412R not compatible with rack system. Consult Technical Service at 877-612-5086.

Weight

Evaporator unit: 125 lbs (57 kg)

Condensing unit:

Horizon Elite D1412 series	
Approximate ship weight	three phase – 265 lbs (120.2 kg)
Approximate net weight	three phase – 230 lbs (104.3 kg)

Ice production

D1412 ice machine capacity/24 hrs.

Ambient Air Temperature F/C							
Evap Potable Water Temperature F/C	F	60	70	80	90	100	
	C	16	21	27	32	38	
	50	1474	1372	1269	1212	1154	lbs
	10	669	623	576	550	524	kg
	60	1385	1292	1198	1148	1097	lbs
	16	628	586	544	521	498	kg
	70	1296	1212	1127	1083	1039	lbs
	21	588	550	511	492	472	kg
	80	1239	1155	1072	1030	988	lbs
	27	562	524	487	468	449	kg
	90	90	1181	1099	1017	976	lbs
	32	32	536	499	462	425	kg

Dimensions and clearances

- Entire front of ice machine must be clear of obstructions/connections to allow removal.
- 1" (26mm) clearance above ice machine for service.
- 1" (26mm) minimum clearance on sides.
- The intake and exhaust air grilles must provide at least 250 sq in (1615 sq cm) of open area.
- Air-cooled ice machines – 18" (458 mm) minimum clearance between discharge and air intake-grilles.

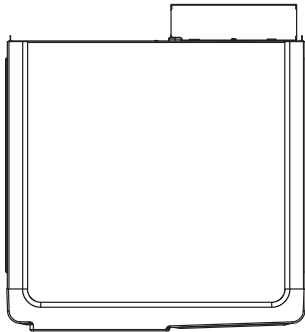

ICE-MAKER TOP VIEW

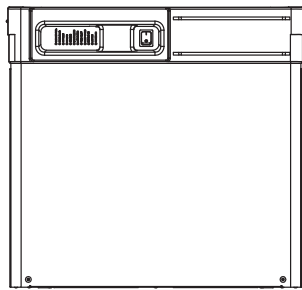
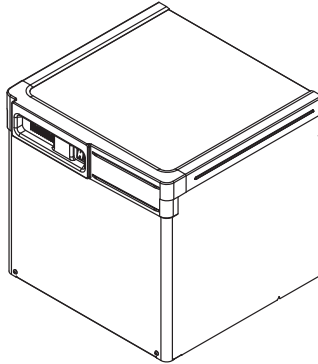

ICE-MAKER FRONT VIEW

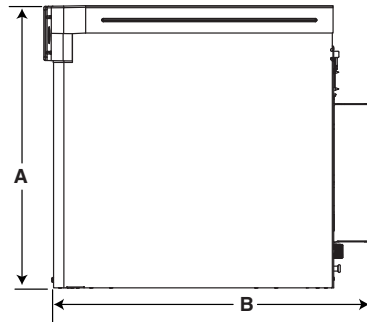

ICE-MAKER SIDE VIEW

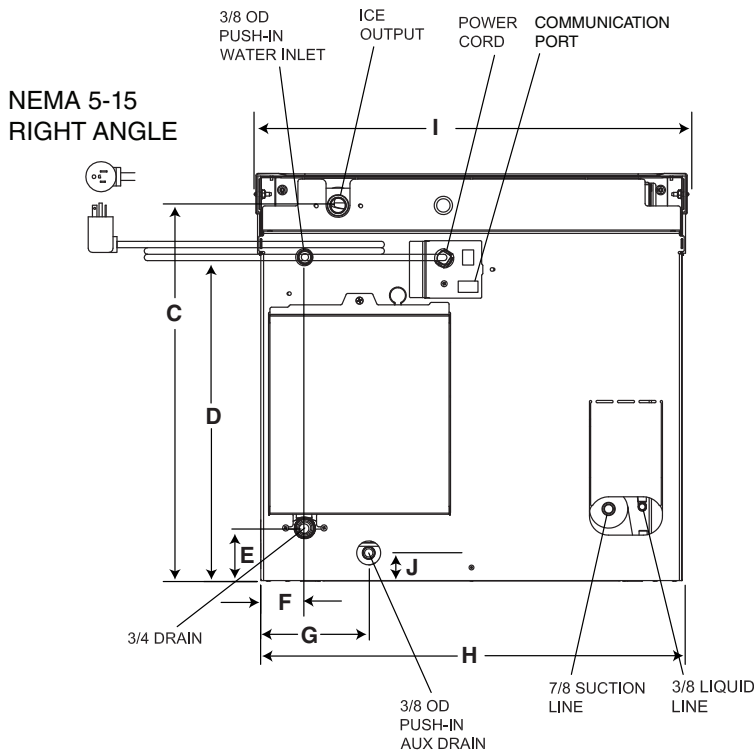

A	21.26" (54.0 cm)
B	24.59" (62.5 cm)
C	19.59" (49.8 cm)
D	16.92" (43.0 cm)
E	2.78" (6.9 cm)
F	2.28" (5.8 cm)
G	5.64" (14.3 cm)
H	22.00" (55.9 cm)
I	22.69" (57.6 cm)
J	1.48" (3.8 cm)

Follett Condensing Unit – F1412CU

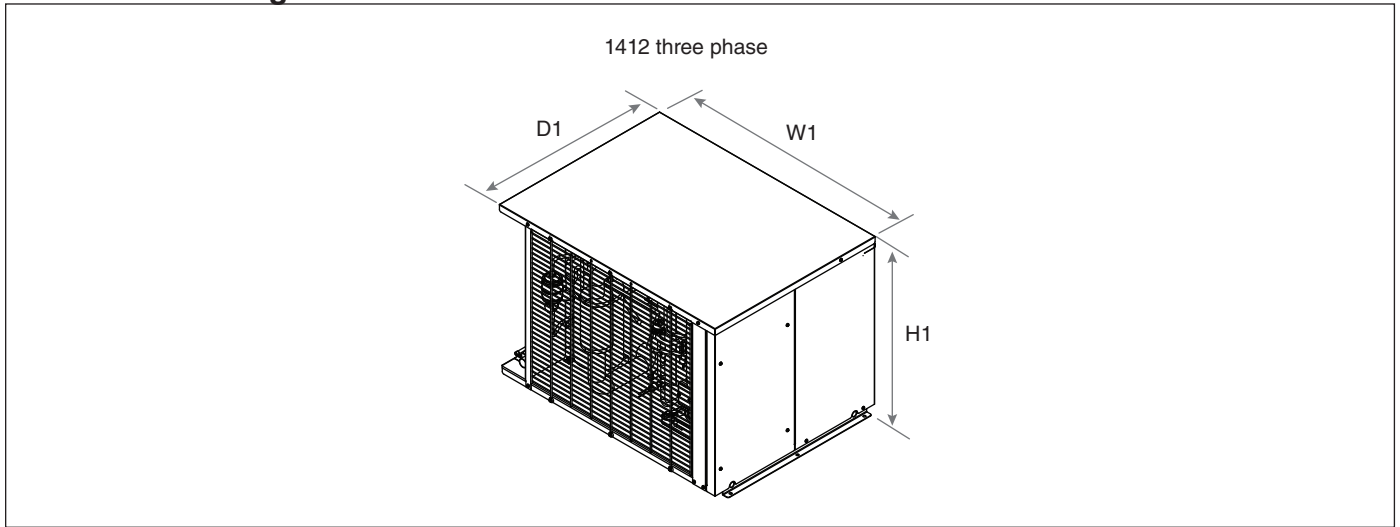

Horizon Elite 1412 series	
W1 Width	39.6" (100.6 cm)
D1 Depth	28.2" (71.6 cm)
H1 Height	26.0" (66.0 cm)
Electrical	three phase – 208-230/60/3 (Emerson/Copeland)
Minimum circuit ampacity	three phase – 12A
Maximum overcurrent protection	three phase – 20A
Outdoor condensing unit operating limits (air temperature)	min –20 F (–29 C) max 120 F (49 C)
Maximum refrigerant line run length	100' (30,5 m)
Maximum line rise above evaporator	35' (10,7 m)
Maximum refrigeration line drop without oil trap	15' (4,6 m)
Refrigerant charge	8 lb
Approximate ship weight	three phase – 265 lbs (120.2 kg)
Approximate net weight	three phase – 230 lbs (104.3 kg)

Operation

Cleaning/sanitizing and preventive maintenance (all models)

Note: Do not use bleach to sanitize or clean the icemaker.

Preventive maintenance

Periodic cleaning of Follett's icemaker system is required to ensure peak performance and delivery of clean, sanitary ice. The recommended cleaning procedures that follow should be performed at least as frequently as recommended, and more often if environmental conditions dictate.

Cleaning of the condenser can usually be performed by facility personnel. Cleaning of the icemaker system, in most cases, should be performed by your facility's maintenance staff or a Follett authorized service agent. Regardless of who performs the cleaning, it is the operator's responsibility to see that this cleaning is performed according to the schedule below. Service problems resulting from lack of preventive maintenance will not be covered under the Follett warranty.

Weekly exterior care

The exterior may be cleaned with a stainless cleaner such as 3M Stainless Steel Cleaner & Polish or equivalent.

Monthly condenser cleaning (air-cooled icemaker only)

1. Use a vacuum cleaner or stiff brush to carefully clean condenser coils of air-cooled icemakers to ensure optimal performance.
2. When reinstalling counter panels in front of remote icemakers, be sure that ventilation louvers line up with condenser air duct.

Semi-annual evaporator cleaning (every 6 months)

WARNING

- Wear rubber gloves and safety goggles (and/or face shield) when handling ice machine cleaner or sanitizer.

CAUTION

- Use only Follett approved SafeCLEAN Plus™ cleaning solution.
- DO NOT USE BLEACH.
- It is a violation of Federal law to use these solutions in a manner inconsistent with their labeling.
- Read and understand all labels printed on packaging before use.

Note: Complete procedure for cleaning and sanitizing MUST be followed. Ice must be collected for 10 minutes before putting ice machine back into service.

1. Note position of TDS switch. Set to HIGH for duration of cleaning. Press the CLEAN button. The machine will drain. The auger will run for a short time and then stop. Wait for the LOW WATER light to come on.

Fig. 1

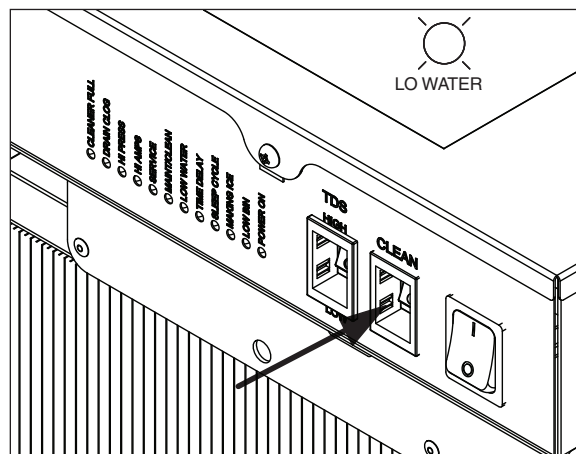

2. Follow the directions on the SafeCLEAN Plus packaging to mix 1 gal. (3.8 L) of Follett SafeCLEAN Plus solution. Use 120 F (49 C) water.
3. Using a 1 quart (1 L) container, slowly fill cleaning cup until CLEANER FULL light comes on and cleaner just begins to flow from the vent tube.
4. Place two SaniSponge™ cleaning sponges in remaining sanitizing and cleaning solution and retain for Step 9.

Note: Do not use bleach to sanitize or clean the icemaker.

Fig. 2

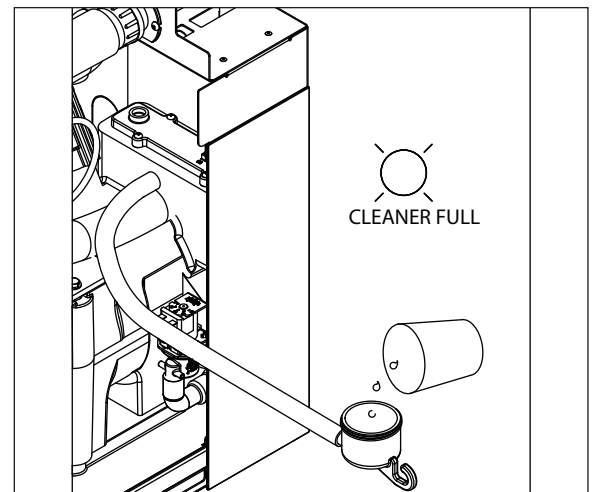

5. Replace cover on cleaner cup. Machine will clean, then flush 3 times in approximately 15 minutes. Wait until machine restarts.

Fig. 3

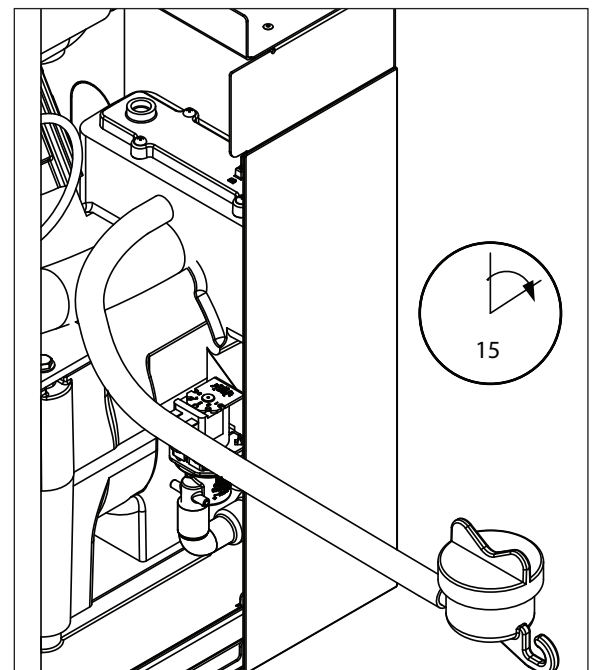

6. To clean/sanitize ice transport tube – Press power switch OFF

Fig. 4

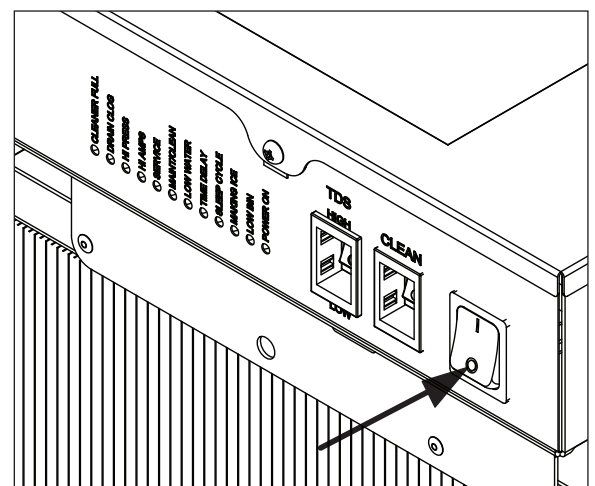

7. Disconnect coupling as shown.

Fig. 5

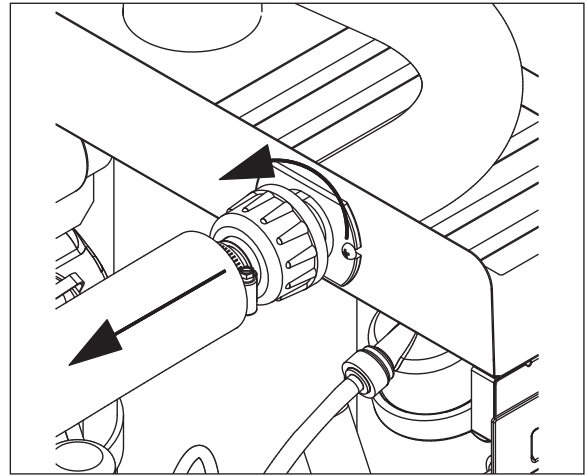

- 8. Using disposable foodservice grade gloves, insert both SaniSponge cleaning sponges saturated in SafeClean Plus (from Step 4).
- 9. Push both SaniSponge cleaning sponges down ice transport tube with supplied pusher tube.

Fig. 6

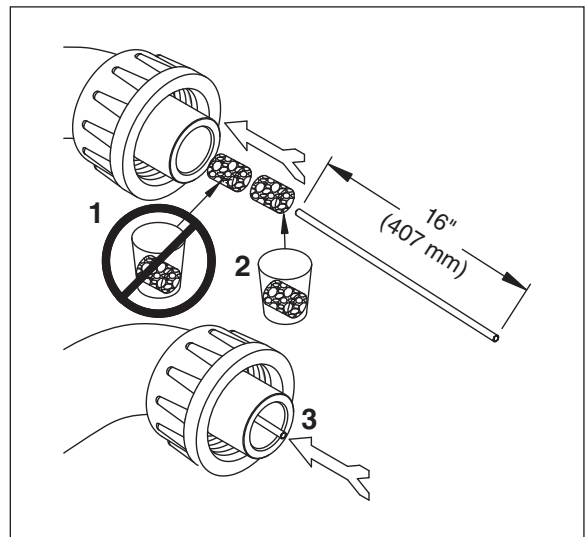

10. Remove and discard 16 inch (407 mm) pusher tube.

Fig. 7

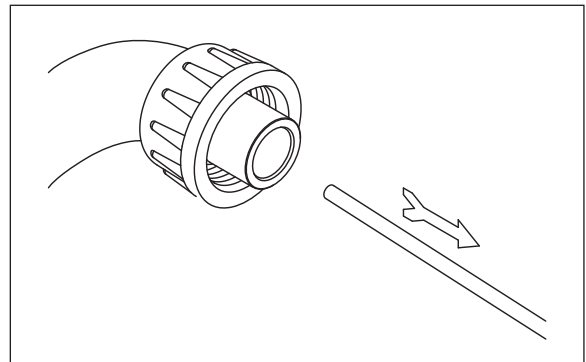

11. Reconnect coupling. Press power switch ON. Ice pushes SaniSponge cleaning sponges through ice transport tube.

Fig. 8

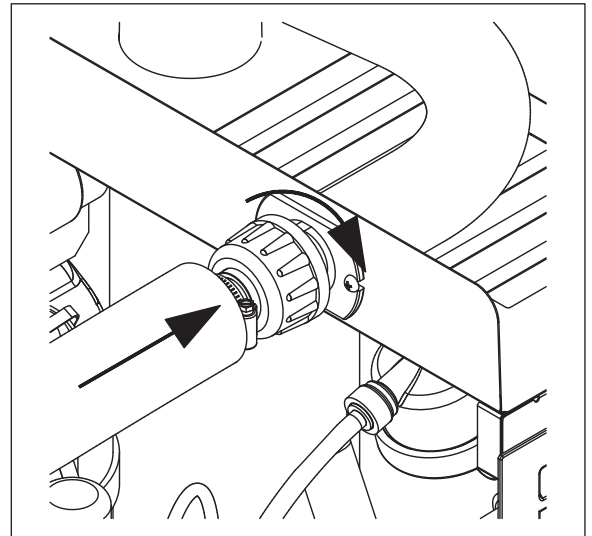

12. Place a sanitary (2 gal. or larger) container in bin or dispenser to collect SaniSponge cleaning sponges and ice for 10 minutes after the Sani-Sponges come out.
13. Discard ice and Sani-Sponges. Return TDS switch to the original position.

Fig. 9

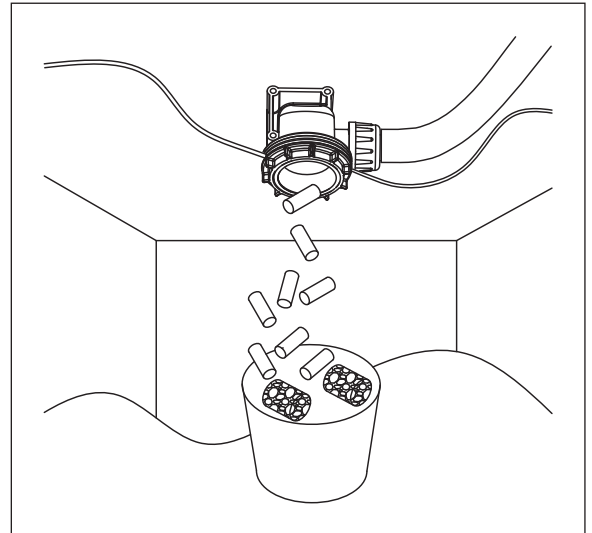

Service

Ice machine operation (all models)

Follett's ice machine consists of five distinct functional systems covered in detail as follows:

- Water system
- Electrical control system
- Mechanical assembly
- Refrigeration system
- Bin full

The Horizon ice machine overview

The Follett Horizon ice machine uses a horizontal, cylindrical evaporator to freeze water on its inner surface. The refrigeration cycle is continuous; there is no batch cycle. The evaporator is flooded with water and the level is controlled by sensors in a reservoir. A rotating auger (17 RPM) continuously scrapes ice from the inner wall of the evaporator. The auger moves harvested ice through the evaporator into an ice extrusion canal. The ice is forced through a restrictive nozzle that squeezes out the water and creates the Chewblet. The continuous extrusion process pushes the Chewblets through a transport tube into a dispenser or bin.

A solid state PC board controls and monitors the functionality of the ice machine. In addition to sequencing electrical components, the board monitors various operational parameters. A full complement of indicator lights allows visual status of the machine's operation. Additionally, the PC board controls the self-flushing feature of the ice machine. The evaporator water is periodically drained and replenished to remove minerals and sediment.

A unique "bin full" detection system is incorporated in the Horizon Elite ice machine. A switch located at the ice discharge port of the machine detects the position of the transport tube. When the bin fills up with ice, the transport tube moves out of the normal running position, and the switch turns the ice maker off. A domed housing at the end of the transport tube contains the ice extrusion loads during shut down.

Harvest system diagram

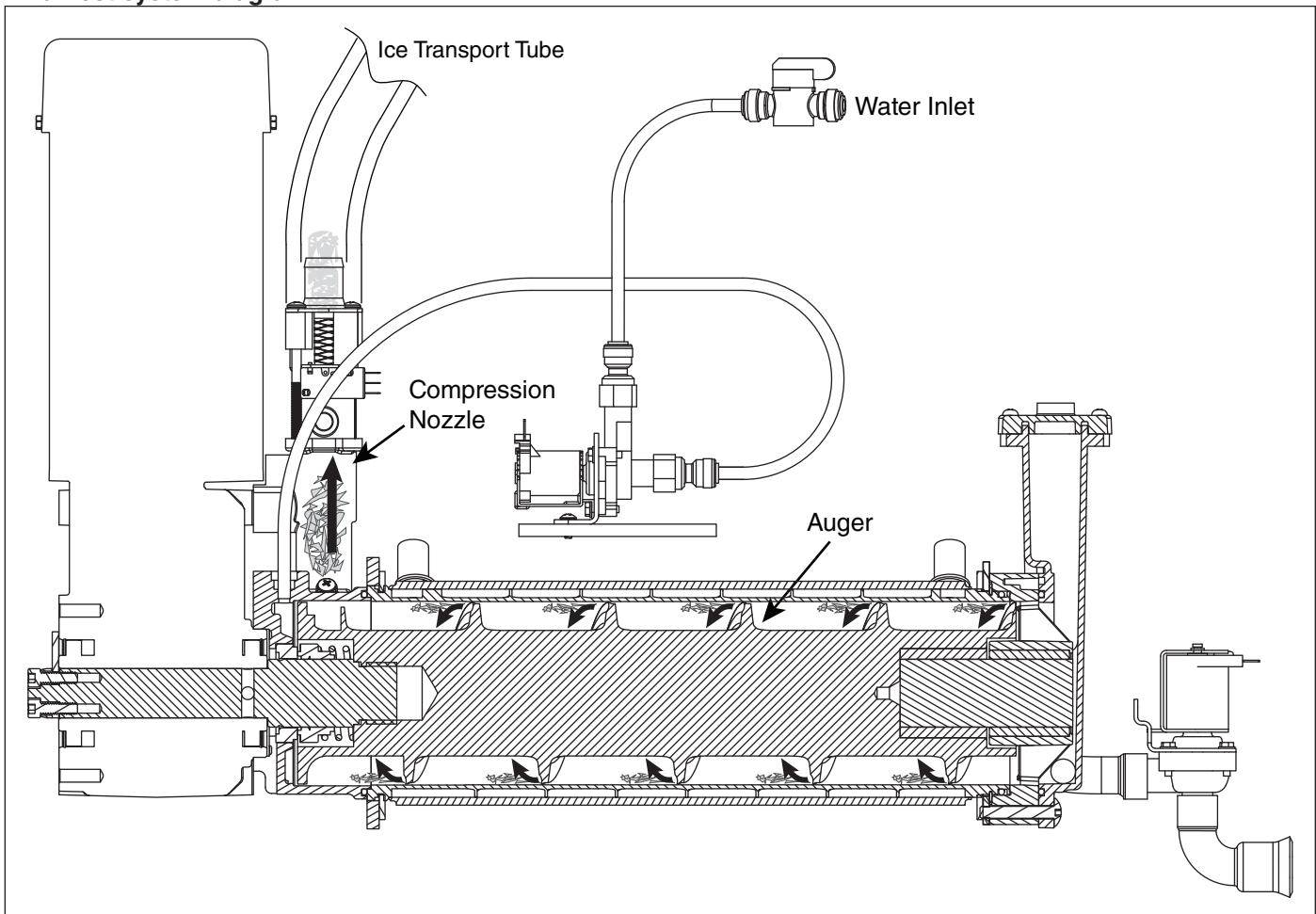

Water system

The water level in the evaporator is controlled by a feed solenoid and level detecting sensors. Referencing the diagram below, water sensing probes extend down into the reservoir at the end of the evaporator assembly. The system works via electrical conductivity as follows:

The probe labeled B is the common. When water is between any of the other probes and the common, the PC board will sense the activation. During normal operation, the water level rises and falls between the Normal High and Normal Low probes. As water is consumed to make ice, the level will fall until the Normal Low probe is exposed, triggering the water feed solenoid on. Water will fill until the Normal High sensor is activated.

Note: The potable water total dissolved solids (TDS) content must be greater than 10 ppm for the water control system to function properly. If using reverse osmosis water filtration system, ensure TDS level is greater than 10 ppm.

Water system diagram

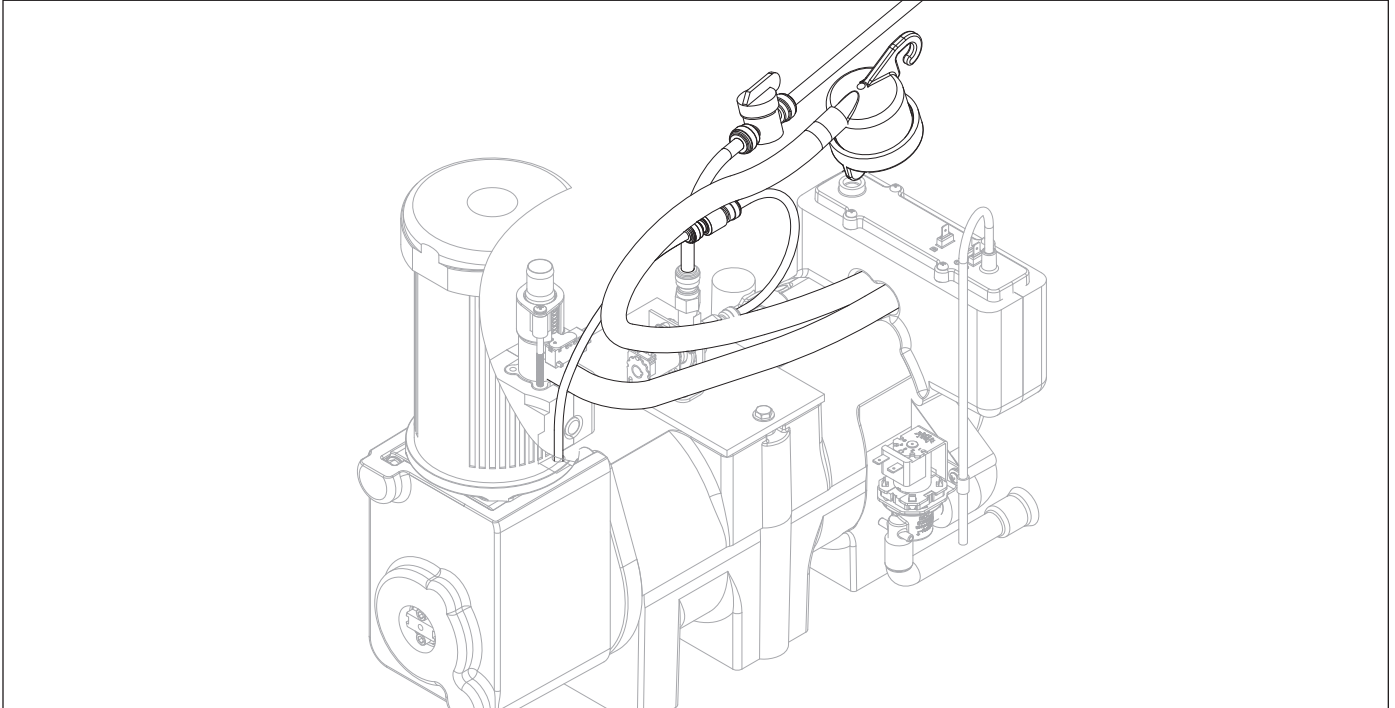

Water level diagram

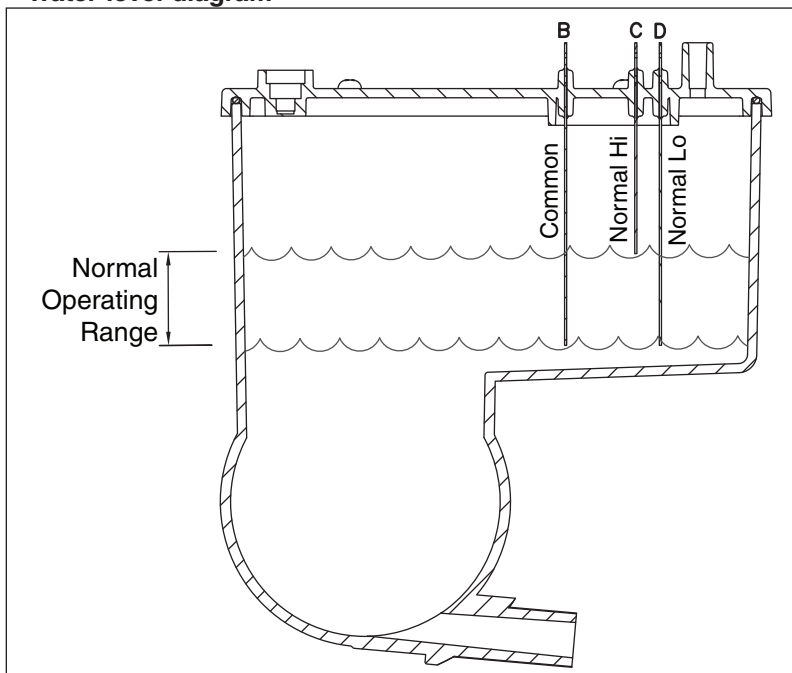

“Bin full” detection system

The Follett Horizon ice machine incorporates a unique “bin full” detection system that consists of the shuttle and actuator. The shuttle incorporates a flag and switch. Referencing the figure below, the normal running position of the flag is down, and the switch is closed. When the bin fills to the top and ice can no longer move through the tube, the machine will force the shuttle flag up, opening the switch and shutting the machine off. The shuttle actuator, located above the ice bin allows the ice to curl up within it when the bin is full. In this way, there are no loads generated that would tend to lift off the lid of the bin. Do not apply voltage, this system works on contact closure only.

Shuttle flag and sensor

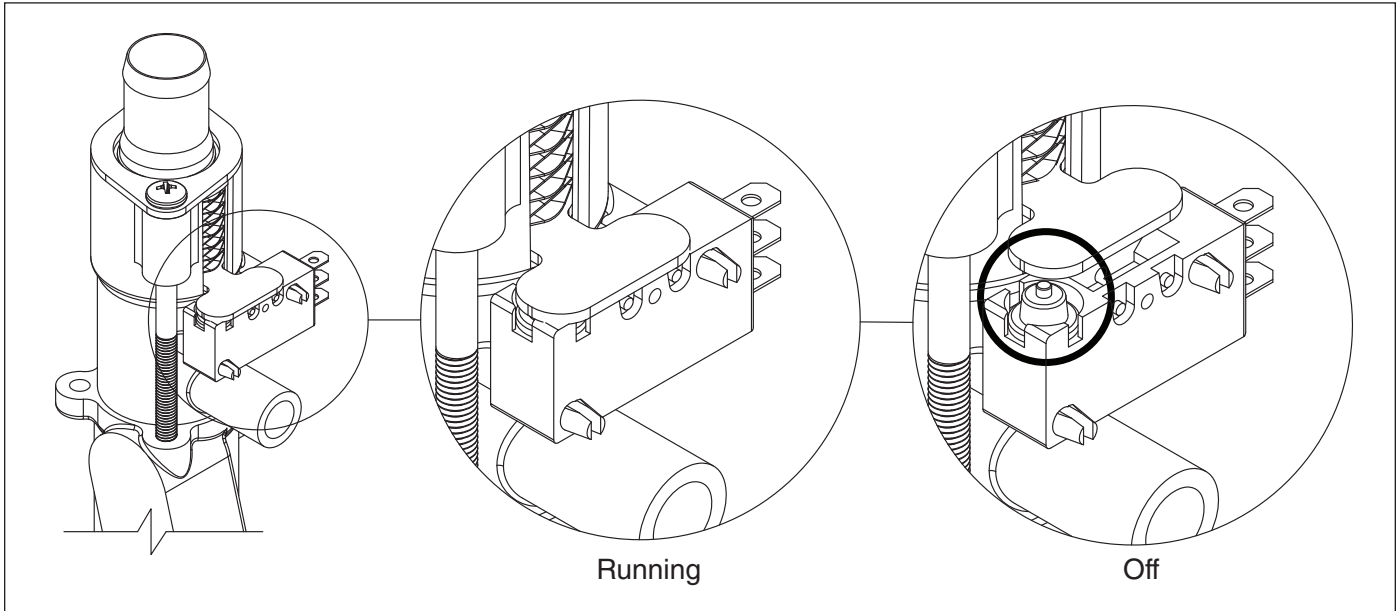

Shuttle actuator

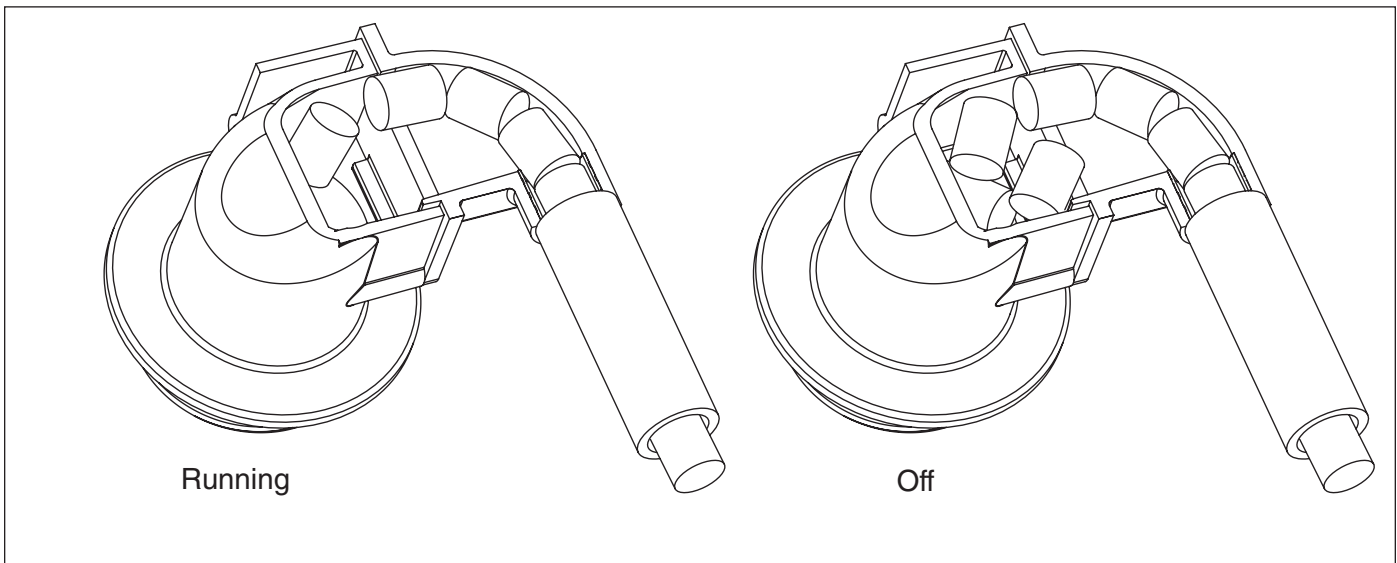

Electrical system



ATTENTION!

To prevent circuit breaker/Hi-amp overload, wait 5 minutes before restarting this unit. This allows the compressor to equalize and the evaporator to thaw.

Normal control board operation

The PC board indicator lights provide all the information necessary to determine the machine's status. Green indicator lights generally represent “go” or normal operation; Yellow indicators represent normal off conditions; Red indicators generally represent alarm conditions, some of which will lock the machine off.

A flashing green light labeled POWER indicates power to the machine. All other normal operation status indicators are covered as follows:

Ice machine disposition	Operating conditions
Legend: ● ON ○ OFF ◐ ON or OFF ◑ FLASHING	
1. Ice machine is making ice. CLEANER FULL ○ DRAIN CLOG ○ HI PRESS ○ HI AMPS ○ SERVICE ○ MAINT/CLEAN ○ LOW WATER ○ TIME DELAY ○ NOT USED ○ MAKING ICE ● LOW BIN ● POWER ON ◑	1. Normal running.
2. Ice machine is not making ice. CLEANER FULL ○ DRAIN CLOG ○ HI PRESS ○ HI AMPS ○ SERVICE ○ MAINT/CLEAN ○ LOW WATER ● TIME DELAY ○ NOT USED ○ MAKING ICE ○ LOW BIN ◐ POWER ON ◑	2. Normal time delay. When the bin fills with ice, the LOW BIN light goes out momentarily and the refrigeration and auger drive systems immediately shut down. (Note: The fan motor will continue to run for 10 minutes to cool condenser) The TIME DELAY light comes on, initiating the time delay period. When the time delay expires, the machine will restart provided that the LOW BIN light is on.

DIP Switch Settings

	OFF	ON	
SET TO OFF	<input checked="" type="checkbox"/>	<input type="checkbox"/>	1 NOT USED
SET TO OFF	<input checked="" type="checkbox"/>	<input type="checkbox"/>	2 NOT USED
SET TO OFF	<input checked="" type="checkbox"/>	<input type="checkbox"/>	3 NOT USED
SET TO OFF	<input checked="" type="checkbox"/>	<input type="checkbox"/>	4 NOT USED
SET TO OFF	<input checked="" type="checkbox"/>	<input type="checkbox"/>	5 NOT USED
IMDV	<input checked="" type="checkbox"/>	<input type="checkbox"/>	9 IMDV-2CM and all other applications
Flush disabled	<input checked="" type="checkbox"/>	<input type="checkbox"/>	7 Flush enabled
Maintenance timer ON	<input checked="" type="checkbox"/>	<input type="checkbox"/>	8 Maintenance timer OFF

Error faults:

The Horizon PC board monitors various operating parameters including high pressure, auger gearmotor amperage limits, clogged drain, and low water alarm conditions.

- Errors will automatically reset after the 1 hour time delay or can be reset by cycling power.

HI AMPS: The PC board monitors the amperage of the auger motor. Should the gear motor experience current draw above the allowable limit (or a current draw reading of 0.0A on the P4 terminal), the machine will shut down and the TIME DELAY and HI AMP will be illuminated. After the time delay the machine will restart and the TIME DELAY and HI AMP will clear.

LOW WATER: During operation, the water level cycles between the normal low and normal high sensors. Should the water be shut off to a running machine, a soft error will occur. The error sequence is as follows: During operation, the water level falls to the normal low sensor, and when it does the water feed solenoid is energized. If water is not detected at the normal low sensor within 30 seconds, a soft error will occur. The machine will shut down on a low water/time delay error. Should water return, it will fill to the normal low sensor and the machine will resume operation once the 1 hour time delay expires.

FLASHING LOW WATER: During normal production if the ice machine does not call for water in 5 minutes, the Low Water light will begin to blink indicating the unit is not consuming the water that is in the reservoir.

HI PRESSURE (self-contained only): Should the refrigeration pressure rise above 425 psi, the machine will shut down and the TIME DELAY and HIGH PRESSURE will be illuminated. After the time delay, and if the pressure has fallen back below the reset point of 295 psi, the machine will restart and the TIME DELAY and HIGH PRESSURE will clear.

SERVICE: The water leak sensors (black and purple wires), located in the chassis will detect the presence of water just below the top edge of the chassis.

DRAIN CLOG: When the machine shuts down on a full bin, the machine will purge. During this purge, if water does not get below the low probe in the reservoir within 20 seconds, the Drain Clog LED will light. The machine will continue to run but this is an indication of a poorly draining machine and must be addressed.

Relay output indication:

Each relay on the board has an indicator light associated with its output. For example, when the relay for the water feed solenoid is energized, the adjacent indicator light glows green.

Evaporator flushing sequence (TDS should be set to HIGH unless otherwise instructed by Follett):

During operation, the purge solenoid will open in order to drain water. There are two drain settings to choose from: High TDS or Low TDS. (There is a rocker switch behind the front cover of the machine.) The intent is to drain the Total Dissolved Solids from the machine while it makes ice.

While ice is being made, the TDS of the water in the evaporator increases in TDS concentration. Without periodic draining, the TDS levels will climb to very detrimental levels, levels that will cause scale to form and cause poor machine operation. The Low TDS setting will allow the machine to operate for one hour before going through the flushing sequence; the High TDS setting will allow the machine to run for 10 minutes before going through the flushing sequence.

The flushing sequence toggles the purge and fill solenoids three times. That is, the purge solenoid will energize until the water level drops below the low probe. The fill solenoid then energizes until water reaches the high probe, and so on for 3 cycles.

Typically, High TDS might be considered levels above 200 PPM, but local experience and varying water chemistry may compel a High TDS setting for best performance in even lower TDS levels.

Wiring diagram, evaporator unit

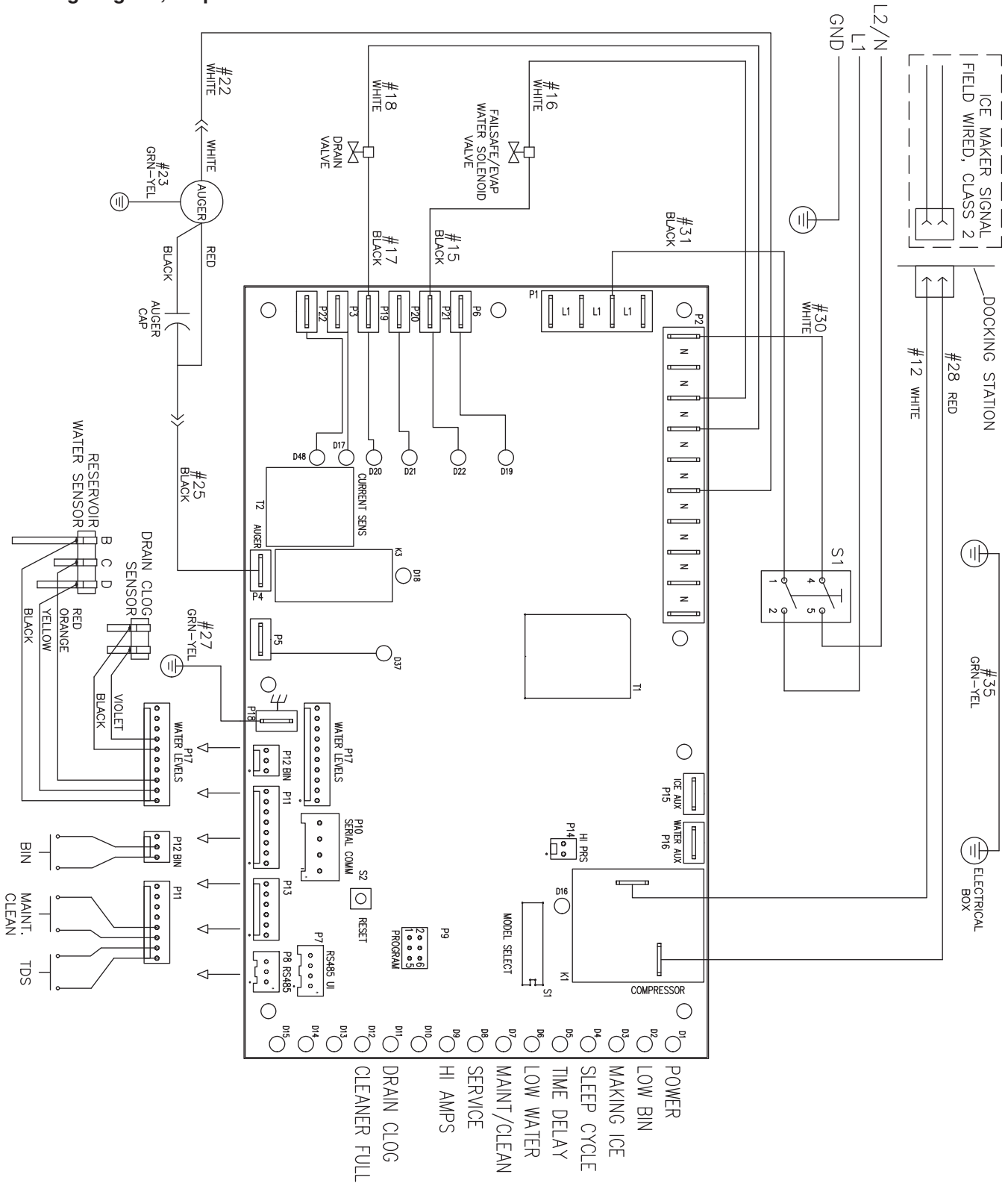

Gearmotor data

Gearmotor current 2.8A @ 115 V
 Gearmotor torque-out (high amp) trip point: 5.6A

Resistance of windings

115 vac gearmotor (Brother):
 White to Black: 3Ω
 White to Red: 3Ω
 Red to Black: 6Ω

1412 Three-phase condensing unit wiring diagram

F1412CU

3-PHASE, 208-230 VAC

OUTDOOR CONDENSING UNIT

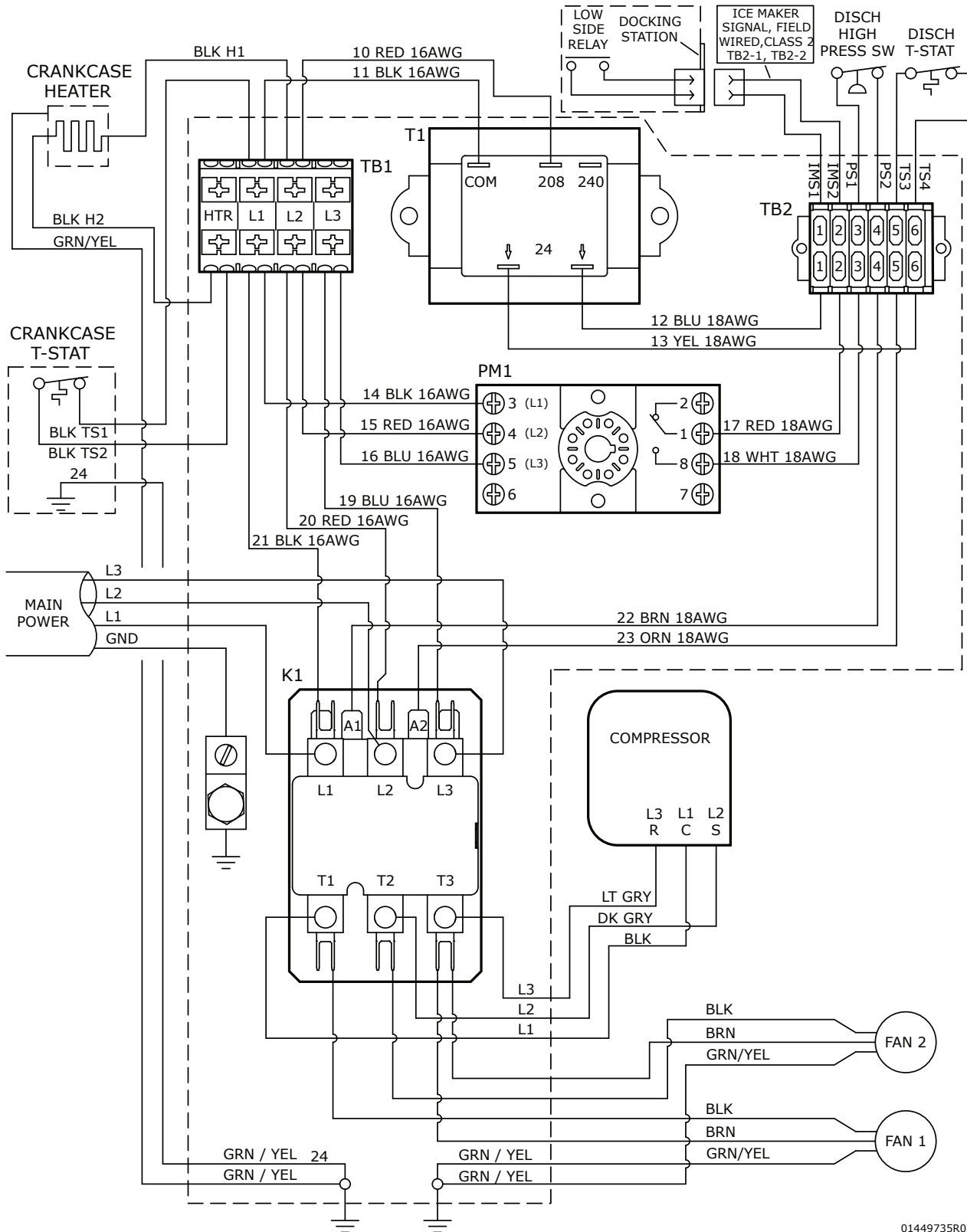

01449735R03

Mechanical System

Evaporator disassembly

1. Press CLEAN button to purge evaporator. Turn power OFF when LO WATER lights.
2. Unscrew and disconnect transport tube from louvered docking assembly.

Fig. 10

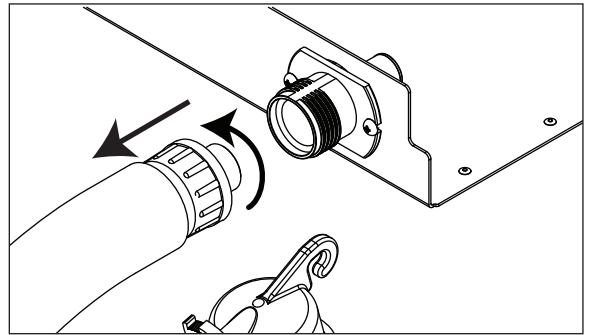

3. Remove gearbox insulation..

Fig. 11

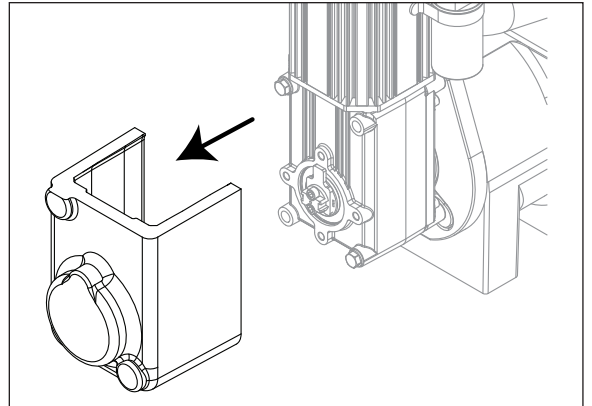

4. Disconnect gear motor wires.

Fig. 12

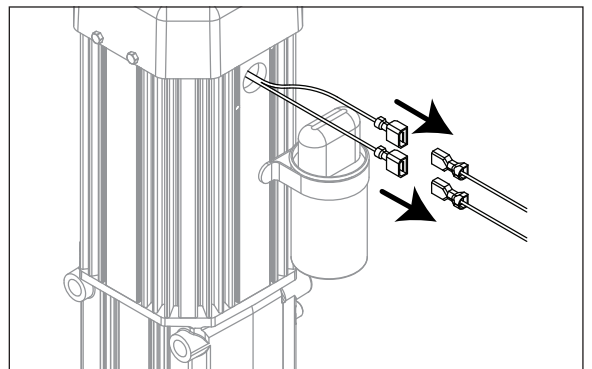

5. Remove screws (with 3/16" allen wrench) and auger retaining fork:

Fig. 13

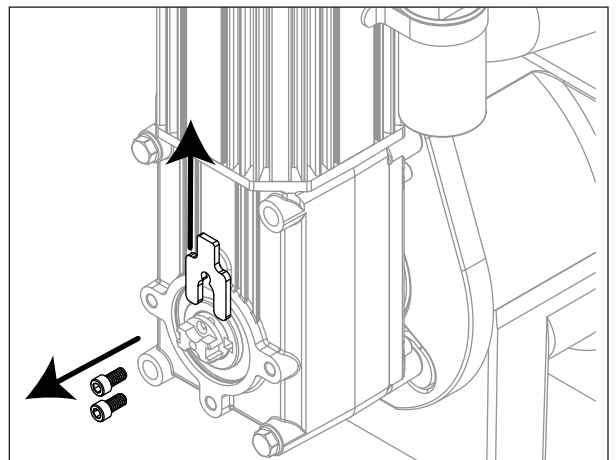

- 6. Remove gear motor bolts (9/16" wrench).
- 7. Remove gear motor and wipe auger shaft clean.

Fig. 14

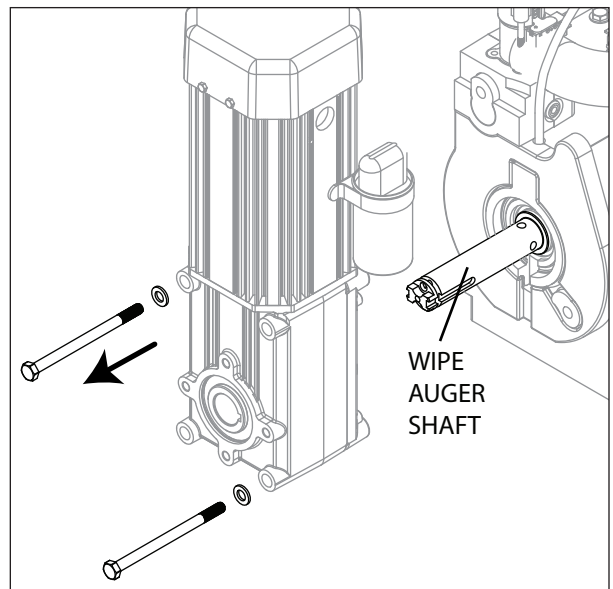

- 8. Remove main housing insulation and shuttle insulation:

Fig. 15

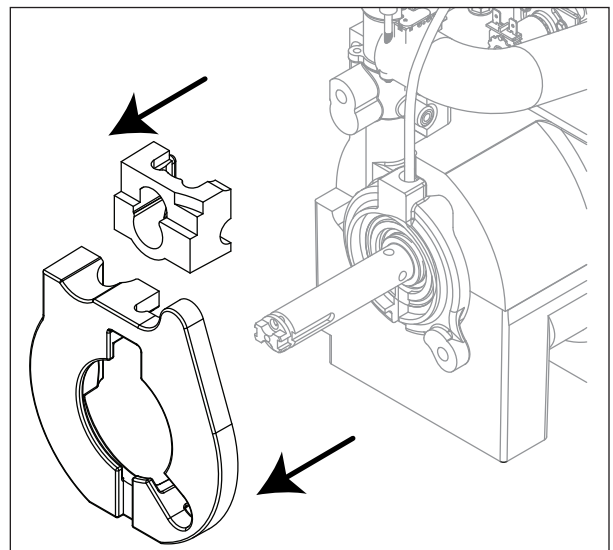

- 9. Remove front feed water tube from push-in fitting, shuttle drain tube, and shuttle switch.

Fig. 16

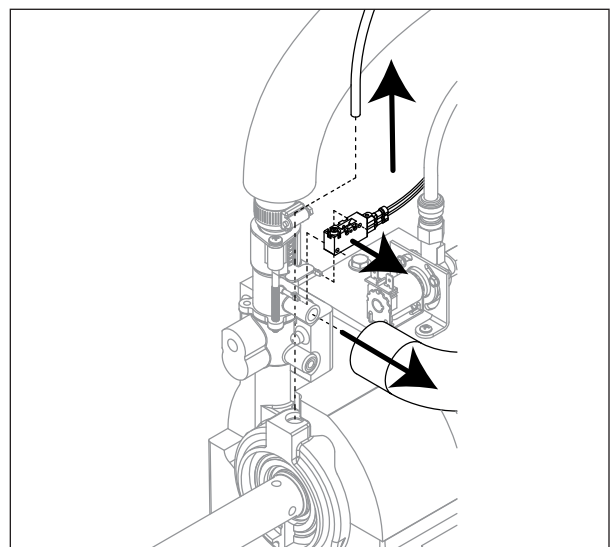

10. Remove 3 screws (with 3/16" allen wrench) then remove auger and main housing together.

Note: Auger is sharp - wear protective gloves.:

Fig. 17

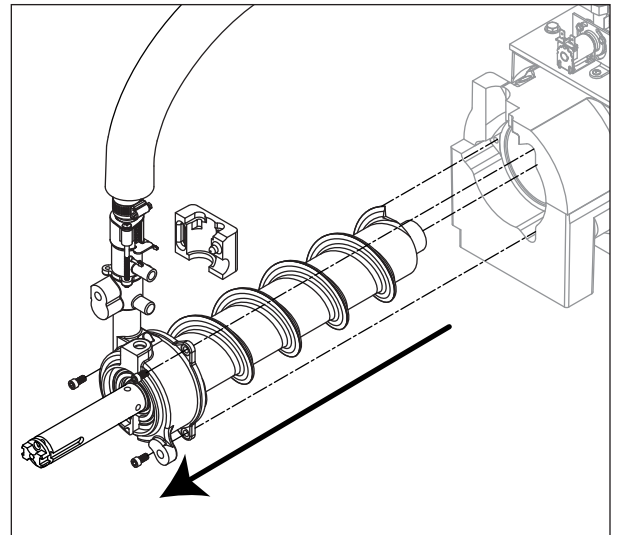

11. Rotate auger to align opening in auger flange with stream divider.
12. Pull out auger.:

Fig. 18

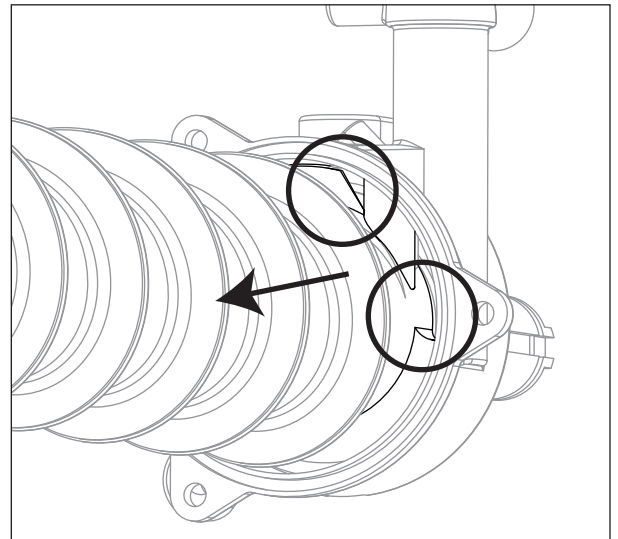

13. Remove and discard the ceramic mating ring and shaft seal.

Fig. 19

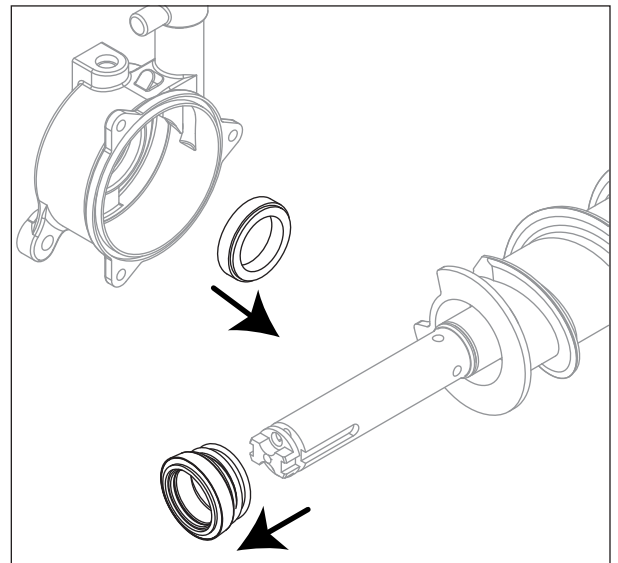

Evaporator reassembly

14. Install ceramic mating ring and shaft seal.

Caution: Do not touch the sealed surface of either part. Oil from bare skin will cause premature seal failure. Do not use petrol-gel on shaft seal.

15. Use liquid hand soap on the rubber part of the ceramic seal when installing in main housing. Use supplied cardboard disc to press into recess.
16. Apply liquid hand soap to raised area of auger shaft and interior rubber portion of shaft seal before installing seal.
17. Clean O ring groove. Lubricate O ring with petrol-gel and reinstall.

Fig. 20

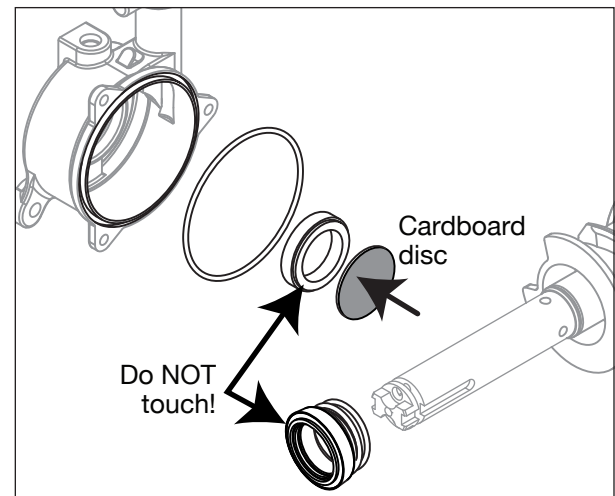
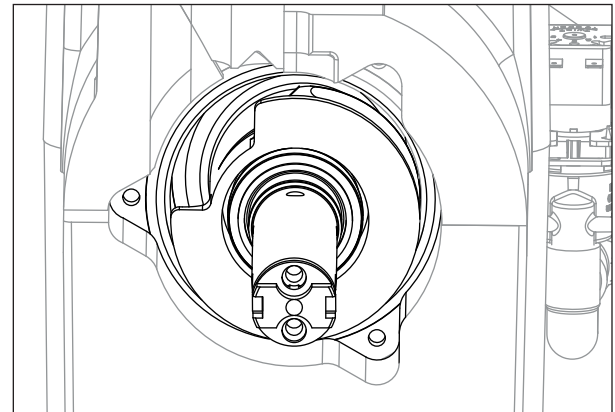

Fig. 21



18. Carefully install auger.
19. Rotate auger to position shown to clear main housing stream divider.

Fig. 22

20. Install rear shuttle insulation (Fig. 22.1) and slide main housing (Fig. 22.2) onto auger.
21. When installing new water seal, use screwdriver to compress the spring (Fig. 22.3), which allows for easier installation of the three screws.

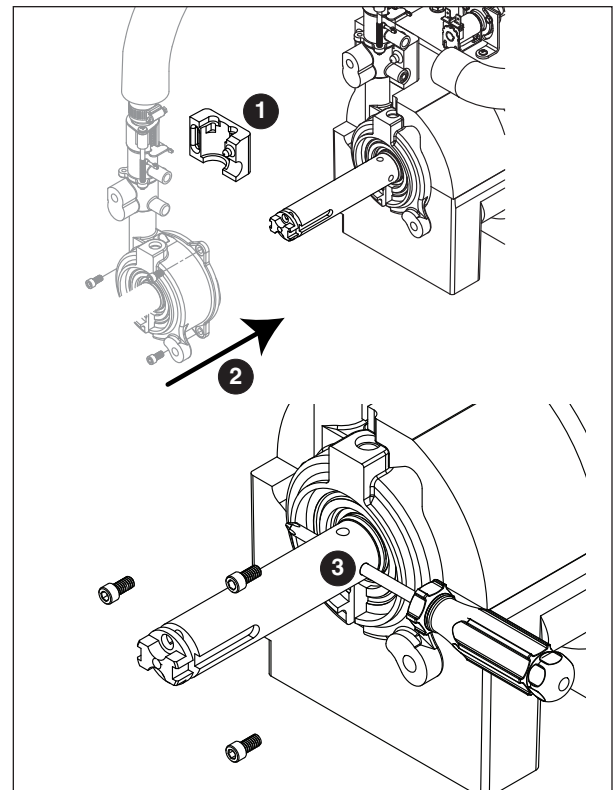

22. Install shuttle switch.

- Align holes with pins (Fig. 23.1) and depress switch button (Fig. 23.2) to clear shuttle tab.

Fig. 23

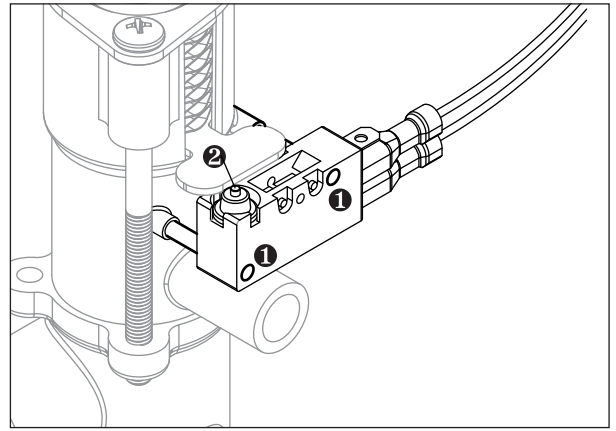

23. Install shuttle drain tube and front feed water tube (Fig. 24).

Fig. 24

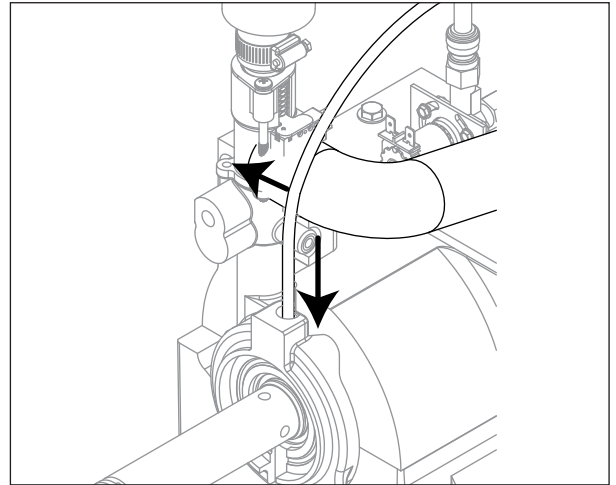

- 24. Install main housing insulation and shuttle insulation:**
25. Apply a coat of food safe grease to auger shaft.

Fig. 25

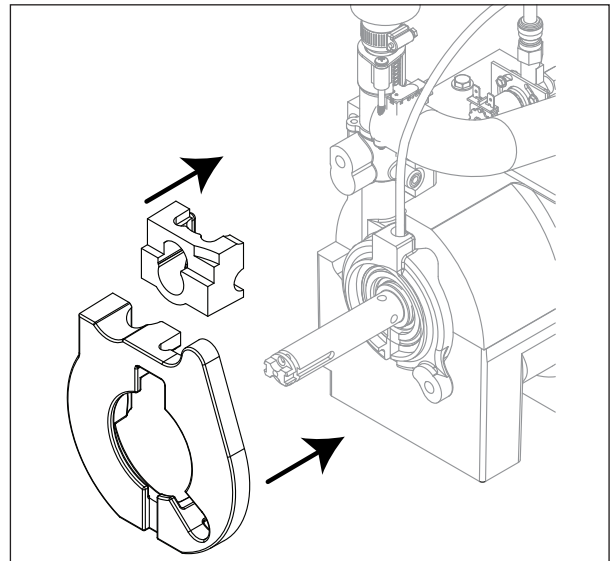

26. Slide gear motor onto auger and install gear motor bolts (9/16" wrench).

Fig. 26

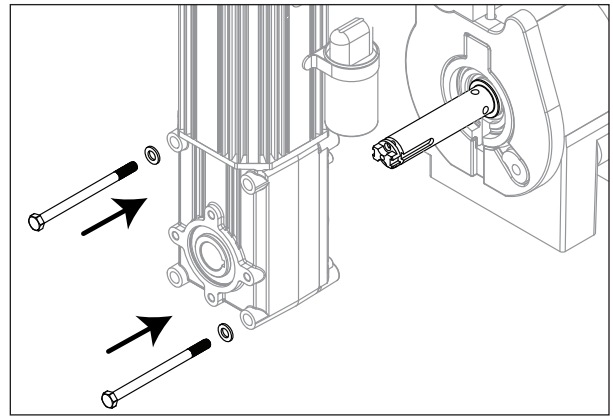

27. Connect gear motor wires.

Fig. 27

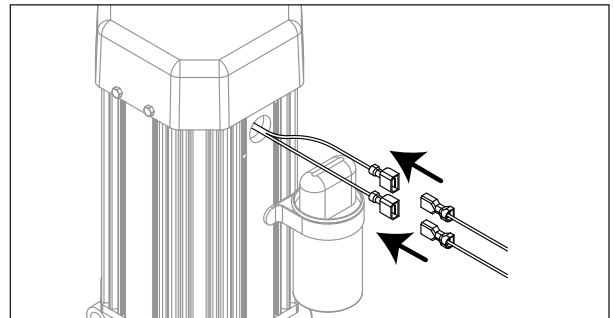

28. Pry auger forward and rotate auger using 1/2" wrench to align keyways.

Fig. 28

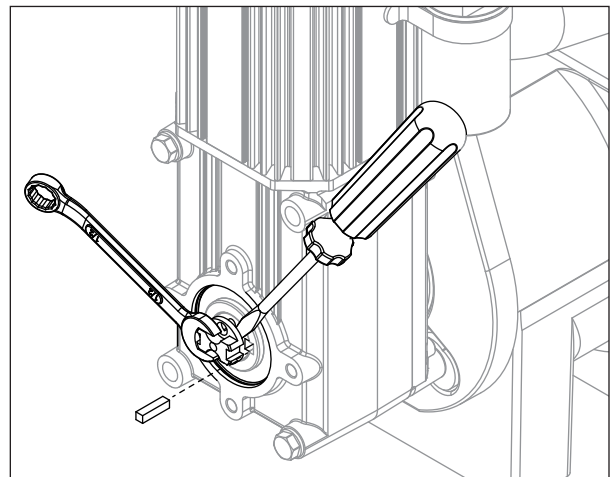

29. Insert key fully.

Fig. 29

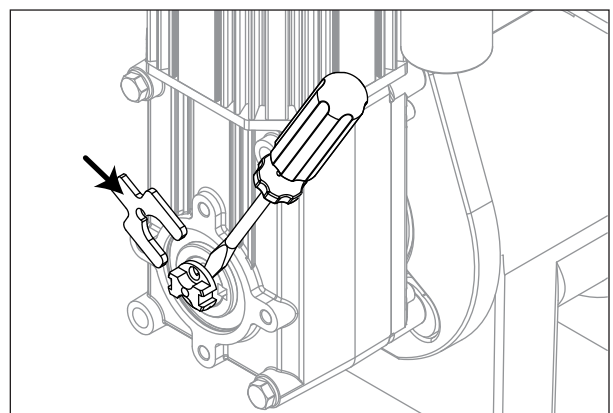

30. Pry shaft forward to install retainer fork.

- 31. Rotate retainer fork to align screw holes.
- 32. Install screws to secure retainer fork.

Fig. 30

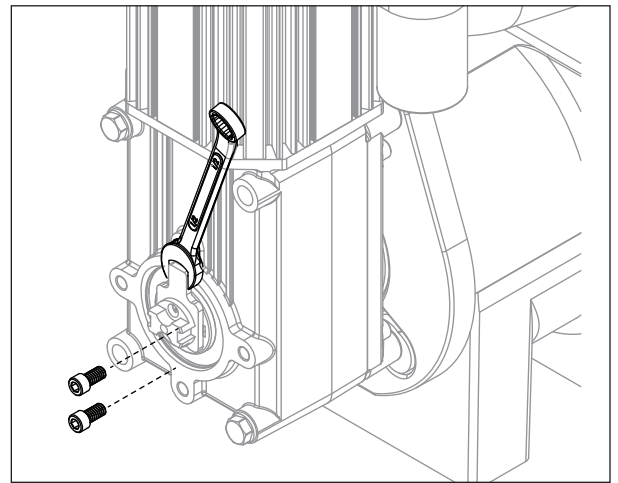

- 33. Install gearbox insulation.

Fig. 31

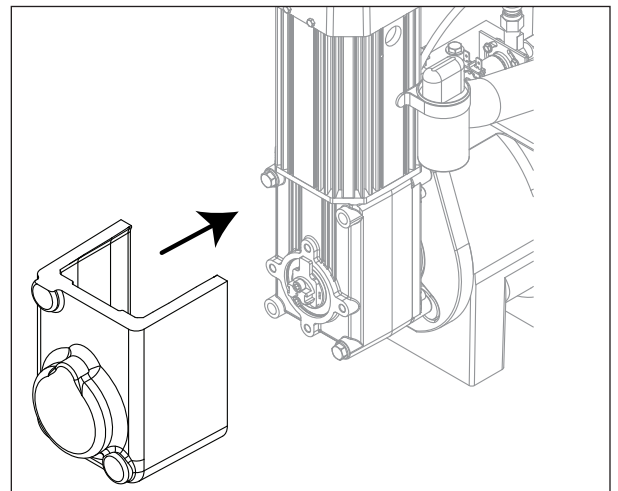

- 34. Connect transport tube to louvered docking assembly.

Fig. 32

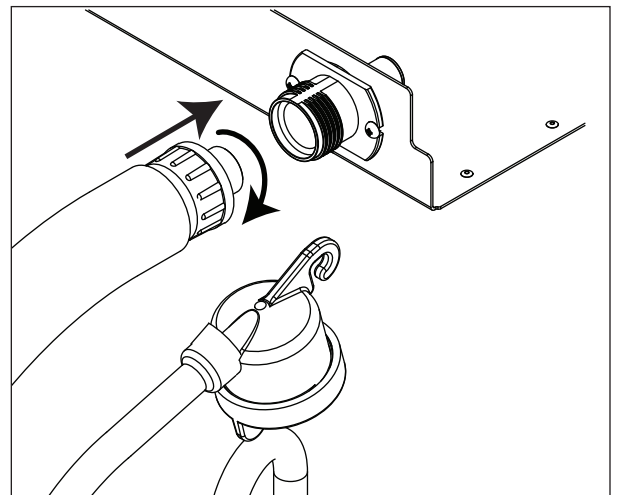

Reservoir/rear bushing disassembly Fig. 33

1. Press CLEAN button to purge evaporator. Turn power OFF when LO WATER lights.

Note: *In many applications, removing the gearmotor, main housing, and auger will allow for the ice machine to be pulled out further for better access to rear components.*

2. Slide ice machine forward to gain access.
3. Use Fig. 32 as disassembly guide.

Note: *Use petrogel when installing/reinstalling o-rings.*

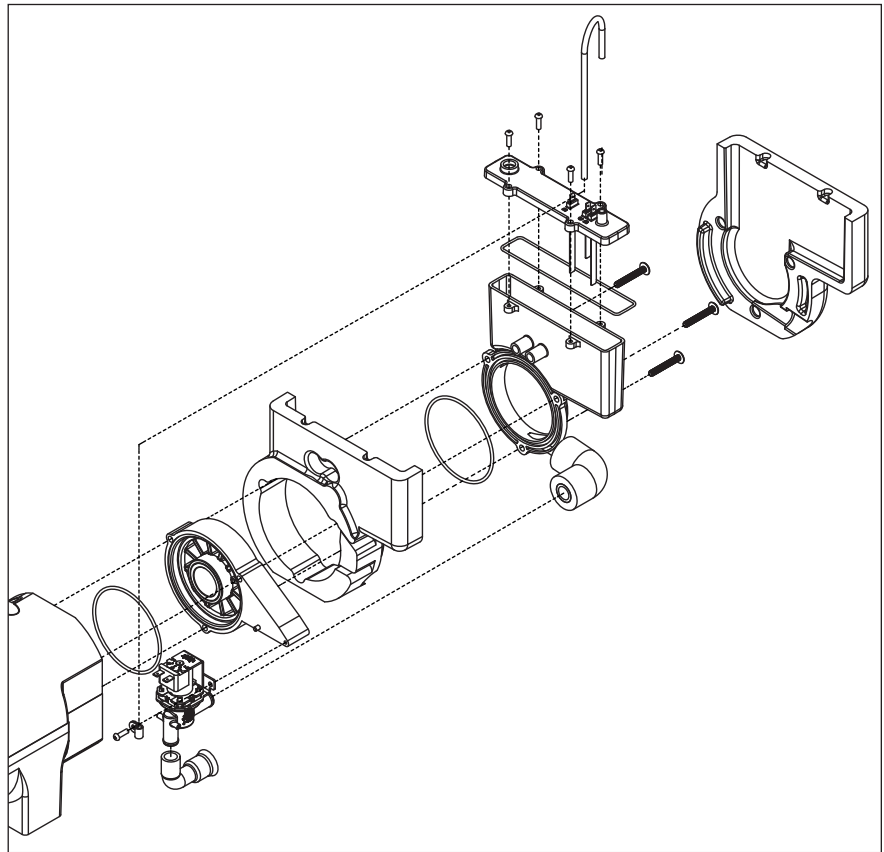

Refrigeration system

The condensing unit is weatherproof and equipped to operate in ambient temperatures from –20 F to 120 F (–29 C to 48.9 C). The condensing unit is controlled by contact closure within the ice machine control board of the 24 VAC circuit of the condensing unit. This control circuit energizes the compressor and condenser fans of the refrigeration system. After any system shutdown condensing and suction pressure are expected to slowly equalize to outdoor ambient saturation pressure.

Low ambient operation:

Reliable operation at low outdoor ambient temperature is achieved with the crankcase heater and a head pressure control valve. When the outdoor ambient falls, the condensing pressure falls. When the condensing pressure falls below the head pressure control valve set pressure (180 psig), the valve modulates to allow discharge gas to bypass the condenser. Mixing the discharge gas with receiver liquid maintains high pressure liquid at the receiver outlet. A second check valve is installed in the discharge line of the compressor to reduce refrigerant migration into the compressor during the off cycle. The system contains a crankcase heater that is thermostatically controlled (on at 60 F and off at 80 F). The heater maintains the compressor sump oil temperature above suction gas temperature to prevent liquid refrigerant from accumulating in the compressor sump.

Warm ambient operation:

During warm ambient conditions (above 180 psig saturation pressure), the discharge pressure is higher than the head pressure control valve set point therefore the head pressure control valve is not bypassing and there is full liquid flow from the condenser to the receiver.

1412 - Refrigerant pressure data (R449A)

Air-cooled condensers (air)	50 F/10 C	60 F/16 C	70 F/21 C	80 F/27 C	90 F/32 C	100 F/38 C	110 F/43 C	120 F/49 C
Pressure (psig) discharge/suction	182/18	186/19	190/20	206/21	222/22	260/24	298/26	336/28

Refrigeration system diagram

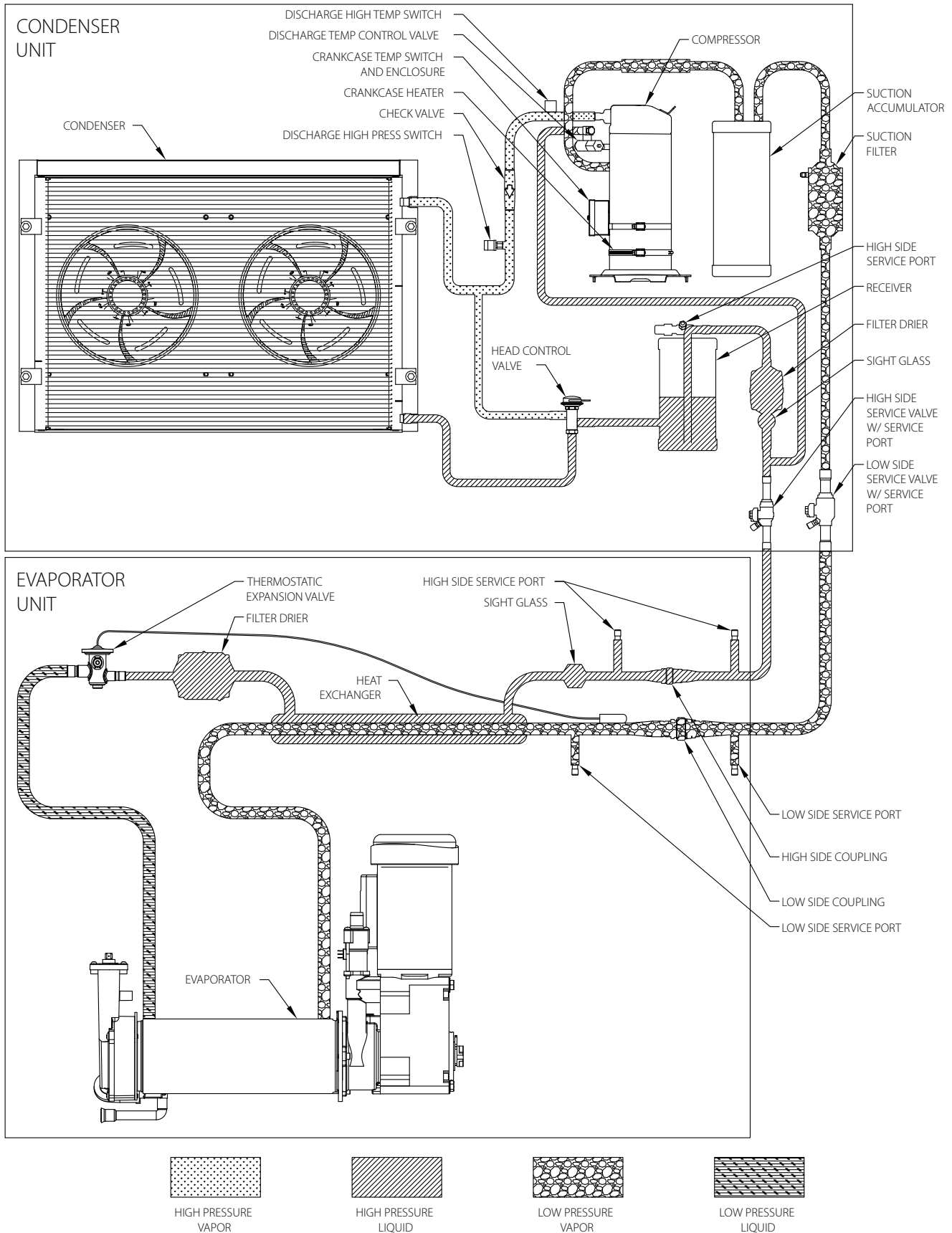

Refrigeration charge

All service on refrigeration systems must be performed in accordance with all federal, state and local laws. It is the responsibility of the technician to ensure that these requirements are met. Recharging ice machine to other than factory specifications will void the warranty.

R449A ice machine charge specifications

Model	Line Run	Total Charge
1412 three-phase	0–100 ft (0–30,5 m)	8 lb (3.63 kg)

Note: Condensing unit (F1412CU) shipped with full charge.

Refrigerant replacement requirements

1. Non-contaminated refrigerant removed from any Follett refrigeration system can be recycled and returned to the same system after completing repairs. Recycled refrigerant must be stored in a clean, approved storage container. If additional refrigerant is required, virgin or reclaimed refrigerant that meets ARI standard 700-88 must be used.
2. In the event of system contamination (for example, a compressor burn out, refrigerant leak, presence of non-condensibles or moisture), the system must be repaired, evacuated and recharged using virgin or reclaimed refrigerant that meets ARI standard 700-88.
3. Follett Products, LLC does not approve of recovered refrigerants. Improper refrigeration servicing procedures will void the factory warranty.

Evacuation

Evacuate the system to a level of 500 microns. When the 500 micron level is reached, close all valves. Allow the system to sit for approximately 20 minutes. During this period the system pressure should not rise. If the system pressure rises and stabilizes there is moisture in the system and further evacuation is needed. If the pressure continues to rise check the system for leaks.

Evaporator Unit Low-side or ice making head

Ambients	Minimum	Maximum
Air temperature	50 F/10 C	100 F/37.8 C
Water temperature ¹	45 F/7 C	90 F/32.2 C

¹Ambient water temperature is measured in the ice machine water reservoir.

Ice capacity test

Ice machine production capacity can only be determined by weighing ice produced in a specific time period.

1. Replace all panels on ice machine.
2. Disconnect the drain solenoid.
3. Run ice machine for at least 15 minutes.
4. Weigh and record weight of container used to catch ice.
5. Catch ice for 15 or 20 minutes.
6. Reconnect the drain solenoid.
7. Weigh harvested ice and record total weight.
8. Subtract weight of container from total weight.
9. Convert fractions of pounds to decimal equivalents (ex. 6 lbs 8oz = 6.5 lbs).
10. Calculate production using following formula:

$$\frac{1440 \text{ min.} \times \text{wt. of ice produced}}{\text{Total test time in minutes}} = \text{Production capacity/24 hr.}$$

11. Calculated amount per 24 hours should be checked against rated capacity for same ambient and water temperatures in Ice Production Tables.

Troubleshooting

Please see "Service" section for a description of each function.

Ice machine disposition	Possible causes	Corrective action
Legend: <input checked="" type="radio"/> ON <input type="radio"/> OFF <input type="radio"/> ON or OFF <input checked="" type="radio"/> FLASHING		
1. Machine in TIME DELAY without full bin. CLEANER FULL <input type="radio"/> DRAIN CLOG <input type="radio"/> HI PRESS <input type="radio"/> HI AMPS <input type="radio"/> SERVICE <input type="radio"/> MAINT/CLEAN <input type="radio"/> LOW WATER <input type="radio"/> TIME DELAY <input checked="" type="radio"/> NOT USED <input type="radio"/> MAKING ICE <input type="radio"/> LOW BIN <input checked="" type="radio"/> POWER ON <input checked="" type="radio"/>	1. Ice jamming due to improperly installed transport tube causing a false shuttle. 2. Shuttle stuck in up position. 3. Damaged or improperly installed thermostat (open). 4. Transport tube backed-out of coupling. 5. Damaged shuttle mechanism.	1. Correct transport tube routing. 2. Repair or replace shuttle mechanism. 3. Replace or reposition thermostat. 4. Correct coupling installation. 5. Replace or repair shuttle mechanism.
2. Ice machine is not making ice. HI AMPS. CLEANER FULL <input type="radio"/> DRAIN CLOG <input type="radio"/> HI PRESS <input type="radio"/> HI AMPS <input checked="" type="radio"/> SERVICE <input type="radio"/> MAINT/CLEAN <input type="radio"/> LOW WATER <input type="radio"/> TIME DELAY <input type="radio"/> NOT USED <input type="radio"/> MAKING ICE <input type="radio"/> LOW BIN <input checked="" type="radio"/> POWER ON <input checked="" type="radio"/>	1. Excessive scaling on internal components. 2. Damaged shuttle mechanism. 3. Intermittent drive output from PC board. Evaporator will freeze causing a HI AMPS error. 4. Gearmotor is unplugged.	1. Clean ice machine. Increase flushing frequency. Position TDS switch to High TDS setting. 2. Replace or repair shuttle mechanism. 3. Replace PC board. 4. Plug in gearmotor.
3. Ice machine is not making ice. SERVICE. CLEANER FULL <input type="radio"/> DRAIN CLOG <input type="radio"/> HI PRESS <input type="radio"/> HI AMPS <input type="radio"/> SERVICE <input checked="" type="radio"/> MAINT/CLEAN <input type="radio"/> LOW WATER <input type="radio"/> TIME DELAY <input type="radio"/> NOT USED <input type="radio"/> MAKING ICE <input type="radio"/> LOW BIN <input checked="" type="radio"/> POWER ON <input checked="" type="radio"/>	1. Internal water leak touching chassis sensor. 2. Inoperable purge solenoid.	1. Identify and repair leak. Clean/dry chassis and sensors and restart machine. 2. Test and verify purge solenoid operation.
4. Drain clog. CLEANER FULL <input type="radio"/> DRAIN CLOG <input checked="" type="radio"/> HI PRESS <input type="radio"/> HI AMPS <input type="radio"/> SERVICE <input type="radio"/> MAINT/CLEAN <input type="radio"/> LOW WATER <input type="radio"/> TIME DELAY <input type="radio"/> NOT USED <input type="radio"/> MAKING ICE <input type="radio"/> LOW BIN <input checked="" type="radio"/> POWER ON <input checked="" type="radio"/>	1. Improper flow in drain system. 2. Inoperable purge solenoid.	1. Correct/clean drain system. 2. Test and verify purge solenoid operation.

Ice machine disposition	Possible causes	Corrective action
Legend: <input checked="" type="radio"/> ON <input type="radio"/> OFF <input type="radio"/> ON or OFF <input checked="" type="radio"/> FLASHING		
5. Ice machine is making ice. Excessive water in bin or coming into bin from transport tube. CLEANER FULL <input type="radio"/> DRAIN CLOG <input type="radio"/> HI PRESS <input type="radio"/> HI AMPS <input type="radio"/> SERVICE <input type="radio"/> MAINT/CLEAN <input type="radio"/> LOW WATER <input type="radio"/> TIME DELAY <input type="radio"/> NOT USED <input type="radio"/> MAKING ICE <input checked="" type="radio"/> LOW BIN <input type="radio"/> POWER ON <input checked="" type="radio"/>	1. Failed water sensors. Processor assumes there is no water when there is water. 2. Blocked reservoir vent. 3. Defective water feed solenoid valve. Stuck in open position.	1. Clean or replace water probe assembly. Check wiring connections. 2. Clean or replace vent tubes. 3. Replace water feed solenoid valve.
6. Ice machine is not making ice. Low water. CLEANER FULL <input type="radio"/> DRAIN CLOG <input type="radio"/> HI PRESS <input type="radio"/> HI AMPS <input type="radio"/> SERVICE <input type="radio"/> MAINT/CLEAN <input type="radio"/> LOW WATER <input checked="" type="radio"/> TIME DELAY <input type="radio"/> NOT USED <input type="radio"/> MAKING ICE <input type="radio"/> LOW BIN <input checked="" type="radio"/> POWER ON <input checked="" type="radio"/>	1. Water supply is insufficient. 2. Low water pressure. 3. Defective water feed solenoid valve. Stuck in closed position. 4. No water feed output from PC board. 5. Plugged screen on inlet side of fill solenoid. 6. Plugged check valve.	1. Restore water supply and check water filters. If evaporator was completely empty the reset button may have to be pressed to restart the ice machine. 2. Ice machine will eventually start when water reaches normal lo level. 3. Replace water feed solenoid valve. 4. Replace PC board. 5. Remove and clean screen. 6. Replace check valve.
7. Blinking Low water, power, time delay. CLEANER FULL <input type="radio"/> DRAIN CLOG <input type="radio"/> HI PRESS <input type="radio"/> HI AMPS <input type="radio"/> SERVICE <input type="radio"/> MAINT/CLEAN <input type="radio"/> LOW WATER <input checked="" type="radio"/> TIME DELAY <input checked="" type="radio"/> NOT USED <input type="radio"/> MAKING ICE <input type="radio"/> LOW BIN <input type="radio"/> POWER ON <input checked="" type="radio"/>	Machine has not yet energized fill solenoid in specified amount of time during normal operation. 1. Lack of refrigeration/low refrigerant charge/leak. 2. Debris shorting reservoir probes.	1. Verify refrigerant pressures, compressor running, sight glass clear. 2. Clean probes and reservoir of debris.



ATTENTION!

To prevent circuit breaker overload, wait 5 minutes before restarting this unit. This allows the compressor to equalize and the evaporator to thaw.

Replacement parts

Evaporator assembly

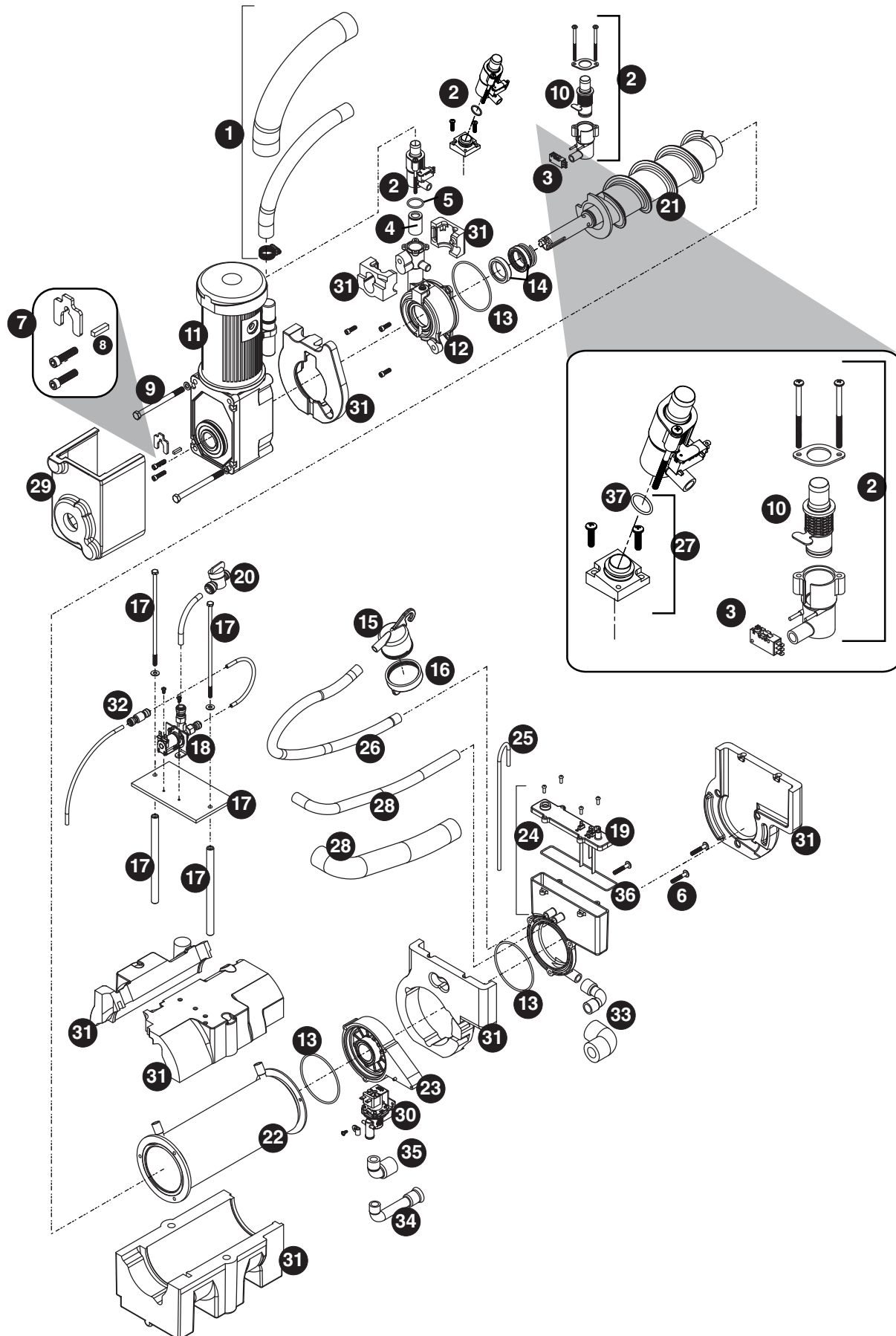

Reference #	Description	Part #
1	Tube, ice transport, insulated	01164896
2	Shuttle assembly	01118132
2	Shuttle assembly, IMDV	01118140
3	Switch, shuttle	01006261
4	Compression nozzle	01278654
5	O-ring, shuttle	01164920
6	Screw, reservoir (10 pack)	01333830
7	Auger hardware (includes screws, key, retainer)	01118611
8	Key	01164938
9	Bolt, gearmotor mounting (2) (self-contained units), includes washers	01118629
10	Cartridge assembly, shuttle spring	01118033
10	Cartridge, shuttle spring, IMDV	01118041
11	Gearmotor, 120 V (includes capacitor)	01275056
12	Main housing	01117969
13	O ring	01301720
14	Seal, auger shaft	01302249
15	Cup, sanitizer	01164995
16	Cap, sanitizer	01118637
Not shown	Tubing, water, 3/8" OD	502719
Not shown	Tubing, water, 1/4" OD	502079
17	Retainer kit, evaporator	01118652
18	Solenoid, water feed (120 V)	01223015
19	Reservoir lid and sensors (includes screws and o-ring)	01118108
20	Valve, shut-off, water	502921
21	Auger, 1412 (includes seal, key, and auger hardware)	01117936 (1412 only)
22	Evaporator, 1412	01118074 (1412 only)
23	Rear bushing housing and bushing (includes (1) o-ring)	01118082
24	Reservoir assembly, water (includes lid)	01118116
25	Tube, vent (17" required)	502079
26	Tube, sanitizer	01118660
27	Kit, MicroChewblet	01161843
28	Tube, shuttle drain, insulated	01118678
29	Insulation, gearbox	01165240
30	Solenoid, purge, 120 V	01337286
31	Insulation kit, 1412 evaporator/reservoir	01302264 (1412 only)
32	Check valve	01122381
33	Tube, drain, reservoir, insulated	01118124
35	Tube, drain, 1412	01302280 (1412 only)
36	O-ring, reservoir lid	01302298
Not shown	Kit, scale (includes reservoir, purge solenoid, drain tubes and fitting)	01122662
37	O-ring, MicroChewblet	01161850
Not shown	Drain kit (includes 2 ft. x 1" OD silicone tubing, 3/4" x 1" slip, 3/4" barb 3/4" FPT (2), 3/4" barb x 3/4" FPT elbow)	01210350

Low-side assembly

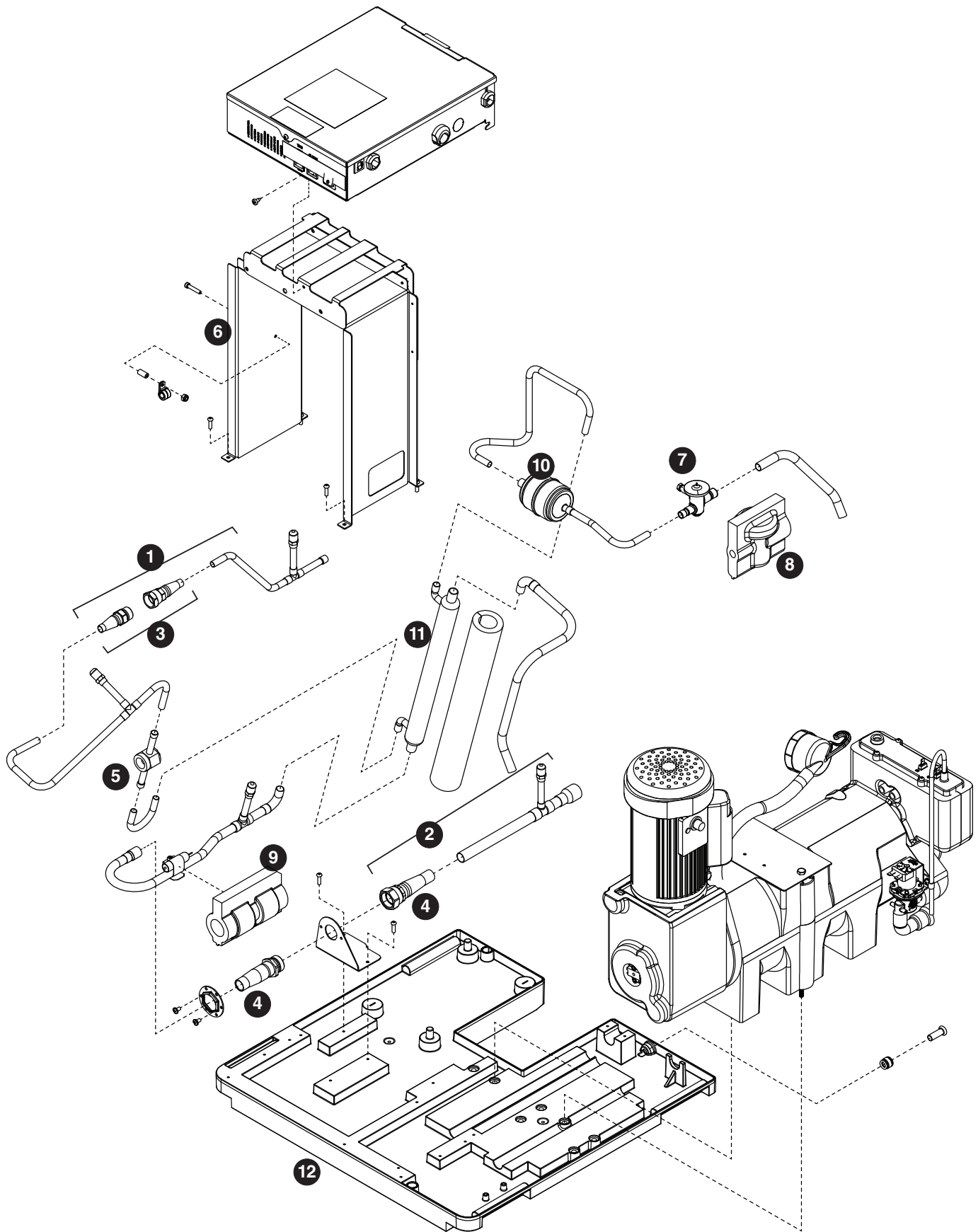

Reference #	Description	Part #
1	Tubing, liquid line, quick connect	01165554
2	Tubing, suction line, quick connect	01165562
3	Coupling set, liquid line, quick connect, 3/8"	01363910
4	Coupling set, suction line, quick connect, 5/8"	01363928
5	Sight glass	01165570
6	Electrical box support	01121292
7	TXV with filter drier R449	01536697
8	Insulation, TXV body	208881
9	Insulation, TXV bulb	00106534
10	Filter drier	01153683
11	Heat exchanger (includes insulation)	01121409
12	Base, split system	01333772

Electrical box

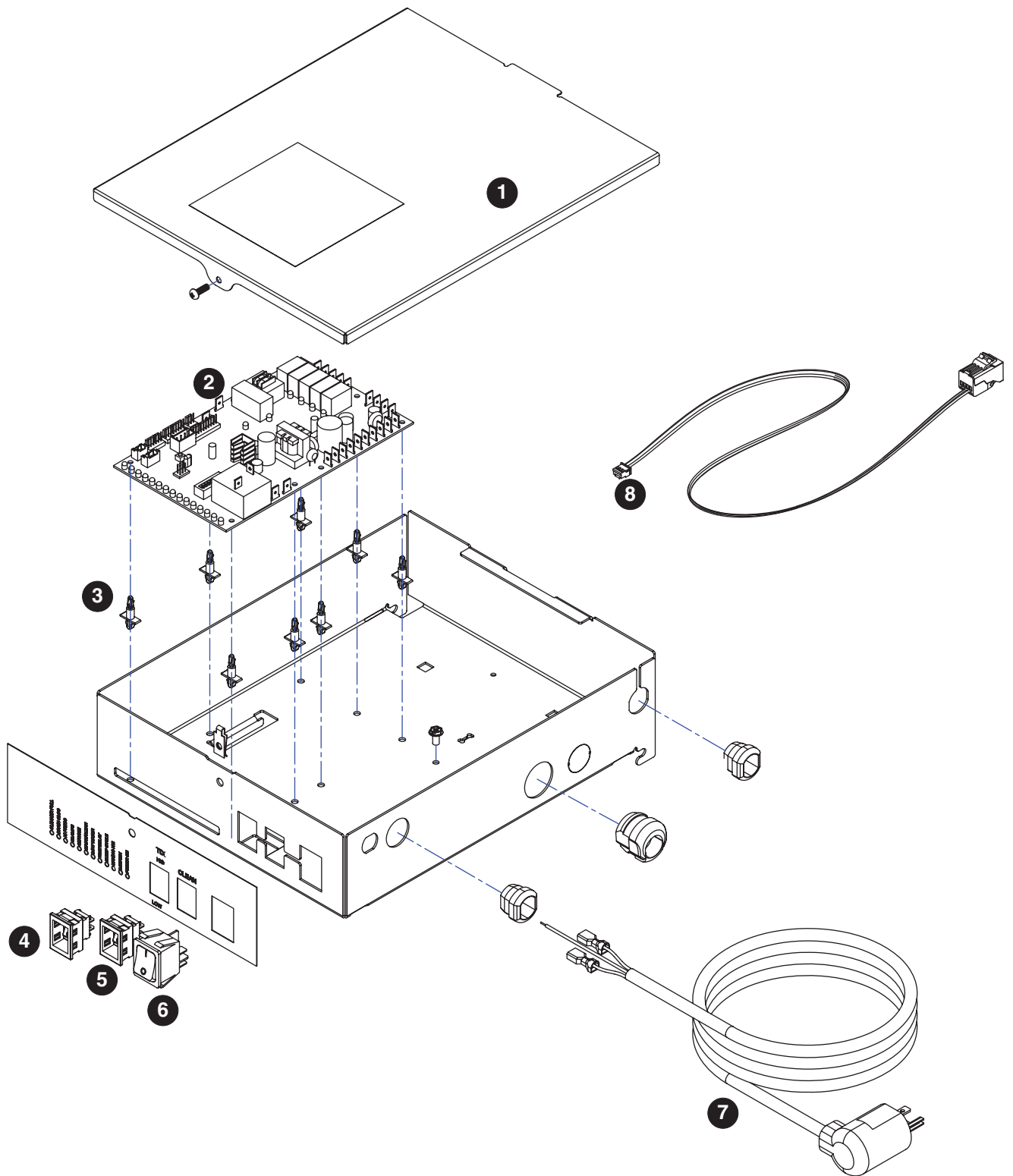

Reference #	Description	Part #
1	Cover, electrical box, air/water-cooled	01118975
2	Board, control, 120 V (includes stand-offs)	01117829
3	Stand-offs (set of 8)	00130906
4	Switch, TDS	01165695
5	Switch, evaporator clean	01165703
6	Switch, ice machine power	01165711
7	Cord, power, 120 V	01111491
8	Cable, IMDV	01302983
Not shown	24 VAC Internal Signal Wire	01453745

Integration kit – top-mount and RIDE remote ice delivery

Top mount configuration

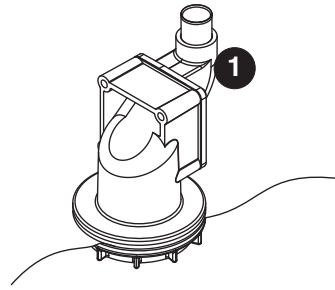
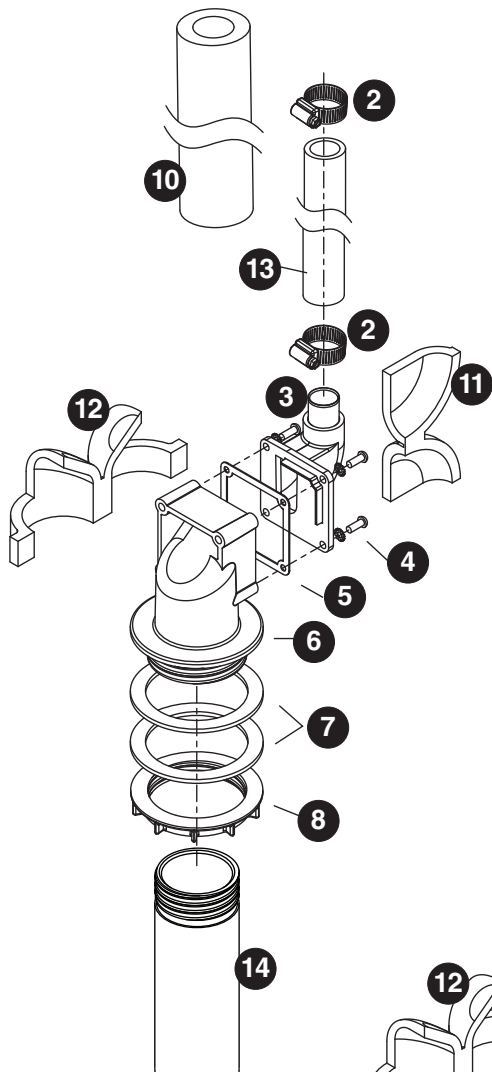

RIDE model configuration

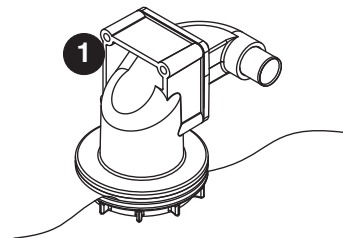
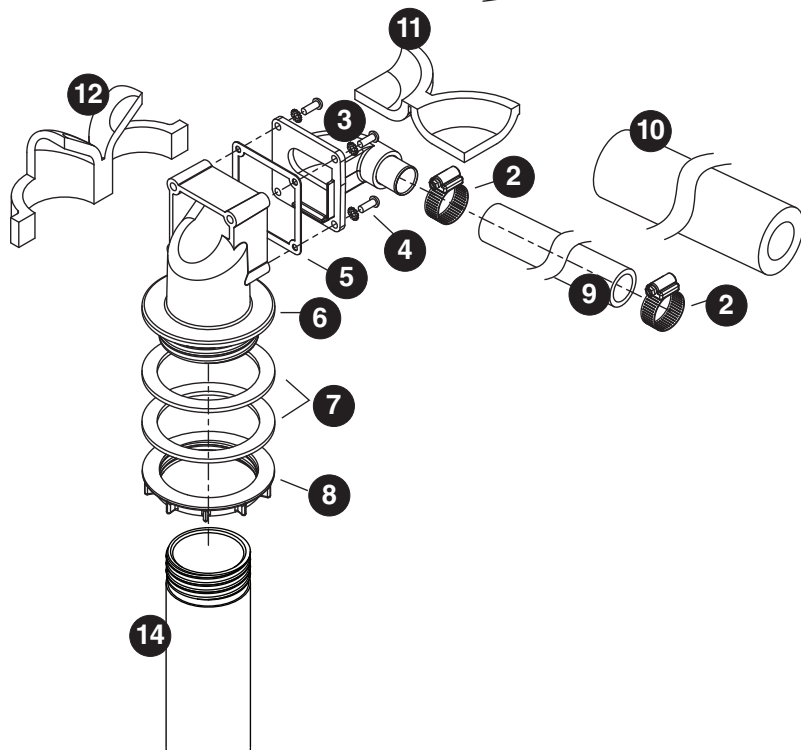

Reference #	Description	Part #
1	Shuttle actuator	00171322
2	Clamp	500377
3	Actuator elbow (includes 00167122 and 209100)	00171264
4	Screws	01303064
5	Gasket	01303072
6	Actuator body	00171272
7	Gasket, coupling	01303080
8	Ring, locking (includes 00126532)	00171371
9	Ice transport tube, 10' (3 m)	00171280
9	Ice transport tube, 20' (6 m)	00171298
10	Insulation, transport tube	501176
Not shown	Insulated polywire ice transport tube, per foot	00174896
11	Insulation, elbow	01303098
12	Insulation, actuator	01303106
13	Ice transport tube, top mount, 30" (762 mm)	00171306
14	Extension-fill tube, 9"	01303114
14	Extension-fill tube, 4"	01303122
Not shown	Integration kit, top mount, Harmony or Bin	00171389
Not shown	Integration kit, RIDE model, Harmony or Bin, (includes 10' (3 m) of tube and insulation)	00171397
Not shown	Integration kit, drop in	00145334
Not shown	Integration kit, Cornelius PR150	00144774
Not shown	Integration kit, Vision (does not include ice tube)	00997171
Not shown	Diverter plate (single agitator Cornelius dispensers and left-hand dispense chute on dual-agitator Cornelius dispensers)	01303130
Not shown	Diverter plate (right-hand dispense chute on dual-agitator dispensers)	00996207
Not shown	SafeCLEAN Plus, case of 6	01149954
Not shown	SafeCLEAN Plus, case of 24	01149962
Not shown	SafeCLEAN Plus, case of 4 one gallon bottles	01555077
Not shown	Sani-Sponge kit	00132068
Not shown	High-capacity filter system	01303148
Not shown	Primary filter (1)	01333814
Not shown	Primary filter (6)	00978973
Not shown	Pre-filter (1)	01333822
Not shown	Pre-filter (12)	00954305
Not shown	IMSII or IMSIII sanitizer concentrate - 16 oz.	00979674
Not shown	Sponge, sanitary, pack of 24	01075431
Not shown	Cable, Comm, IMDV-2CM board interface	01551365
Not shown	Kit, Legacy IMDV Dual spring (included IMDV cartridge and communication cable)	01116177
Not shown	Tubing, silicone (per foot)	01303155

Skins assembly

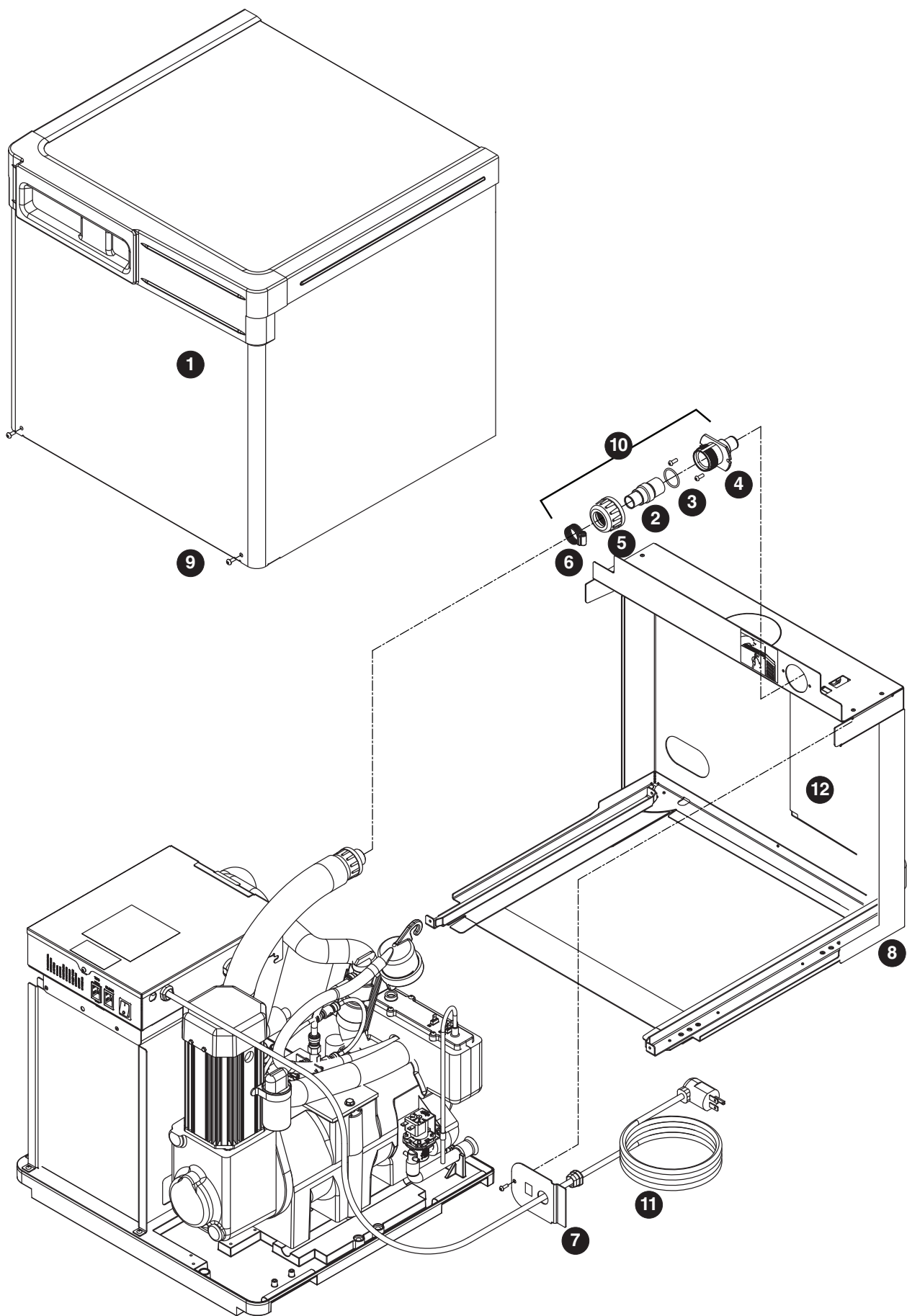

Reference #	Description	Part #
1	Cover, front	01363936
2	Coupling (includes O-ring)	00171207
3	O-ring	01303171
4	Bulkhead fitting	00171215
5	Cap, nut, ice hose	01303189
6	Hose clamp	500377
7	Plate, strain relief	00192070
8	Docking assembly (includes strain relief plate, bulkhead fitting)	01383389
9	Screw	01303197
10	Bulkhead connector kit	00171223
11	Cord and plug, power	01111491
Not shown	Fitting, drain	00109728
12	Rear cover, 1412	01383371 (1412 only)

1412 3-phase condensing unit – F1412CU

Top View

Side View

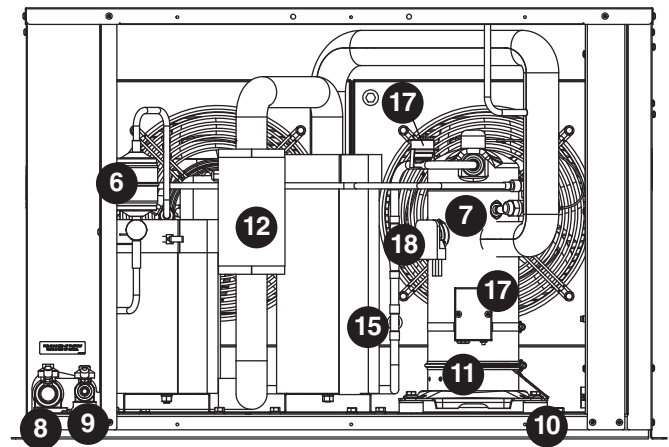
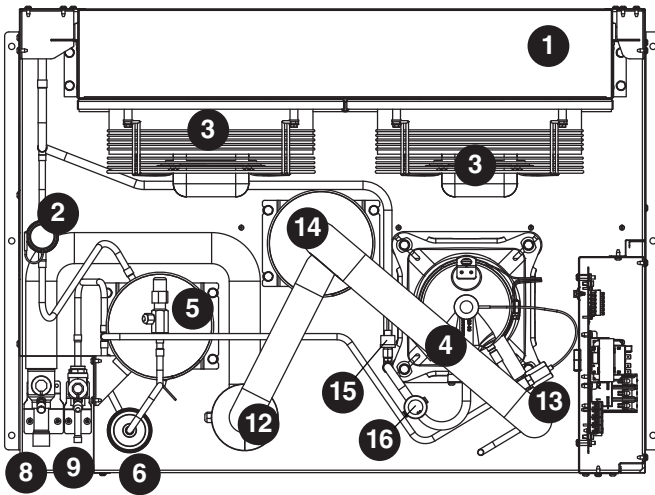



Reference #	Description	Part #
1	Condenser, with fan	01450295
2	Head Pressure Control Valve	01450519
3	Condenser Fan Motor	01450311
4	Vibration Absorber	01450451
5	Receiver Kit	01450303
6	Filter Drier, Liquid	01450493
7	Compressor Kit	01450386
8	Service Valve 7/8", Suction	01450485
9	Service Valve 3/8", Liquid	01450501
10	Compressor Mounting Kit	01536663
11	Compressor Crankcase Heater	01450444
12	Filter, Suction	01450477
13	Valve, Discharge Temperature Control	01450394
Not shown	Contactora, 3-pole	01450352
Not shown	Phase Monitor	01450337
14	Suction Accumulator	01450402
15	High Pressure Control Switch	01450469
16	Discharge Thermostat	01450436
17	Crankcase Heater Thermostat	01450428
18	Plug, Power, Compressor	01450410
Not shown	Rear Grill	01536671
Not shown	Guard, Hail & Rain	01453653
Not shown	KIT, SIGNAL 24 VAC	01453745

Note: Overload is internal to compressor.

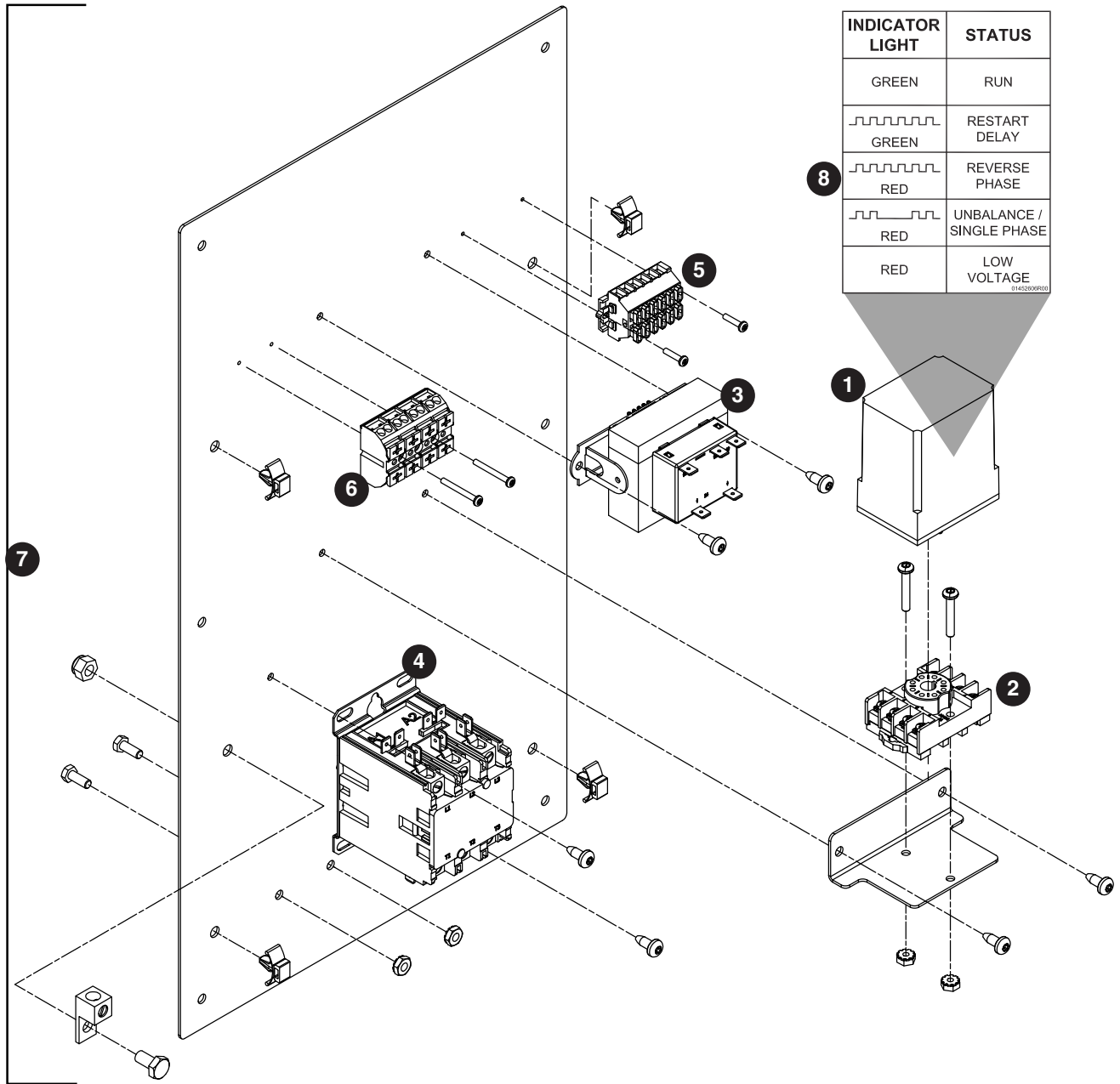
1412 3-phase condensing unit



INDICATOR LIGHT	STATUS
GREEN	RUN
 GREEN	RESTART DELAY
 RED	REVERSE PHASE
 RED	UNBALANCE / SINGLE PHASE
RED	LOW VOLTAGE

Reference #	Description	Part #
1	Phase Monitor and Label	01450337
2	Phase Monitor Base	01453752
3	Transformer 208/24 VAC	01450345
4	Contactor, 3-pole	01450352
5	Terminal 4 pole	01450360
6	Terminal 6 pole	01450378
7	Electrical panel, 3PH	01450329
8	Phase Monitor Label	01457613
Not shown	Hardware kit	01516392

Note: Overload is internal to compressor.

Horizon, Horzone Elite, Harmony, Ice Manager, SafeCLEAN, Sani-Sponge and Vision are trademarks of Follett Products LLC.
Chewblet, RIDE and Follett are registered trademarks of Follett Products LLC, registered in the US.



801 Church Lane • Easton, PA 18040, USA
Toll free (877) 612-5086 • +1 (610) 252-7301
www.follettice.com

01519206R04
© Follett Products, LLC 5/25