

Horizon Elite™ Ice Machine Models with RIDE™ Technology Installation Instructions for Drop-In

D710, E710, C1010, C1410

Order parts online
www.follettice.com

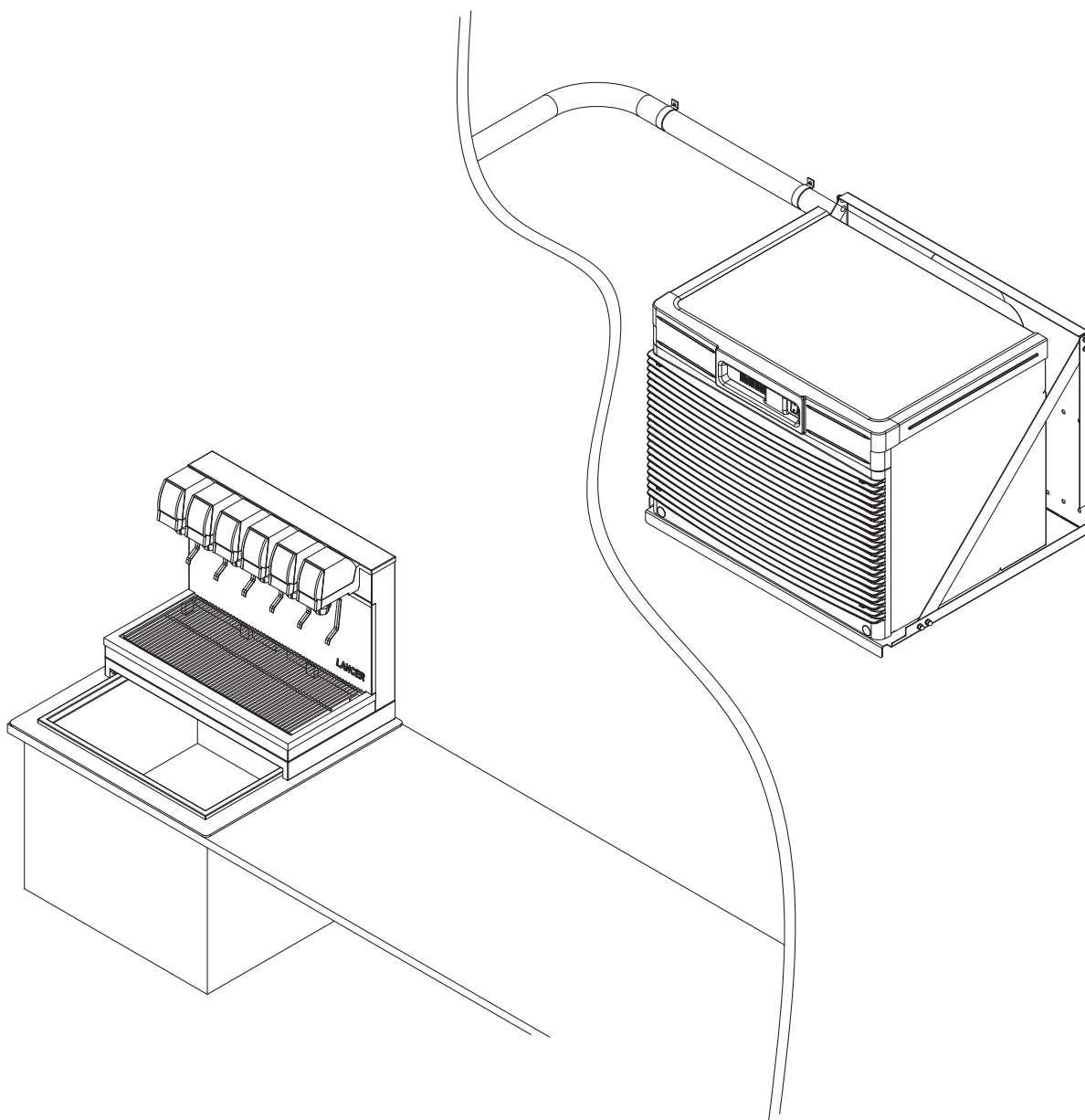
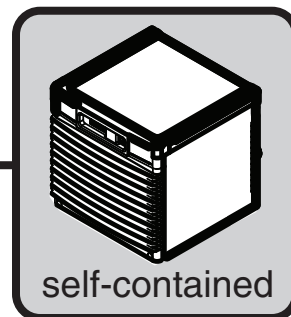

801 Church Lane • Easton, PA 18040, USA
Toll free (877) 612-5086 • +1 (610) 252-7301
www.follettice.com

01113281R06

 **CAUTION!**

- This appliance should be connected by a qualified person in accordance with applicable codes.
- If the supply cord is damaged, it must be replaced by the manufacturer, its service agent or similarly qualified persons in order to avoid a hazard.
- Connect to potable water supply only.
- This appliance can be used by children aged 8 years and above and persons with reduced physical, sensory, or mental capabilities, or lack of experience and knowledge if they have been given supervision or instruction concerning use of the appliance in a safe way and understand the hazards involved. Children should be supervised to ensure that they do not play with the appliance.
- This appliance is intended to be used for household and similar applications such as staff kitchen areas in shops, offices and other working environments; farm houses and by clients in hotels, motels and other residential type environments; bed and breakfast type environments; catering and similar non-retail applications.
- **WARNING!** To avoid a hazard due to instability of the appliance, it must be fixed in accordance with the instructions.

Read and complete the following 8 installation steps

1 **Unpack** _____



2 **Site preparation** _____



3 **Dispenser preparation** _____



4 **Docking assembly** _____

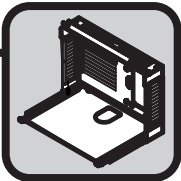

5 **Ice transport tube** _____



6 **External connection** _____



7 **Internal connection** _____



8 **Front cover** _____

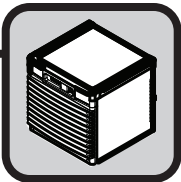

Carefully unpack and inspect the contents of your Follett ice machine.

Unpack

1



1.1 Unpack ice machine

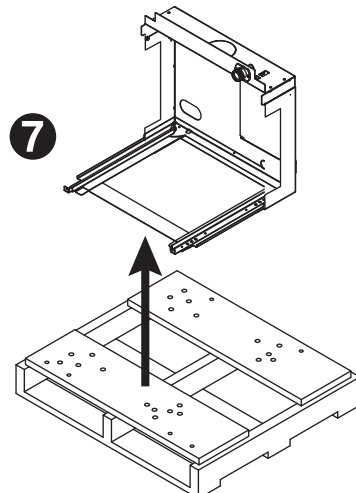
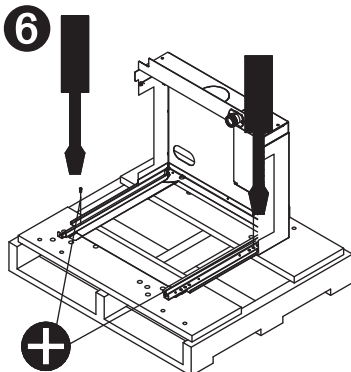
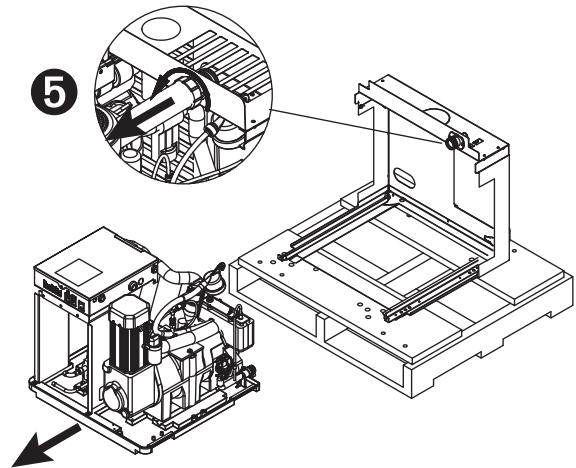
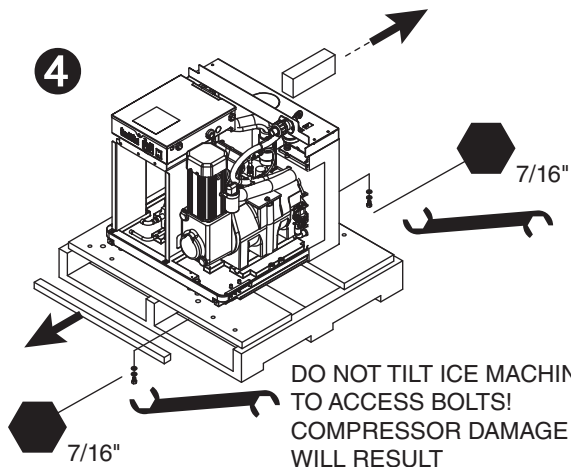
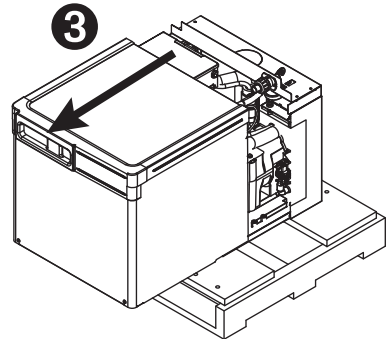
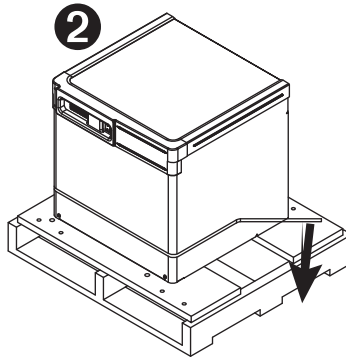
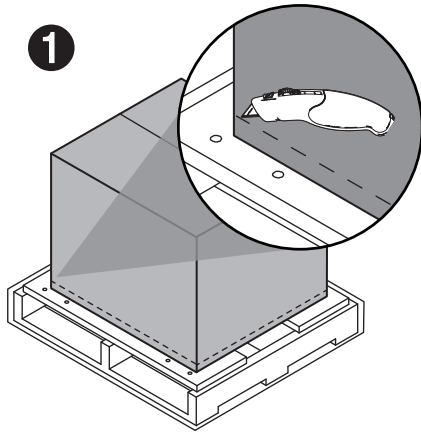

Prepare the installation site.

Provide drainage, water supply and electrical power to within 6 feet (2m) of ice machine in accordance with local and national codes. Outdoor installation is not recommended and will void warranty.

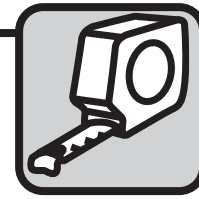

2.1 Installation site requirements

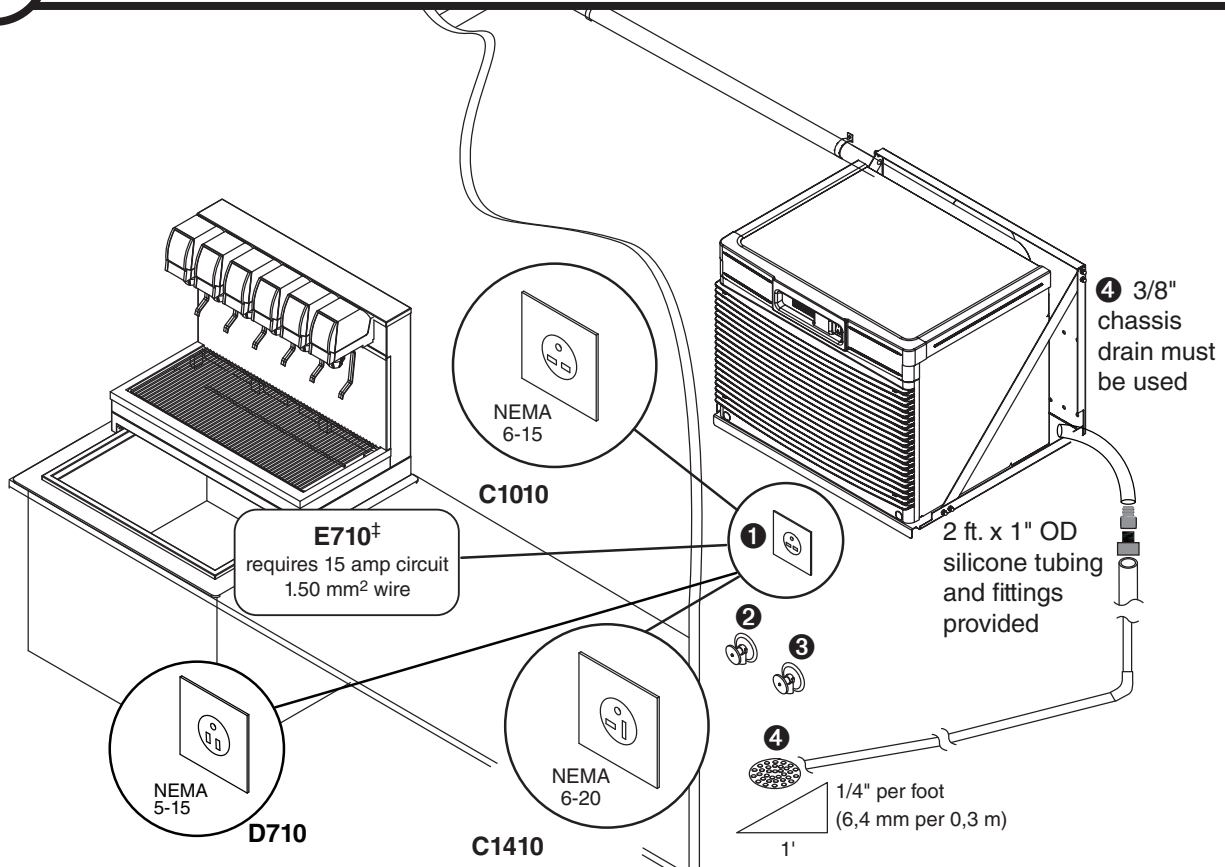

Electrical **1**

- C1010/C1410 208-230/60
 - C1410 208-230/60
 - D710 115/60 (Requires dedicated 15A circuit)
 - E710 230/50[‡]
- [‡] E710 requires 15A dedicated circuit 1.50 mm² wire. Plug must be provided by end user and must conform to standard EN 60 335-2-24 of the end destination.

Potable water supply **2** (3/8" push-in connection, 3/8" OD tubing required)

- 10-70 psi (69-483 kpa)
- 45 to 90 F (7 to 32 C)
- Follett recommends the use of an in-line water filtration system (item# 00130286)
- This equipment is to be installed with adequate backflow protection to comply with applicable federal, state, and local codes

Condenser water supply for water-cooled systems **3** (1/4" FPT inlet, 1/4" FPT outlet)

- 10 psi min.; 150 psi max. (69 kpa min.; 1034 kpa max.)
- 45 to 90 F (7 to 32 C)
- 1.5 gallons per minute (5.68 liters per minute)

Drains: **3** 3/4" Barb for silicone drain, 3/8" push-to-connect for chassis drain

- Minimum 8" radius on silicone drain line. Drain line from the ice machine must have at least 1/4" per foot pitch (6,4mm/0,3m).

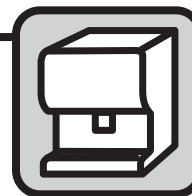

3.1 Dispenser preparation

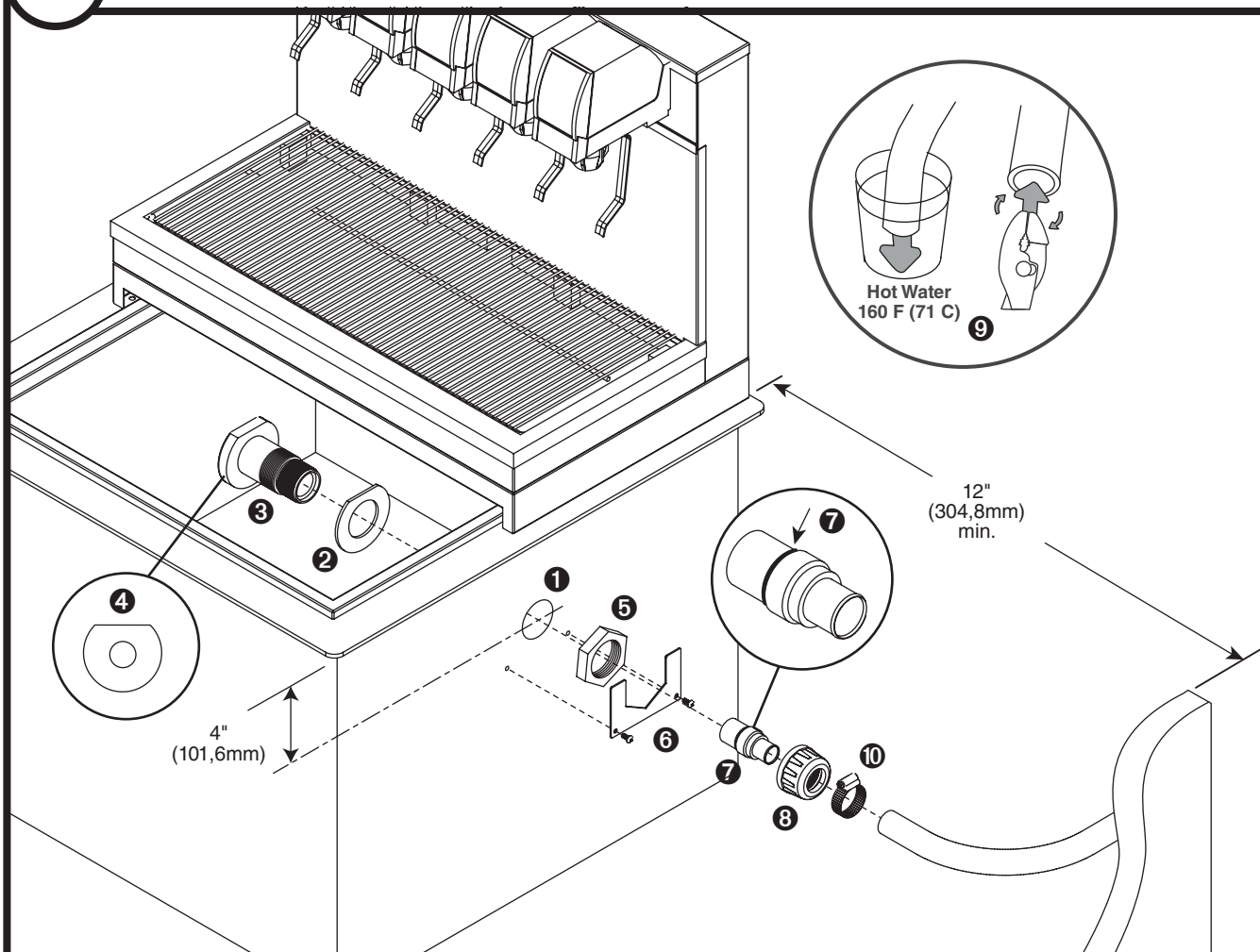

- Determine best route for ice transport tube run. **Note:** 12" (304,8 mm) clearance is required.
- Drill 1 3/4" (44,5 mm) hole through either side of dispenser ①
- Install gasket ② onto bulkhead fitting ③
- Attach bulkhead fitting with flat up ④ and tighten bulkhead nut ⑤
- Position and secure nut locking plate ⑥ with supplied screws
- Verify installation of O-ring on stainless steel ice transport tube coupling ⑦
- Insert stainless steel ice transport tube coupling ⑦ into bulkhead fitting and secure with coupling cap ⑧
- Heat end of transport tube in cup of 160 F (71 C) hot water to soften and spread with pliers ⑨ before making connection to ease assembly
- Attach ice transport tube to coupling with supplied hose clamp ⑩

Install the docking assembly.



BEFORE PROCEEDING

Prior to installing the docking assembly, ensure that the drain fitting is oriented (right or left) correctly for your installation. An optional straight drain fitting is also supplied. You may need to remove the back panel of the docking assembly in order to re-orient or change the drain fitting. Replace back panel prior to mounting the docking assembly.

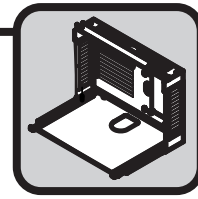

Wall bracket accessory

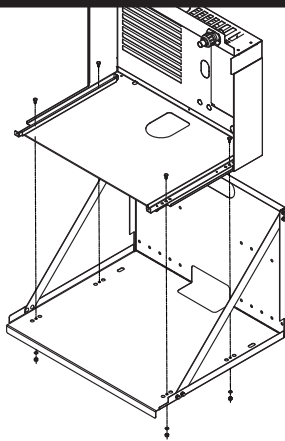

- Mount docking assembly to wall bracket accessory

Machine stand accessory

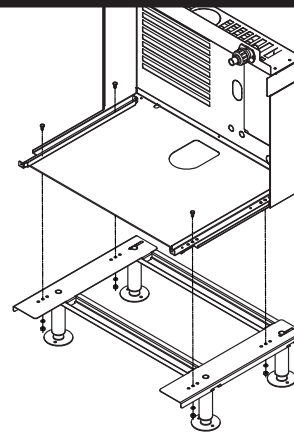

- Mount docking assembly to machine stand accessory

4.1 Undercounter installation requirements

DOCKING STATION

- Position and screw docking assembly to the bottom of counter inside of access panel/door ❶
1010/1410: 2.25" (57 mm) from the front edge of assembly
710: 3.25" (82.55 mm) from the front edge of the cross brace
- The mounting surface for the docking assembly must be solid. Do not mount directly onto runners or channels.
- There must be no lip or edge that would hinder the ice machine from sliding in or out of the docking station ❷

INTAKE AND EXHAUST GRILLE PLACEMENT: Air-cooled models only

- Position the intake grille cutout in the access panel/door
Note: Ice machine must be aligned with cutout and inside of access panel to provide a tight seal and prevent recirculation of hot exhaust air.
- Left edge of cutout from the left side of the ice machine ❸
1010/1410: 2.25" (57 mm)
710: 2" (51 mm)
- Bottom edge of cutout should be 2" (51 mm) from the bottom of the ice machine ❹
- Position supplied exhaust grille at least 18" (458mm) away from intake grille ❺.
Where possible, install exhaust grille to the rear or side of the base cabinet.
- If not using supplied grille, air circulation requirements below must be met:
1010/1410: 250 sq. in (1613 sq cm) intake/exhaust air
710: 160 sq. in (1032 sq cm) intake/exhaust air

Undercounter installation detail

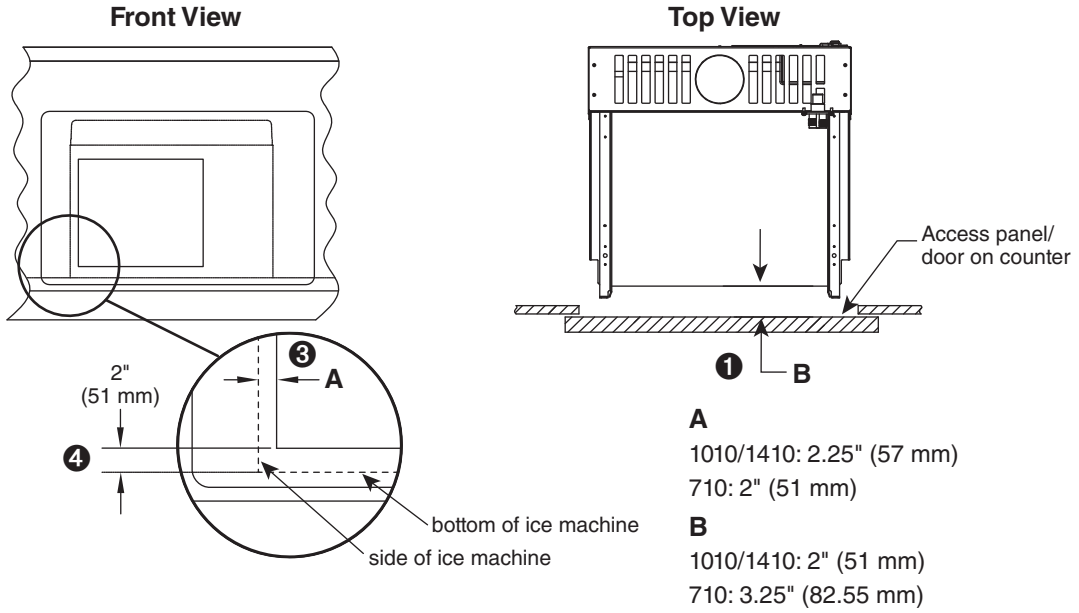

⚠ CAUTION

- Keep ventilation openings in the appliance enclosure clear of obstruction. Failure to do so could result in damage to equipment.
- To ensure proper ventilation (if not using supplied grille) carefully review air circulation specifications on previous page (4.1)

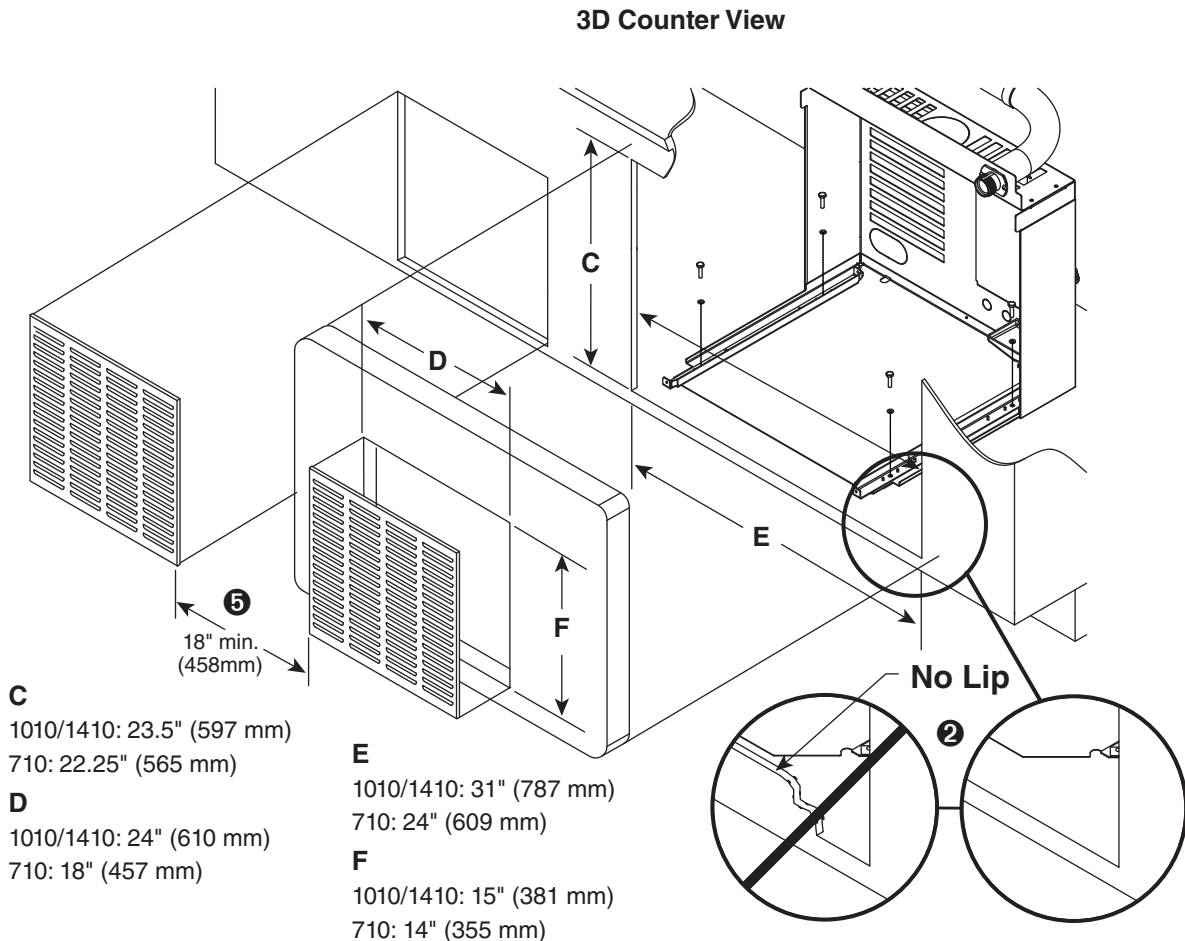

Install the ice transport tube.



5.1 Ice transport tube installation.

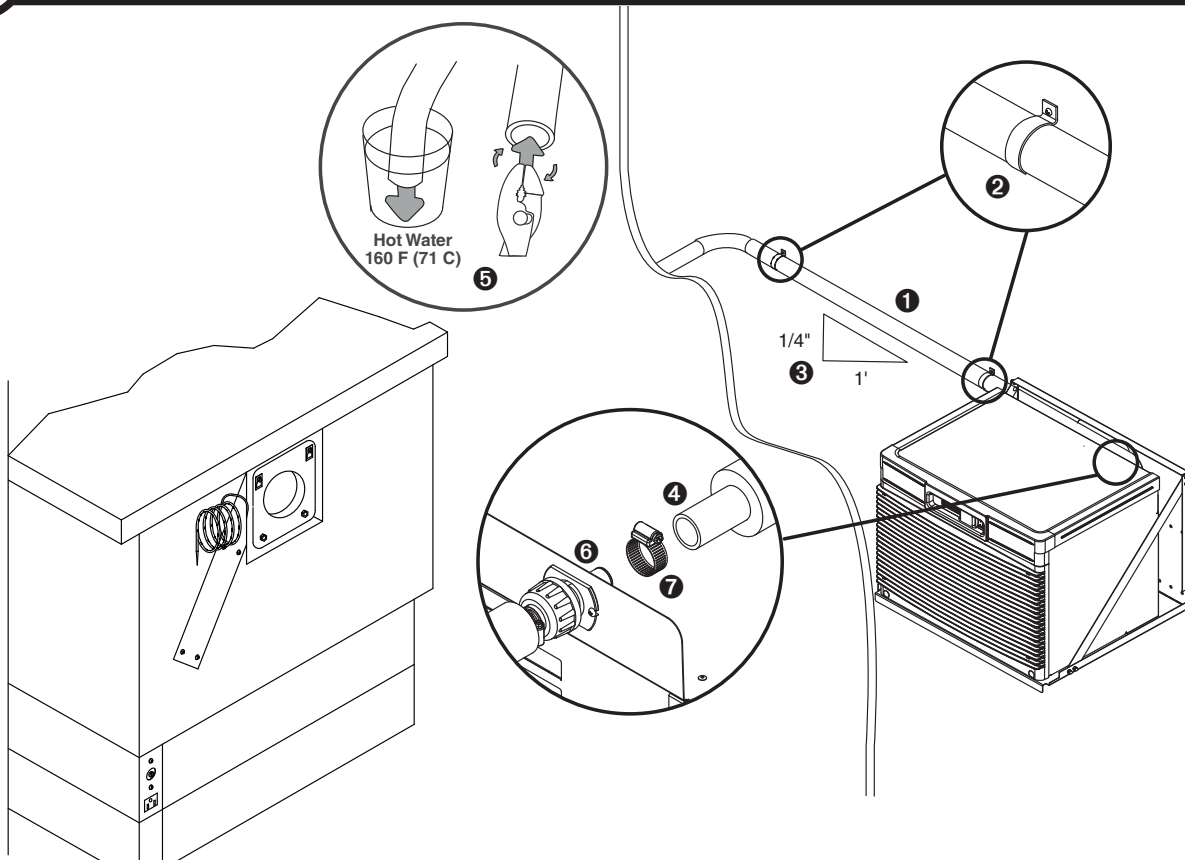

Ice transport tube tips

- Insulate entire length of ice transport tube ①
- Secure ice transport tube ② as needed to prevent dips and traps from forming. For long tube runs see guide on page 15.
- Pitch tube at least 1/4" per foot (6,4mm/0,3m) ③
- Ice transport tube must drain towards ice machine

Ice transport tube to Ice machine

- Be sure tube ends are square ④
- Heat end of transport tube in cup of 160 F (71 C) hot water to soften and spread with pliers ⑤ before making connection to ease assembly
- Push ice transport tube onto ice machine nipple ⑥
- Install hose clamp ⑦

Connect utilities to docking assembly.

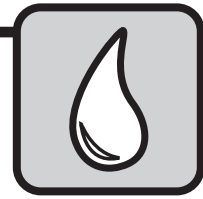

6.1 Air-cooled ice machines only

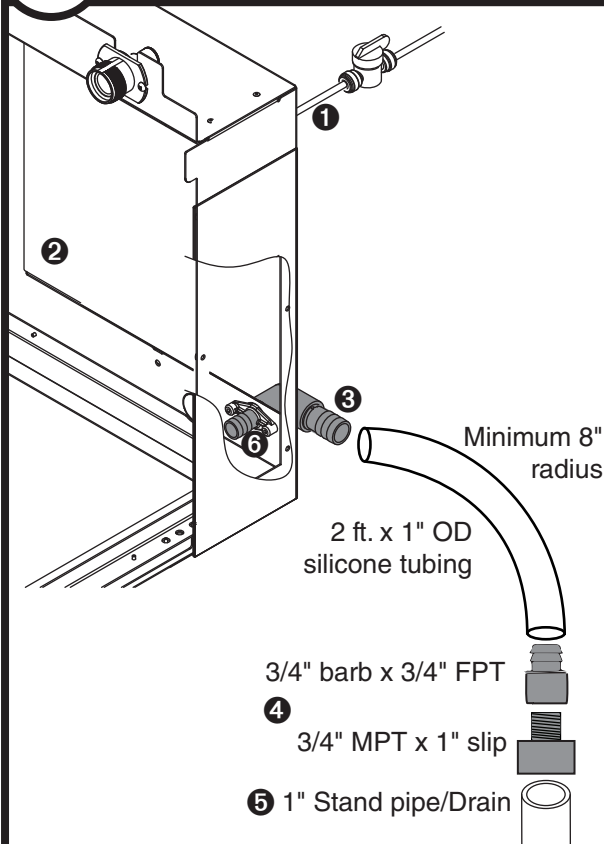

- Rough-in ice machine potable water supply ①. 3/8" push-in connection will be made at included shut-off valve then at back of docking station into solenoid.
 - Remove access panel if necessary ②.
 - Connect the silicone tubing to the ice machine 3/4" drain barb ③.
 - Assemble the 3/4" barb x 3/4" FPT to the 3/4" MPT x 1" slip. Connect the other end of the silicone tubing to the 3/4" barb ④.
 - Connect the 1" slip fitting to the 1" stand pipe/drain ⑤.
- Note:** Minimum 8" radius on silicone drain line. Drain line from the ice machine must have at least 1/4" per foot pitch (6,4 mm/0,3 m).
- Apply Petrol-gel to barbed drain fitting ⑥
 - Replace access panel.

6.2 Water-cooled ice machines only

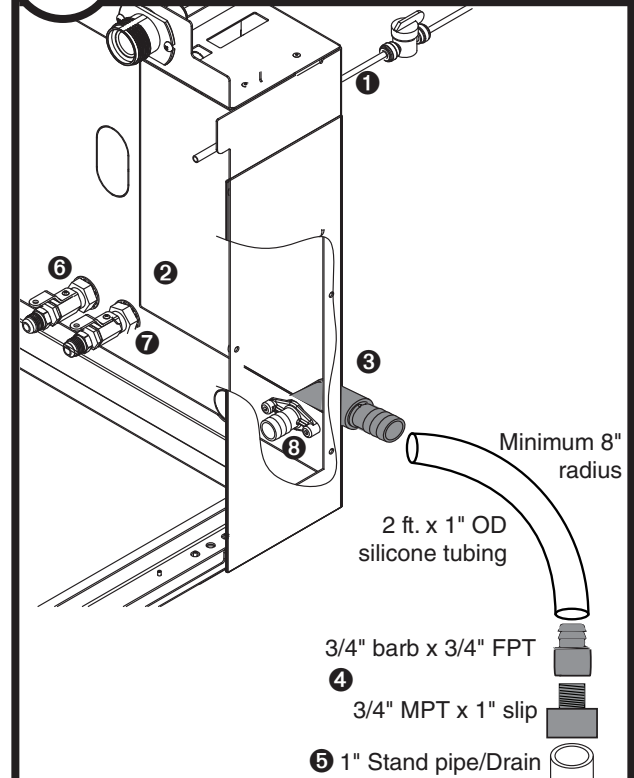

- Rough-in ice machine potable water supply ①. 3/8" push-in connection will be made at included shut-off valve then at back of docking station into solenoid.
 - Remove access panel if necessary ②.
 - Connect the silicone tubing to the ice machine 3/4" drain barb ③.
 - Assemble the 3/4" barb x 3/4" FPT to the 3/4" MPT x 1" slip. Connect the other end of the silicone tubing to the 3/4" barb ④.
 - Connect the 1" slip fitting to the 1" stand pipe/drain ⑤.
- Note:** Minimum 8" radius on silicone drain line. Drain line from the ice machine must have at least 1/4" per foot pitch (6,4 mm/0,3 m).
- Connect cooling water supply ⑥ and return ⑦
 - Apply Petrol-gel to barbed drain fitting ③
 - Replace access panel.

Chassis drain plumbing - required

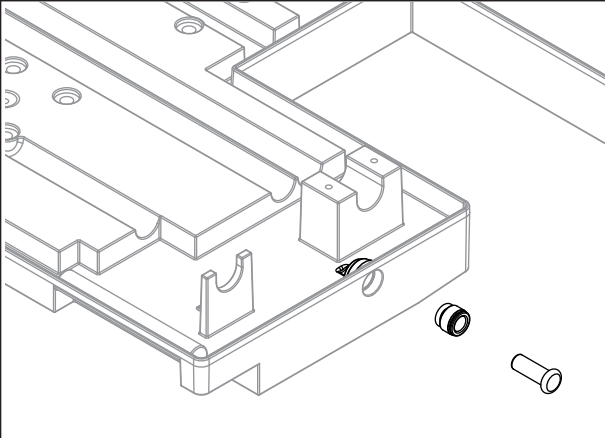

- Plug must be removed from John Guest fitting.
- Route 3/8" drain tubing through knockout in back of docking station and insert fully into John Guest fitting connection at the rear of the machine chassis. Route other end of 3/8" drain tubing to drain.
- Drain must slope 1/4" inch per foot (6 mm per 30,4 cm).

Connect docking assembly to ice machine.

CAUTION

- Plug must be accessible after final installation.
- E710 230/50/1) requires a 15 amp circuit (1.50 mm² wire)

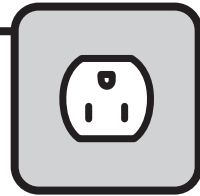

Air-cooled ice machines – follow steps 7.1 through 7.5.

7.1 Ice transport tube

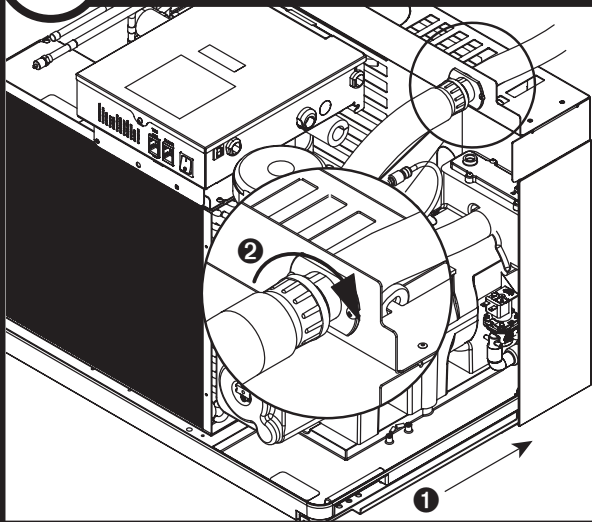

- Slide ice machine into docking assembly *ensuring that drain tube is fully seated on barbed drain fitting* ①
- Insert ice transport tube all the way into coupling and tighten nut firmly ②

7.2 Water solenoid, shut-off valve, and potable water line options

If water solenoid is already mounted to evaporator:

- Insert potable water line into shut-off valve.

If this is an undercounter installation:

- Mount water solenoid atop evaporator and locate the shut-off valve *inside* the machine. Insert potable water line into shut-off valve.

If water solenoid is not mounted and machine will not be installed under-counter:

- Mount water solenoid to inside rear (upper right corner) of docking assembly using one screw.
- Insert potable water line into shut-off valve - locate the shut-off valve *outside* the machine.
- Insert outgoing line from shut-off valve into push-in connection of water solenoid.

7.3 Power cord

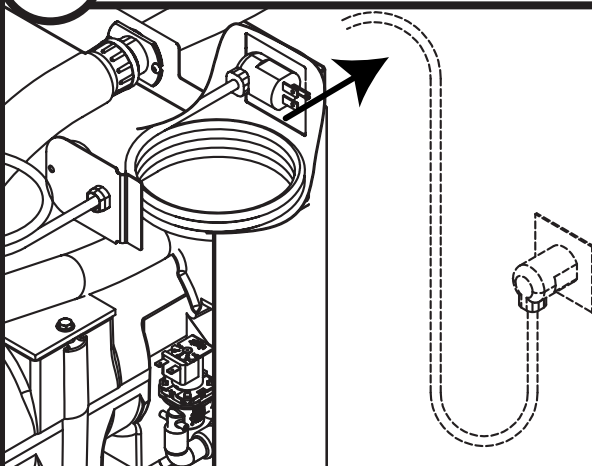

- Remove twist tie
- Carefully pass cord thru opening and plug into wall outlet

7.4 Power cord

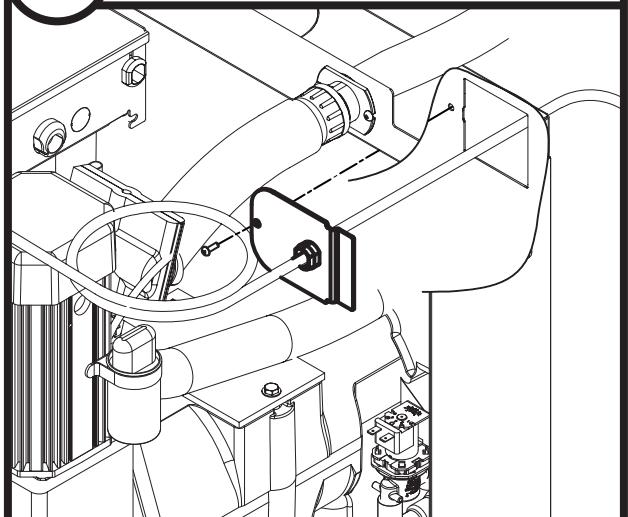

- Position plate into opening and secure with supplied screw

Water-cooled ice machines – follow steps 7.6 through 7.12.

7.5 TDS switch

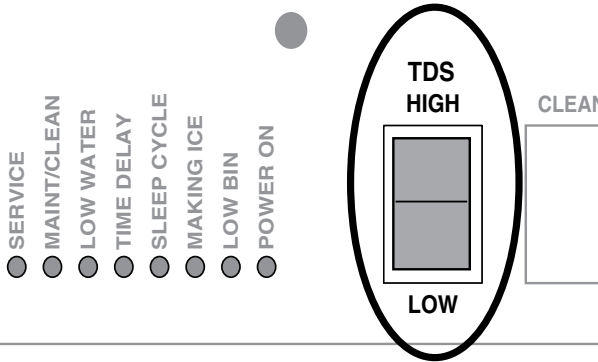

- Set the TDS switch on the electrical box:
HIGH: for extended service life
LOW: for low-scale water

7.6 Cooling lines

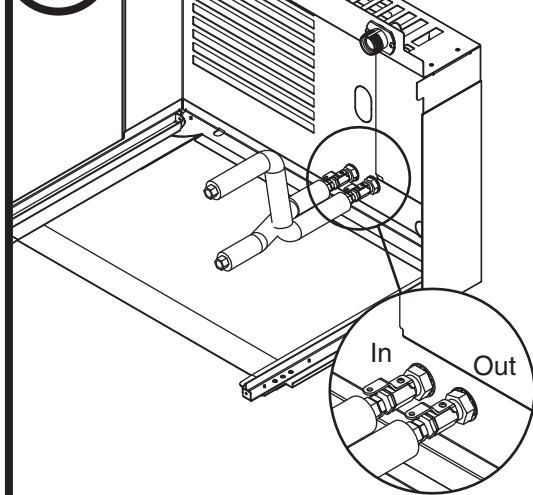

- Install ice machine cooling water lines to docking assembly

7.7 Ice transport tube

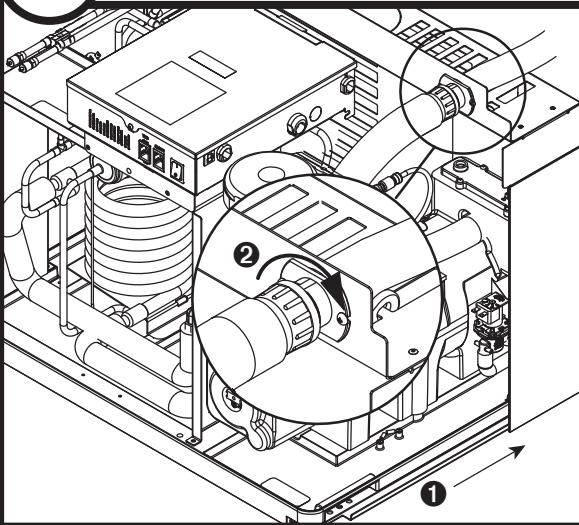

- Slide ice machine into docking assembly ensuring that drain tube is fully seated on barbed drain fitting **1**
- Insert ice transport tube into coupling and tighten nut firmly **2**

7.8 Water solenoid, shut-off valve, and potable water line options

If water solenoid is already mounted to evaporator:

- Insert potable water line into shut-off valve.

If this is an undercounter installation:

- Mount water solenoid atop evaporator and locate the shut-off valve *inside* the machine. Insert potable water line into shut-off valve.

If water solenoid is not mounted and machine will not be installed under-counter:

- Mount water solenoid to inside rear (upper right corner) of docking assembly using one screw.
- Insert potable water line into shut-off valve - locate the shut-off valve *outside* the machine.
- Insert outgoing line from shut-off valve into push-in connection of water solenoid.

7.9 Cooling lines and power

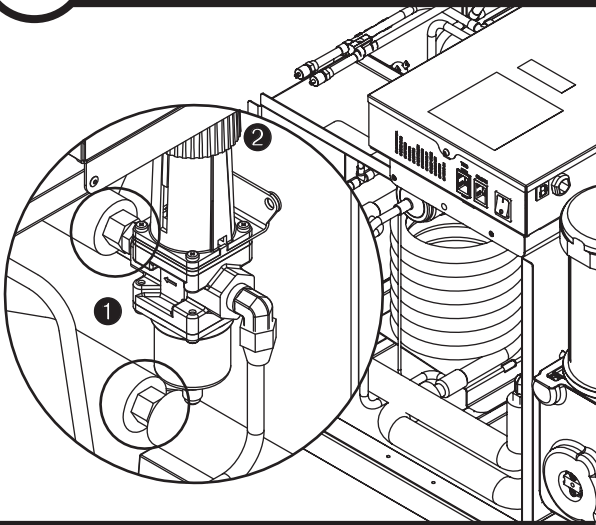

- Connect cooling water lines to ice machine (Water "Out" connects to water regulator.) ①
- Water valve is set at the factory. **DO NOT** remove seal or adjust water valve ②

7.10 Power cord

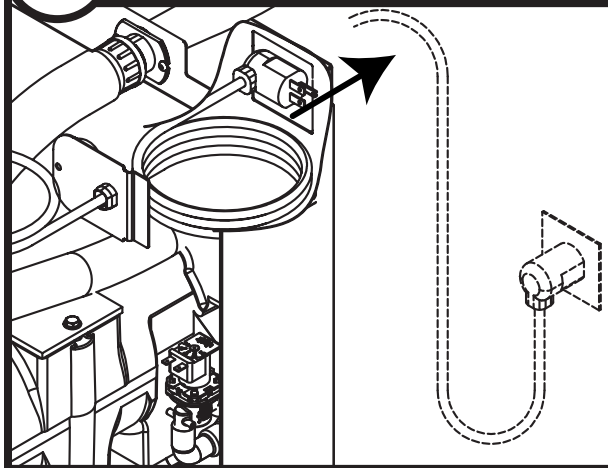

- Remove twist tie
- Carefully pass cord thru opening and plug into wall outlet
- For H_E units, install a suitable plug

7.11 Power cord

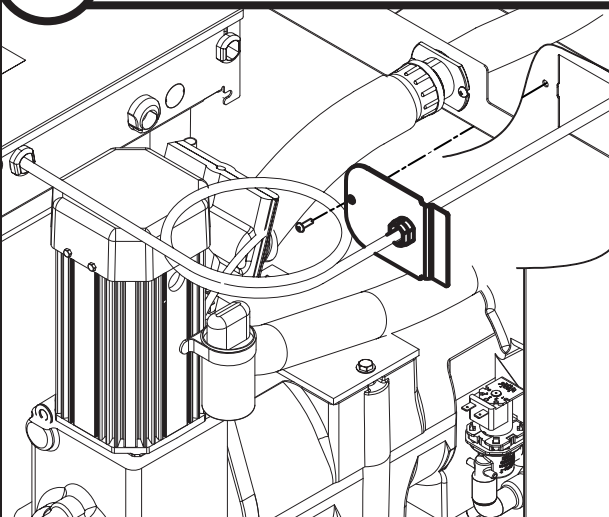

- Position plate into opening and secure with supplied screw

7.12 TDS switch

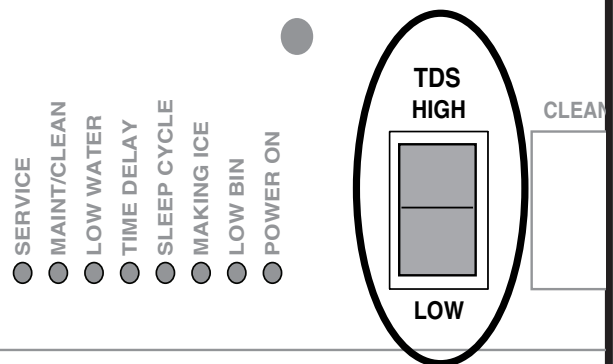

- Set the TDS switch on the electrical box:
HIGH: for extended service life
LOW: for low-scale water

Install front cover to ice machine.

Front cover **8**

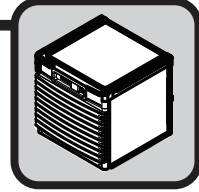

Front cover installation – air-cooled undercounter only

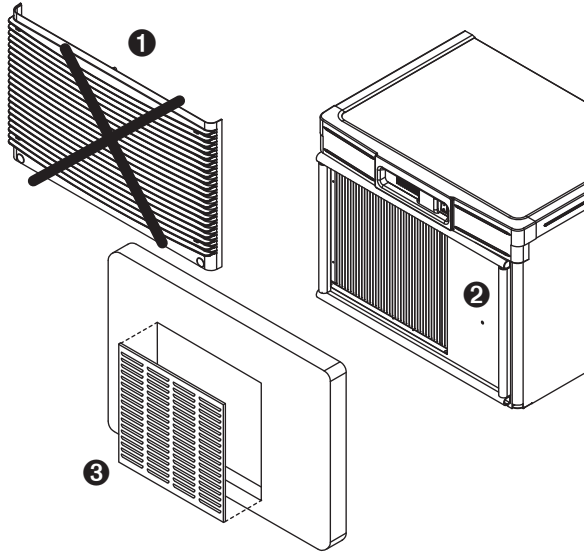

CAUTION

- Keep ventilation openings in the appliance enclosure clear of obstruction.
- To ensure proper ventilation (if not using supplied grille) carefully review air circulation specifications in section 4.1

- Remove and discard plastic grille **1**
- Apply supplied gasket material around entire opening on skin to prevent air recirculation **2**
- Attach supplied metal grille to opening in counter door (see section 4.1) **3**

Install front cover

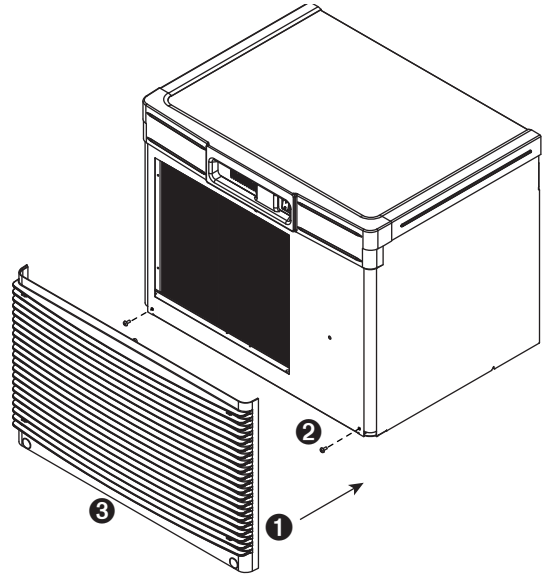

- Slide ice machine cover over machine ensuring that tabs on back of cover slip under louvers on back of docking assembly **1**
- Insert and tighten two screws through cover and into docking assembly **2**
- For air-cooled machines only, install plastic grill **3**

NOTICE

Ice machine MUST be sanitized prior to operation!

Consult Operation and Service Manual provided with ice machine for sanitizing instructions.

Long tube run recommendations

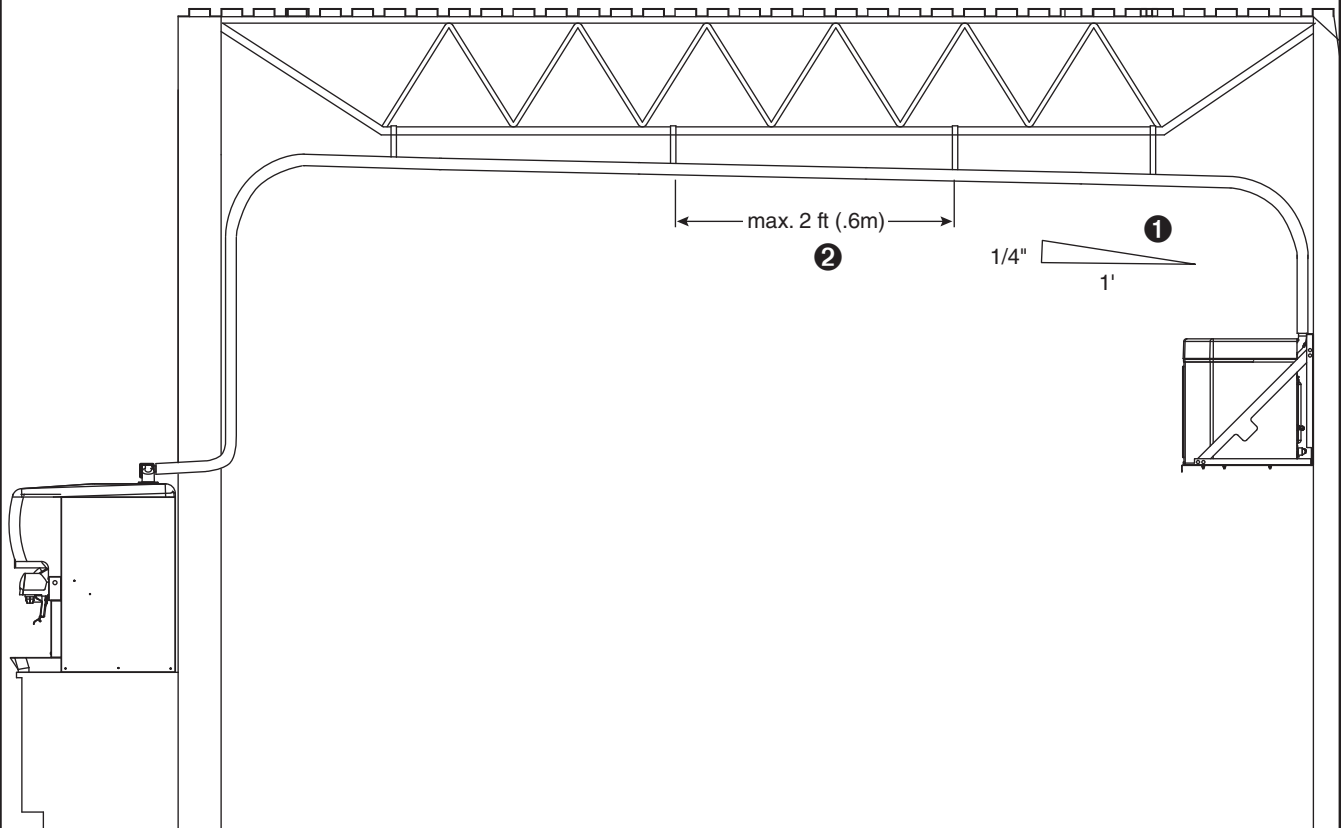

- Pitch ice transport tube to allow melt water to drain towards ice machine ①
- Secure insulated ice transport tube at least every 2 ft (0,6m) to prevent dips or traps ②

Maestro, Vision, Ice Manager, Horizon Elite are trademarks of Follett Products, LLC.
Chewblet, RIDE, Follett are registered trademarks of Follett Products, LLC.

FOLLETT[™]

801 Church Lane • Easton, PA 18040, USA
Toll free (877) 612-5086 • +1 (610) 252-7301
www.follettice.com

01113281R06
© Follett Products, LLC 11/24