

# Maestro Plus™

## C 425 series ice machine for healthcare applications

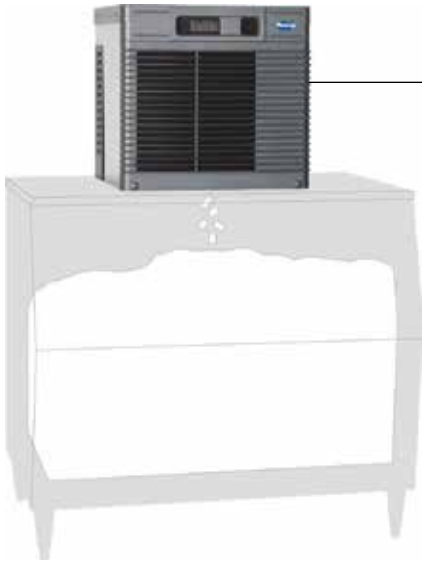

Model MCC425ABT shown



### Features

Maestro Plus ice machine with up to 193 kg (425 lb) daily production of consumer-preferred Chewblet® or flake ice.

#### High performance Maestro Plus ice machines

- compact, reliable ice machine for top mount installation
- stainless steel evaporator, auger and top bearing
- oversized, heavy duty, tapered roller bearing ensures long low-maintenance life
- automatic self-flushing of ice machine for superior scale control
- no noisy harvest cycles means quiet ice production

#### Lower utility bills

- energy-efficient, no costly defrost cycles
- meets 2018 Department of Energy regulations
- 40% less water than comparable capacity cube machines

#### Maintenance and service benefits

- cleaning and sanitizing of entire machine takes less than 1 hour
- LED control board provides at-a-glance machine status

#### Flake ice (MFC models) is the required ice for clinical labs, rehab and medical research

- high surface area of flake ice chills quickly, maintains samples at desired temperature
- holds test tubes and lab vials securely, even when ice is melting
- molds well in ice bag and rehab applications for best skin contact and swelling control

#### Consumer-preferred Chewblet ice (MCC models)

- chewable, compressed nugget ice is preferred over cubes<sup>1</sup>
- available with approximately 1.00" (2.54 cm) long standard Chewblet ice or optional 3/8" (0.95 cm) long Micro Chewblet™ ice
- more reliable dispensing than nugget or pellet ice
- slow melting, maintains drink temperature and quality, comparable to cubes
- higher displacement than cube ice

#### Installation flexibility

- Top kits allow ice machine to be top mounted on most ice and beverage dispensers
- Top kits install without any alteration to dispenser (kit includes stainless steel top)
- compatible with over 20 of Follett's ice storage bins

#### Warranty

- 3 years parts and labor, 5 years compressor parts<sup>2</sup>

<sup>1</sup> Consumer study conducted by independent agency Roper ASW.

<sup>2</sup> Refer to price list for additional warranty information.

Model configurations				
Ice type	For use with <sup>1</sup>	Condenser	V/Hz <sup>2</sup>	Item number
<b>Flake</b>	ice storage bin	air	220/60	<b>MFC425ABT</b>
		water	220/60	<b>MFC425WBT</b>
<b>Chewblet®</b>	ice storage bin	air	220/60	<b>MCC425ABT</b>
		water	220/60	<b>MCC425WBT</b>
	ice and beverage dispenser (by others)	air	220/60	<b>MCC425AHT</b>
<b>Micro Chewblet</b>	ice storage bin	air	220/60	<b>MMC425ABT</b>
		water	220/60	<b>MMC425WBT</b>

<sup>1</sup> Ordered separately.

<sup>2</sup> Alternate voltage not for use in the United States.

## Accessories

Water filters (refer to form# 1058)

Additional Maestro Plus accessories (refer to price list)

## Specification for bin top mount ice machines

<b>W1</b> Width	57.6 cm (22.70") fits on 22.00" wide dispensers or bins
<b>D1</b> Depth, ice machine	61.6 cm (24.25")
<b>D2</b> Depth, bin door	80.0 cm (31.50")
<b>H1</b> Height	54.0 cm (21.25")
Service clearance	30.5 cm (12.00") top - no front obstructions 15.24 cm (6.00") on exhaust side (left, right and rear)
<b>C1</b> 220 V/60/1 electrical	5.5 amps, 0.8 kW 2.4 m (8') cord only
<b>C2</b> Water inlet	3/8" FPT installation of an in line water filtration system is recommended
<b>C3</b> Drain	3/4" MPT water-cooled models require separate condenser drains
Water-cooled ice machine connections	<b>C4</b> – 3/8" FPT condenser inlet <b>C5</b> – 3/8" FPT condenser drain
Refrigerant	R404a
Air temperature	10 - 38 C (50 - 100 F)
Water temperature	7 - 32 C (45 - 90 F)
Potable water pressure	69 - 483 kPa (10 - 70 psi)
Condenser water pressure	69 - 861 kPa (10 - 125 psi)
Chewblet ice production at 21 C (70 F) air, 10 C (50 F) water	air-cooled models – 193 kg (425 lb) water-cooled models – 201 kg (442 lb)
Chewblet ice production at 32 C (90 F) air, 21 C (70 F) water	air-cooled models – 150 kg (330 lb) water-cooled models – 167 kg (368 lb)
Flake ice production at 32 C (90 F) air, 21 C (70 F) water	air-cooled models – 225 kg (495 lb) water-cooled models – 234 kg (515 lb)
Energy consumption 32 C (90 F) air, 21 C (70 F) water	air-cooled models – 5.4 kWh water-cooled models – 5.0 kWh per 45.4 kg (100 lb) ice
Heat rejection	air-cooled models – 5,000 BTU/hr water-cooled models – 1400 BTU/hr to air, 3600 BTU/hr to water
Water consumption	45.4 L (12.0 gal) of potable water per 45.4 kg (100 lb) of ice (per AHRI test standards). 47.3 L (12.5 gal) at standard flush setting.
Water flow requirement for water-cooled condensers	0.25 gpm at 10 C (50 F) 0.5 gpm at 21 C (70 F) 1.25 gpm at 32 C (90 F)
Approximate ship weight	77 kg (170 lb)

### NOTES:

For indoor use only.

Configure with a Follett bin. Refer to slope front spec sheet, form# 9135.

SHORT FORM SPECIFICATION: Ice machine to be Follett model number \_\_\_\_\_ . Ice machine to produce \_\_\_\_ Chewblet, \_\_\_\_ Micro Chewblet or \_\_\_\_ flake ice. Ice machine to have stainless steel evaporator, auger and top bearings, heavy-duty tapered roller bearings, and low water safety circuit. NSF listed.

## Dimensional drawing

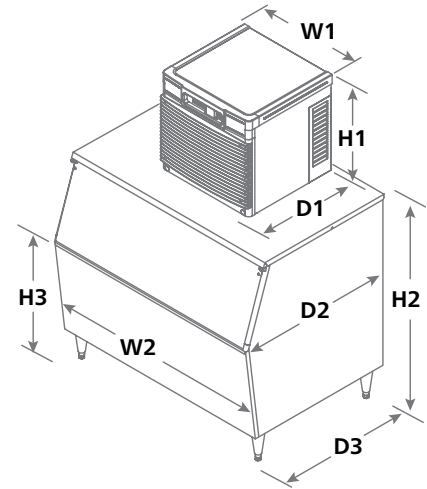

Back view – air-cooled, top mount

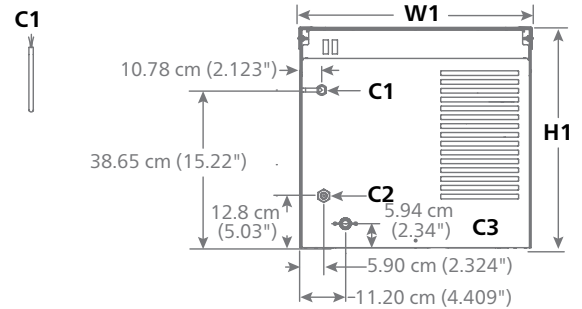

Back view – water-cooled, top mount

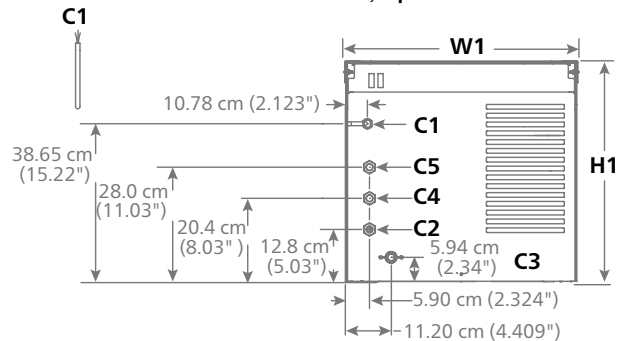

## Specification for ice and beverage dispenser top mount ice machines

<b>W1</b> Width	57.6 cm (22.70") fits on 22.00" wide dispensers
<b>D1</b> Depth	61.6 cm (24.25")
<b>H1</b> Height	54.0 cm (21.25")
Service clearance	30.5 cm (12.00") top - no front obstructions 15.24 cm (6.00") on exhaust side (left, right and rear)
<b>C1</b> 220 V/60/1 electrical	5.5 amps, 0.8 kW 2.4 m (8') cord only
<b>C2</b> Water inlet	3/8" FPT, installation of an in line water filtration system is recommended
<b>C3</b> Drain	3/4" MPT
Refrigerant	RR404a
Air temperature	10 - 38 C (50 - 100 F)
Water temperature	7 - 32 C (45 - 90 F)
Potable water pressure	69 - 483 kPa (10 - 70 psi)
Condenser water pressure	69 - 861 kPa (10 - 125 psi)
Ice production at 21 C (70 F) air, 10 C (50 F) water	193 kg (425 lb)
Ice production at 32 C (90 F) air, 21 C (70 F) water	150 kg (330 lb)
Energy consumption 32 C (90 F) air, 21 C (70 F) water	5.4 kWh per 45.4 kg (100 lb) ice
Heat rejection	5,000 BTU/hr
Water consumption	45.4 L (12.0 gal) of potable water per 45.4 kg (100 lb) of ice (per AHRI test standards). 47.3 L (12.5 gal) at standard flush setting.
Approximate ship weight	77 kg (170 lb)
NOTE: For indoor use only	

SHORT FORM SPECIFICATION: Ice machine to be Follett model number \_\_\_\_\_. Ice machine to produce Chewblet ice. Ice machine to have stainless steel evaporator, auger and top bearings, heavy-duty tapered roller bearing, and low-water safety circuit. NSF listed.

## Dimensional drawing

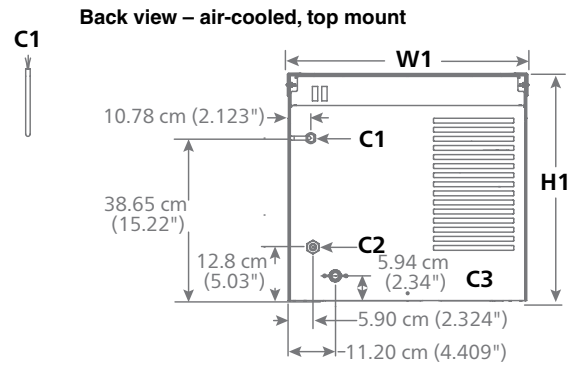
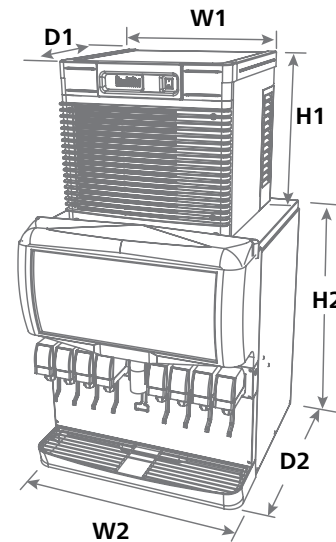

Manufacturer/ Model number	W2 = Width cm (in)	D2 = Depth cm (in)	H2 <sup>1</sup> = Height cm (in)	Top kit
<b>Coca-Cola dispensers</b>				
Freestyle 7000 <sup>2,3</sup>	76.5 (30.10)	84.1 (33.11)	119.4 (47.00)	MTF30SCP
Freestyle 7100 <sup>2,4</sup>	76.2 (30.00)	88.8 (33.80)	119.4 (47.00)	MTF30SCP
Freestyle 9000 <sup>2</sup>	64.8 (25.50)	90.2 (35.50)	187.3 (73.75)	MTF24SCP
Freestyle 9100 <sup>2</sup>	64.8 (25.50)	99.7 (39.25)	196.2 (77.25)	MTF26SCP
<b>Cornelius dispensers</b>				
DB/DF/ED150 series	55.9 (22.00)	76.2 (30.0)	87.3 (34.38)	MTC22SCP
DB/DF/ED175 series	62.2 (24.50)	76.2 (30.0)	87.3 (34.38)	MTC24SCP
DB/DF/ED200 series	76.2 (30.00)	76.2 (30.0)	87.3 (34.38)	MTC30SCP
DB/DF/ED250 series	76.2 (30.00)	76.2 (30.0)	97.5 (38.38)	MTC30SCP
<b>Lancer dispensers</b>				
4500-22N, FS-22N	55.9 (22.00)	77.5 (30.50)	92.7 (36.50)	MTL22SCP
4500-30N	76.2 (30.00)	77.5 (30.50)	92.7 (36.50)	MTL30SCP
FS-30N	76.2 (30.00)	77.5 (30.50)	107.0 (42.13)	MTL30SCP
Lancer Sensation	76.2 (30.00)	78.7 (31.00)	97.2 (38.25)	MTL30SCP
Lancer Touchpoint	82.6 (32.50)	85.6 (33.70)	101.6 (40.00)	MTL30SCP
<b>Pepsi dispensers</b>				
Spire 3.0	68.6 (27.00)	88.9 (35.00)	96.8 (38.12)	MTP24SCP
Spire 5.0 / 4.1	77.5 (30.50)	91.4 (36.00)	108.6 (42.75)	MTP30SCP

<sup>1</sup> Net height after installation of top kit.

<sup>2</sup> Consult with Coca-Cola and Follett to qualify application prior to ordering.

<sup>3</sup> Top adapter IC Code 46412 and ice kit IC Code 46430 must also be ordered from Coca-Cola.

<sup>4</sup> Top adapter IC Code 46753 and ice kit IC Code 46430 must also be ordered from Coca-Cola.

## Chewblet ice production – air-cooled models

Inlet water temperature C (F)	Ambient air temperature C (F)					kg (lb) production in 24 hr
	16 (60)	21 (70)	27 (80)	32 (90)	38 (100)	
10 (50)	206 (454)	193 (425)	181 (398)	165 (363)	149 (328)	
16 (60)	198 (437)	185 (408)	172 (379)	157 (346)	143 (314)	
21 (70)	191 (420)	177 (390)	163 (359)	150 (330)	136 (300)	
27 (80)	182 (401)	170 (374)	158 (348)	145 (319)	132 (290)	
32 (90)	173 (381)	163 (359)	153 (337)	140 (308)	127 (280)	

## Chewblet ice production – water-cooled models

Inlet water temperature C (F)	Condenser water temperature C (F)					kg (lb) production in 24 hr
	16 (60)	21 (70)	27 (80)	32 (90)	38 (100)	
10 (50)	206 (454)	201 (442)	196 (431)	190 (419)	185 (408)	
16 (60)	197 (435)	191 (421)	185 (407)	179 (394)	173 (380)	
21 (70)	189 (416)	182 (400)	174 (384)	167 (368)	159 (351)	
27 (80)	180 (396)	173 (381)	166 (365)	159 (350)	152 (335)	
32 (90)	170 (375)	164 (361)	157 (346)	151 (332)	144 (318)	

MAESTRO PLUS and MICRO CHEWBLET are trademarks of Follett Products, LLC.  
 CHEWBLET and FOLLETT are registered trademarks of Follett Products, LLC, registered in the US.  
 Follett reserves the right to change specifications at any time without obligation. Certifications may vary depending on country of origin.

Maestro Plus C 425 top mount healthcare

