



7UC100A



7UD100A

## Welcome to Follett

Follett equipment enjoys a well-deserved reputation for excellent performance, long-term reliability and outstanding after-the-sale support. To ensure that this equipment delivers that same degree of service, review this guide carefully before you begin your installation.

Should you need technical help, please call our Technical Service group at (877) 612-5086 or (610) 252-7301.

Please have your model number, serial number and complete and detailed explanation of the problem when contacting Technical Service.

## Getting Started

After uncrating and removing all packing material, inspect the equipment for concealed shipping damage. All freight is to be inspected upon delivery. If visible signs of damage exist, please refuse delivery or sign your delivery receipt "damaged." Follett Customer Service must be notified within 48 hours. Wherever possible, please include detailed photos of the damage with the original packaging so that we may start the freight claim process.

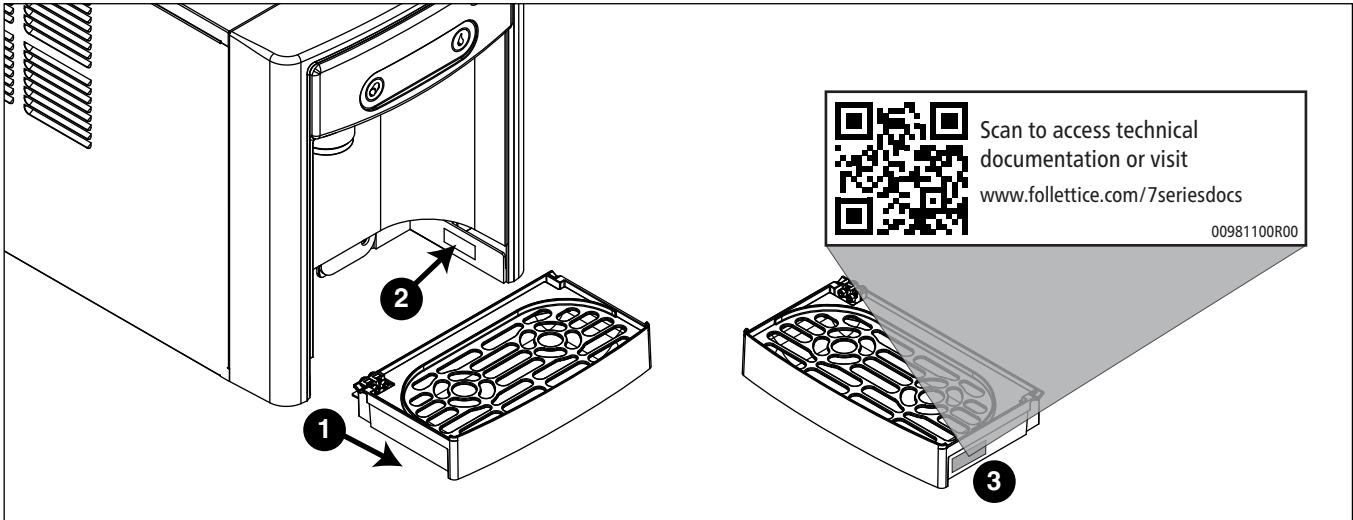


# Contents

<b>Welcome to Follett</b> .....	<b>1</b>
Getting Started .....	1
<b>Before You Begin</b> .....	<b>4</b>
<b>Important Safety Information</b> .....	<b>4</b>
<b>Specifications</b> .....	<b>5</b>
Dimensions .....	5
Ambient Information .....	5
Plumbing .....	5
Water .....	5
Clearances .....	5
Electrical .....	5
Refrigeration .....	5
Heat Rejection .....	5
Detailed Drawing .....	6
<b>Installation</b> .....	<b>7</b>
<b>Maintenance/Cleaning Mode</b> .....	<b>9</b>
<b>Accessing Internal Components</b> .....	<b>9</b>
<b>Filter Display Indicator Activation</b> .....	<b>10</b>
<b>Cleaning and Sanitizing Procedure</b> .....	<b>11</b>
<b>Service</b> .....	<b>12</b>
LED Indicator Description .....	12
Evaporator Disassembly .....	13
Evaporator Assembly .....	16
Water Feed Schematic .....	20
Bin Melt Water/Evaporator Feed/Clean Out System Schematic .....	21
Vent System Schematic .....	21
Refrigeration Schematic .....	22
Condenser Fan Motor Removal .....	23
User Interface Display Identification .....	24
Electrical Wiring Diagram .....	25
Exterior .....	26
Interior .....	28
Bin Assembly .....	30
Evaporator Assembly .....	32

## Before You Begin

If needed, the serial number of your dispenser can be found by removing the drip tray ❶ and locating the serial number label ❷. A QR Code is located on the right hand side of the drip tray ❸. This code allows you to access manuals, technical bulletins, and on-line training related to the 7 Series dispensers.



Check your paperwork to verify that you received the correct dispenser. Follett configuration numbers are designed to provide information about the type of dispenser you are receiving. The following is an explanation of the different model numbers.

Dispenser Storage Capacity	Configuration	Ice machine Capacity	Condenser
7 lb	UC Undercounter UD Undercounter - ADA	100 lb per day	A Air-cooled

## Important Safety Information

Please read and adhere to the following safety information while installing, using, or servicing your Follett 7 Series Ice Dispenser.

1. Always disconnect power before servicing the dispenser.
2. Ice is slippery. Maintain counters and floors around dispenser in a clean and ice-free condition.
3. Ice is food. Follow the recommended cleaning and sanitizing instructions to maintain cleanliness of delivered ice.

# Specifications

## Dimensions

	7UC100A	7UD100A
Width	14.55" (370 mm)	14.55" (370 mm)
Depth	22.05" (560 mm)	22.05" (560 mm)
Height	33.50" (851 mm)	31.50" (800 mm)
Unit Shipping Weight	110 lb (50 kg)	110 lb (50 kg)

## Ambient Information



### CAUTION!

The 7UC100A and 7UD100A are for indoor use only.

	Maximum*	Minimum*
Air Temperature†	100 F (38 C)	50 F (10 C)
Water Temperature	90 F (32.2 C)	40 F (4.5 C)
Water Pressure	70 psi	10 psi
Relative Humidity	55% at 78 F (25.5 C)	

\* Use outside of these limitations is misuse and will void warranty.  
† Best performance is achieved between 80 F (27 C) and 50 F (10 C).

## Plumbing

- Water Inlet: 1/4" MPT or John Guest push-in fitting
- Optional Drain Accessory Kit (item# 00956375 or 00981977): 1/2" ID tubing
- Water shut-off recommended within 5 ft (1.5 m) of dispenser

## Water



### WARNING!

Connect to potable water supply only.

- Water Mineral Content:
  - TDS: greater than 5 ppm (mg/l) but less than 400 ppm (mg/l)
  - Hardness: Less than 200 mg/l (12 gpg)
- Not recommended for use with softened water

## Clearances

- 3" (7.62 cm) behind dispenser for electrical and optional drain connection.
- 6" (15.3 cm) in front of dispenser for ventilation.

## Electrical

- 115V, 60 Hz, 1 phase, 5A, maximum fuse 15A
- Connect to dedicated 15A circuit, fuse or breaker
- Must be grounded - requires 3-prong outlet. Do not remove ground.

## Refrigeration



### WARNING!

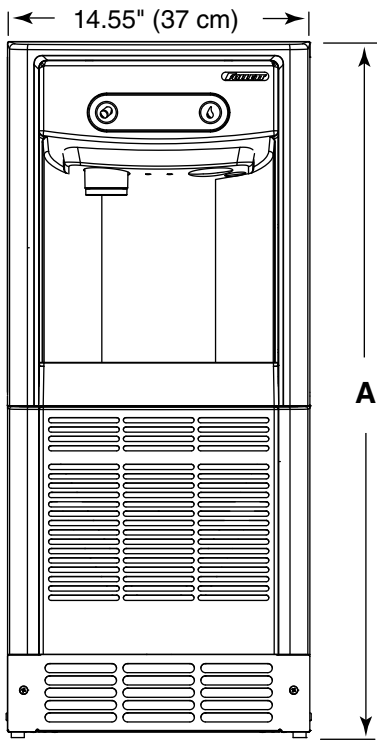
Do not damage the refrigerant circuit. Refrigerant can cause personal injury and/or damage dispenser.

- Refrigerant R134a – 5.0 ounces (142 grams)

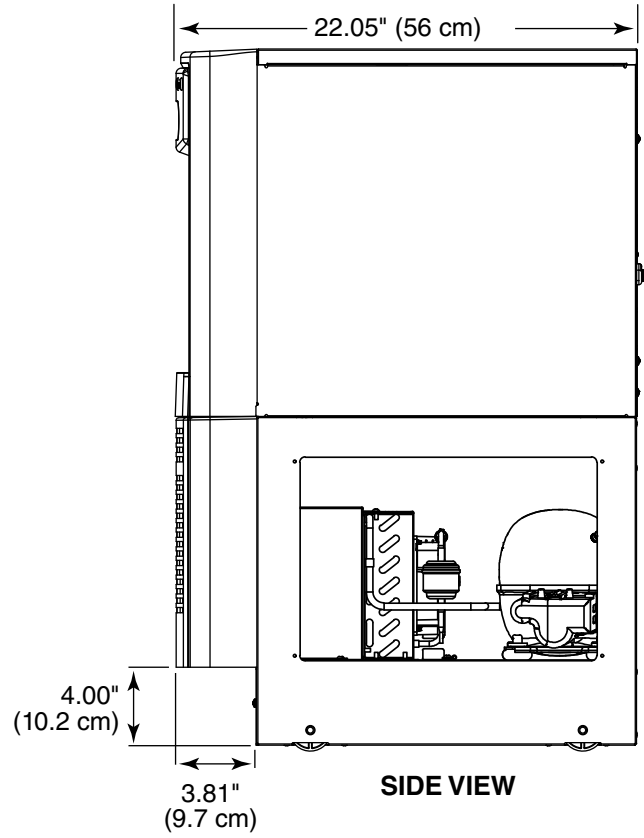
## Heat Rejection

- 1700 BTU/hr (498 W)

# Detailed Drawing

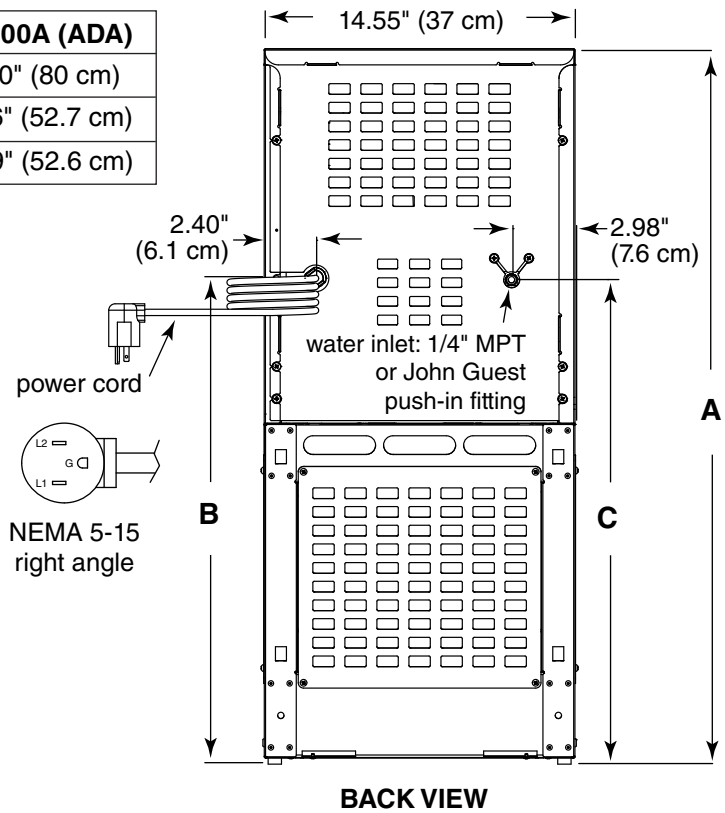


**FRONT VIEW**



**SIDE VIEW**

Dimension	7UC100A	7UD100A (ADA)
<b>A</b>	33.50" (85.1 cm)	31.50" (80 cm)
<b>B</b>	22.76" (57.8 cm)	20.76" (52.7 cm)
<b>C</b>	22.69" (57.6 cm)	20.69" (52.6 cm)



**BACK VIEW**

## Installation

### CAUTION!

No service or maintenance should be performed until the technician has thoroughly read this service manual. Except for routine cleaning and sanitizing, only qualified technicians should attempt to service or maintain this equipment.

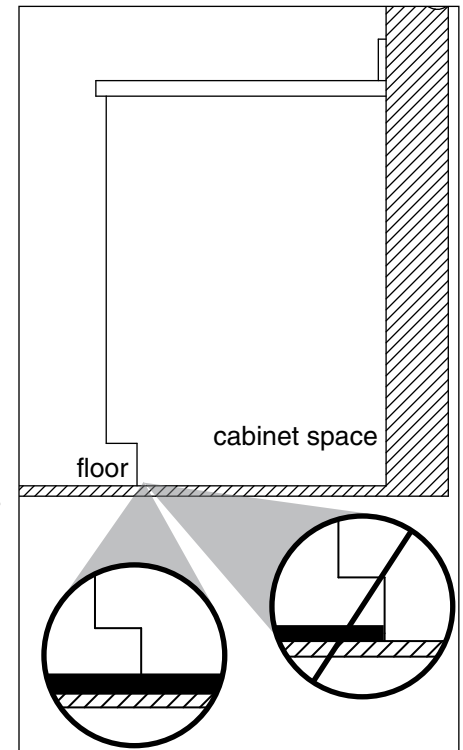
1. Measure to verify that the dispenser will fit in the desired location. A clearance of at least 3" (7.62 cm) is required behind the dispenser for the electrical and optional drain connection.
2. Ensure that the finished floor inside the cabinet is flush (level) with the floor outside the cabinet (**Fig. 1**). If the cabinet floor is lower than the finished floor, the cabinet floor must be built up (using appropriate materials) until it is flush with the finished floor. A flush floor is required for proper operation and maintenance/service of the dispenser.
3. Rough-in the electrical service, water line, and optional Drip Tray Drain Kit\*.

**Note:** The dispenser must be installed such that it can be moved forward at least 4" (10.2 cm) to allow access to the Bin Lid Cleaning Spout (**Fig. 9.6**) for dispenser cleaning and sanitizing. Take this requirement into consideration during rough-in.

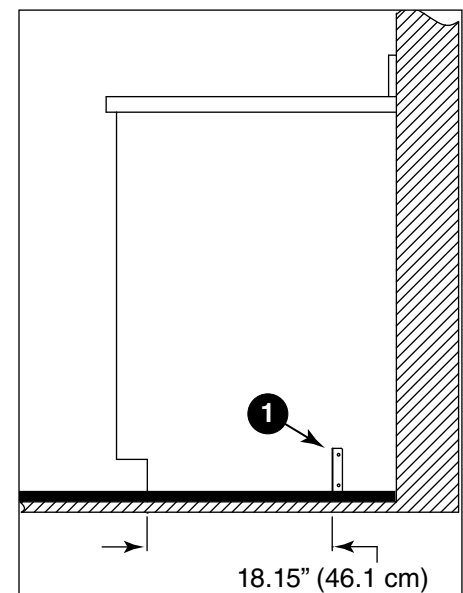
- Electrical: 115 V, single phase, 15A receptacle required. The dispenser has an integral 8 ft (2.4 m) cord and plug.
- Water: supply line (with shut-off valve) connects to the dispenser's 1/4" MPT or John Guest push-in fitting inlet.
- \* The optional Drip Tray Drain Kit (item# 00956375) requires a floor drain within 15 ft (4.5 m) of the dispenser. For detailed installation instructions, please refer to the instructions shipped with the Drip Tray Drain Kit.

4. Install the angle bracket inside the cabinet, 18.15" (46.1 cm) from the toe kick (**Fig. 2.1**). The bracket prevents the dispenser from being located/pushed beyond the recommended cabinet space depth. **Do not attach the bracket to the dispenser.**

**Fig. 1**

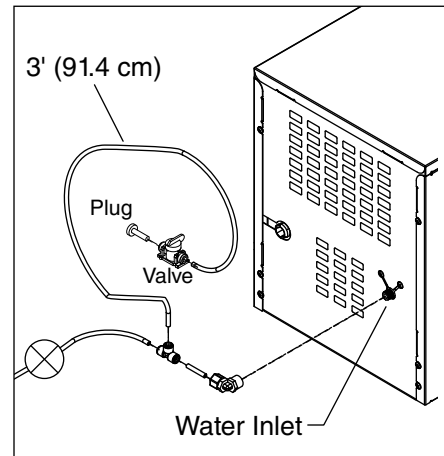


**Fig. 2**



5. Connect water line. Recommended routing (**Fig. 3**) allows easy access to water for cleaning and sanitizing procedure.

**Fig. 3**

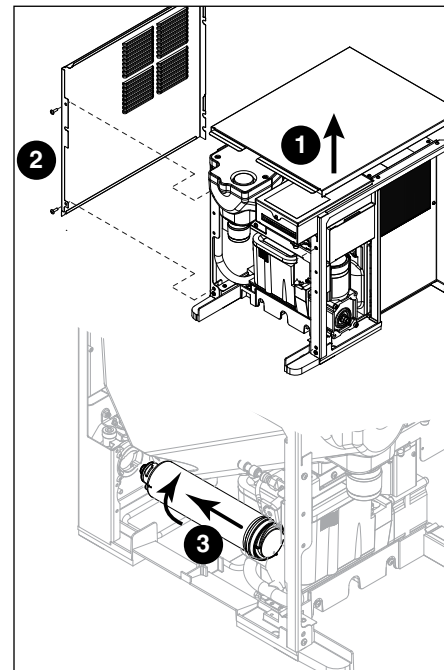


6. If installing the optional internal water filter\*, please complete the steps shown in **Cleaning and Sanitizing Procedure on page 11** before proceeding. If not, proceed to step 10.

\* If your dispenser has the internal water filter option, the water filter *must* be installed for the dispenser to operate. Because internal components will need to be accessed for both procedures, Follett recommends installing the water filter just prior to initial sanitizing.

7. Lift and remove the top panel, set aside (**Fig. 4.1**).
8. Remove two screws (**Fig. 4.2**) and remove left side panel.
9. Install filter as shown. Turn filter clockwise until it is fully seated (**Fig. 4.3**).
10. Connect power supply.
11. Sanitize the dispenser prior to use (see **Cleaning and Sanitizing Procedure on page 11**).

**Fig. 4**





## Maintenance/Cleaning Mode



### Cleaning Mode (Dispensing Disabled) - Use when cleaning surface

Entering Cleaning Mode disables the User Interface and allows you to clean the outside of the dispenser without accidentally dispensing water or ice.

1. To enter Cleaning Mode, press and immediately release the maintenance/clean switch (**Fig. 5.1**) so that only "FRESH FILTERED ICE AND WATER" displays in the user interface (**Fig. 5.2**).
2. To exit Cleaning Mode, press and immediately release the maintenance/clean switch so that the ice and water icons also display in the user interface.

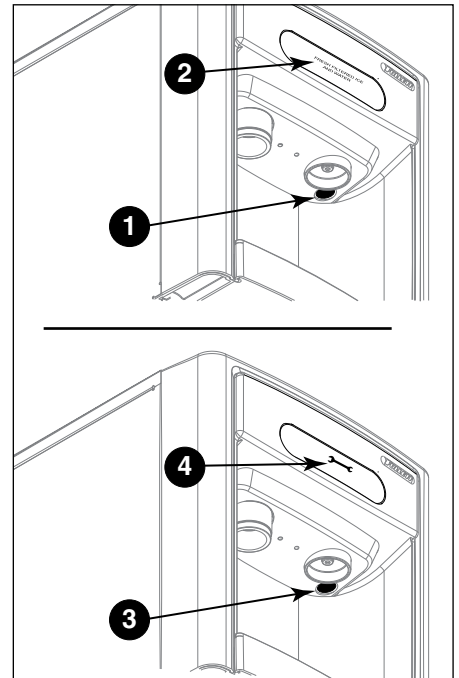
### Maintenance Mode (All Operation Disabled) - Use when cleaning ice machine

Entering Maintenance Mode disables all operations and allows you to safely clean and/or sanitize the ice machine and dispenser.

1. To enter Maintenance Mode, press and hold the maintenance/clean switch (**Fig. 5.3**) until  displays in the user interface (**Fig. 5.4**).
2. To exit Maintenance Mode, press and hold the maintenance/clean switch until  no longer displays in the user interface.

**Note:** Entering and exiting Maintenance Mode will reset the six-month periodic maintenance reminder.

Fig. 5



## Accessing Internal Components

### CAUTION!

*Except for routine cleaning and sanitizing, only qualified technicians should attempt to service or maintain this equipment.*


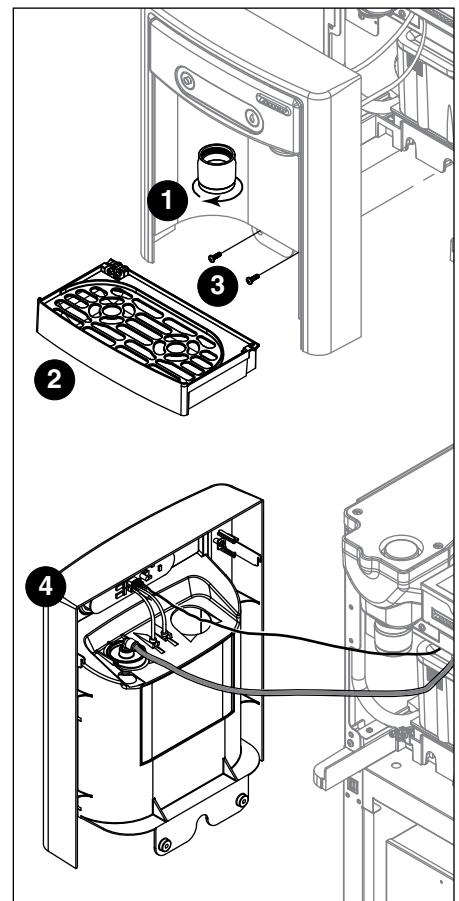
1. Press and hold the maintenance/clean switch (**Fig. 5.1**) until  displays in the user interface (**Fig. 5.2**).
2. Remove (unscrew) chrome ice dispenser chute (**Fig. 6.1**).
3. Remove the drip tray (**Fig. 6.2**).
4. Remove the two screws (**Fig. 6.3**) on the front panel (behind the drip tray).
5. Remove and set aside the front panel (**Fig. 6.4**). **Do not disengage the plug on the back of the User Interface or the tubing at the water dispenser chute (if so equipped).**

Fig. 6



# Filter Display Indicator Activation

If you purchased your dispenser with a Follett filter, the filter display indicator activation has been preset at the factory.

If you are using an “after market filter,” an adjustment may be made to activate the “Fresh Filtered Ice & Water” display.

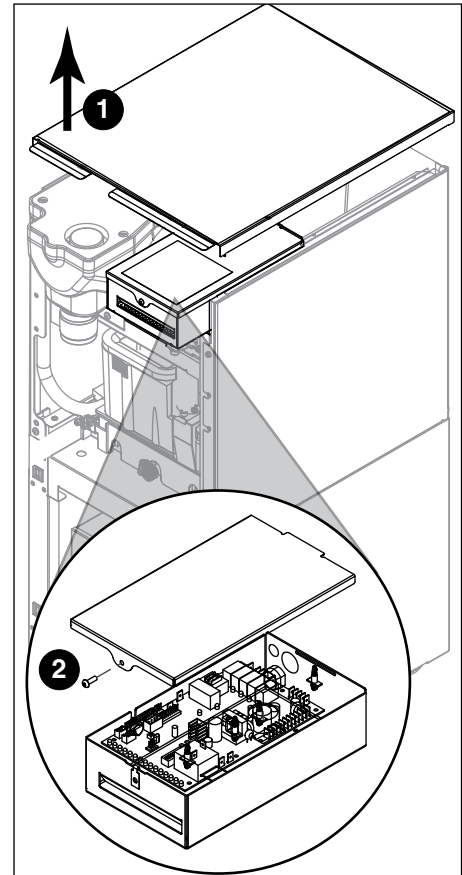
## Activating “Fresh Filtered Ice & Water”

1. Remove the front panel as explained in [Accessing Internal Components on page 9](#) then refer to **Fig. 7**.
2. Remove top panel (**Fig. 7.1**).
3. Remove (1) screw and top of control board enclosure (**Fig. 7.2**).
4. Locate the DIP switches on the dispenser's control board (**Fig. 8**). Use a fine-pointed object to move the “Filter” DIP switch (DIP switch #3) to the ON position.

## Deactivating the Six-Month Maintenance/Filter Change Reminder

1. Use a fine-pointed object to move the “PM” DIP switch (DIP switch #8) to the ON position.

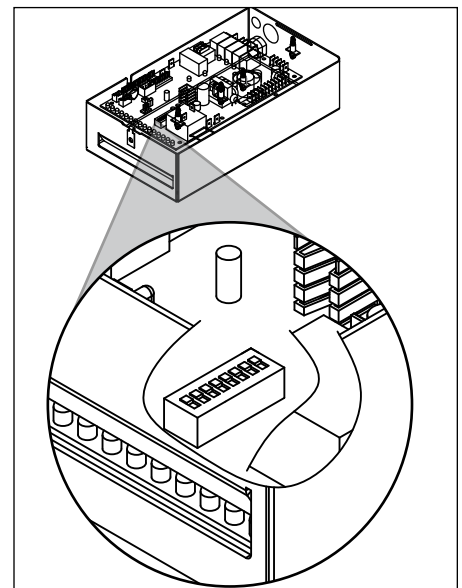
**Fig. 7**



	OFF	ON	
Not used (OFF position)	<input type="checkbox"/>	<input type="checkbox"/>	1
Ice only	<input type="checkbox"/>	<input type="checkbox"/>	2
No internal filter	<input type="checkbox"/>	<input type="checkbox"/>	3
Not used (OFF position)	<input type="checkbox"/>	<input type="checkbox"/>	4
Not used (OFF position)	<input type="checkbox"/>	<input type="checkbox"/>	5
15 minute delay	<input type="checkbox"/>	<input type="checkbox"/>	6
Not used (OFF position)	<input type="checkbox"/>	<input type="checkbox"/>	7
Six-month PM enabled	<input type="checkbox"/>	<input type="checkbox"/>	8

Ice and water  
Internal filter supplied or to display "Fresh Filtered"  
30 minute delay  
Six-month PM disabled

**Fig. 8**



## Cleaning and Sanitizing Procedure

Cleaning and sanitizing should be performed at least every 6 months (more often if local water conditions dictate). For initial startup, only sanitizing is required.

**IMPORTANT!** Prior to cleaning and sanitizing, the dispenser must be moved forward at least 4" (10.2 cm). Do not remove the Bin Lid, cleaning and sanitizing solution is added through the Bin Lid Access Spout (**Fig. 9.6**).




### **WARNING!**

- Place the dispenser in Maintenance Mode prior to servicing or cleaning the ice machine. See [Maintenance/Cleaning Mode on page 9](#).
- For protection, rubber gloves and safety goggles (and/or face shield) should be worn when handling SafeCLEAN Plus™.
- Do not use bleach, it will damage the dispenser.

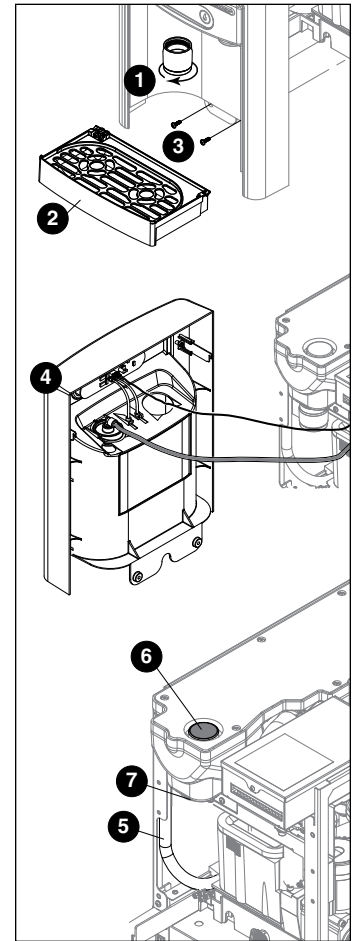
### Required Supplies

- **7 Series:** Follow the directions on the SafeCLEAN Plus packaging to mix 3 gal (11.4 L) of Follett SafeCLEAN Plus solution. Use 100 F (38 C) water.
- **15 Series:** Follow the directions on the SafeCLEAN Plus packaging to mix 6 gal (22.7 L) of Follett SafeCLEAN Plus solution. Use 100 F (38 C) water.
- Funnel, bucket, 100 F (38 C) potable water

### Ice machine and Dispenser

1. Dispense all the ice out of the unit.
2. Press and hold maintenance/clean switch until  displays in the user interface to enter Maintenance Mode.
3. Remove (unscrew) chrome ice dispense chute (**Fig. 9.1**).
4. Remove drip tray (**Fig. 9.2**).
5. Remove (2) screws located behind the drip tray (**Fig. 9.3**).
6. Move front panel and place on top or beside unit (**Fig. 9.4**).
7. Remove plug cap from the end of drain tube (**Fig. 9.5**) and lower tube to drain water into bucket. After the system has been drained of water replace plug cap in drain tube.
8. Secure tube in holder.
9. Remove cap from bin lid cover (**Fig. 9.6**).
10. Screw bin lid cover cap onto ice discharge chute (**Fig. 9.7**).
11. Pour SafeCLEAN Plus solution into bin lid access spout until solution reaches the spout neck.
12. Allow the SafeCLEAN Plus solution to remain in unit for 15 minutes.
13. While machine is cleaning, remove top and right side panel to access and clean air-cooled condenser.
14. Submerge ice dispense chute in the remainder of SafeCLEAN Plus solution for 2 minutes. Rinse with clean, potable water.
15. Drain system by lowering drain tube into bucket.
16. Secure drain tube into holder.
17. Fill and drain twice with potable water. Secure drain tube.
18. Place a bucket under the dispense chute and remove cap. **Note:** Some SafeCLEAN Plus solution will remain and drain out when cap is removed. Reposition cap on bin lid spout.
19. Reinstall front panel, ice dispense chute, and drip tray.
20. Press and hold maintenance/clean switch to exit Maintenance Mode.

**Fig. 9**



## User Interface and Exterior Cabinet

1. Press and release maintenance/clean switch so that only "FRESH FILTERED ICE AND WATER" displays in the user interface to enter Cleaning Mode (and disable dispensing).
2. Plastic parts, including the user interface, can be cleaned with a non-abrasive glass cleaner. Clean stainless steel panels with stainless steel cleaner.
3. Press and release maintenance/clean switch to put unit back into service.

## Service

### LED Indicator Description

The LED Indicator is located behind the front panel.

Fig. 10

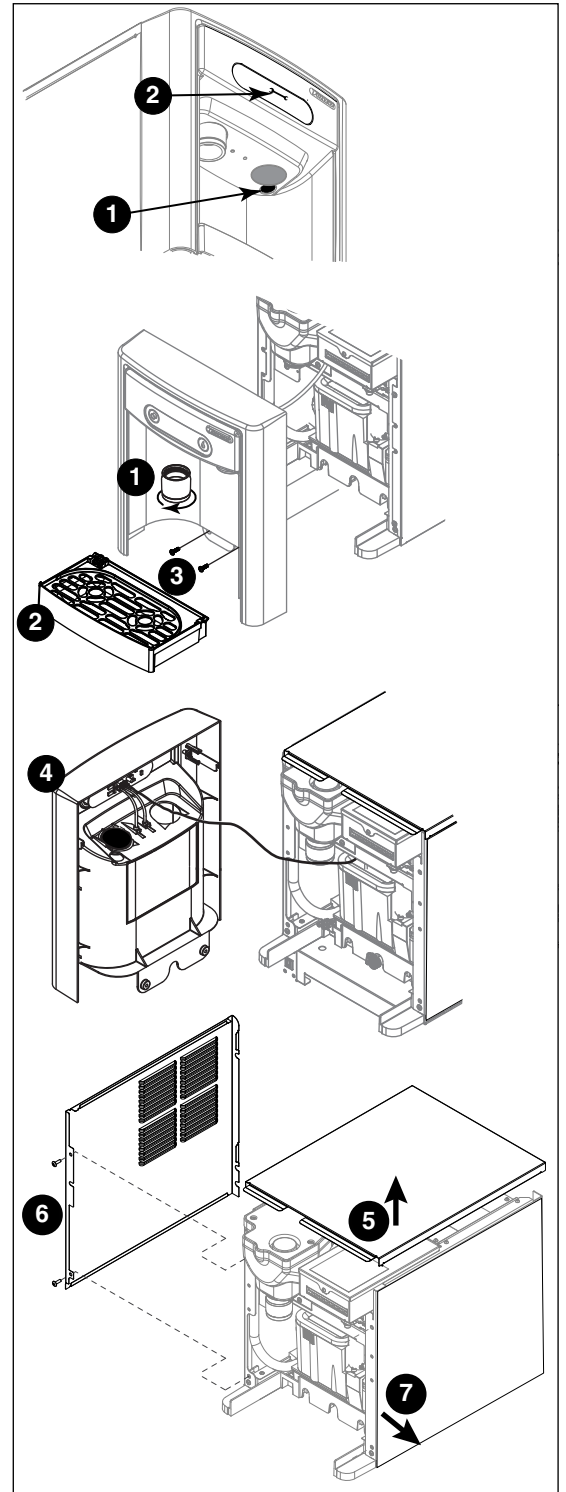


LED Name	LED Color	Description
Clean	Green	The dispenser is in Cleaning Mode. Dispenser is disabled to allow for cleaning of front panel. See <a href="#">Maintenance/Cleaning Mode on page 9</a> .
—	N/A	Not used.
PM	Red	Six-month periodic maintenance required.
Drip tray	Red	Drip tray full.
Water leak	Red	Internal leak in dispenser.
High amps	Red	Auger gearmotor has exceeded 0.55A. The HI amps and Time delay LEDs will illuminate, the machine will shut down for one hour, the LEDs will turn off, and the machine will resume normal operation.
Service	Red	8000-hour Service and maintenance check. Press and hold the reset button on the circuit board for one minute.
Maintenance	Yellow	Enter Maintenance Mode by pressing and holding maintenance/clean switch for 5 seconds. Unit will not make or dispense ice.
Low water	Yellow	Insufficient water supply to machine or no low bin LED upon startup.
Time delay	Yellow	Ice production will not resume for at least 15 minutes after a full bin is achieved and a minimum amount of dispense activity has elapsed.
Sleep cycle	Green	After a full bin and 10 minutes of non-use, the unit goes into standby and will not produce ice until either 12 hours has elapsed or ice or water has dispensed.
Making ice	Green	Gearmotor, compressor, and fan motor energized.
Low bin	Green	Bin switch closed calling for ice.
Power on	Green	Power supplied to unit.

## Evaporator Disassembly

1. Disconnect power from the dispenser.
2. Turn off water supply to dispenser.
3. Remove (unscrew) chrome ice dispenser chute (**Fig. 11.1**).
4. Remove the drip tray (**Fig. 11.2**).
5. Remove the two screws (**Fig. 11.3**) on the front panel (behind the drip tray).
6. Remove and set aside the front panel (**Fig. 11.4**). **Do not disengage the plug on the back of the User Interface.**
7. Lift and remove the top panel, set aside (**Fig. 16.5**).
8. Remove two screws (**Fig. 11.6**) and remove left side panel.
9. Remove two screws (**Fig. 11.7**) and remove right side panel.

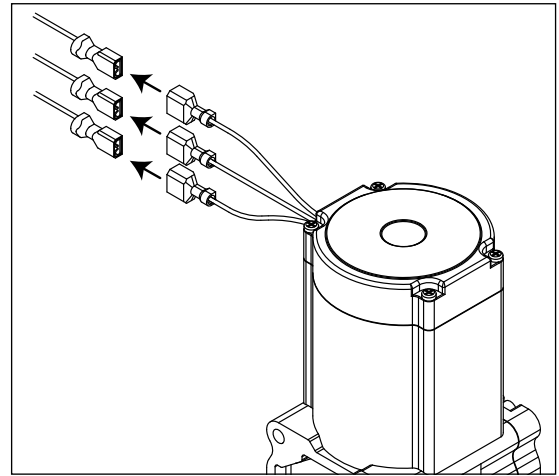
Fig. 11



10. Unplug the gear motor (three connectors) (Fig. 12).

11. Remove ground screw connection.

Fig. 12

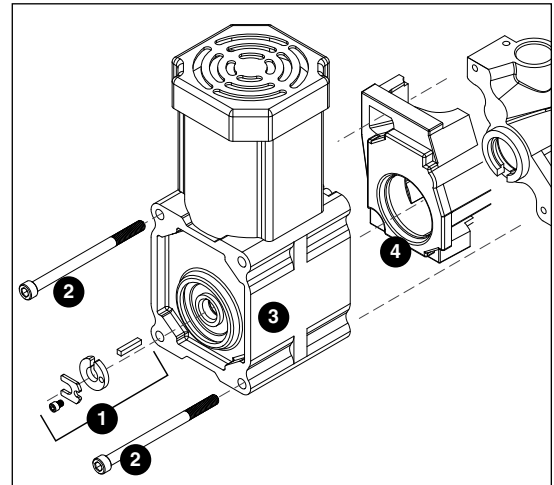


12. Remove gear motor:

- Remove M6 allen screw, retainer, spacer and key (Fig. 13.1).
- Remove two M6x90 allen screws (Fig. 13.2).
- Pull gear motor from auger (Fig. 13.3).
- Remove main housing insulation (Fig. 13.4).

13. Remove all traces of Petrol-gel from auger shaft.

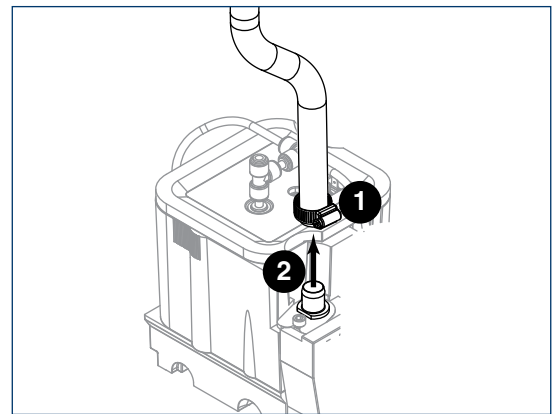
Fig. 13



14. Remove compression nozzle:

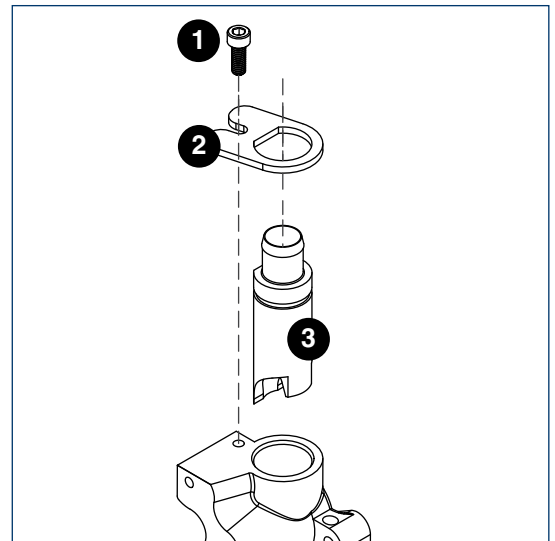
- Loosen hose clamp (Fig. 14.1).
- Remove transport tube (Fig. 14.2).

Fig. 14



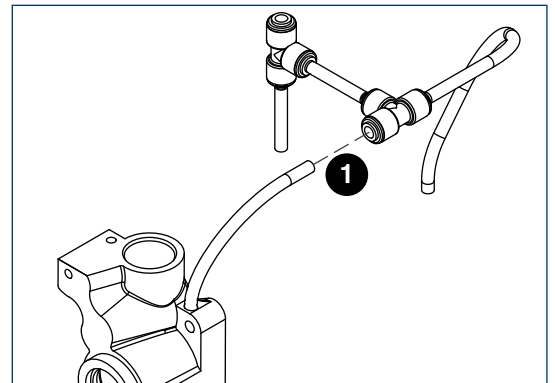
15. Remove M6 socket head allen screw (Fig. 15.1).
16. Remove compression nozzle retainer (Fig. 15.2).
17. Remove compression nozzle (Fig. 15.3).

Fig. 15



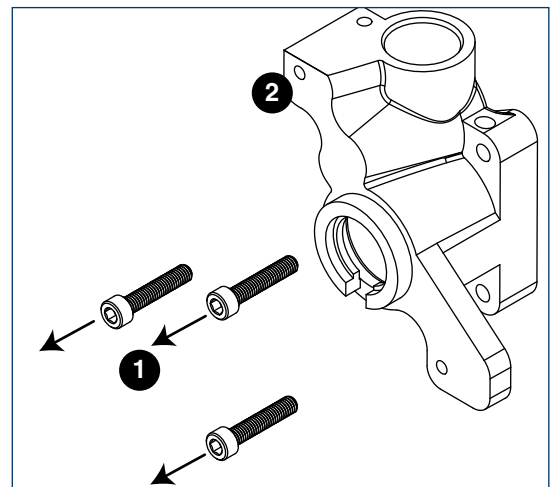
18. Remove main housing:
  - Disconnect vent line from T fitting (Fig. 16.1).

Fig. 16



19. Remove three M6x25 socket head allen screws (Fig. 17.1).
20. Remove main housing (Fig. 17.2).

Fig. 17



21. Remove and discard mating ring and seal (**Fig. 18.1**).
22. Carefully remove auger (**Fig. 18.2**).



**WARNING!**

Use caution when removing auger. The auger is very sharp - handle with care to avoid personal injury.

### Evaporator Assembly

1. Remove and inspect main housing O-ring seal. Replace if damaged in any way.
2. Clean O-ring groove. Lubricate O-ring with Petrol-gel and reinstall.
3. Use cardboard disc to press new mating ring into main housing (**Fig. 19.1**).
4. Lube the shaft with liquid soap in the area shown (**Fig. 19.2**) and slip on seal and spring (**Fig. 19.3**).

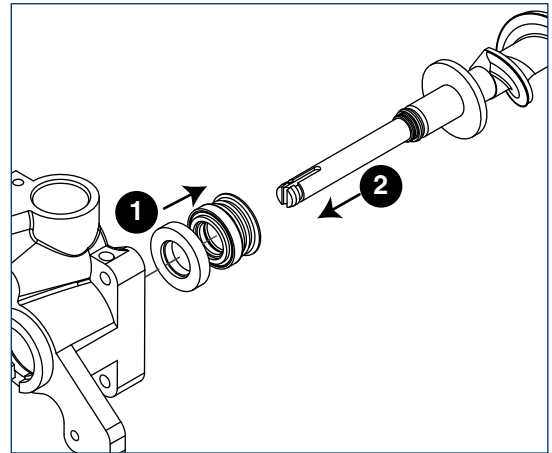
**Note:** Do not touch the sealing surfaces with bare hands. Contact with bare skin will cause premature seal failure.

5. Install auger (**Fig. 19.4**).

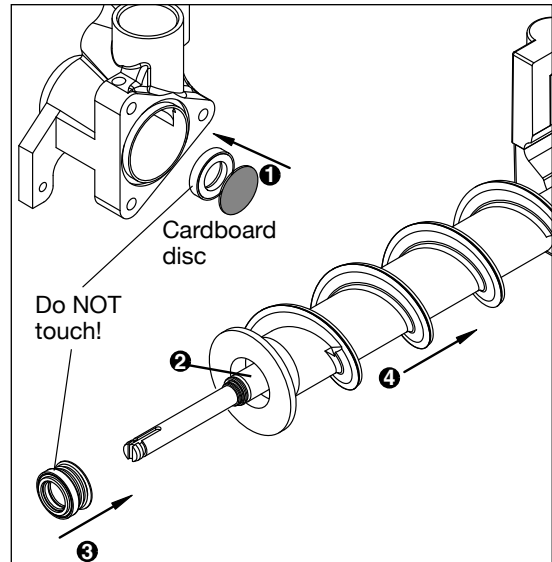
6. Install main housing:

- Slide main housing onto auger shaft (**Fig. 20.1**).
- Install three M6x25 allen screws (**Fig. 20.1**).
- Connect vent line to T fitting (**Fig. 20.1**).

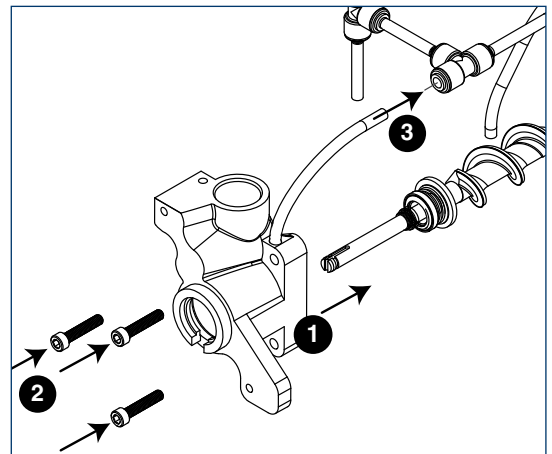
**Fig. 18**



**Fig. 19**



**Fig. 20**

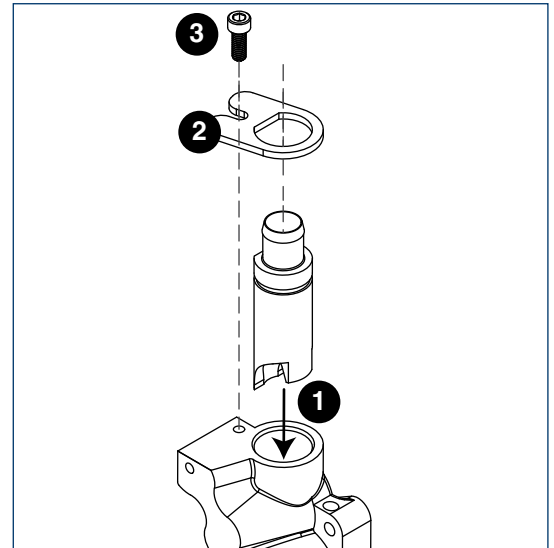




7. Install compression nozzle:

- Remove and inspect compression nozzle O-ring seal. Replace if damaged in any way.
- Clean O-ring groove. Lubricate O-ring with Petrol-gel and reinstall.
- Install compression nozzle (**Fig. 21.1**).
- Install compression nozzle retainer (**Fig. 21.2**).
- Install M6 socket head allen screw (**Fig. 21.3**).

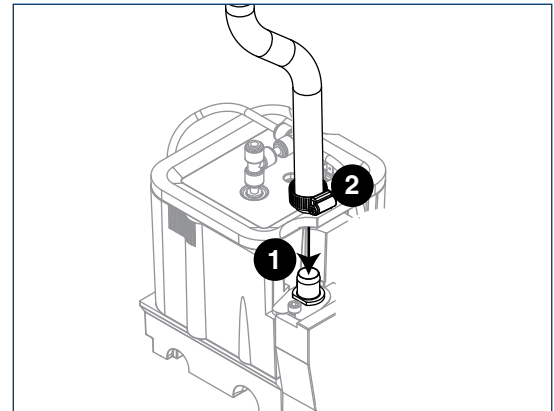
Fig. 21



8. Install transport tube (**Fig. 22.1**).

9. Tighten hose clamp (**Fig. 22.2**).

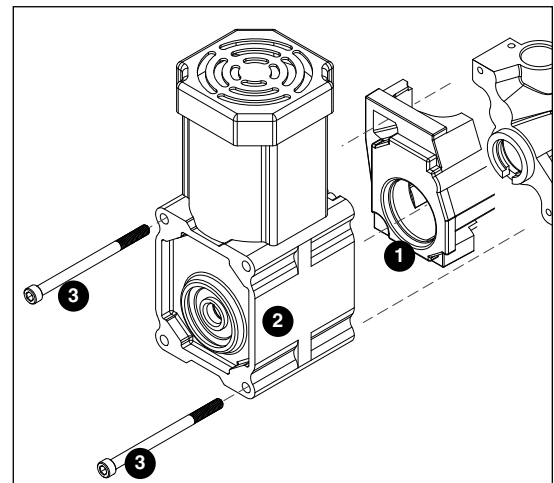
Fig. 22



10. Install gear motor:

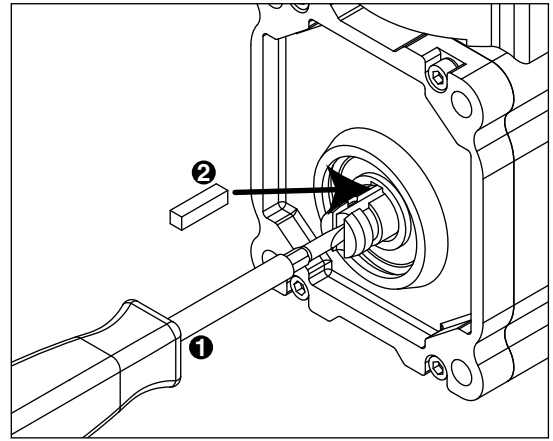
- Install main housing insulation (**Fig. 23.1**).
- Slide gear motor onto auger shaft (**Fig. 23.2**).
- Install two M6x90 allen screws (**Fig. 23.3**).

Fig. 23



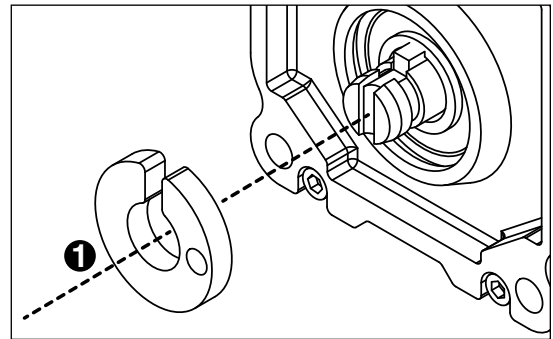
11. Use screwdriver to orient auger shaft to align with motor shaft keyway (**Fig. 24.1**).
12. Install key into keyway (**Fig. 24.2**).

**Fig. 24**



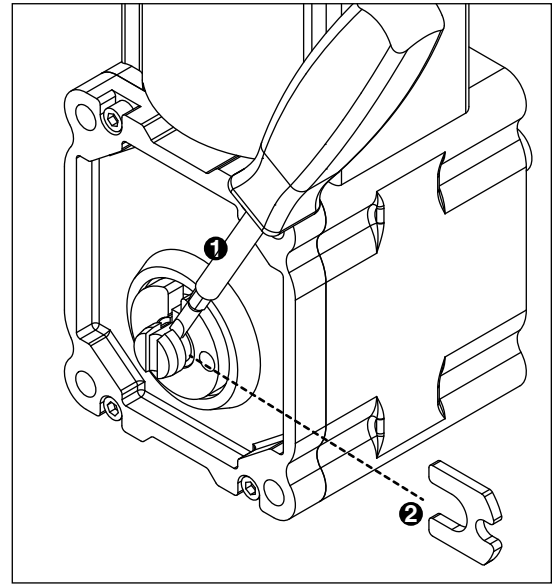
13. Install spacer, ensure that key is captured in slot (**Fig. 25.1**)

**Fig. 25**



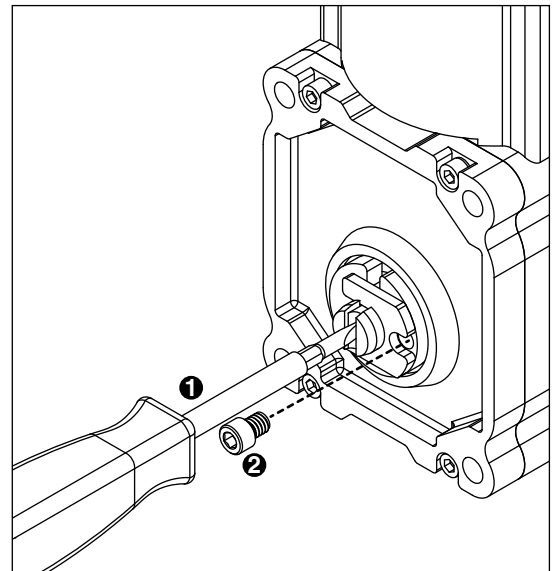
14. Insert screwdriver into groove of auger shaft and pry shaft outwards (**Fig. 26.1**).
15. Insert retainer into groove (**Fig. 26.2**), ensure that retainer is aligned with hole in spacer.

**Fig. 26**



16. Install screw and tighten (**Fig. 27.1**).

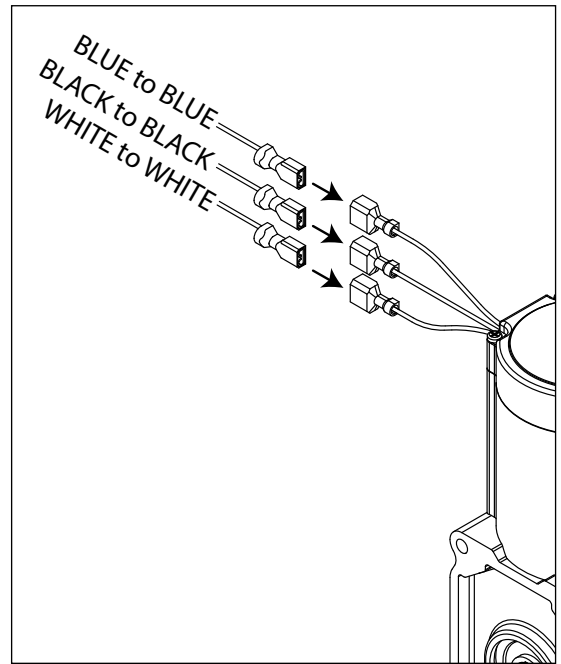
**Fig. 27**



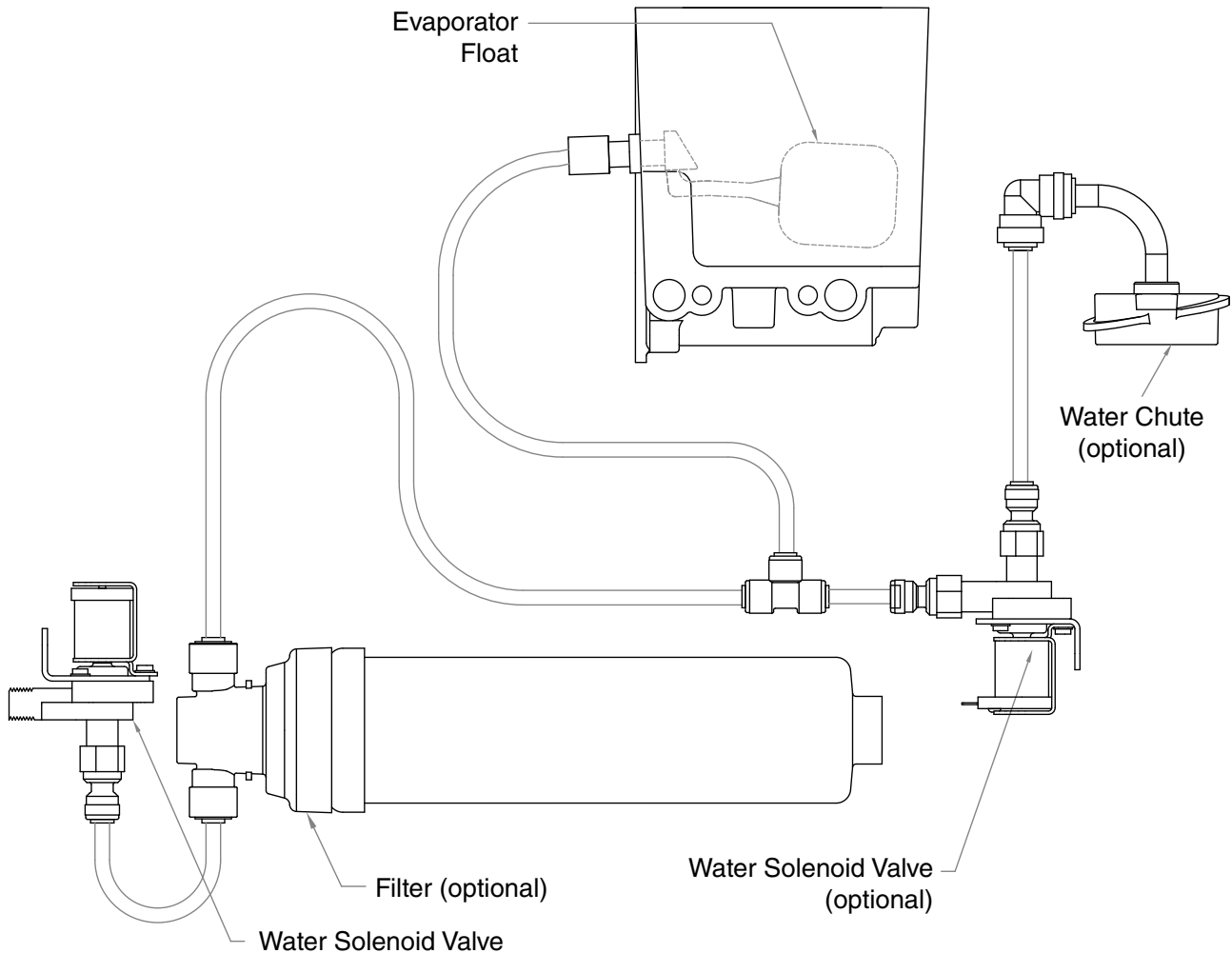
17. Plug in gear motor (Fig. 28).

- BLUE to BLUE
- BLACK to BLACK
- WHITE to WHITE
- Connect ground wire with ground screw.

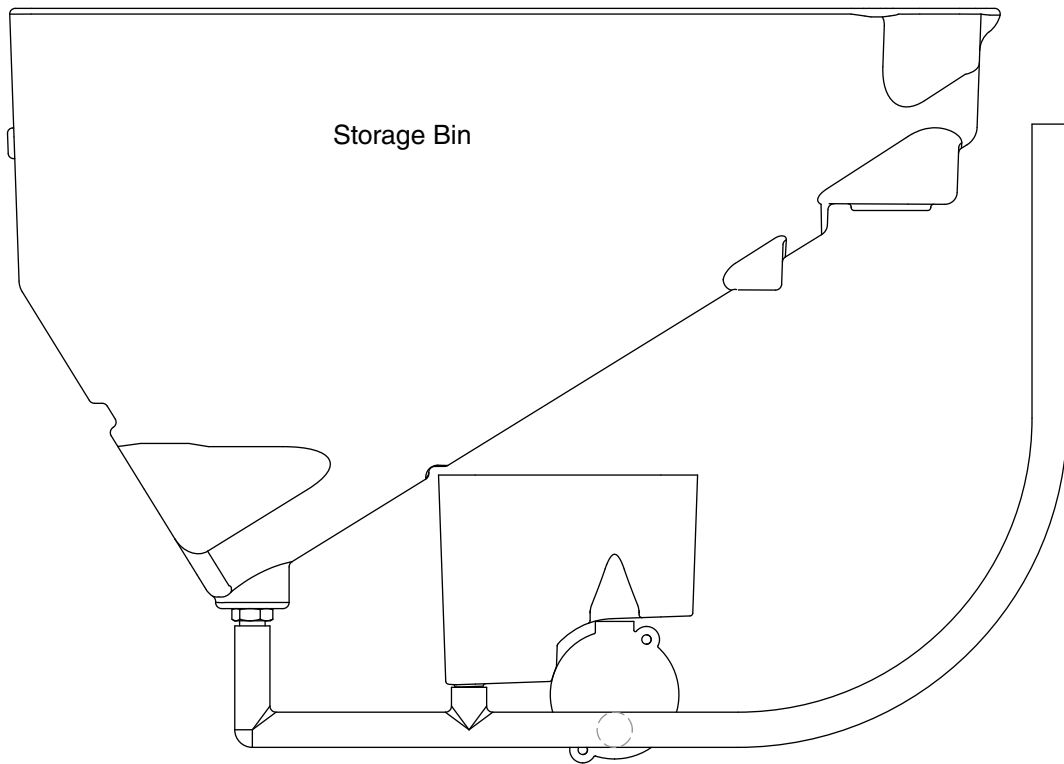
Fig. 28



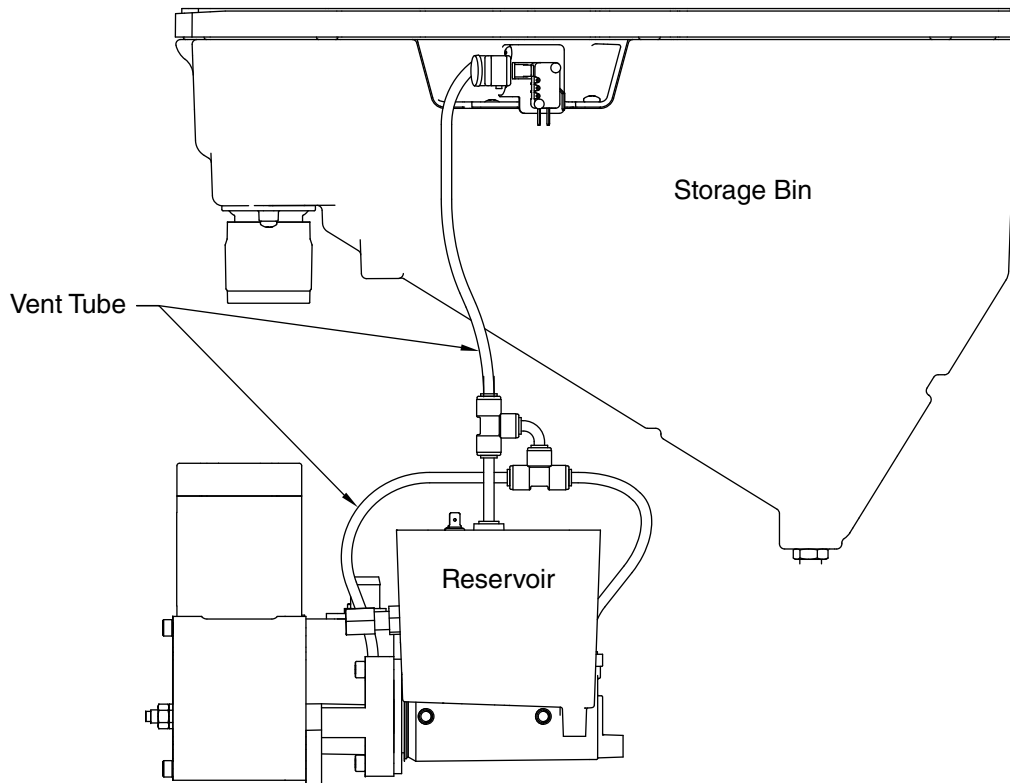
Water Feed Schematic



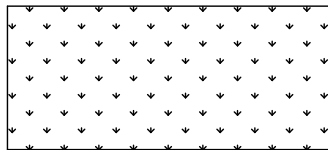
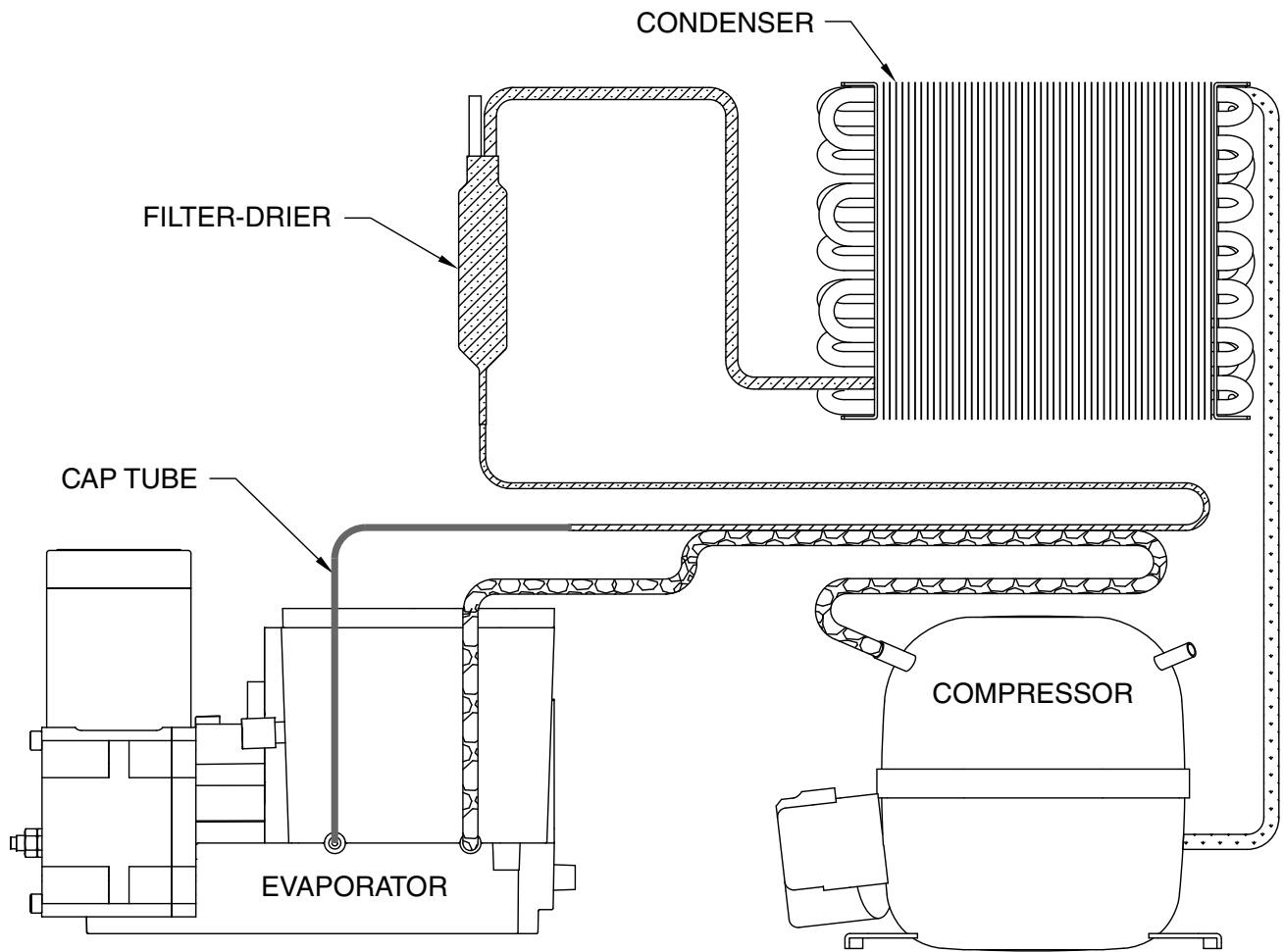
## Bin Melt Water/Evaporator Feed/Clean Out System Schematic



## Vent System Schematic



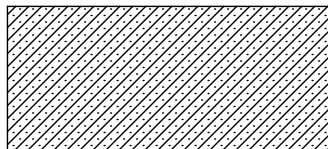
# Refrigeration Schematic



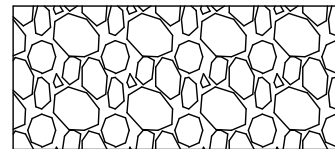
HIGH PRESSURE VAPOR



LOW PRESSURE LIQUID

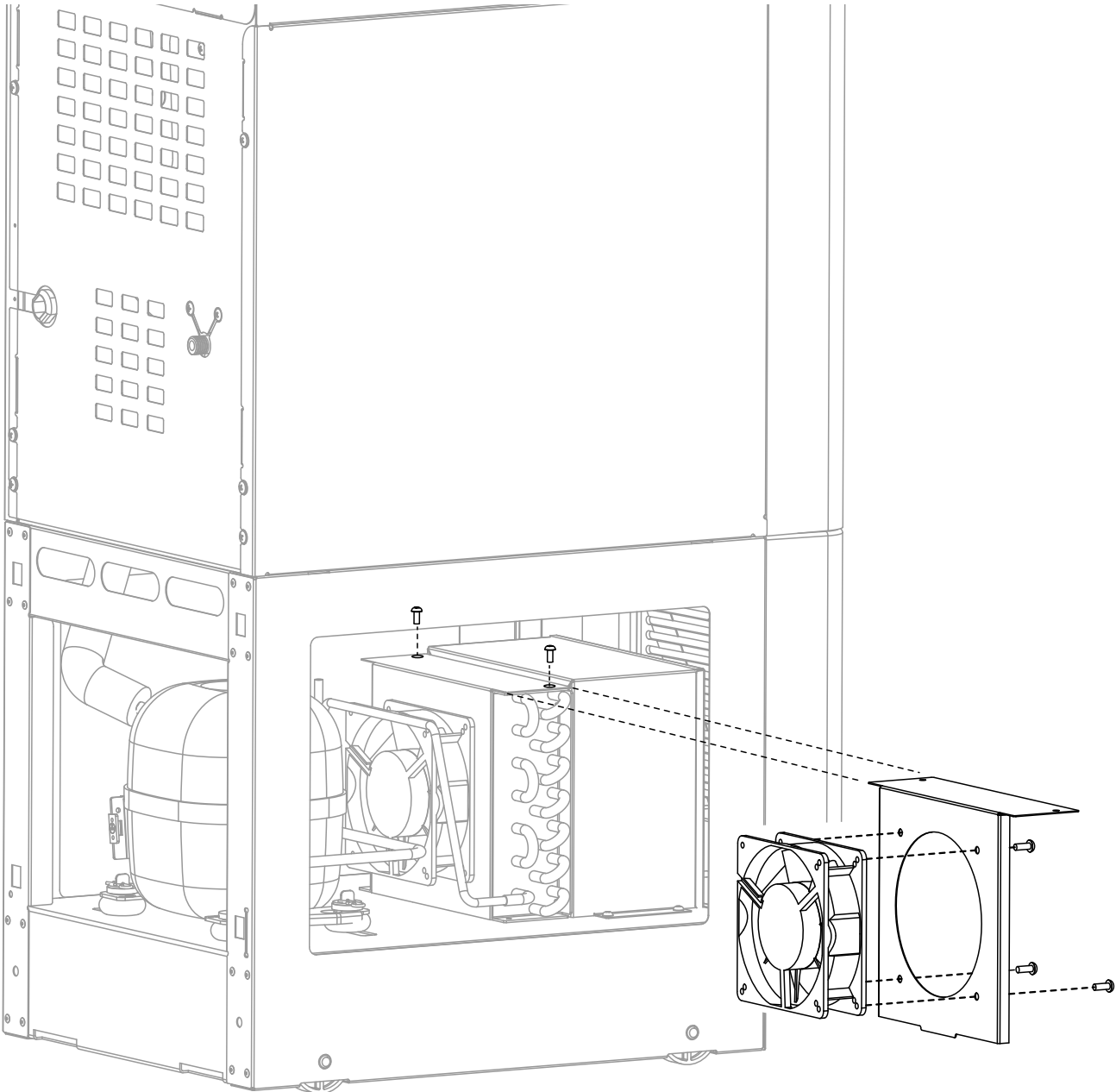


HIGH PRESSURE LIQUID


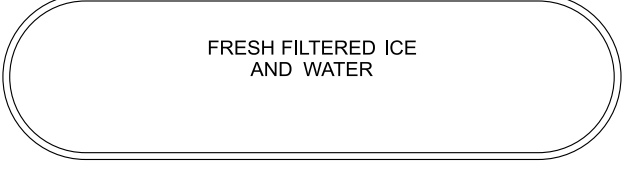

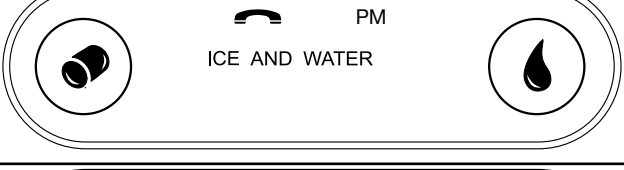
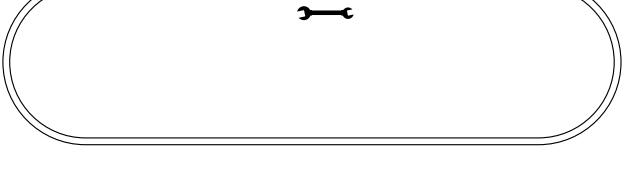


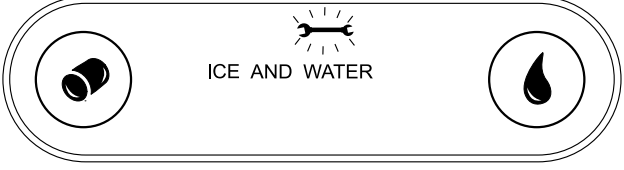
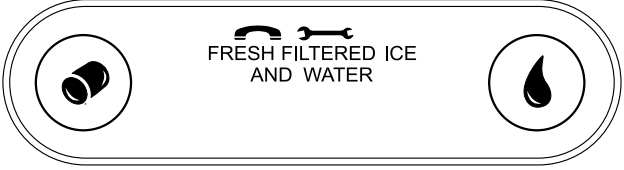

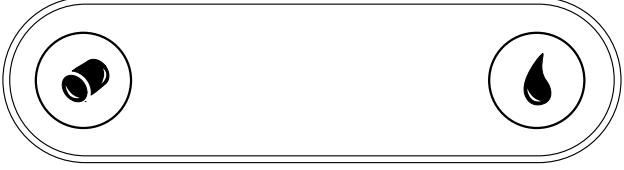


LOW PRESSURE VAPOR

# Condenser Fan Motor Removal

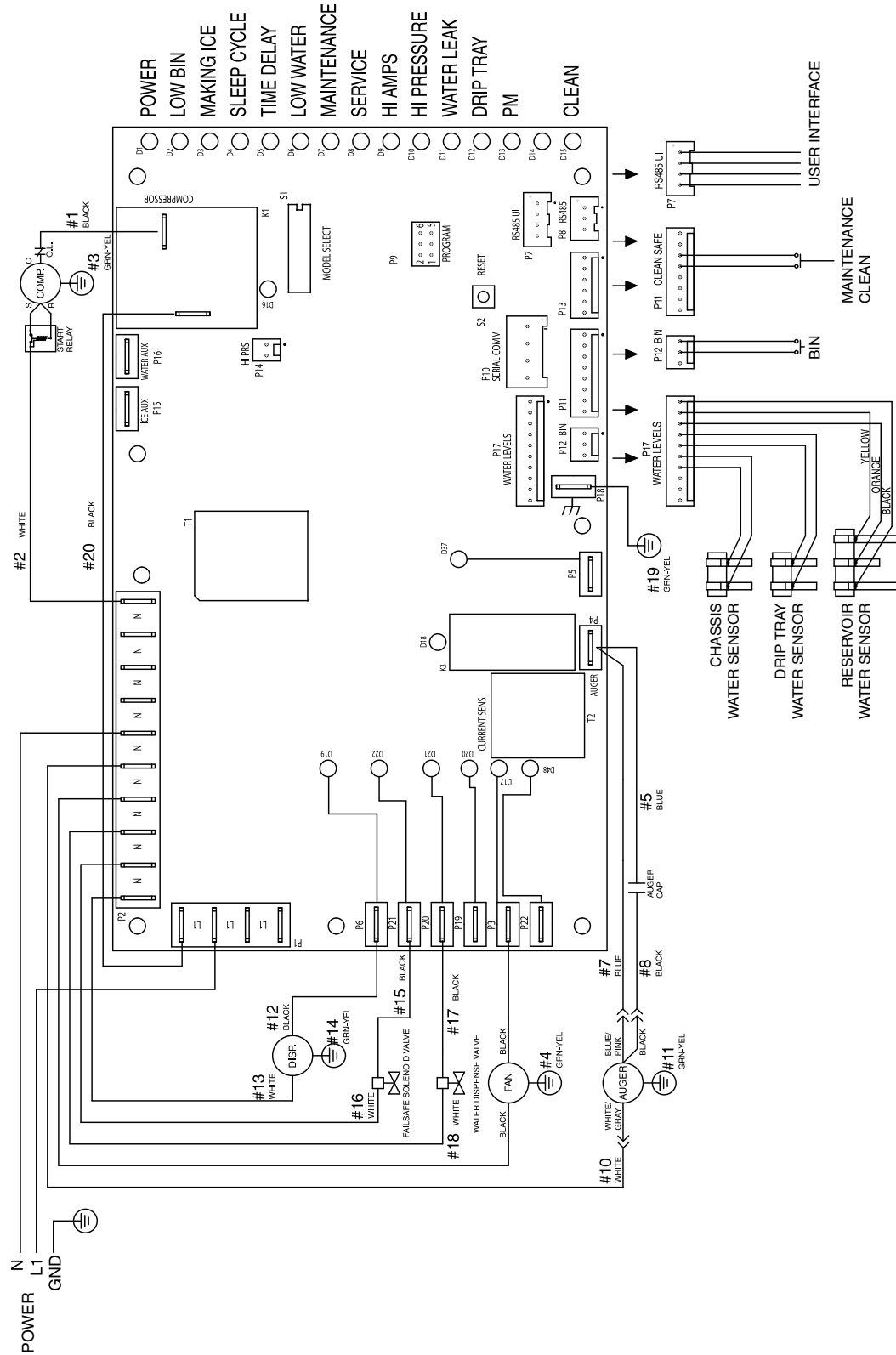


## User Interface Display Identification

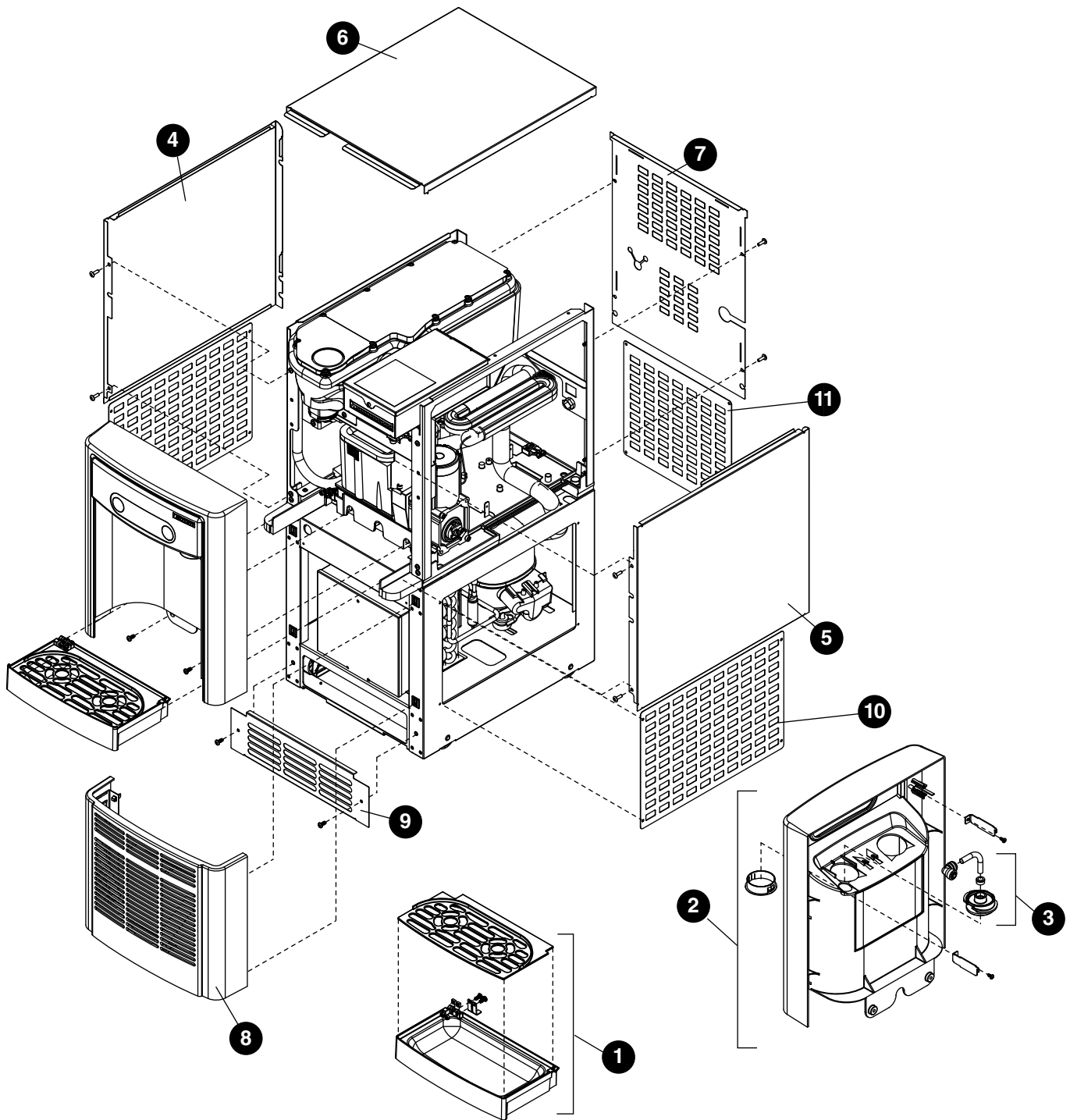
Operation Display	Condition	Procedure
	Normal operation	—
	Cleaning Mode	Press and release maintenance/clean switch to clean the user interface without dispensing ice or water (see <a href="#">Maintenance/Cleaning Mode on page 9</a> ).
	Drip tray full	Empty drip tray.
	Six-month periodic maintenance required	Follow Maintenance Mode procedure (below) and also see <a href="#">Cleaning and Sanitizing Procedure on page 11</a> .
	Maintenance Mode	Enter Maintenance Mode by pressing maintenance/clean switch until  displays. Complete the cleaning and sanitizing procedure shown on <a href="#">page 11</a> and change the filter, if so equipped. Exit Maintenance Mode by pressing and holding maintenance/clean switch until  no longer displays.
	8000-hour Service and maintenance check	Press and hold the reset button on the circuit board for one minute.
	High amps	Contact Follett technical service group at (877) 612-5086 or +1 (610) 252-7301. <b>Note:</b> For dispensers after serial number D45191, the phone and wrench will <i>not</i> be illuminated.
	Internal leak in dispenser	Locate leak and repair - Press reset on control board. Contact Follett if unit is leaking.
	Sleep mode	Press either dispense button to return to normal operation.



# Electrical Wiring Diagram



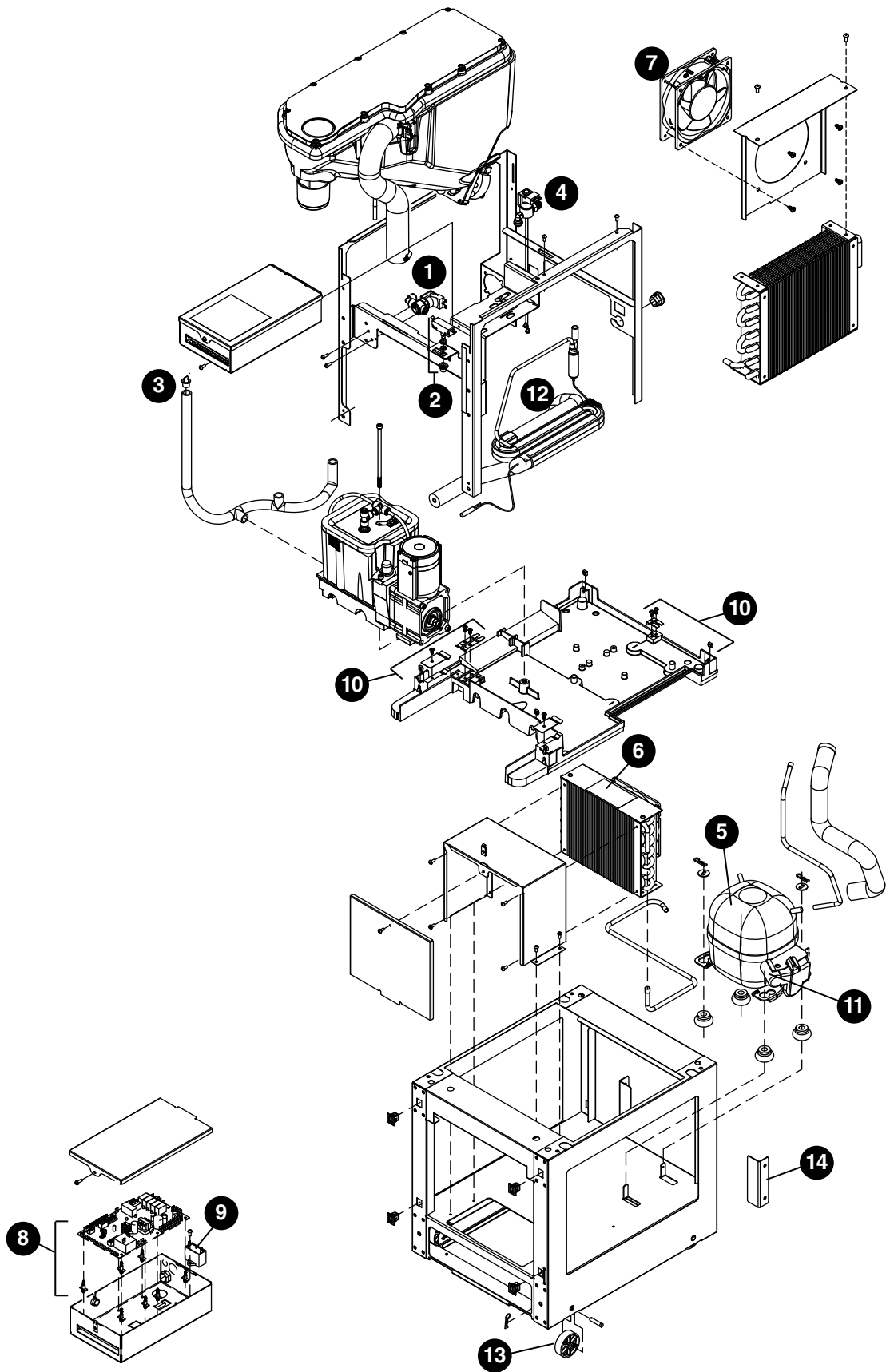
# Exterior



## Exterior

Reference #	Description	Part #
1	Drain, Tray Assy	00957613
2	Panel, Front Assy - Includes Water Nozzle and Plug	00957621
3	Chute, Water (water option)	00957688
4	Panel, Top Left	00947010
5	Panel, Top Right	00947028
6	Panel, Top	00957654
7	Panel, Rear	00957662
8	Panel, Lower, 7UC100A Height: 12.0" (304.8 mm)	00932855
	Panel, Lower, 7UD100A Height: 10.0" (254 mm)	00932863
9	Panel, Intake	00947119
Not Shown	Cord, 115 VAC	00958058
Not Shown	Packaging for Returns, Dispenser	00957993
10	Panel, Bottom Left/Right, 7UC100A	00967331
	Panel, Bottom Left/Right, 7UD100A	00967356
11	Panel, Bottom Rear, 7UC100A	00967349
	Panel, Bottom Rear, 7UC100A	00967364
Not Shown	Fitting, Elbow - 1/4" FPT x 1/4" Tube	00974261
Not Shown	Fitting, Elbow - 1/4" FPT x 3/8" Tube	00990796
Not Shown	Drip Tray Drain Kit	00956375

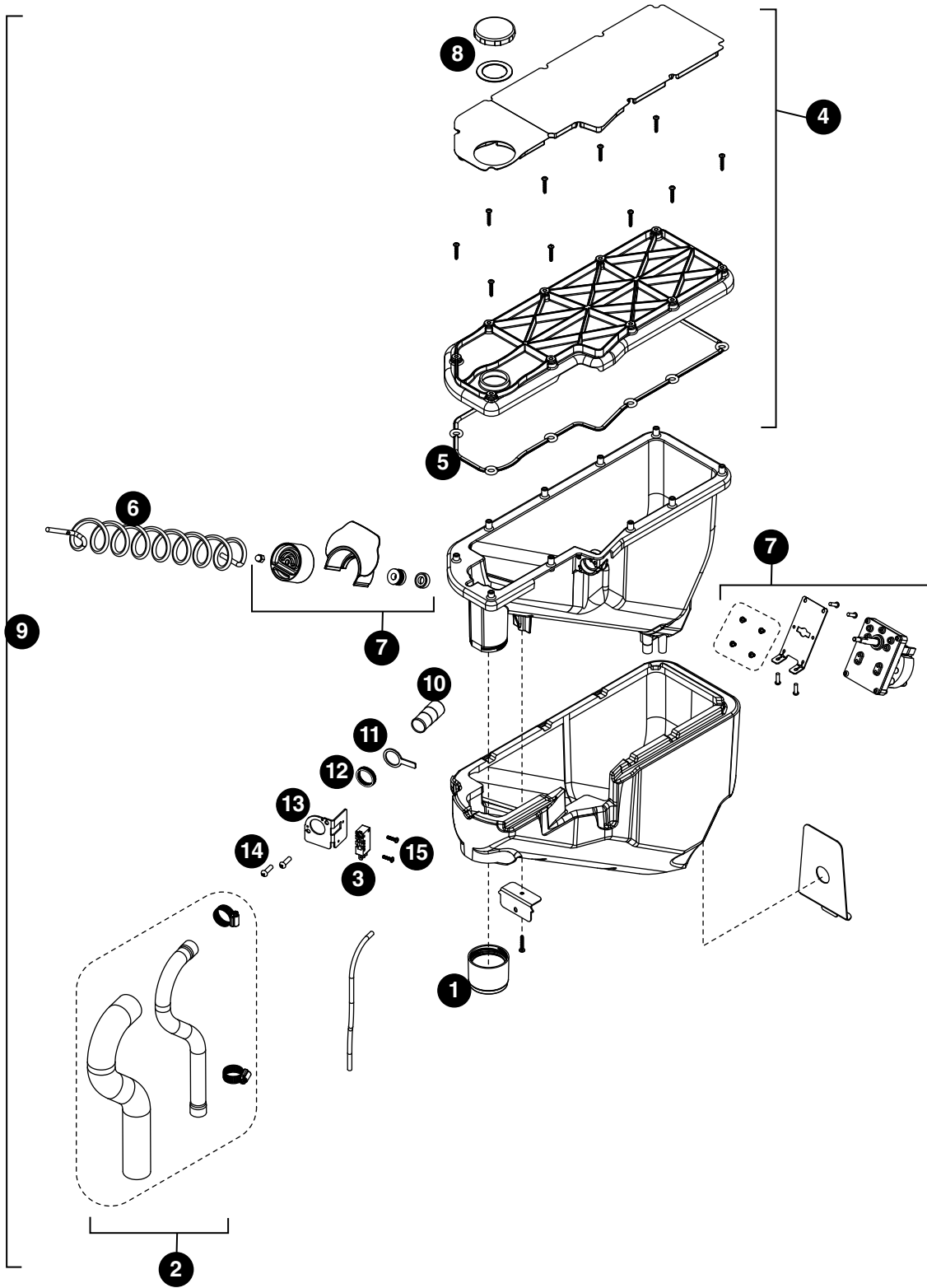
# Interior



**Interior**

<b>Reference #</b>	<b>Description</b>	<b>Part #</b>
1	Valve, Dispense Solenoid (water option)	00957704
2	Switch, Cleaning	00957712
3	Drain/Feed Tube with Cap	00957720
4	Valve, Failsafe Solenoid	00957738
5	Compressor with Mounting Hardware	01157296
6	Condenser	00958017
7	Condenser Fan, Cord and Hardware	01157288
8	Control Board with Stand-offs	00958033
9	Capacitor, Gearmotor	00958041
10	Sensor, Retainer Hardware Kit	00958066
11	Relay and Overload	01157387
12	Heat Exchanger, Kit	01233998
13	Roller Kit, Set of 4	00924753
14	Bracket, Stop	00961292

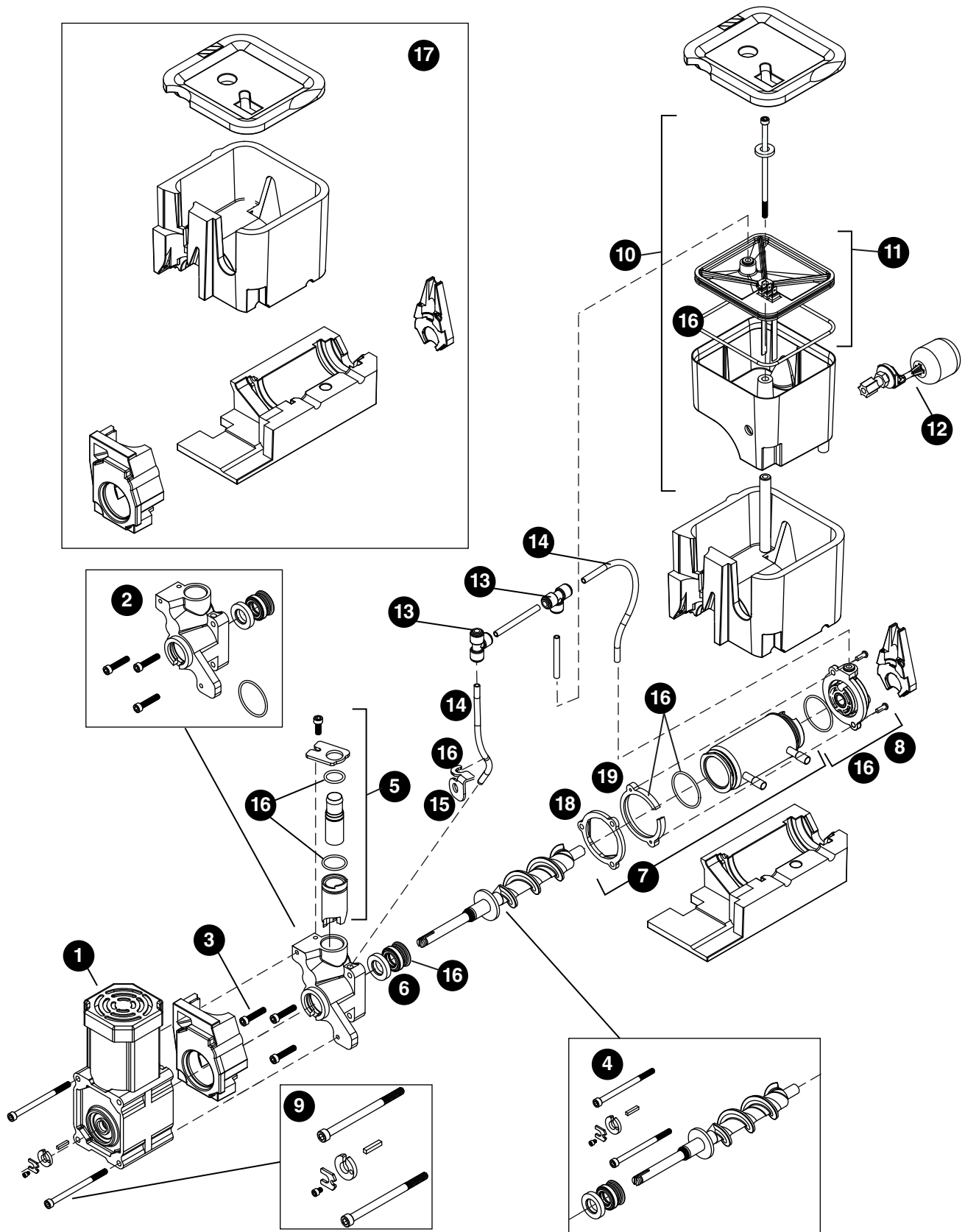
# 7 Series Bin Assembly



## 7 Series Bin Assembly

Reference #	Description	Part #
1	Ice Chute, Inside Thread	01238906
2	Ice Transport Tubing with Insulation	00957746
3	Switch, Shuttle	00957753
4	Lid, Bin Assy	01233808
5	Lid, Gasket, 7 Series	01233824
6	Auger, Dispense	00957795
7	Assembly, Motor Dispense	01233857
8	Cap and gasket	01233816
9	Bin assembly, 7 Series (does not include ice transport tube and insulation)	01233832
10	Coupling, transport tube	00998278
11	Flag, shuttle	00998286
12	Spring, wave	00998302
13	Bracket, shuttle support (Before serial number K46457)	00998260
13	Bracket, shuttle support (After serial number K46456)	00998336
14	Screws (2), self-tapping, #10 x 5/8	00998328
15	Screws (2), M3 x 12 Phillips pan head	00998294

# Evaporator Assembly





## Evaporator Assembly

Reference #	Description	Part #
1	Gearmotor Assy	00957811
2	Main Housing with Front Seal, Screws, (includes vent tube, retainer and o-ring)	00957829
3	Screws, Main Housing	00957837
4	Auger with front seal	00957845
5	Ice Compression Nozzle Assy	00957852
6	Front Seal and O-Ring	00957860
7	Evaporator Assembly	01157353
8	Housing, Bushing	00957886
9	Hardware kit, Gearmotor (For serial numbers E01087 and above)	01048628
9	Hardware kit, Gearmotor (For serial numbers below E01087)	00957894
10	Reservoir and Float Complete Assy (does not include insulation)	00957902
11	Lid, Reservoir with Insulation and O-Ring (does not include bolt or insulation)	00957910
12	Float Valve	00957928
13	"T" Fitting - 1/4"	502923
14	Tubing - 1/4" (sold in 12" increments)	502079
15	Vent Tube Retainer (includes vent tube)	01278779
16	Seal kit (includes front auger seal, reservoir lid o-ring, compression nozzle o-rings, end bushing cap with o-ring and (2) screws, rear flange jacket, vent tube retainer, and 1 ft of 1/4" tubing)	01348093
17	Insulation Kit (5 pieces)	01442557
18	Front Flange Jacket	00947721
19	Rear Flange Jacket	00947739

## Miscellaneous

Reference #	Description	Part #
Not Shown	Water filter cartridge, 5 micron	00968107
Not Shown	Cleaning and sanitizing kit, single use	00979856
Not Shown	SafeClean Plus liquid, case of 6	01149954
Not Shown	SafeClean Plus liquid, case of 24	01149962
Not Shown	IMS III sanitizer concentrate, 16 oz	00979674





## Warranty Registration and Equipment Evaluation

Thank you for purchasing Follett® equipment. Our goal is to deliver high value products and services that earn your complete satisfaction by delivering high-value products and services backed by outstanding customer and technical support.

Please review the installation instructions thoroughly. It is important that the installation be performed to factory specifications so your equipment operates at its maximum efficiency.

Follett LLC will not be liable for any consequential damages, expenses, connecting or disconnecting charges, or any losses resulting from a defect of the machine. For full warranty details, visit our website [www.follettice.com/productwarranties](http://www.follettice.com/productwarranties).

Registering your equipments helps Follett track your equipment's service history should you need to contact us for technical support, and your feedback helps us improve our products and services. Please visit [www.follettice.com/support](http://www.follettice.com/support) to complete the Warranty Registration form.

Should you have any questions, please contact Follett's technical support group at (877) 612-5086 or (610) 252-7301 and we will be happy to assist you.

SafeCLEAN is a trademark of Follett LLC.  
Follett is a registered trademark of Follett LLC, registered in US.