

## Installation Guide

Please visit <https://www.follettice.com/technicaldocuments>  
for the Operation and Service manual for your unit

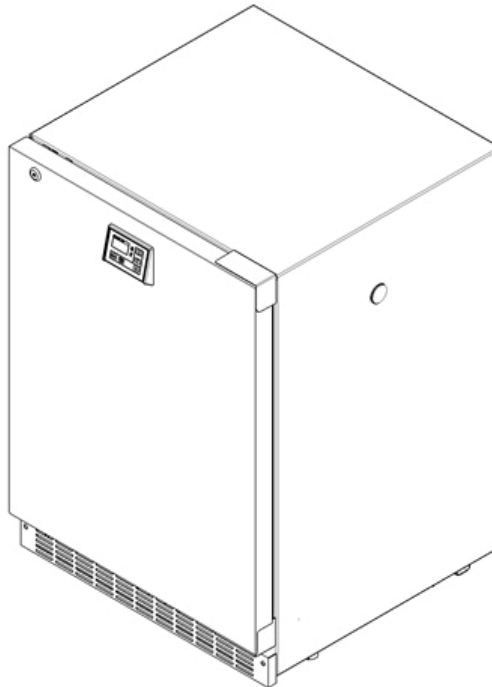

## Welcome to Follett

Follett equipment enjoys a well-deserved reputation for excellent performance, long-term reliability and outstanding after-the-sale support. To ensure that this equipment delivers that same degree of service, review this guide carefully before you begin your installation.

Should you need technical help, please call our Technical Service group at (877) 612-5086 or (610) 252-7301.

Please have your model number, serial number and complete and detailed explanation of the problem when contacting Technical Service.

## Getting Started

After uncrating and removing all packing material, inspect the equipment for concealed shipping damage. All freight is to be inspected upon delivery. If visible signs of damage exist, please refuse delivery or sign your delivery receipt "damaged." Follett Customer Service must be notified within 48 hours. Wherever possible, please include detailed photos of the damage with the original packaging so that we may start the freight claim process.

## Preliminary Information

### Caution Flammable Refrigerant



**Caution: Risk of fire.**

#### **DANGER**

- Risk of fire or explosion. Flammable refrigerant used.

**Before attempting to install or service this product, all safety precautions must be followed.**

**CAUTION!** – Risk of fire or explosion. Dispose of properly in accordance with federal or local regulations. Flammable refrigerant used.

**CAUTION!** – Risk of fire or explosion due to puncture of refrigerant tubing; follow handling instructions carefully. Flammable refrigerant used.

**CAUTION!** – Handling, moving, and operating the refrigerator to avoid either damaging the refrigerant tubing or increasing the risk of a leak.

#### **CAUTION!**

- If the equipment is not transported vertically, a period of at least 24 hours must be allowed before starting.

The equipment must be transported and handled exclusively in upright position. This is required to avoid contamination of the refrigerant with compressor oil. Contamination could result in valve and heat exchanger coil failure, problems starting the electric motor, or the risk of gas leak. The manufacturer is not responsible for any problems due to transport executed in conditions other than those specified.

The equipment must be handled using a fork lift truck or a pallet truck with suitable forks (fork length at least equal to 2/3 length of unit).

#### **WARNING!**

- Read this manual thoroughly before operating, installing or performing maintenance on the equipment. Failure to follow instructions in this manual can cause property damage, injury or death.
- The machine contains R600a, refrigerant. R600a (isobutane) is flammable.
- When servicing this equipment, be sure to lock the circuit breaker, and display an in-service notice.
- This equipment contains high-voltage electricity and refrigerant charge. Installation and repairs are to be performed by properly trained technicians aware of the dangers of dealing with high voltage electricity and refrigerant under pressure. The technician must also be certified in proper refrigerant handling and servicing procedures. All lockout and tag out procedures must be followed when working on this equipment.
- Repair on R600a systems must always be done in a well-ventilated area.
- Because R600a is highly flammable, a combustible gas leak detector is required when servicing R600a systems.
- Only use parts recommended or provided by the manufacturer.
- Do not tilt unit further than 30° off vertical during uncrating or installation.
- If the supply cord is damaged, it must be replaced by the manufacturer, its service agent or similarly qualified persons in order to avoid a hazard.
- This appliance is designed for commercial use.
- To reduce risk of shock, disconnect power before servicing.

## General Information

- To avoid temperature rise in the cabinet and/or contents, care should be taken to ensure that the door is opened only for brief periods.
- Ensure that the intake and exhaust vents are not blocked. Adequate space should be provided between the items inside the unit to allow air circulation. Too much stock will result in temperature of about –2 C around the exhaust vent when the set temperature is 2 C. It is recommended to set the temperature to 4 C or 5 C when a large quantity of articles that should not be frozen is stored.
- In the refrigerator compartment, put stored items on the shelves and do not let them contact the wall.
- Fix the shelves securely. Place items on the shelves and leave a space between the wall of the cabinet and the contents to allow air circulation. Do not place items on the floor of the chamber.

- The unit shall not be exposed to direct sunlight and shall not be near a heat source such as a heater, stove, or other heat dissipating equipment (sterilizer, autoclave, etc.).
- Do not clean the unit with scrubbing brushes, acid, thinner, solvents powdered soap, cleanser or hot water. These agents can scratch the paint or cause it to peel. Plastic and rubber parts can be easily damaged by these materials. Especially never use any volatile solvent to clean the plastic or rubber parts. When a neutral dishwashing detergent is used to clean the unit, wipe it up thoroughly with a cloth soaked in clean water.
- The unit is supplied with two keys.

 **CAUTION!**

- *Equipment must be wired according to local and national electrical codes.*
- *Always disconnect power before servicing.*

## Specifications

Product name	Laboratory Refrigerator
Model number	REFNAT5-SD (solid door)/REFNAT5-GD (glass door)
External dimensions	34.16" H x 23.84" W x 23.66" D (86.7 H cm x 60.6 W cm x 60.0 D cm)
Internal dimensions	25.59" H x 19.94" W x 17.09" D (65.0 H cm x 50.7 W cm x 43.4 D cm)
Effective capacity	5.01 ft <sup>3</sup> (142 liters)
Exterior	White PCM galvanized steel, polyester resin baked finish
Interior	HFO vacuum formed plastic
Door	Electro galvanized steel
Insulation	HFO foamed-in place
Shelve	Coated steel wire (3 pieces), Size: 19.19" W x 14.75" D (48.7 W cm x 37.5 D cm), Weight: 2.2 lb (1 kg). Maximum load capacity (for each shelf): 33 lb (15 kg)
Access port	Inner diameter 1.19" (30 mm), 1 port on the right side
Cooling method	Forced air circulation
Compressor	Reciprocal type, output; 40 W
Evaporator	Flat fin type
Condenser	Wire type
Refrigerant	R600a; 52 g (0.114 lb)
Defrosting	Automatic heater defrost
Defrost heater	115 V/106 W (125Ω ±0.7Ω @ 25 C)
Temperature controller	Microprocessor control system
Temperature display	Digital display
Alarm and safety	High temperature alarm, low temperature alarm, defrost sensor abnormality, power failure remote alarm, door alarm, key lock, thermal sensor abnormality
Memory backup	Nonvolatile memory
Weight	Solid door: 100 lb (45 kg), Glass door: 106 lb (48 kg)
Accessories	1 set of keys
Temperature control range	5 C ± 3 C
Rated voltage	115 V AC
Rated frequency	60 Hz
Power consumption	106 kWh per year
Climatic class	7

Note: Design or specifications will be subject to change without notice.

## Dimensions

Width (up to hinge cover)	23.84" (60.6 cm)
Height (up to hinge cover)	34.16" (86.7 cm)
Depth (up to Solid Door)	23.66" (60.0 cm)
Door Height	SD: 30.63" (77.7 cm), GD: 30.75" (78.1 cm)

## Electrical Specifications

- 115 V, 60 Hz, 1 phase (Main supply voltage fluctuations not to exceed  $\pm 10\%$  of the nominal voltage (120 V))

## Refrigeration Specifications

Refrigerant	Charge Size
R600a	52 g (0.114 lb).

## Refrigeration System

The refrigeration system is designed to give many years of trouble-free service. Except for routine cleaning of the air-cooled condenser and related parts, the refrigeration system requires no service or maintenance. The system uses a capillary tube and is critically charged. The connection of refrigeration service hoses to the fittings will almost invariably result in a significant change in the system charge. This change can adversely affect the performance of your refrigerator. Therefore, Follett recommends that if hoses are ever connected to the refrigeration system for service, the refrigerant should be recovered, the system evacuated, and recharged by weighing in the correct refrigerant charge.

*Use of a combustible gas meter for detecting HC refrigerants needs to be within 1 meter of working area. Service technician should also have a safety placard for the work area stating "Flammable Gas no smoking or open flames".*

## Installation Specifications

- Altitude up to 6561.68 ft (2000 m)
- Ambient temperature 68 F to 75 F (20 C to 24 C) for maximum efficiency
- Maximum relative humidity 75% for temperature up to 24 C decreasing linearly to 50%
- Ambient temperature must not exceed 100 F (39 C)
- The front louvered panel must be kept free of any cabinet trim or obstructions to ensure proper ventilation of the refrigeration system - allow at least 12" (30.48 cm) of clearance in front of panel



### **CAUTION!**

- *Equipment must be wired according to local and national electrical codes.*
- *Always disconnect power before servicing refrigerator.*

## Installation

1. Remove the packaging materials and tape. Open the doors and ventilate the unit. If the outside panels are dirty, clean them with a diluted neutral dishwashing detergent. (Undiluted detergent can damage the plastic components. For the dilution, refer to the instruction of the detergent.) After cleaning with the diluted detergent, always wipe it off with a wet cloth, then wipe the panels with a dry cloth.
2. Door handle installation: Remove the two plugs from the door where you will attach the door handle. Apply door handle, plastic washer and screw and fasten the screw. For floor-level installation, the handle should be mounted at the higher location. For stacking above another compatible unit, the handle should be mounted at the lower location.
3. Access Port: If a temperature sensor is to be placed inside the cabinet, the cable can be led through the access port on the right side of the cabinet. After using the port, a rubber cap and insulation should be reinstalled to seal the access port. Make a cut on the rubber cap and pass the sensor wire through it. Failure to do this can affect the temperature uniformity inside the cabinet and lead to condensation on the outside of the access port.
4. Ensure unit is level, adjust legs as needed to level refrigerator in both directions.
5. Connect the unit to dedicated power supply. Do not put any product in the unit at this time.
6. Clean the refrigerator before putting into service.

## Cleaning

Clean the unit once a month. Removal of dust and other particulates from air intake areas and the condenser is important for proper operation. Environments with large amounts of dust may require more frequent cleaning.

### WARNING

Always disconnect the power supply to the unit prior to any repair or maintenance of the unit in order to prevent electric shock or injury.

- Never pour water onto or into the unit. Doing so can damage the electrical insulation and may cause electric shock or short circuit.
- The compressor and other mechanical part are completely sealed. This unit requires absolutely no lubrication.

**Note:** Do not remove top wire shelf. The purpose of this component is to keep the top area free of material and assure the air flows through the entire unit uniformly.

1. Remove the wires shelves. For removal of side wire barriers, you must begin from top to bottom, in order to have clearance while removing the components. Remove the side wire barrier by lifting up and compressing top towards inside of component. Finally, slide down to remove.
2. Use a dry cloth to wipe off small amounts of dirt on the outside and inside of the unit and all accessories. If the outside panels are dirty, clean them with a diluted neutral dishwashing detergent. (Undiluted detergent can damage the plastic components. For the dilution, refer to the instruction of the detergent.) After the cleaning with the diluted detergent, always wipe it off with a wet cloth. Then wipe off the cabinet or accessories with a dry cloth.
3. Open the refrigerator door. Using a Philips screwdriver, remove the two screws securing the base grille. Set aside the base grille.
4. Use a vacuum cleaner with brush attachment to clean condenser regularly (as often as every other month).
5. Reinstall the base grille.

## Cooling System Operation and Loading

Follett Edge Series refrigerators have a programmable set point range of 2 C to 8 C in 0.1 degree increments, but are preset with a temperature set point of 5 C. The cooling system, as well as the display temperature, operate on the cabinet air temperature.

Once the refrigerator has been powered on and maintaining your desired temperature, slowly introduce product into the cabinet in small batches and allow the temperature to recover. This procedure should be performed until the cabinet is full.

The cooling system is designed to pull to set point range within 30 minutes of initial power up.

The cooling system will recover in roughly 15 minutes of a 3 minute door opening. Avoid frequent door openings and introduction of large amounts of thermal mass at one time.

## Defrost

Follett Edge Series refrigerators have an automatic defrost cycle designed to keep the evaporator coil frost free. Refrigerators do not require manual defrosting.

For every 18 hours of cumulative compressor run time, the controller will initiate a defrost cycle. During this time the compressor, evaporator fan, and condenser fan power down while the defrost heater is energized to remove accumulated frost from the coil. Upon termination of the defrost cycle, the cooling system will again become operational. The defrost system is designed to keep the cabinet within 2 C to 8 C during defrost.

## Controller Operating Instructions

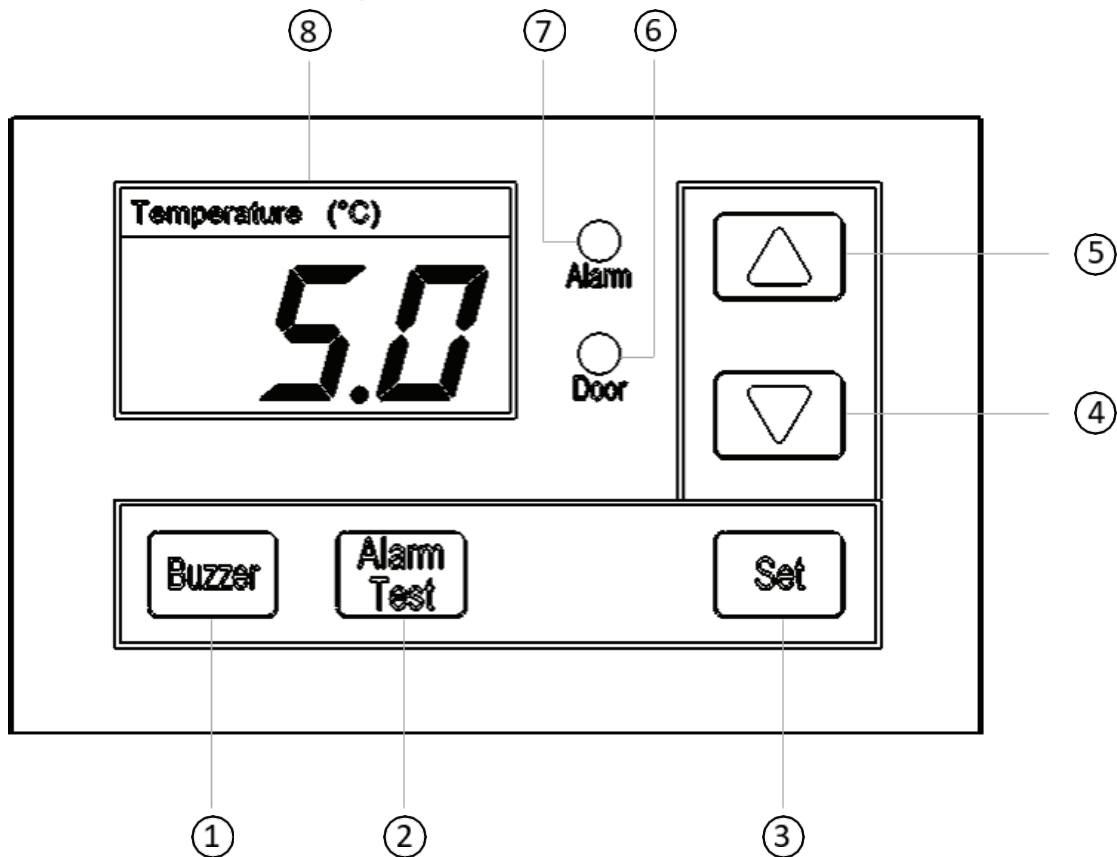

1. **Alarm buzzer stop key (BUZZER):** Press this key to silence the buzzer in the event that the alarm operates and the buzzer sounds.
2. **Alarm test key (ALARM TEST):** Buzzer will sound.
3. **Set key (SET):** Pressing this key activates temperature set mode. By pressing the key again after setting, the set value is accepted.
4. **Down Arrow (▼):** Pressing this down arrow key in the setting mode causes the numerical value to go down in 0.1 C increments. A long press of this key will enter offset mode. Offset mode is used to calibrate the temperature display.
5. **Up Arrow (▲):** Pressing this up arrow key in the setting mode causes the numerical value to go up in 0.1 C increments. A long press of this key will enter or exit the key lock mode.
6. **Door check (DOOR):** This is lit when the door is open.
7. **Alarm (ALARM):** This is lit during alarm condition.
8. **Temperature display:** This indicator shows the chamber temperature, set temperature, or error code

## Control Panel Functionality Check

The first time the unit is powered on, follow the operation below to ensure control panel functionality.

### Manual check of Control Panel

	Operation	Key operated	Control panel description
1	Connect to the power source.	-----	Five seconds after turning on the unit, the temperature inside the unit should appear on temperature display (LED Screen).
2	Press "Alarm Test" key.	ALARM TEST	Two seconds after pressing the button, the buzzer should sound every 1 second. Let the buzzer sound at least 3 times.
3	Press "Alarm Test" key.	ALARM TEST	Within 2 seconds of pressing the button, the buzzer should stop. (The buzzer should stop sounding after two second of pressing the button).
4	Press "SET" key.	SET	Within 2 seconds of pressing the button, you will hear a beep once. The display will show "5.0" on LED Screen and it will start blinking.
5	Press ▼ key.	▼	Within 2 seconds of pressing the button, you will hear a beep once. The display will show "4.9" on LED Screen and it will start blinking.
6	Press ▼ key two times.	▼	Within 2 seconds of pressing the button, you will hear a beep once. The display will show "4.7" on LED Screen and it will start blinking.
7	Press ▲ key three times.	▲	Within 2 seconds of pressing the button, you will hear a beep once. The display will show "5.0" on LED Screen and it will start blinking.
9	Open the door	-----	Two seconds after opening the door, the door check lamp will turn red.
10	Close the door	-----	Two seconds after closing the door, the door check lamp will turn off.
11	Open the door	-----	Two seconds after opening the door, the door check lamp will turn red.
12	Keep the door open	-----	After 120 seconds, the alarm LED will turn red and will start beeping every second. Let the unit beep at least 3 times.
13	Close the door	-----	Two seconds after closing the door, the door check LED will turn off.



## Operating Instructions

The table below shows the basic operation method. Perform key operation in the sequence indicated in the table. The example in the table assumes that the refrigerator temperature is 6.0 C.

**Note:** The unit is set at the factory at 5.0 C.

### Basic Operation Procedure (Example of setting the refrigerator to 4.0 C)

	Operation	Key operated	Display after the key operation
1	Connect to the power source.	-----	The current refrigerator temperature is displayed after 5 seconds of connecting the unit to the power source. When refrigerator temperature is higher than 25 C, HI is displayed and LO is displayed when lower than -10 C.
2	Press SET key.	SET	The digits of the temperature display flash.
3	Set to 4 by using the down arrow key.	▼	Pressing and releasing the down arrow key shifts down the set point by 0.1 C increments.
4	Press and release SET key.	SET	The value (4.0) is stored in memory and the current refrigerator temperature is displayed.

**Note:** If no key has been pressed for 90 seconds in the temperature set mode, the display mode returns automatically to the temperature display mode. In this case, the chamber temperature setting is not changed. The refrigerator temperature can be set in the range between 2.0 C and 8.0 C. The guaranteed temperature with no load at an ambient temperature of 22 C is 2 C to 8 C.

## Calibration Procedure

If the displayed temperature differs from the temperature provided from a NIST-traceable thermometer placed in the center of the chamber, the display temperature can be adjusted to match.

As an example, the table below shows the procedure where displayed temperature is 4.5 C, and the NIST probe temperature is 5.2 C. Use the Offset Setup Procedure to match the display temperature to the NIST probe temperature.

### Offset Setup Procedure

	Operation	Key operated	Display after the key operated
			The current refrigerator temperature is displayed (4.5).
1	Press and hold the down arrow key more than 5 seconds.	▼	The digits of the temperature display flash.
2	Set to 5.2 by using Up arrow key.	▲	Pressing the key shifts up the figure by 0.1 C. Repeat until flashing digit turns to 0.7.
3	Press the set key.	SET	The current adjusted temperature (offset by +0.2 degrees) is displayed (5.2).

### Key Lock Operation

This unit incorporates a key lock feature that can inhibit tampering using the keys on the control panel. The key lock is set to OFF at the factory.

Display	Mode	Function
LOC	Key lock ON	Temperature change disabled

Key lock setup procedure (Example: Key lock OFF ⇌ Key lock ON)

	Operation	Key operated	Display after the key operated
			The current refrigerator temperature is displayed.
1	Press and hold the up arrow key for about 5 seconds.	▲	Display alternates between LOC and actual temperature

**Note:** Key lock can be set any time when the current refrigerator temperature is displayed.

## Alarms And Safety Functions

This unit has alarm and safety functions, and also a self-diagnostic function.

### Alarms and safety functions

Kind of Alarm or Safety	Situation	Indication	Buzzer	Safety Operation
High temperature alarm	If the chamber temperature exceeds the set temperature more than 3 C.	Alarm lamp is lit.	Intermittent tone after a delay of 15 minutes.	-----
Low temperature alarm	If the chamber temperature is lower 3 C than the set temperature.	Alarm lamp is lit.	Intermittent tone after a delay of 15 minutes.	-----
Power failure alarm	In the event of a power failure or disconnection of power supply plug from the outlet.	Display shuts off.	-----	-----
Door alarm	When door remains open for more than 2 minutes.	Alarm lamp lights after two minute delay.	Intermittent tone after a delay of 2 minutes.	-----
Auto return	If a key operation is not performed for about 90 seconds in each setting mode.	Chamber temperature is displayed.	-----	Setting mode is canceled.
Key lock	When the key lock is ON.	Alternate LOC and actual temperature.	-----	Key input is disabled.
Thermal sensor abnormality	If the thermal sensor goes open (E10) or short circuit (E1S).	Either E10 or E1S is displayed.	-----	
Defrost sensor abnormality	If the defrost sensor goes open (E20) or short circuit (E2S).	Either E20 or E2S is displayed.	-----	If defrost is taking place, defrost will stop. If not, unit will not go into defrost.

## Troubleshooting

If the unit malfunctions, check the following potential causes before calling for service. In the case of inadequate refrigeration or freezing, transfer the stored items to another refrigerator before checking.

Refrigerator is too warm	Adjust temperature control. Make sure door is closed properly. Check if ambient temperature is too high. Check if door gasket is not damaged or has foreign substances preventing from closing the door adequately.
Refrigerator alarm is on	On start-up of the unit: The temperature in the unit does not match the set value on control panel. On use: Check if door has not been left opened for a long period of time.
Moisture collects on the outside	Frequent door openings in highly humid conditions can cause this. Reduce door openings and reduce time door is open. Make sure door seal is tight.
Refrigerator is noisy	Make sure cabinet is level, not touching a wall or other surface, and rests squarely on the floor on all four corners. Normal noises include refrigerant gurgling as it passes through tubes and the compressor clicking on and off.
There is an odor in the refrigerator	Check to ensure the items stored are not causing the odor. Clean interior.

# Wiring Diagram

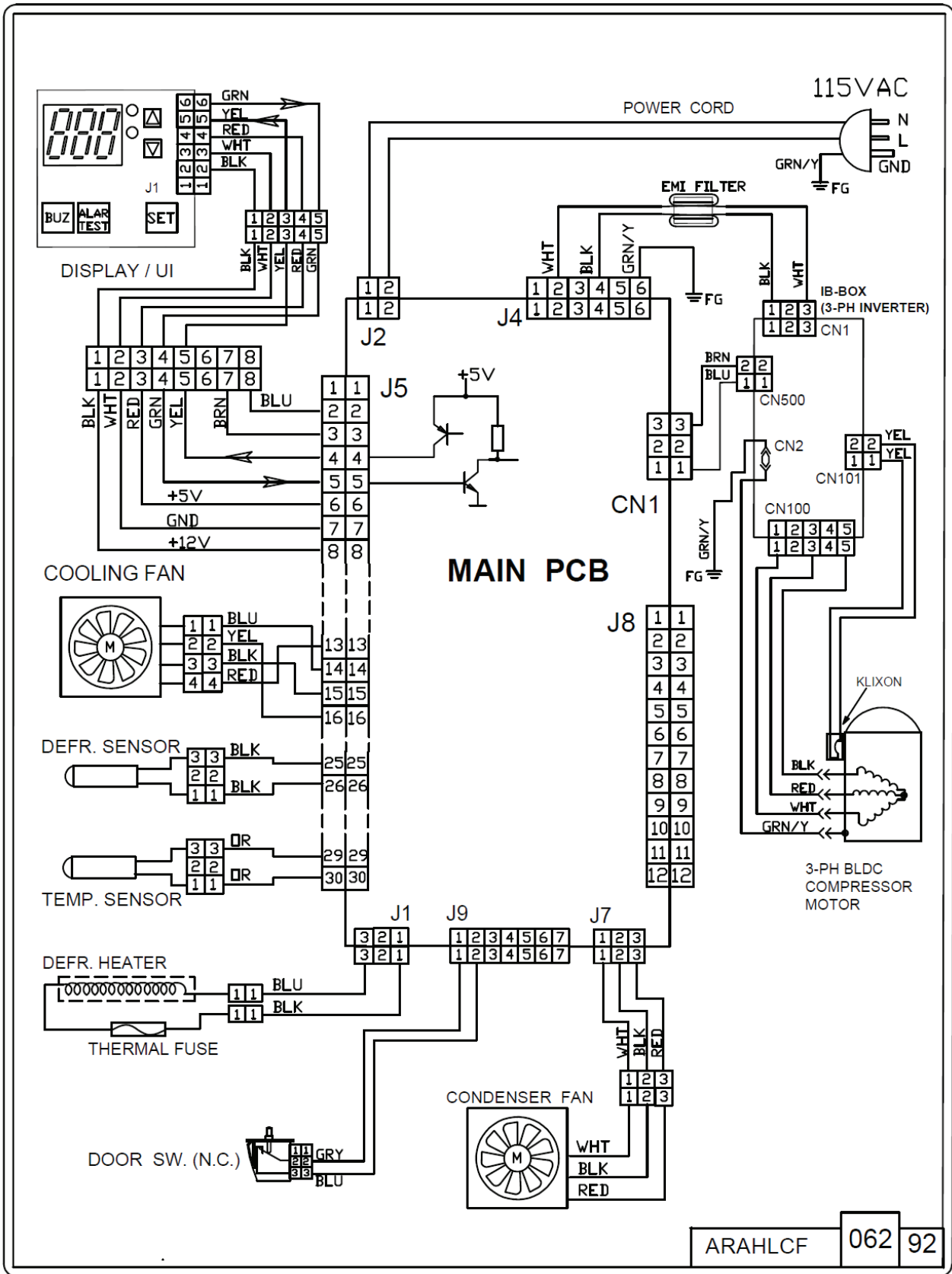

ARAHLCF 062 92

## Components

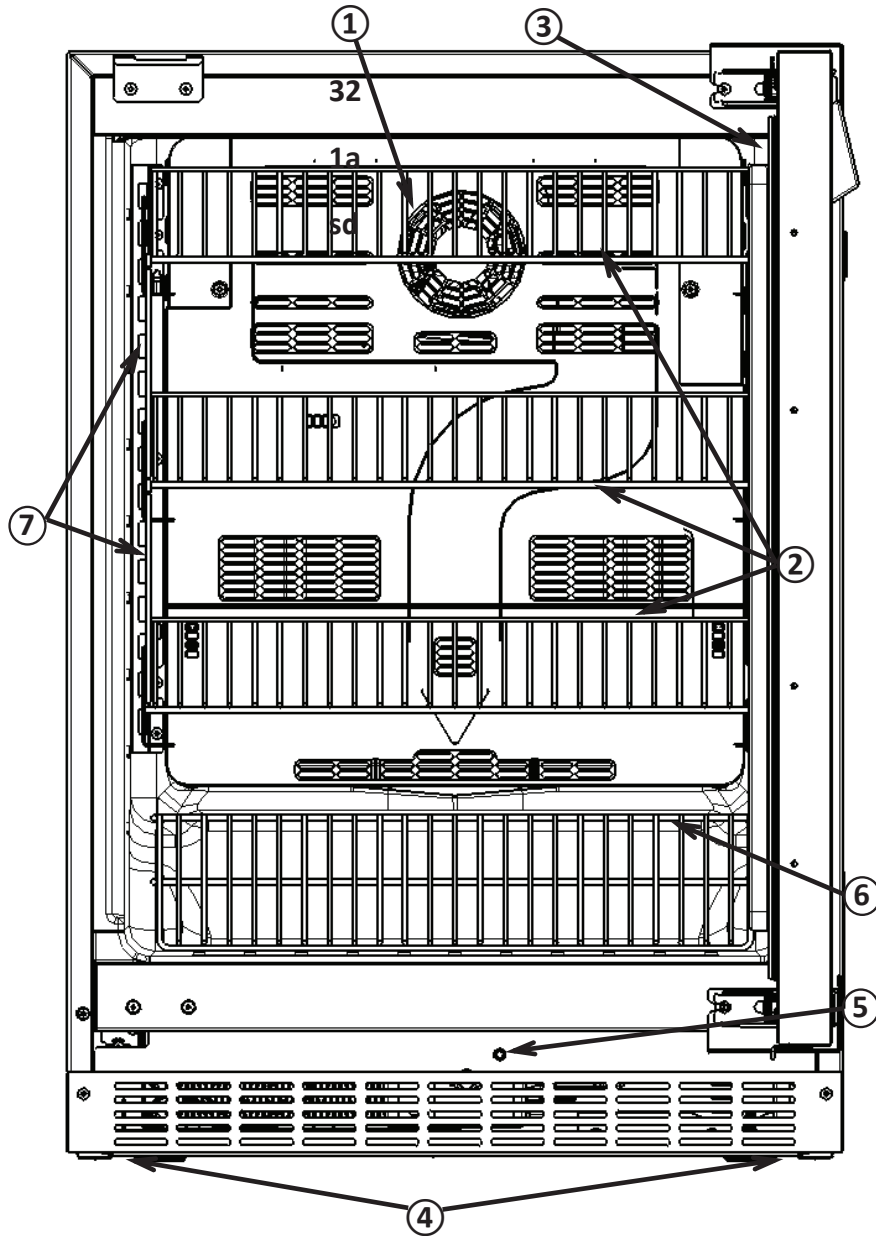

- 1. Circulation Fan:** Helps to keep a consistent temperature throughout entire chamber.
- 2. Powder coated wire shelves:** Space between shelves can be easily adjusted for maximum storing efficiency.
- 3. Magnetic door gasket:** Magnetic force ensures the door is sealed to provide optimum performance and temperature uniformity.
- 4. Adjustable legs:** Use these to level the refrigerator.
- 5. Door Open Sensor:** Signals alarm if door is left open.
- 6. Wire Basket:** Provides more usable space on bottom section of the unit. (Optional kit)
- 7. Powder coated side wire barrier:** Prevents misplacing of material inside the unit.

**PLEASE NOTE:** This unit is designed with physical barriers to prevent storage of product where it could be exposed to adverse temperature fluctuations or freezing temperatures (Item #7). Do not remove these barriers. To adjust wire shelves and side wire barrier, refer to section "Wire shelves and accessories". Furthermore, the specially designed shelves include bends in the rear to prevent product from touching the evaporator for the same reason. Ensure shelves are installed with the upward bend to the rear and facing upward.

## Warranty Registration and Equipment Evaluation

Thank you for purchasing Follett® equipment. We hope you find that our equipment meets or exceeds your expectations, as our goal is to deliver high value products and services that earn your complete satisfaction!

Please review the enclosed installation and operations manual. It is important that the installation be performed to factory specifications, so your equipment operates to its maximum efficiency.

Follett Products, LLC will not be liable for any consequential damages, expenses, connecting or disconnecting charges or any losses resulting from a defect of the machine.

For full warranty details, visit our website [www.follettice.com/productwarranties](http://www.follettice.com/productwarranties).

Warranty registration and equipment evaluation is important to help us keep track of our equipment and to record the machine's performance. We request that you register Follett equipment warranties on our website [www.follettice.com/support](http://www.follettice.com/support) and choose Warranty Registration and Equipment Evaluation. It's simple to do; please take a moment to register today. There is also space on the form to provide us with comments and feedback. Please let us know about your experience so we can capture it for our continuous improvement efforts.

We pride ourselves on producing outstanding equipment and we work hard to back it up with outstanding customer and technical support. Please let us know what else we can do to assist you. We would be happy to answer your questions.

EDGE SERIES is a trademark of Follett Products, LLC.  
FOLLETT and FOLLETT HEALTHCARE are registered trademarks of Follett Products, LLC, registered in the US.



801 Church Lane • Easton, PA 18040, USA  
Toll free (877) 612-5086 • +1 (610) 252-7301  
[www.follettice.com/healthcare](http://www.follettice.com/healthcare)

01519719R00  
© Follett Products, LLC 6/22