

# Horizon Elite™ Ice Machine Models with RIDE® Technology Installation Instructions for Vision™

HCD/HMD/HCF/HMF1010RVS, HCD/HMD/HCF/HMF1410RVS  
HCD/HMD1010NVS, HCD/HMD1410NVS  
(See model number configurator on page 2 for details.)

Order parts online  
[www.follettice.com](http://www.follettice.com)

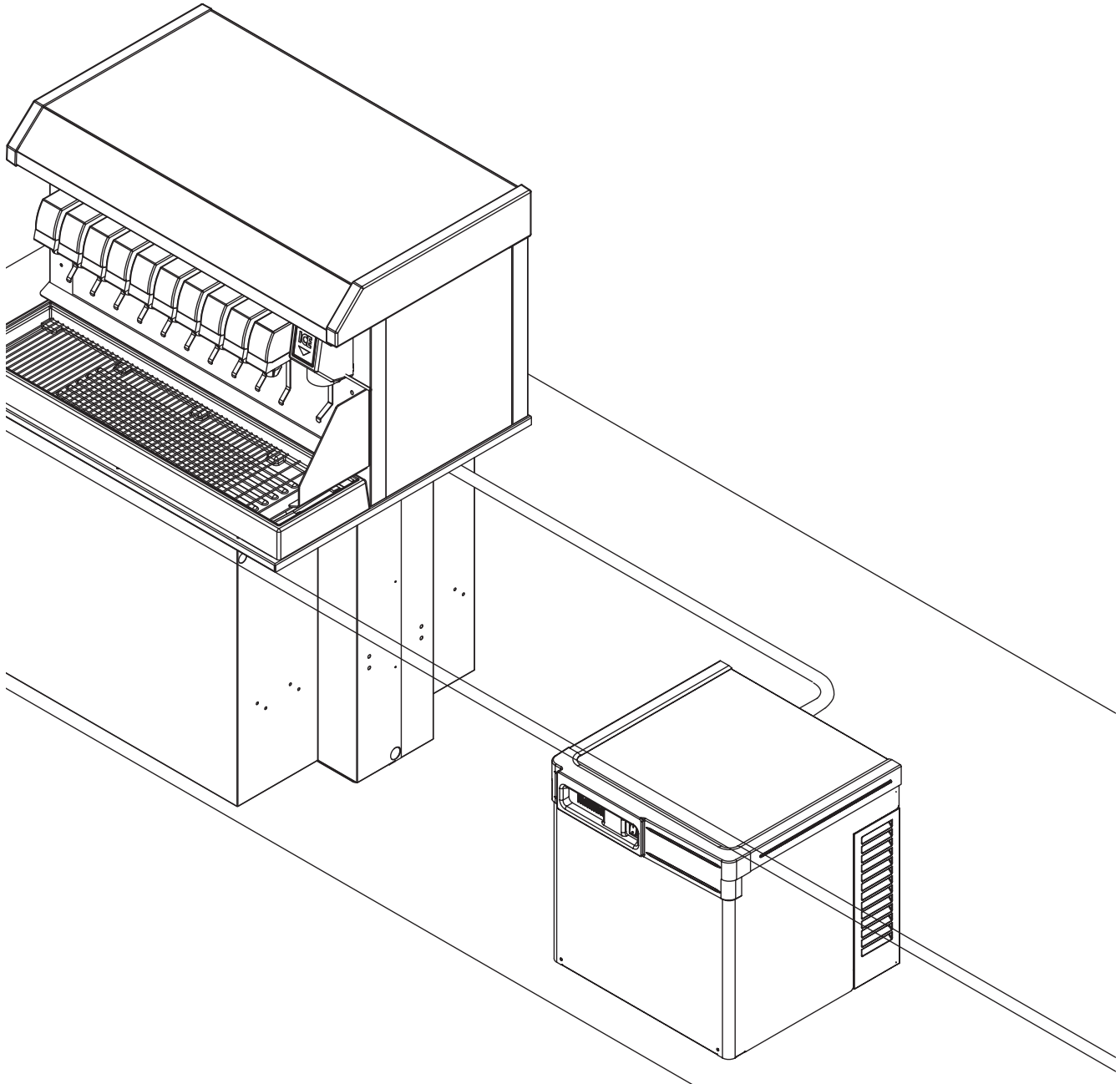
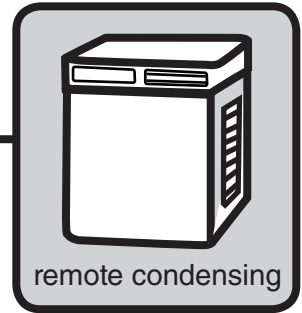

## Chewblet® Ice Machine Model Number Configurations

HC
D
1810
A
V
S

Icemaker	Voltage	Series	Condenser	Application	Configuration
MC Maestro™ Chewblet® (425 Series)	C 208-230/60/1 (icemaking head) <i>Self-contained only.</i>	425 up to 425 lbs (193 kg)	A Air-cooled, self-contained W Water-cooled, self-contained	V Vision™ H Harmony™	S RIDE™ (RIDE remote ice delivery equipment)
HC Horizon Chewblet (710, 1010, 1410, 1810, 2110 Series)	D 115/60/1 (icemaking head) <i>Self-contained and remote. If remote unit, high side is 208-230/60/1.</i>	710 up to 675 lbs (306 kg)	R Air-cooled, remote condensing unit N Air-cooled, no condensing unit for connection to parallel rack system	B Ice storage bin J Drop-in M Ice Manager diverter valve system P Cornelius Profile PR150	T Top-mount
HM Horizon Micro Chewblet	E 230/50/1 (icemaking head) <i>Self-contained only.</i> F 115/60/1 (icemaking head) <i>Remote only. High side is 208-230/60/3.</i>	1010 up to 1061 lbs (482 kg) 1410 up to 1466 lbs (665 kg) 1810 up to 1790 lbs (812 kg) 2110 up to 2039 lbs (925 kg)			

### ⚠ CAUTION!

- This appliance should be connected by a qualified person in accordance with applicable codes.
- If the supply cord is damaged, it must be replaced by the manufacturer, its service agent or similarly qualified persons in order to avoid a hazard.
- Connect to potable water supply only.
- This appliance can be used by children aged 8 years and above and persons with reduced physical, sensory, or mental capabilities, or lack of experience and knowledge if they have been given supervision or instruction concerning use of the appliance in a safe way and understand the hazards involved. Children should be supervised to ensure that they do not play with the appliance.
- This appliance is intended to be used for household and similar applications such as staff kitchen areas in shops, offices and other working environments; farm houses and by clients in hotels, motels and other residential type environments; bed and breakfast type environments; catering and similar non-retail applications.
- **WARNING!** To avoid a hazard due to instability of the appliance, it must be fixed in accordance with the instructions.

Read and complete the following 8 installation steps

1 **Unpack** \_\_\_\_\_



2 **Site preparation** \_\_\_\_\_



3 **Dispenser preparation** \_\_\_\_\_



4 **Louvered docking assembly** \_\_\_\_\_

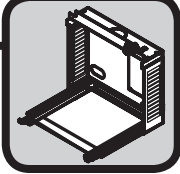

5 **Ice transport tube** \_\_\_\_\_



6 **External connection** \_\_\_\_\_



7 **Internal connection** \_\_\_\_\_



8 **Front cover** \_\_\_\_\_

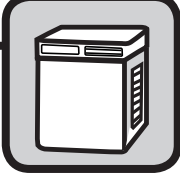

Carefully unpack and inspect the contents of your Follett ice machine.

Unpack

1



### 1.1 Unpack ice machine

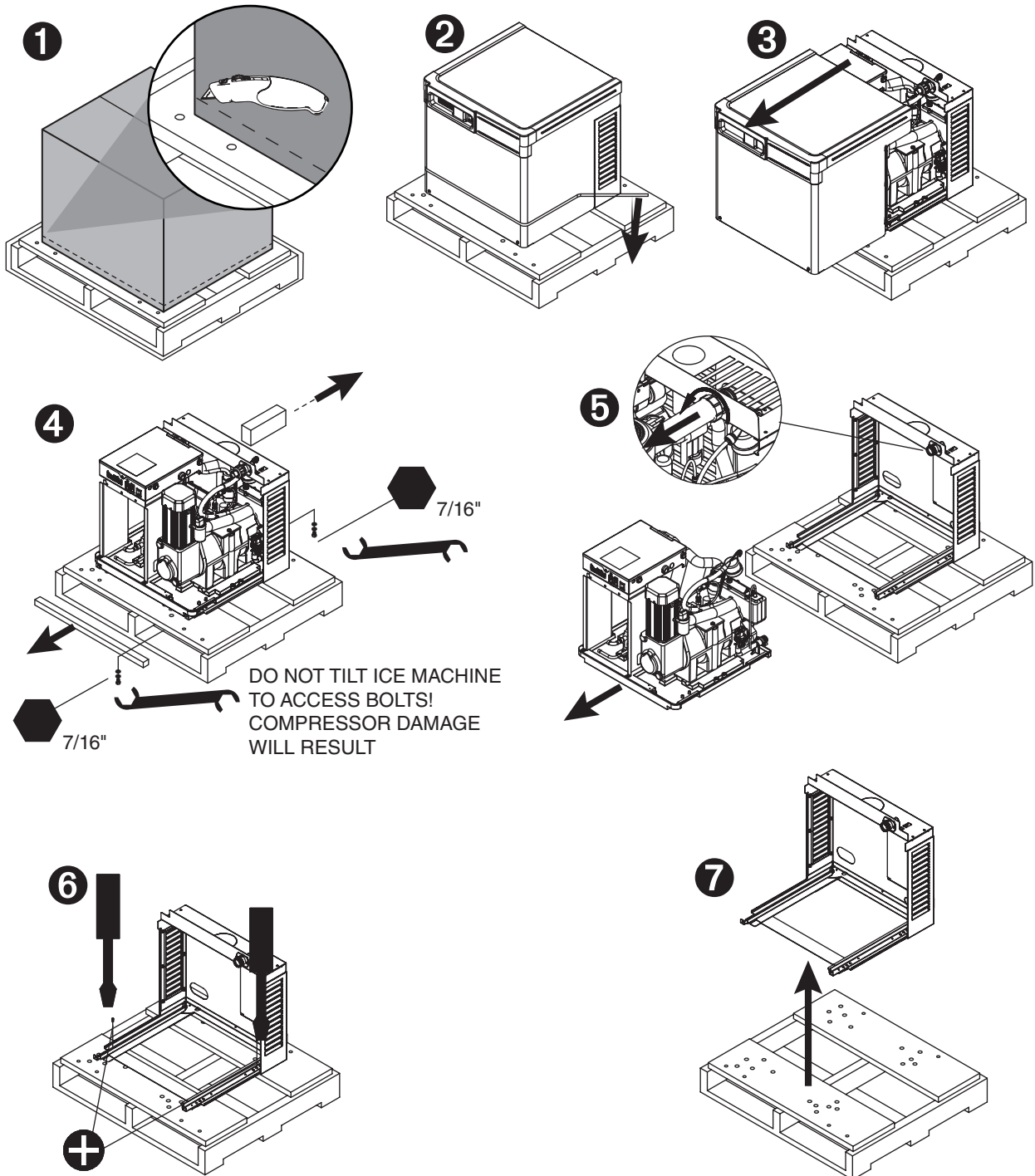

Prepare the installation site.

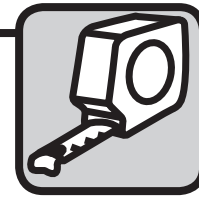

Provide drainage, water supply and electrical power to within 6 feet (2m) of ice machine in accordance with local and national codes. Outdoor installation of low side is not recommended and will void warranty.

2.1 Installation site requirements

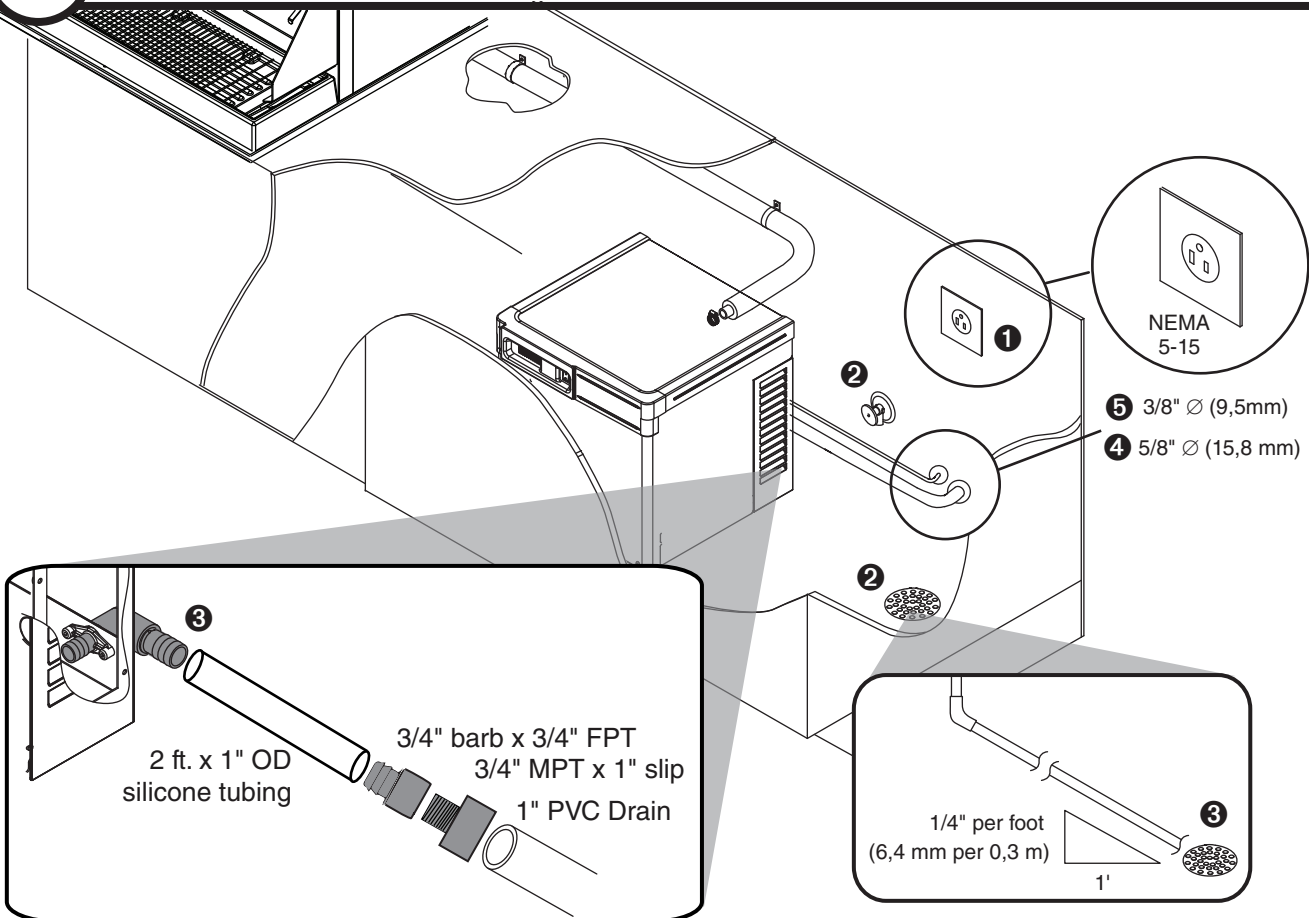

Electrical ①

- 120/60/1-5 amps

Potable water supply ② (3/8" push-in internal connection, 3/8" OD tubing required)

- 10-70 psi (69-483kpa)
- 45-90 F (7-32 C)
- Follett recommends the use of an in-line water filtration system (item# 00130286)
- This equipment is to be installed with adequate backflow protection to comply with applicable federal, state, and local codes

Drain ③ (3/4" BARB)

- Minimum 8" radius on silicone drain line. Drain line from the ice machine must have at least 1/4" per foot pitch (6,4mm/0,3m).

Refrigeration lines ④

- 5/8" Ø (15,8 mm) diameter suction line (insulated) ④
- 3/8" Ø (9,5 mm) liquid line ⑤

Prepare the dispenser.



3.1 Bin Signal Installation

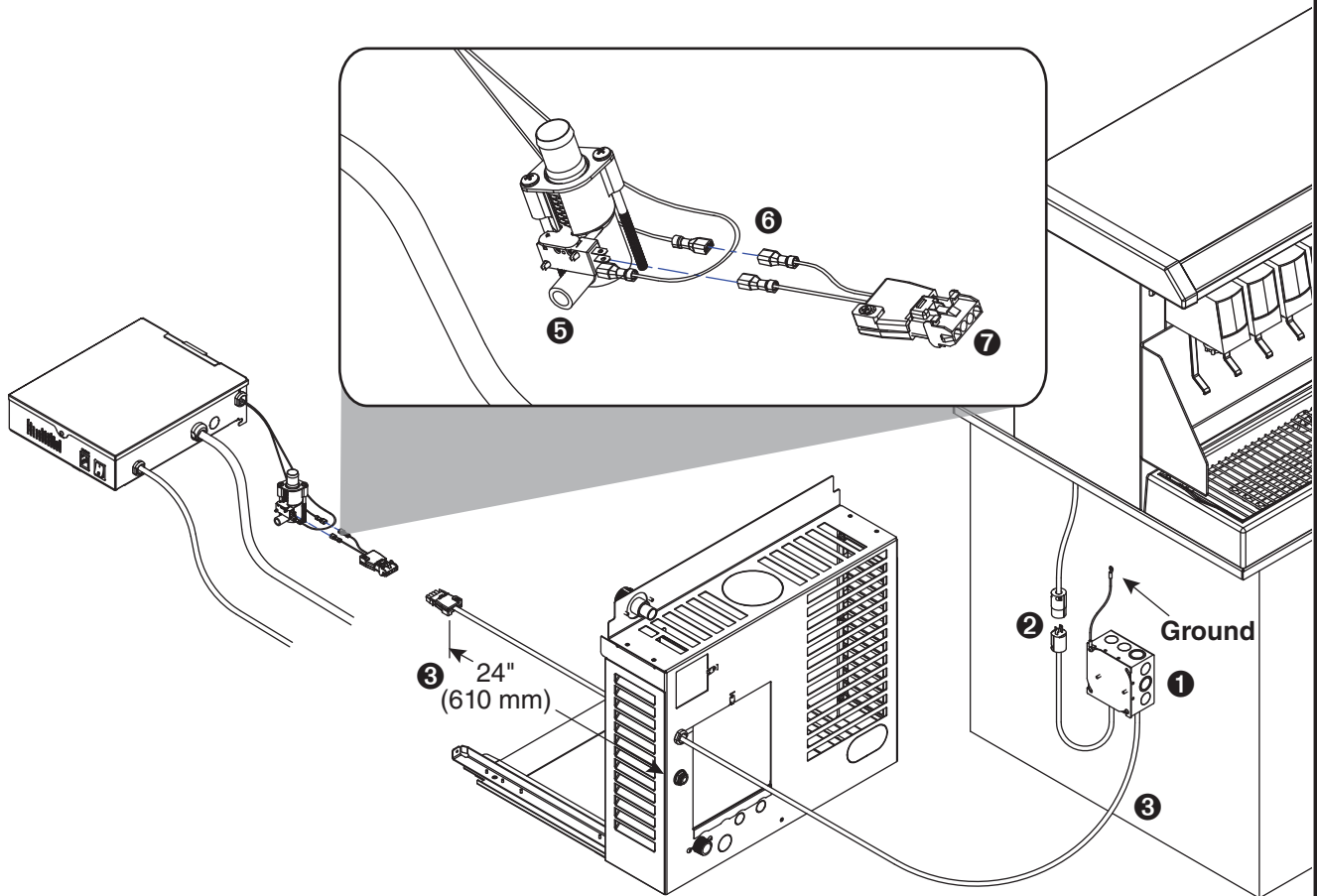

- Mount the electrical box to the side of the Vision dispenser ① to establish a ground connection. **Note:** If a 4 x 4 box is mounted to a non-grounded surface, connect ground wire at an appropriate ground.
- Connect the bin signal plug on the electrical box to the bin signal cord on the bin ②
- Insert 16" (609,6mm) of the long bin signal cable ③ into the hole in the back of the louvered docking station ④ and secure in place with strain relief provided.
- After sliding the ice machine module into the louvered docking station, disconnect one wire from shuttle switch and replace with wire from adapter plug. ⑤
- Connect wire removed from shuttle switch to male connector on adapter plug wire. ⑥
- Complete normal installation procedure for the ice machine using the installation manual that shipped with the ice machine.
- Connect adapter plug into bin signal plug. ⑦

Install the louvered docking assembly.

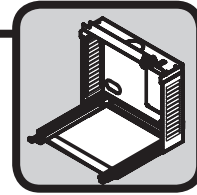

## BEFORE PROCEEDING

Prior to installing the louvered docking assembly, ensure that the drain fitting is oriented (right or left) correctly for your installation. An optional straight drain fitting is also supplied. You may need to remove the back panel of the docking assembly in order to re-orient or change the drain fitting. Replace back panel prior to mounting the docking assembly.

### Wall bracket accessory

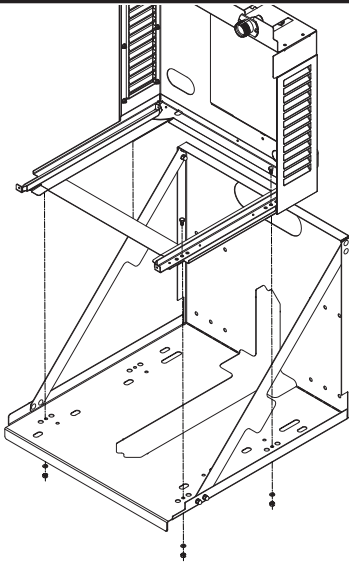

- Mount louvered docking assembly to wall bracket accessory

### Machine stand accessory

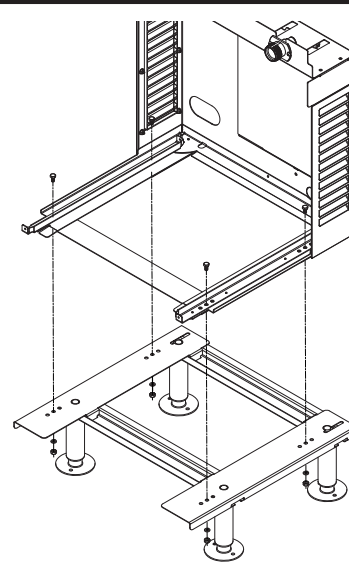

- Mount louvered docking assembly to machine stand accessory

## 4.1 Louvered docking assembly

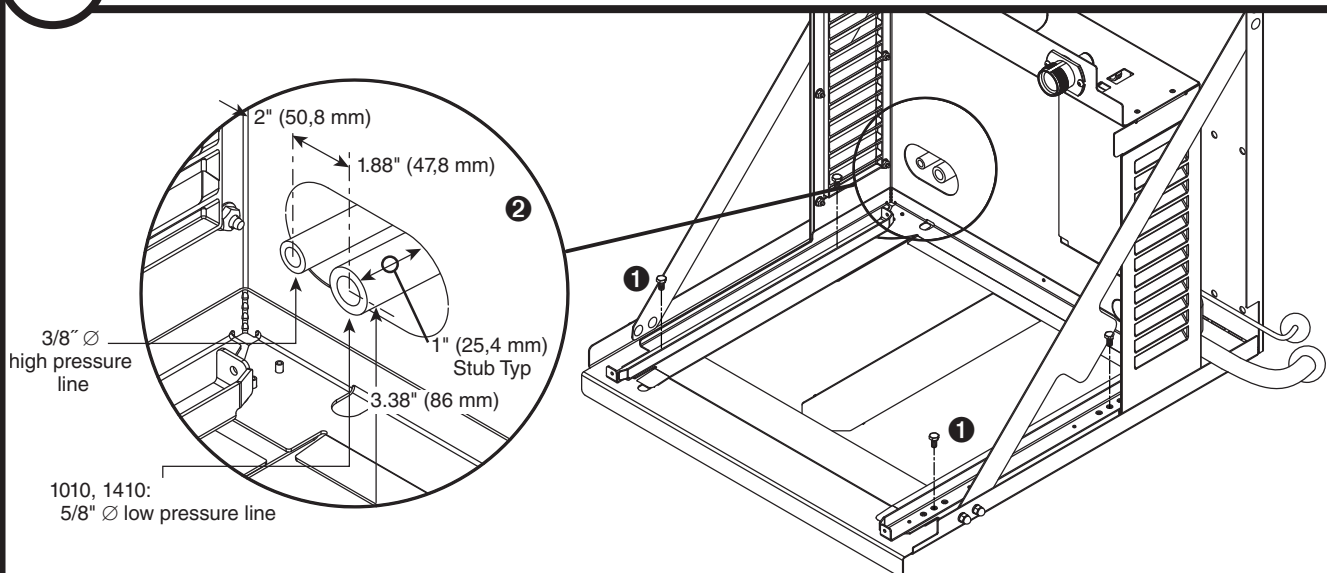

- Mount louvered docking assembly ①
- “Rough-in” the refrigerant piping ②

## 4.2 Undercounter installation requirements

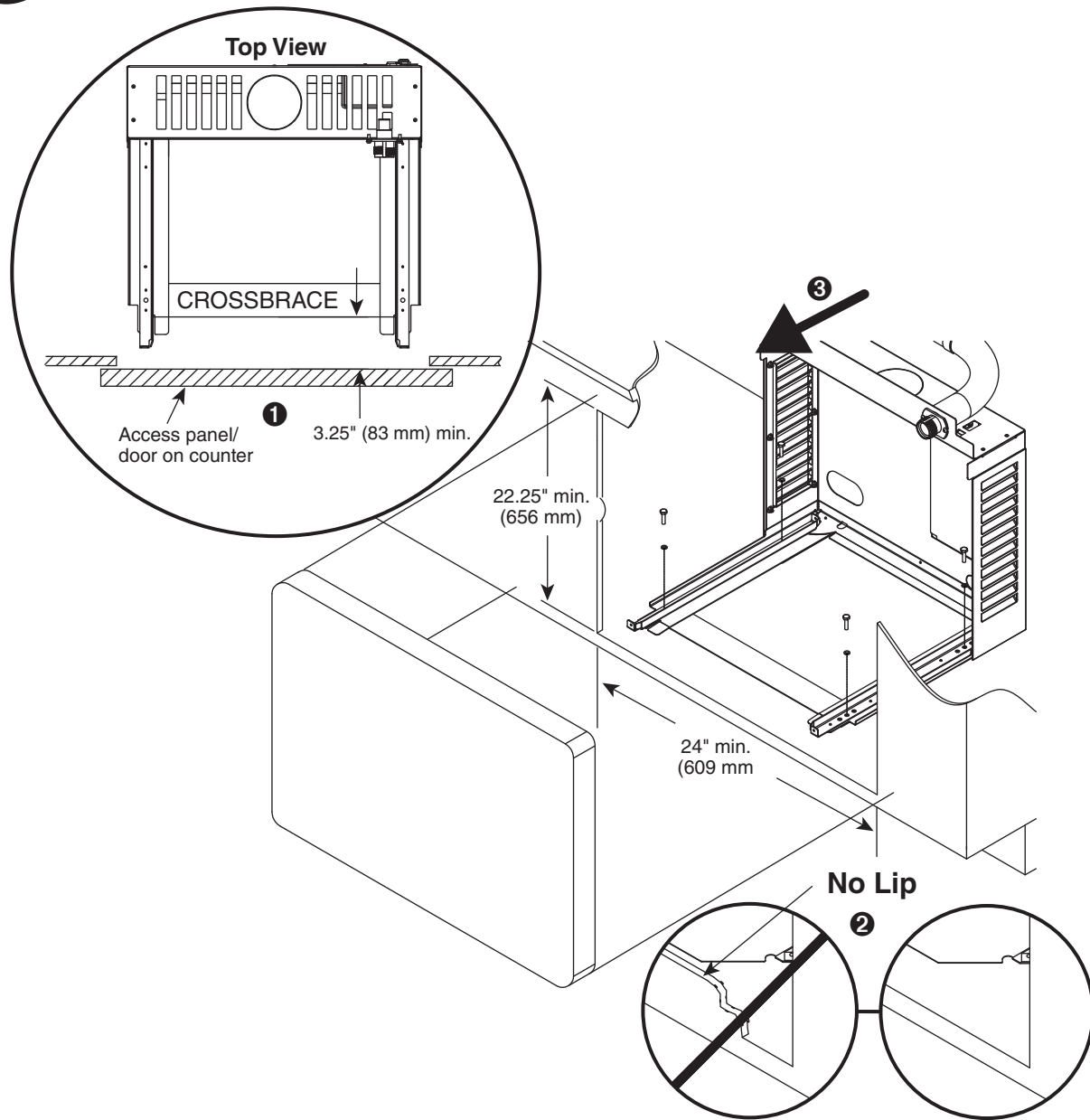

### DOCKING STATION

- Prior to installing the louvered docking assembly, ensure that the drain fitting is oriented (right or left) correctly for your installation. An optional straight drain fitting is also supplied. You may need to remove the back panel of the docking assembly in order to re-orient or change the drain fitting. Replace back panel prior to mounting the docking assembly.
- Position and screw louvered docking assembly to the bottom of counter inside of access panel/door min. of 3.25" (83 mm) from the front edge of the cross brace ①
- The mounting surface for the louvered docking assembly must be solid. Do not mount directly onto runners or channels.
- There must be no lip or edge that would hinder the ice machine from sliding in or out of the louvered docking station ②
- Ice machine must be installed facing forward as shown for service accessibility ③



Install the ice transport tube.

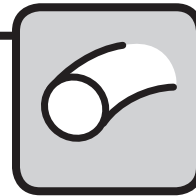

**5.1 Dispenser ice transport tube installation**

**Ice tube retainer bracket**

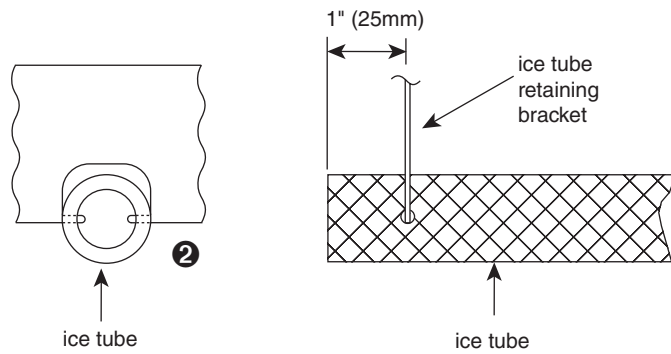

**Front View VU155**

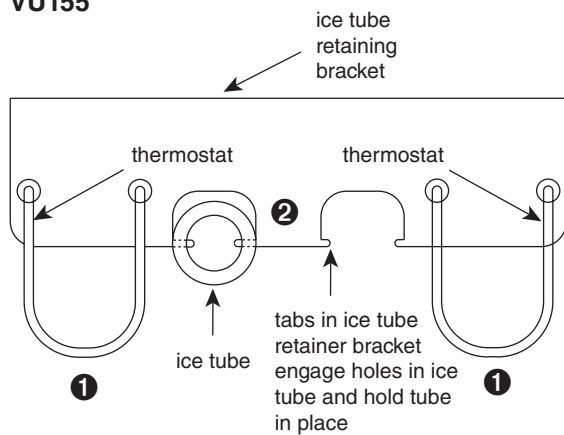

**Front View VU300**

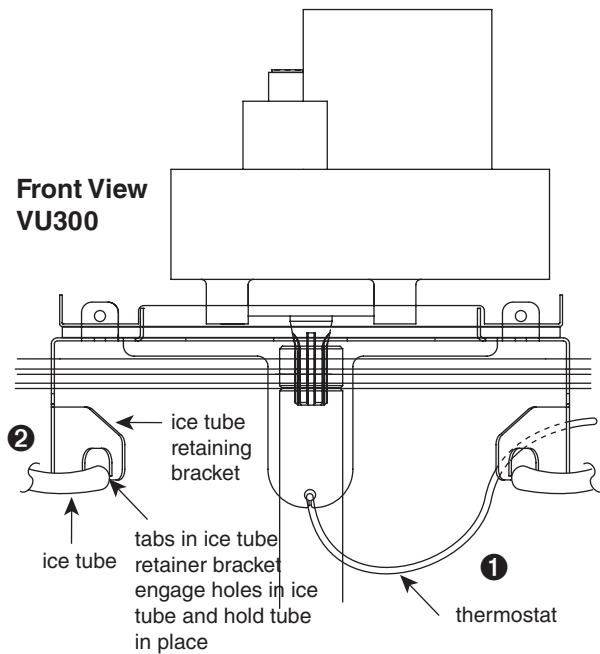

- Push one end of ice transport tube(s) through hole(s) provided in side of dispenser
- Route tube into ice tube bracket inside dispenser and engage bracket tabs in holes located in end of ice transport tube(s) ①
- Verify bin thermostat capillary tube is mounted correctly ②

## 5.2 Ice transport tube installation.

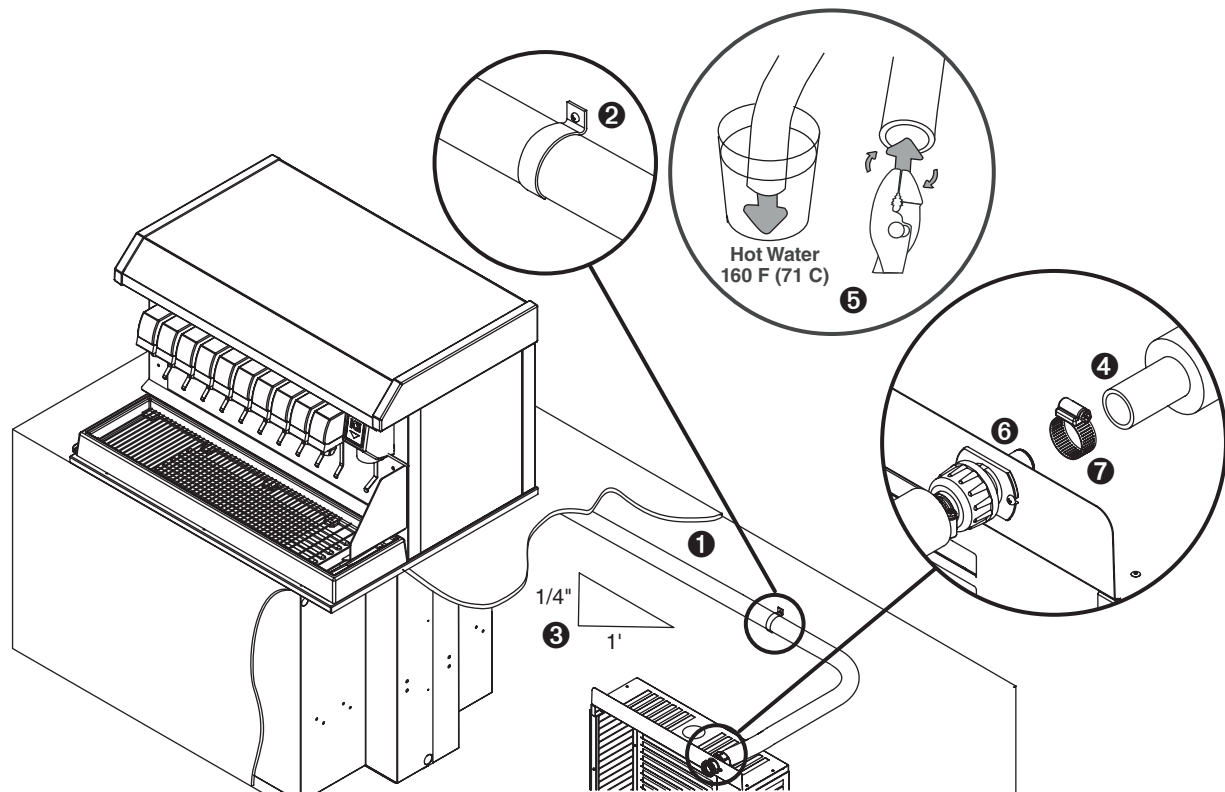

### Ice transport tube tips

- Insulate entire length of ice transport tube ①
- Secure ice transport tube ② as needed to prevent dips and traps from forming. For long tube runs see guide on page 15.
- Pitch ice transport tube at least 1/4" per foot (6,4mm/.3m) ③
- Ice transport tube must drain towards ice machine

### Ice transport tube to Ice machine

- Be sure tube ends are square ④
- Heat end of transport tube in cup of 160 F (71 C) hot water to soften and spread with pliers ⑤ before making connection to ease assembly
- Push ice transport tube onto ice machine nipple ⑥
- Install hose clamp ⑦

Connect utilities to louvered docking assembly.

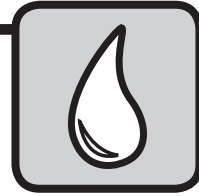

### 6.1 Water and drain

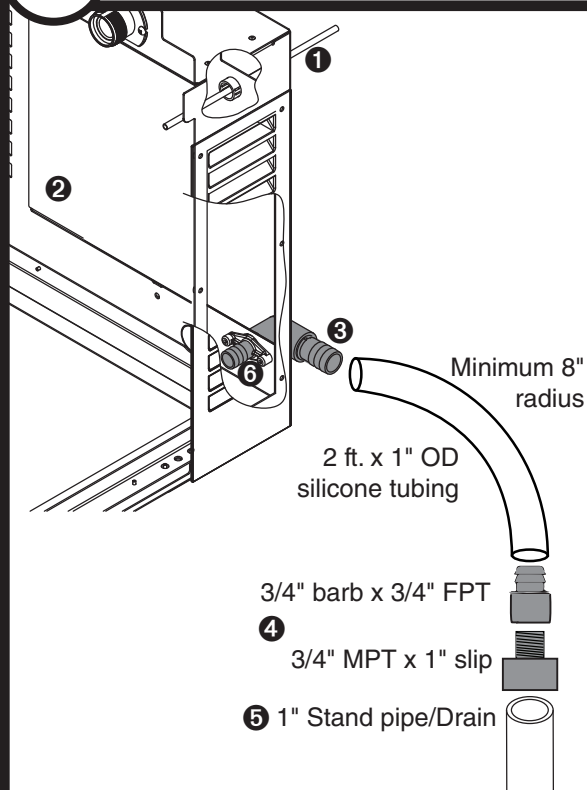

- Rough-in ice machine potable water supply **1**.  
3/8" push-in connection will be made at shut-off valve inside machine
- Remove access panel if necessary **2**.
- Connect the silicone tubing to the ice machine 3/4" drain barb **3**.
- Assemble the 3/4" barb x 3/4" FPT to the 3/4" MPT x 1" slip. Connect the other end of the silicone tubing to the 3/4" barb **4**.
- Connect the 1" slip fitting to the 1" stand pipe/drain **5**.

**Note:** Minimum 8" radius on silicone drain line. Drain line from the ice machine must have at least 1/4" per foot pitch (6,4mm/0,3m).

- Apply Petrol-gel to barbed drain fitting **6**
- Replace access panel.

### 6.2 Refrigerant

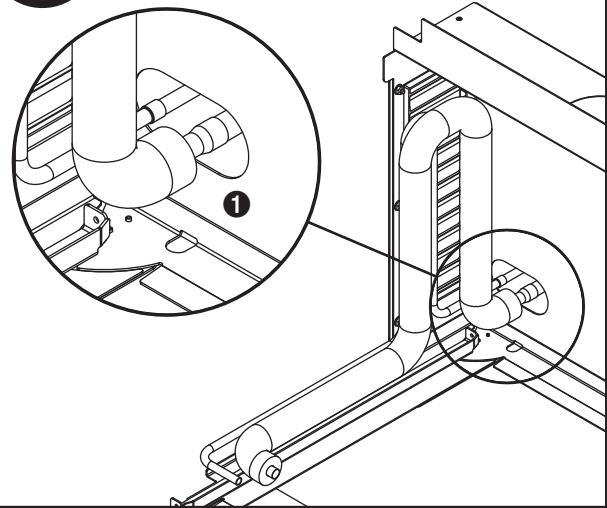

- Braze supplied expandable refrigerant lines in place **1**

Connect louvered docking assembly to ice machine.

## Internal connections **7**

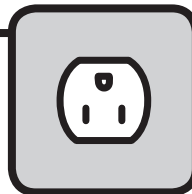

### 7.1 Ice transport tube installation

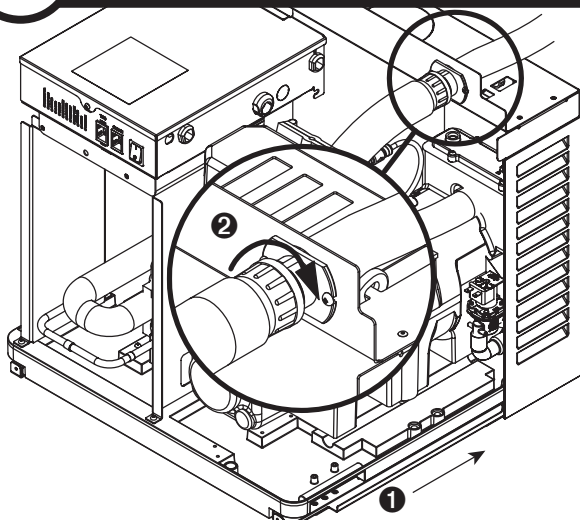

- Slide ice machine into louvered docking assembly *ensuring that drain tube is fully seated on barbed drain fitting* ❶
- Insert ice transport tube all the way into coupling and tighten nut firmly ❷

### 7.2 Water line

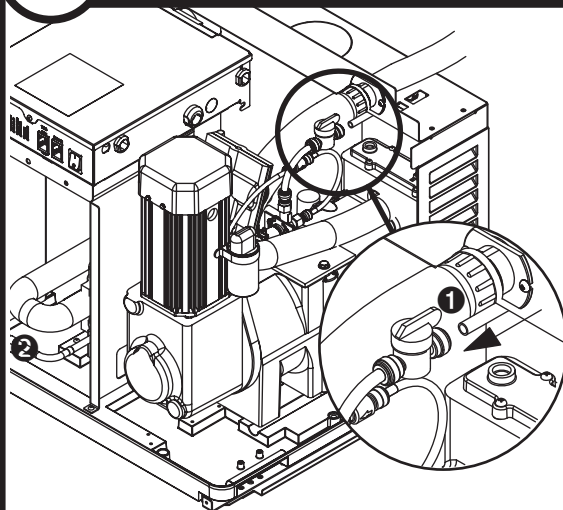

- Insert potable water line into valve ❶

### 7.3 Refrigeration lines

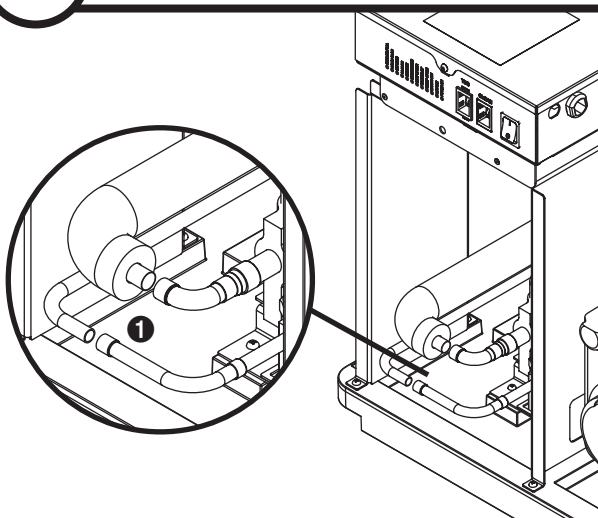

- Braze refrigerant lines ❶

### 7.4 Power cord

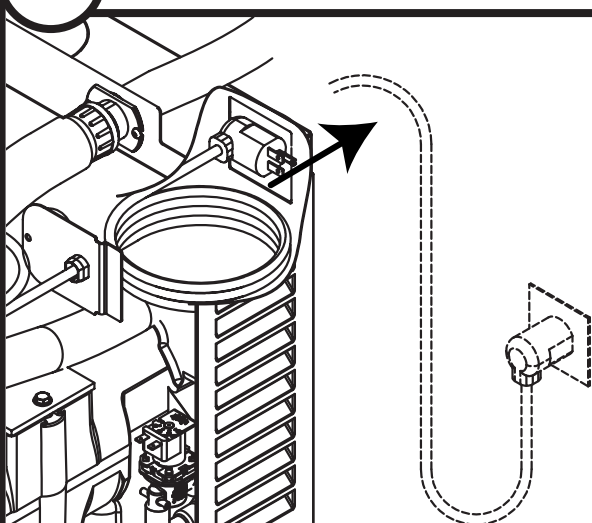

- Remove twist tie
- Carefully pass cord thru opening and plug into wall outlet

### 7.5 Power cord

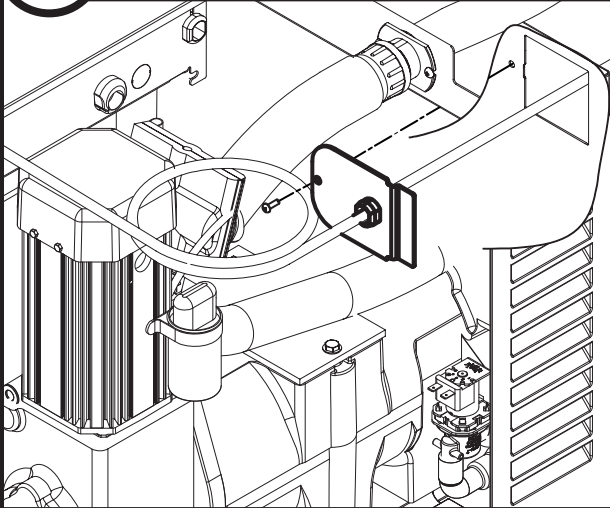

- Position plate into opening and secure with supplied screw

### 7.6 TDS switch

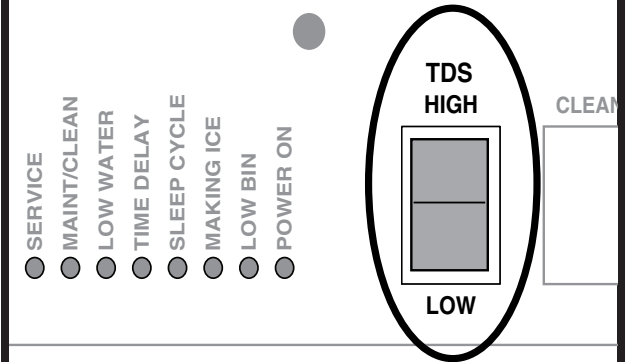

- Set the TDS switch on the electrical box:  
**HIGH:** for extended service life  
**LOW:** for low-scale water

Install front cover to ice machine.

Front cover

8

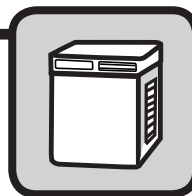

### 8.1 Install condensing unit

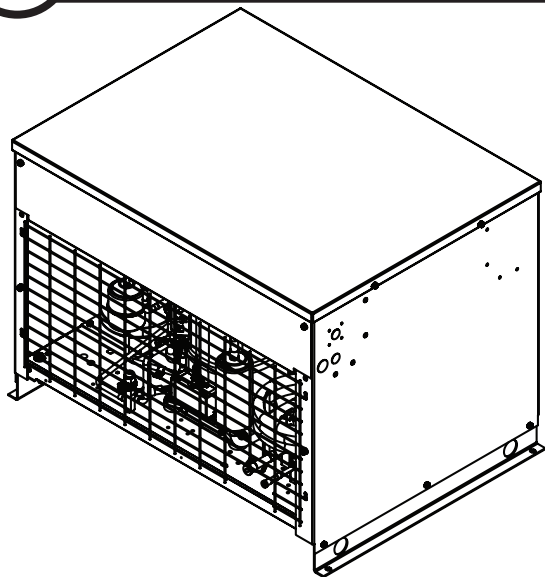

- Complete installation of condensing unit or connection to rack system.
- Required rack system capacity at 0 F (-18 C) evaporator (EPR supplied by installer).

1010N: 7,700 Btu/hr (1940 kcal/hr)

1410N: 10,000 Btu/hr (2519 kcal/hr)

### 8.2 Install ice machine front cover

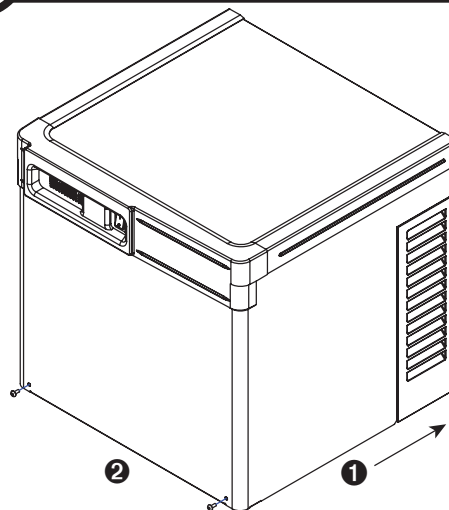

- Slide ice machine cover over machine ensuring that tabs on back of cover slip under louvers on back of louvered docking assembly ①
- Insert and tighten two screws through cover and into louvered docking assembly ②

### NOTICE

**Ice machine MUST be sanitized prior to operation!**

Consult Operation and Service Manual provided with ice machine for sanitizing instructions.

## Long tube run recommendations

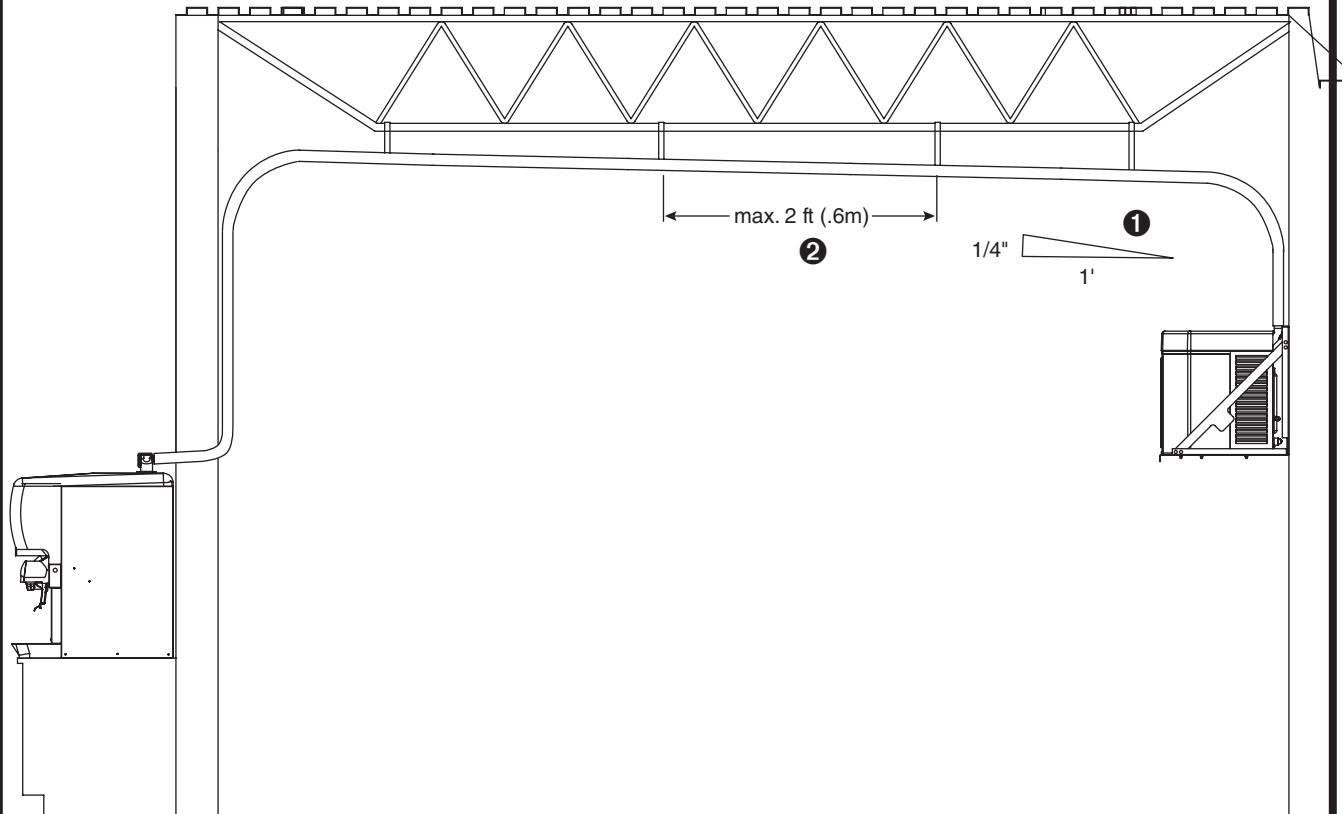

- Pitch ice transport tube to allow melt water to drain towards ice machine ①
- Secure insulated ice transport tube at least every 2 ft (.6m) to prevent dips or traps ②

Horizon, Horizon Elite, Maestro, Harmony, Ice Manager, SafeCLEAN, Sani-Sponge and Vision are trademarks of Follett LLC.  
Chewblet, RIDE and Follett are registered trademarks of Follett LLC, registered in the US.



801 Church Lane • Easton, PA 18040, USA  
Toll free (877) 612-5086 • +1 (610) 252-7301  
[www.follettice.com](http://www.follettice.com)



01113216R01  
© Follet LLC 1/18