

Horizon Elite™ Ice Machine Models with RIDE® Technology Installation Instructions for Ice Manager™ Diverter Valve

HCD/HCF1010RMS, HCD/HCF1410RMS,
HCD1010NMS, HCD1410NMS
(See model number configurator on page 2 for details.)

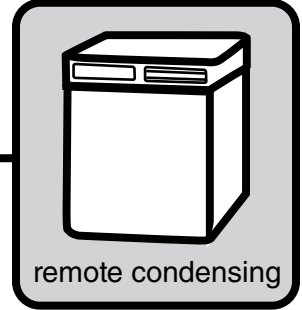

After Serial Number L82638

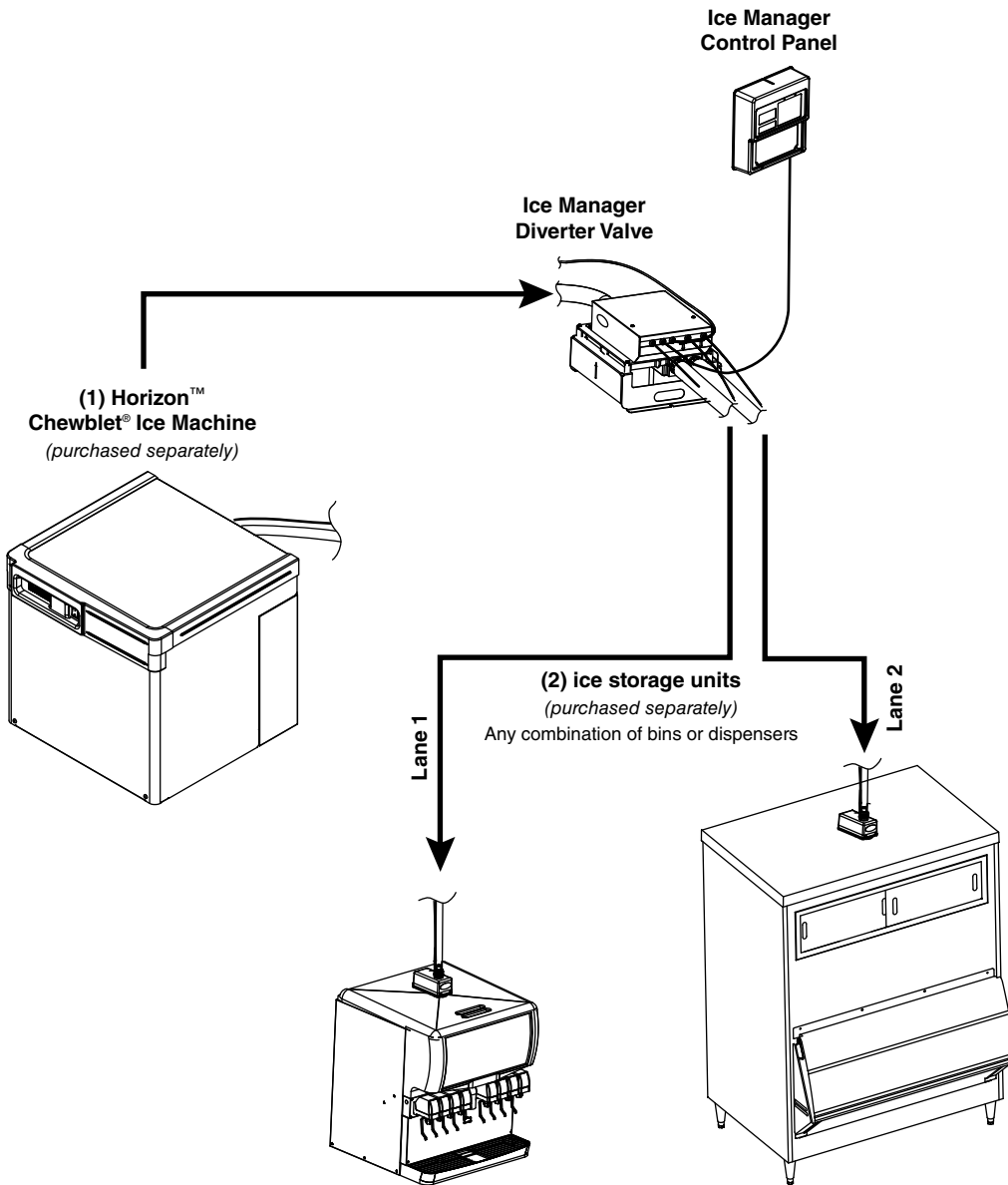

Chewblet® Ice Machine Model Number Configurations

HC
D
1810
A
V
S

Icemaker	Voltage	Series	Condenser	Application	Configuration
MC Maestro™ Chewblet® (425 Series)	C 208-230/60/1 (icemaking head) <i>Self-contained only.</i>	425 up to 425 lbs (193 kg)	A Air-cooled, self-contained W Water-cooled, self-contained	V Vision™ H Harmony™	S RIDE™ (RIDE remote ice delivery equipment)
HC Horizon Chewblet (710, 1010, 1410, 1810, 2110 Series)	D 115/60/1 (icemaking head) <i>Self-contained and remote. If remote unit, high side is 208-230/60/1.</i>	710 up to 675 lbs (306 kg)	R Air-cooled, remote condensing unit N Air-cooled, no condensing unit for connection to parallel rack system	B Ice storage bin J Drop-in M Ice Manager™ diverter valve system P Cornelius Profile PR150	T Top-mount
HM Horizon Micro Chewblet™	E 230/50/1 (icemaking head) <i>Self-contained only.</i> F 115/60/1 (icemaking head) <i>Remote only. High side is 208-230/60/3.</i>	1010 up to 1061 lbs (482 kg) 1410 up to 1466 lbs (665 kg) 1810 up to 1790 lbs (812 kg) 2110 up to 2039 lbs (925 kg)			

Horizon ice machine for use with Ice Manager diverter valve system

The Ice Manager diverter valve system delivers ice to two ice storage units enabling a single Follett Horizon ice machine to meet demand for ice at two locations. The system's sensors monitor ice levels in each storage unit and automatically switch ice delivery to the appropriate location.

After thorough review of Ice Manager site survey, read and complete Horizon ice machine installation sections 1 through 6.

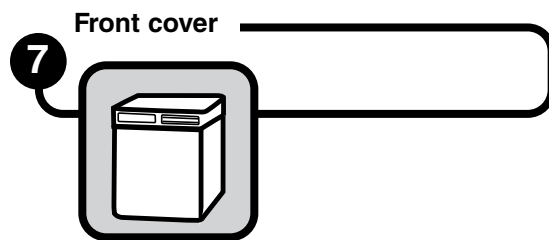
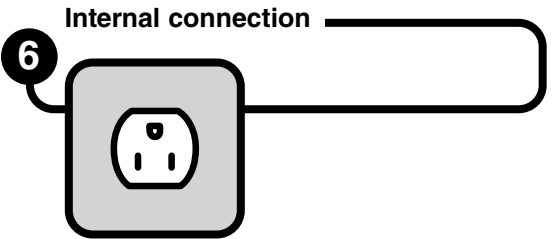
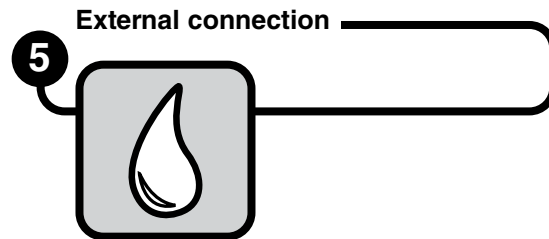
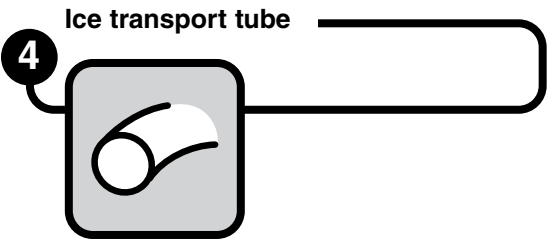
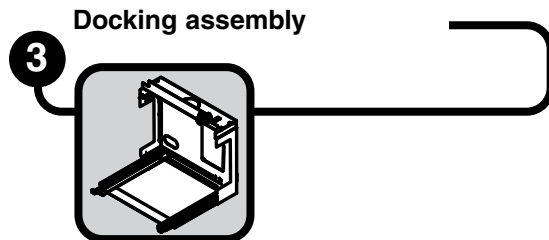
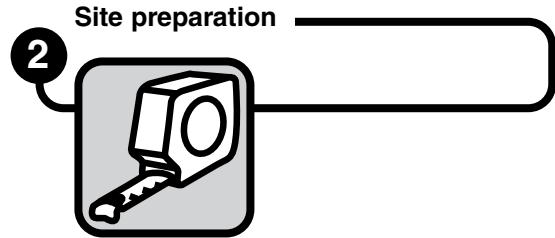
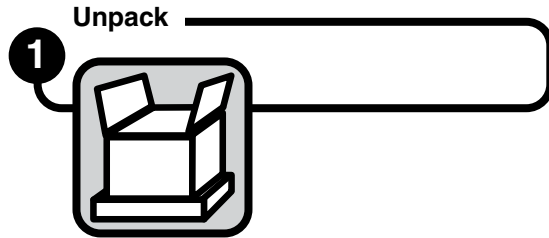

For connection to Ice Manager diverter valve system refer to Ice Manager installation guide.

Carefully unpack and inspect the contents of your Follett ice machine.

Unpack

1



1.1 Unpack ice machine

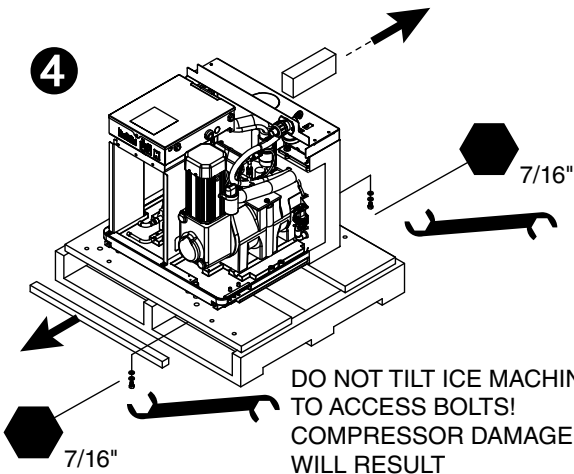
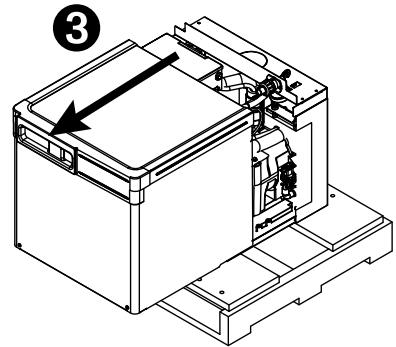
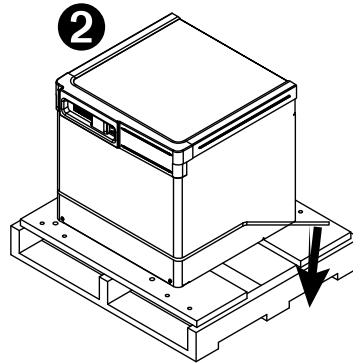
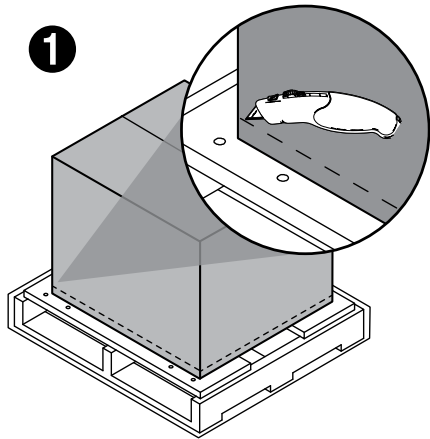

DO NOT TILT ICE MACHINE TO ACCESS BOLTS!
COMPRESSOR DAMAGE WILL RESULT

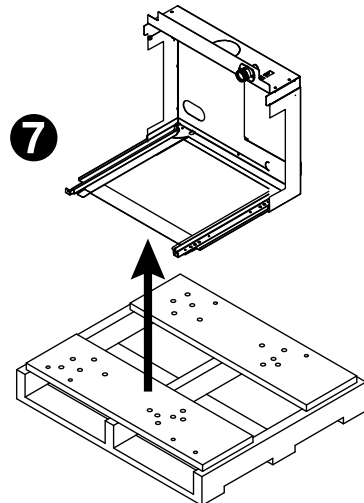
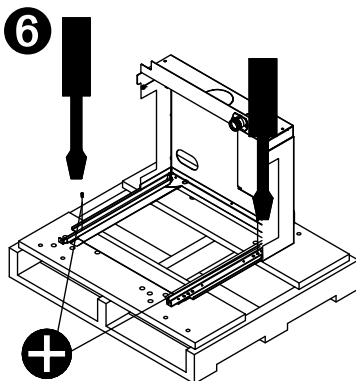
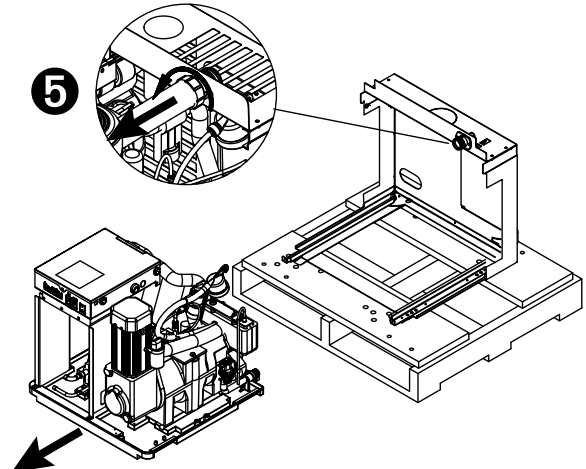

Prepare the installation site.

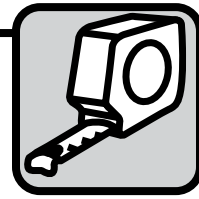

Provide drainage, water supply and electrical power to within 6 feet (2m) of ice machine in accordance with local and national codes. Outdoor installation is not recommended and will void warranty.

2.1 Installation site requirements

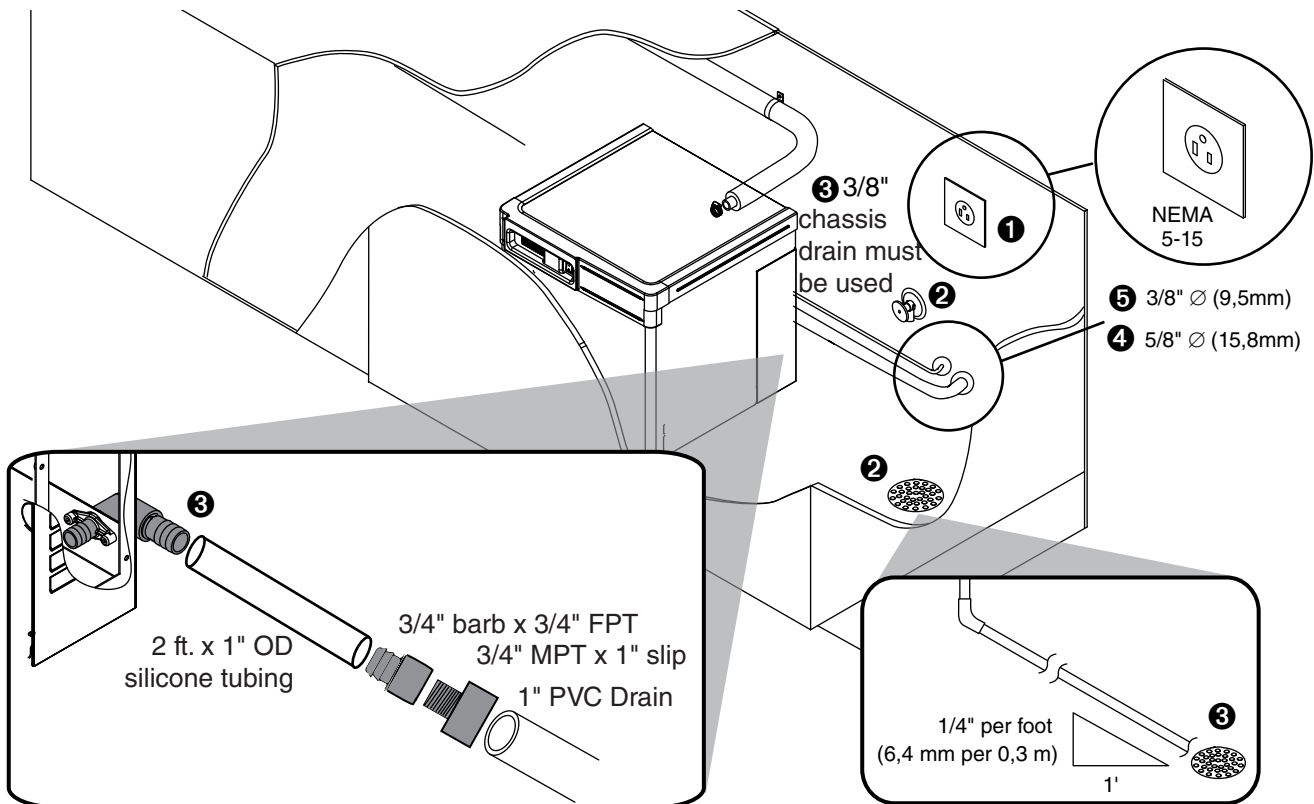

Electrical **1**

- 120/60/1-5 amps

Potable water supply **2** (3/8" push-in connection, 3/8" OD tubing required)

- 10–70 psi (69–483 kpa)
- 45–90 F (7–32 C)
- Follett recommends the use of an in-line water filtration system (item# 00130286)
- This equipment is to be installed with adequate backflow protection to comply with applicable federal, state, and local codes

Drains: **3** 3/4" Barb for silicone drain, 3/8" push-to-connect for chassis drain

- Minimum 8" radius on silicone drain line. Drain line from the ice machine must have at least 1/4" per foot pitch (6,4 mm/0,3 m).

Refrigeration lines **4**

- 5/8" Ø (15,8 mm) diameter suction line (insulated) **4**
- 3/8" Ø (9,5 mm) liquid line **5**

Install the docking assembly.



BEFORE PROCEEDING

Prior to installing the docking assembly, ensure that the drain fitting is oriented (right or left) correctly for your installation. An optional straight drain fitting is also supplied. You may need to remove the back panel of the docking assembly in order to re-orient or change the drain fitting. Replace back panel prior to mounting the docking assembly.

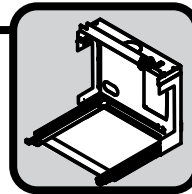

Wall bracket accessory

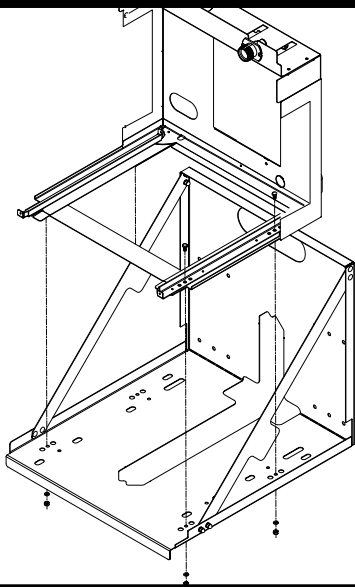

- Mount docking assembly to wall bracket accessory

Machine stand accessory

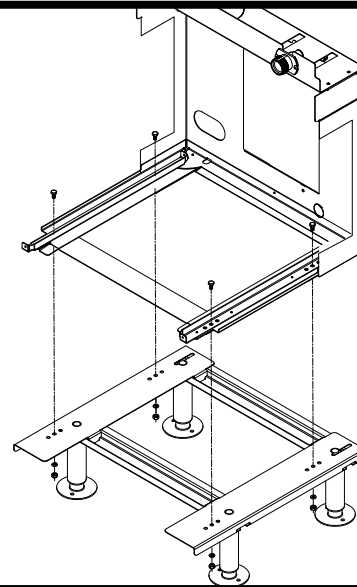

- Mount docking assembly to machine stand accessory

4.1 Docking assembly

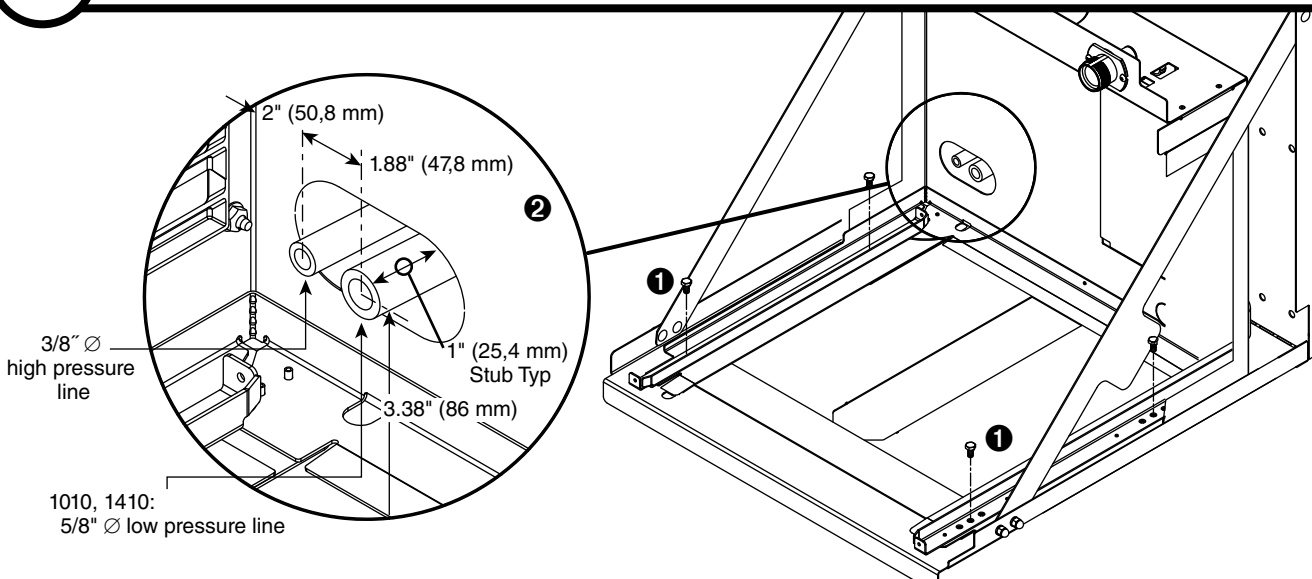

- Mount docking assembly ①
- "Rough-in" the refrigerant piping ②

4.2 Undercounter installation requirements

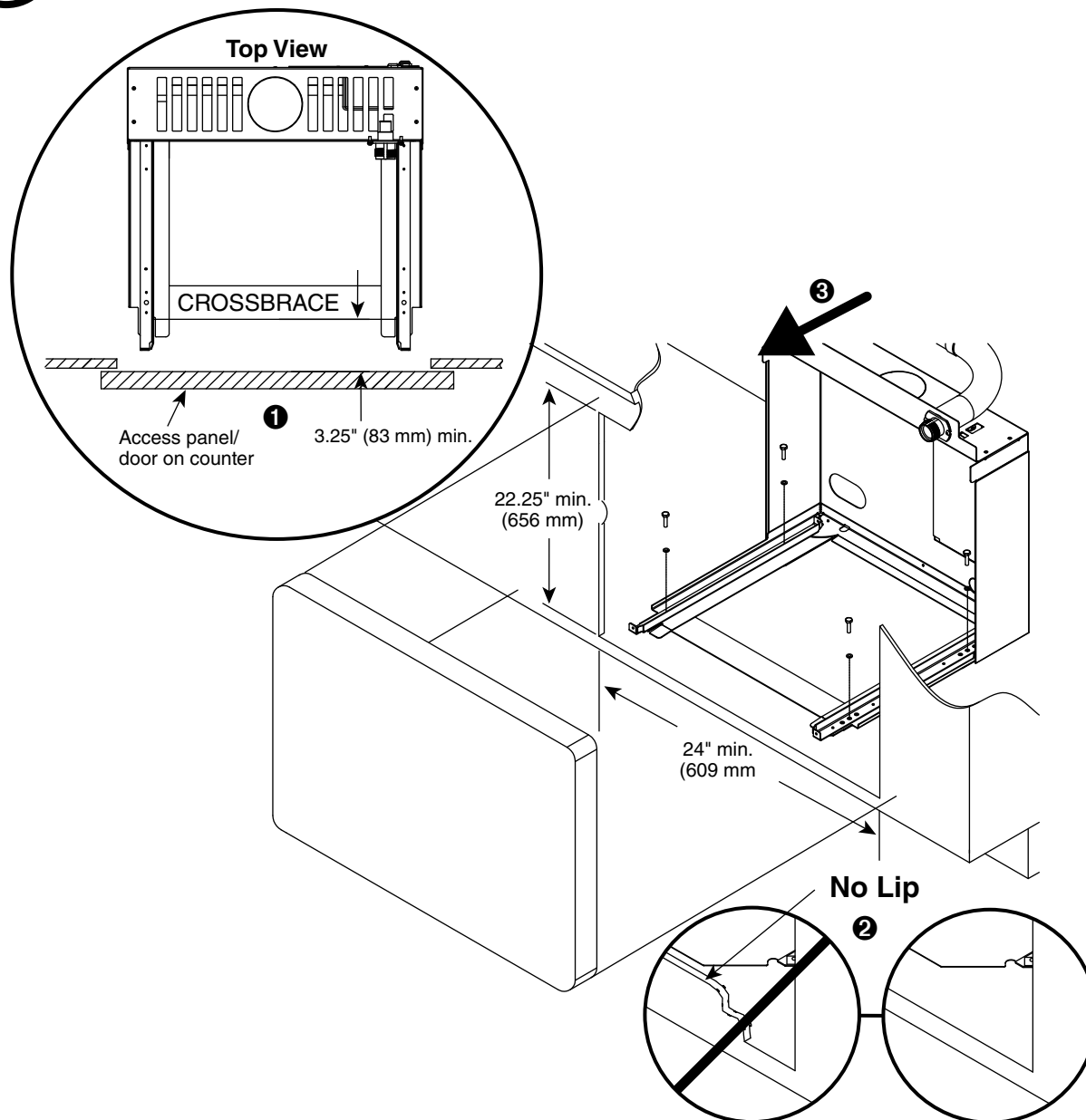

DOCKING STATION

- Prior to installing the docking assembly, ensure that the drain fitting is oriented (right or left) correctly for your installation. An optional straight drain fitting is also supplied. You may need to remove the back panel of the docking assembly in order to re-orient or change the drain fitting. Replace back panel prior to mounting the docking assembly.
- Position and screw docking assembly to the bottom of counter inside of access panel/door min. of 3.25" (83 mm) from the front edge of the cross brace ①
- The mounting surface for the docking assembly must be solid. Do not mount directly onto runners or channels.
- There must be no lip or edge that would hinder the ice machine from sliding in or out of the docking station ②
- Ice machine must be installed facing forward as shown for service accessibility ③

Install the ice transport tube.

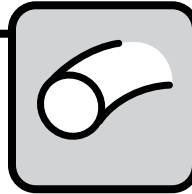

4.2 Ice transport tube installation.

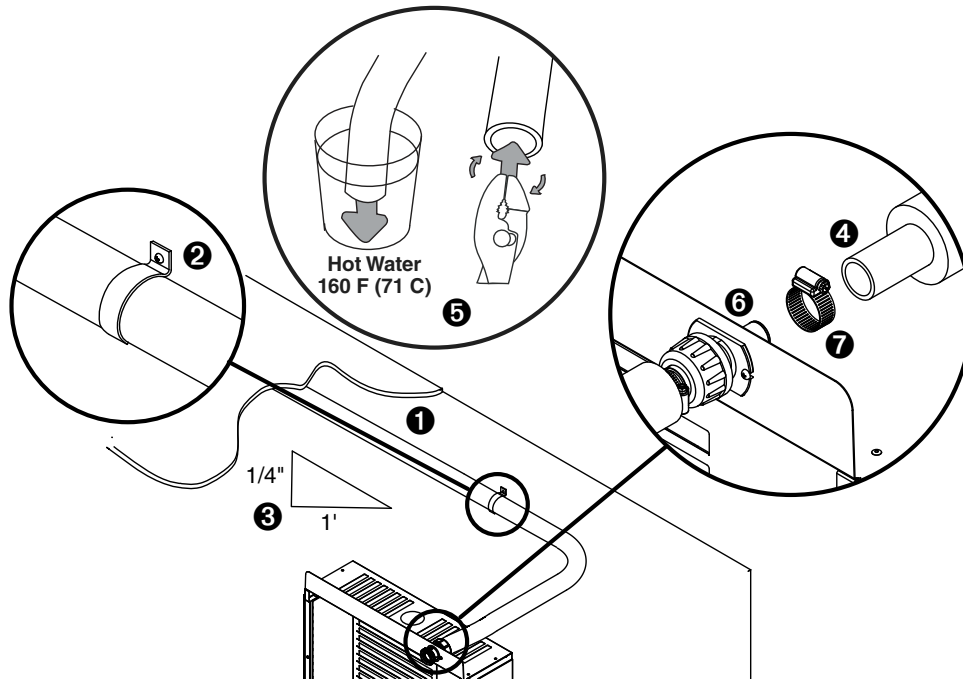

Ice transport tube tips

- Insulate entire length of ice transport tube ①
- Secure ice transport tube ② as needed to prevent dips and traps from forming. For long tube runs see guide on page 15.
- Pitch ice transport tube at least 1/4" per foot (6,4 mm/0,3 m) ③
- Ice transport tube must drain towards ice machine

Ice transport tube to Ice machine

- Be sure tube ends are square ④
- Heat end of transport tube in cup of 160 F (71 C) hot water to soften and spread with pliers ⑤ before making connection to ease assembly
- Push ice transport tube onto ice machine nipple ⑥
- Install hose clamp ⑦

Connect utilities to docking assembly.

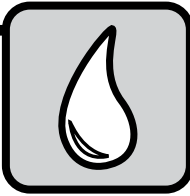

CAUTION

- Plug must be accessible after final installation.

5.1 Water and flush drain

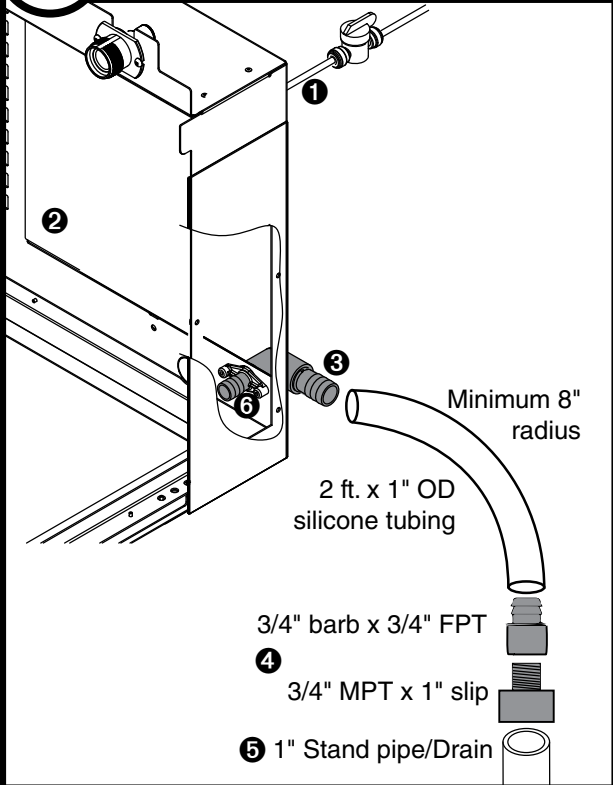

- Rough-in ice machine potable water supply **1**. 3/8" push-in connection will be made at included shut-off valve then at back of docking station into solenoid.
 - Remove access panel if necessary **2**.
 - Connect the silicone tubing to the ice machine 3/4" drain barb **3**.
 - Assemble the 3/4" barb x 3/4" FPT to the 3/4" MPT x 1" slip. Connect the other end of the silicone tubing to the 3/4" barb **4**.
 - Connect the 1" slip fitting to the 1" stand pipe/drain **5**.
- Note:** Minimum 8" radius on silicone drain line. Drain line from the ice machine must have at least 1/4" per foot pitch (6,4 mm/0,3 m).
- Apply Petrol-gel to barbed drain fitting **6**
 - Replace access panel.

Chassis drain plumbing - required

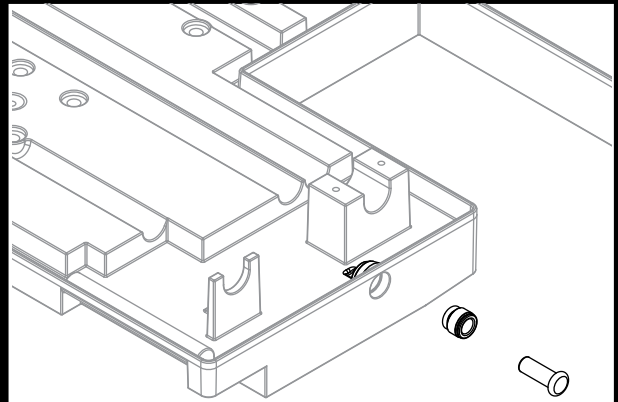

- Plug must be removed from John Guest fitting.
- Route 3/8" drain tubing through knockout in back of docking station and insert fully into John Guest fitting connection at the rear of the machine chassis. Route other end of 3/8" drain tubing to drain.
- Drain must slope 1/4" inch per foot (6 mm per 30,4 cm).

5.2 Refrigerant

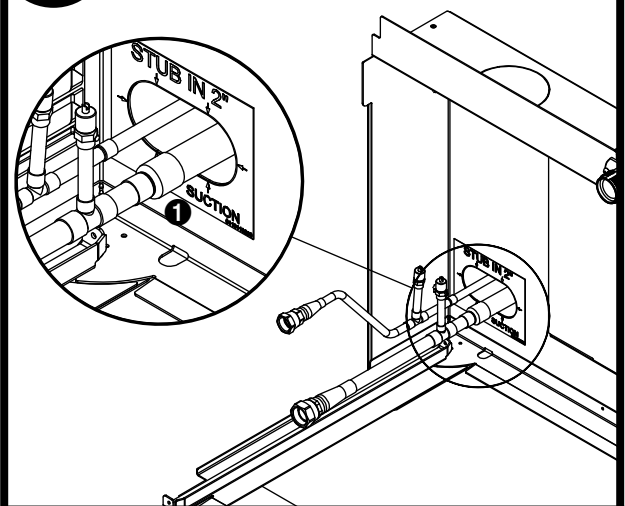

- Braze supplied quick-connect lines onto stub-ins **1**.

Connect docking assembly to ice machine.

Internal connections **6**

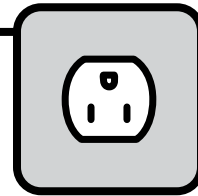

6.1 Ice transport tube installation

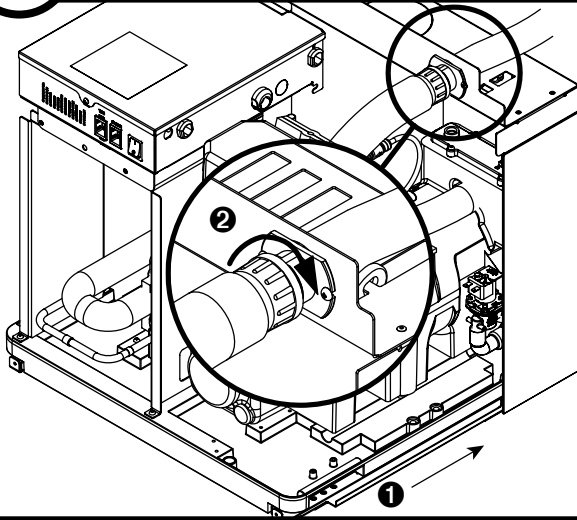

- Slide ice machine into docking assembly ensuring that drain tube is fully seated on barbed drain fitting **1**
- Insert ice transport tube all the way into coupling and tighten nut firmly **2**

6.2 Water solenoid, shut-off valve, and potable water line options

If water solenoid is already mounted to evaporator:

- Insert potable water line into shut-off valve.

If this is an undercounter installation:

- Mount water solenoid atop evaporator and locate the shut-off valve inside the machine. Insert potable water line into shut-off valve.

If water solenoid is not mounted and machine will not be installed under-counter:

- Mount water solenoid to *inside* rear (upper right corner) of docking assembly using one screw.
- Insert potable water line into shut-off valve - locate the shut-off valve *outside* the machine.
- Insert outgoing line from shut-off valve into push-in connection of water solenoid.

6.3 Refrigeration lines

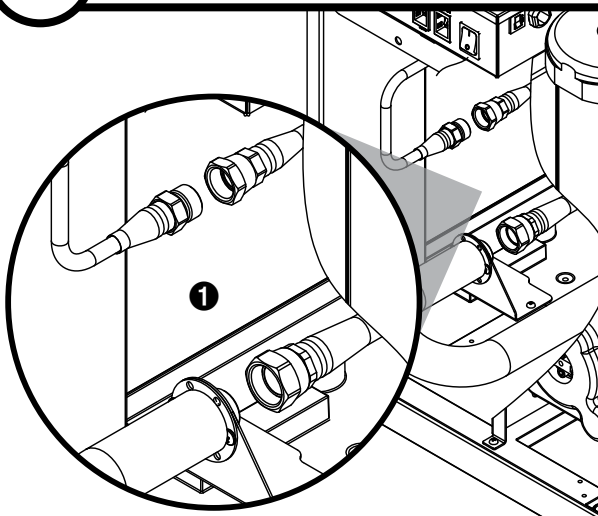

- Evacuate line set.
- Connect self-sealing liquid and suction line fittings **1**

6.4 Power cord

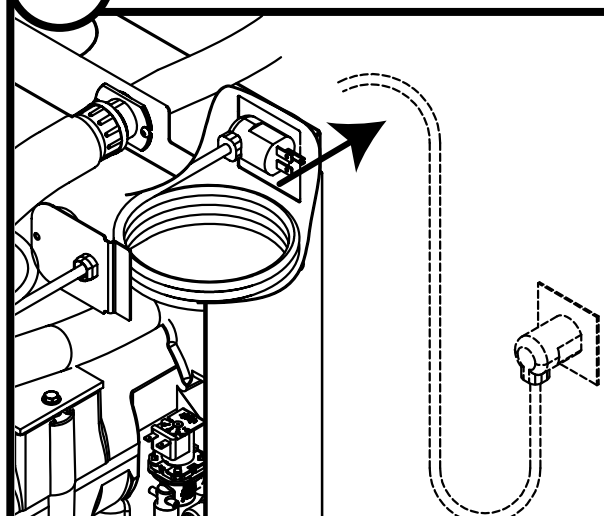

- Remove twist tie
- Carefully pass cord through opening and plug into wall outlet

6.5 Power cord

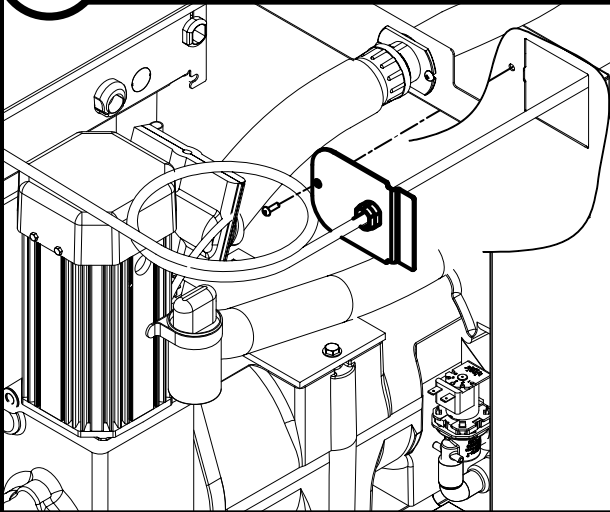

- Position plate into opening and secure with supplied screw

6.6 TDS switch

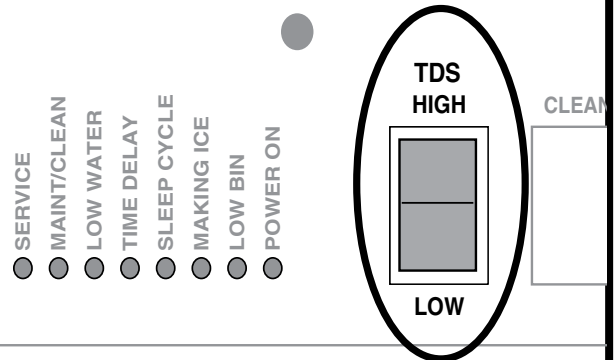

- Set the TDS switch on the electrical box:
HIGH: for extended service life
LOW: for low-scale water

Install front cover to ice machine.

Front cover

7

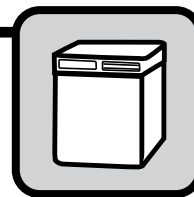

7.1 Install condensing unit

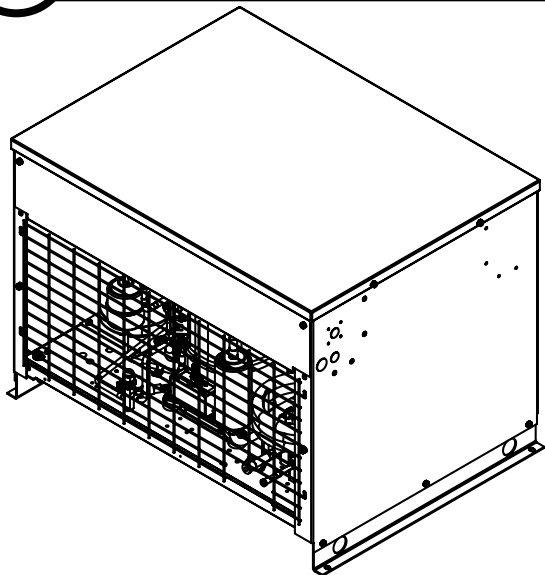

- Complete installation of condensing unit or connection to rack system.
- Required rack system capacity at 0 F (-18 C) evaporator (EPR supplied by installer).
1010N: 7,700 Btu/hr (1940 kcal/hr)
1410N: 10,000 Btu/hr (2519 kcal/hr)

7.2 Install ice machine front cover

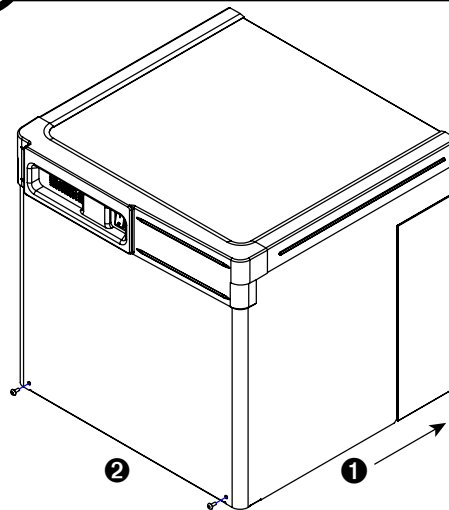

- Slide ice machine cover over machine ①
- Insert and tighten two screws through cover and into docking assembly ②

NOTICE

Ice machine MUST be sanitized prior to operation!

Consult Operation and Service Manual provided with ice machine for sanitizing instructions.

Long tube run recommendations

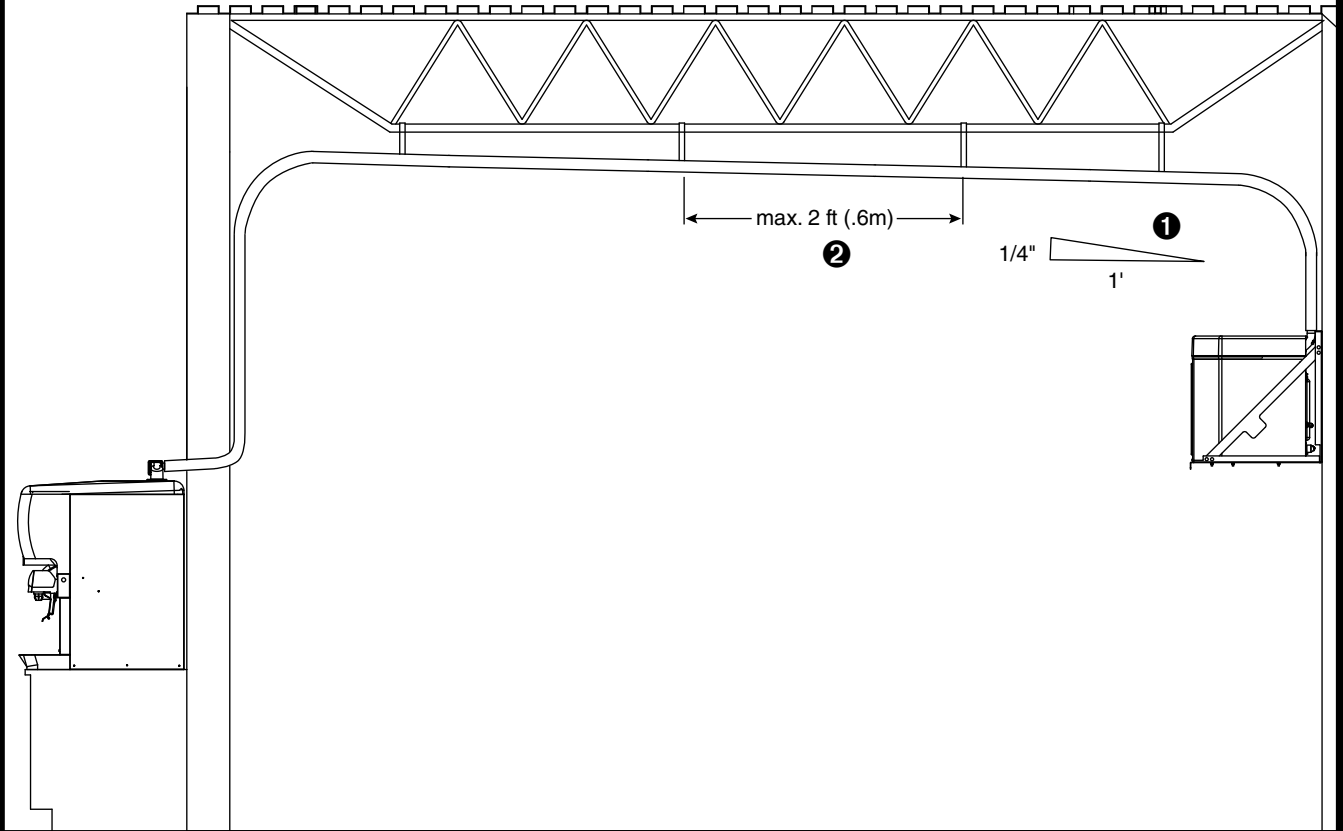

- Pitch ice transport tube to allow melt water to drain towards ice machine ①
- Secure insulated ice transport tube at least every 2 ft (0,6 m) to prevent dips or traps ②

Maestro, Micro Chewblet, Vision, Harmony, Ice Manager, Horizon, Horizon Elite are trademarks of Follett Products LLC.
Chewblet, RIDE, Follett are registered trademarks of Follett Products LLC.



801 Church Lane • Easton, PA 18040, USA
Toll free (877) 612-5086 • +1 (610) 252-7301
www.follettice.com

01113372R04
© Follett Products LLC 2/22