

# Horizon Elite™ Ice Machine Models with RIDE™ Technology Installation Instructions for Cornelius PR150

HCD710APS, HCC1010APS, HCC1410APS, HCC1010WPS, HCC1410WPS,  
(See model number configurator on page 2 for details.)

Order parts online  
[www.follettice.com](http://www.follettice.com)

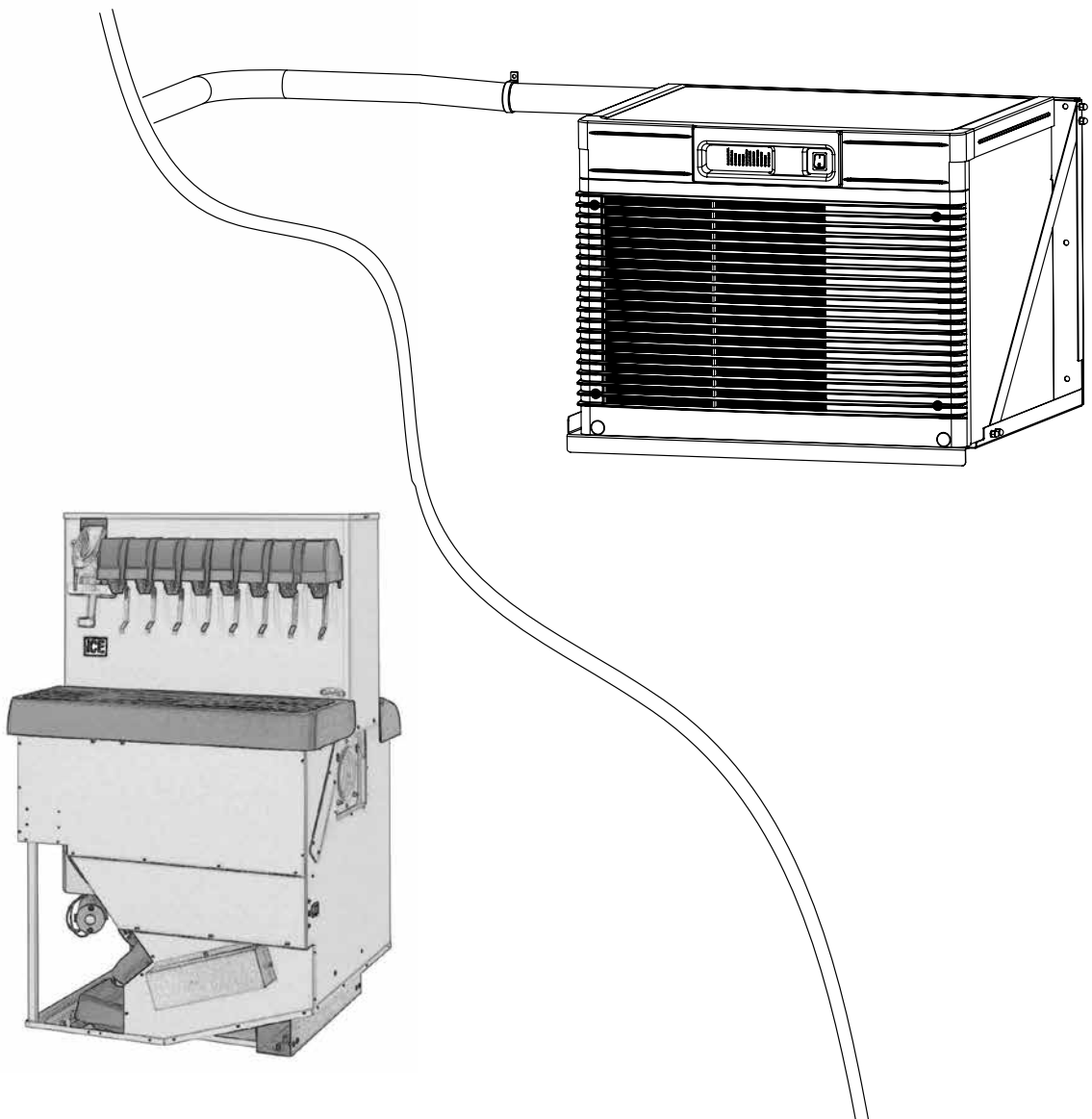
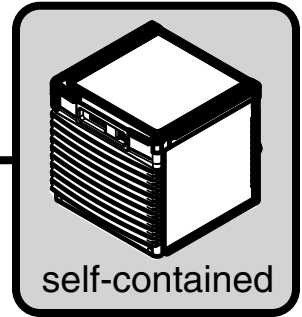

### Chewblet® Ice Machine Model Number Configurations

HC
D
1810
A
V
S

Icemaker	Voltage	Series	Condenser	Application	Configuration
MC Maestro™ Chewblet® (425 Series)	C 208-230/60/1 (icemaking head) <i>Self-contained only.</i>	425 up to 425 lbs (193 kg)	A Air-cooled, self-contained	V Vision™	S RIDE™
HC Horizon Chewblet (710, 1010, 1410, 1810, 2110 Series)	D 115/60/1 (icemaking head) <i>Self-contained and remote. If remote unit, high side is 208-230/60/1.</i>	710 up to 675 lbs (306 kg)	W Water-cooled, self-contained	H Harmony™	(RIDE remote ice delivery equipment)
HM Horizon Micro Chewblet™	E 230/50/1 (icemaking head) <i>Self-contained only.</i>	1010 up to 1061 lbs (482 kg)	R Air-cooled, remote condensing unit	B Ice storage bin	
	F 115/60/1 (icemaking head) <i>Remote only. High side is 208-230/60/3.</i>	1410 up to 1466 lbs (665 kg)	N Air-cooled, no condensing unit for connection to parallel rack system	J Drop-in	T Top-mount
		1810 up to 1790 lbs (812 kg)		M Ice Manager™ diverter valve system	
		2110 up to 2039 lbs (925 kg)		P Cornelius Profile PR150	

Read and complete the following 8 installation steps

1 **Unpack** \_\_\_\_\_



2 **Site preparation** \_\_\_\_\_



3 **Dispenser preparation** \_\_\_\_\_



4 **Docking assembly** \_\_\_\_\_

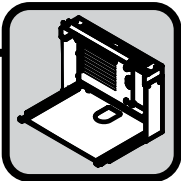

5 **Ice transport tube** \_\_\_\_\_



6 **External connection** \_\_\_\_\_



7 **Internal connection** \_\_\_\_\_

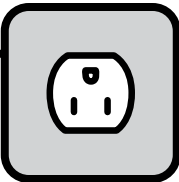

8 **Front cover** \_\_\_\_\_

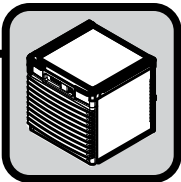

Carefully unpack and inspect the contents of your Follett ice machine.

Unpack

1



1.1 Unpack ice machine

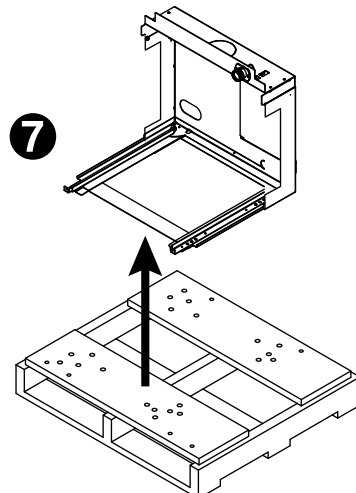
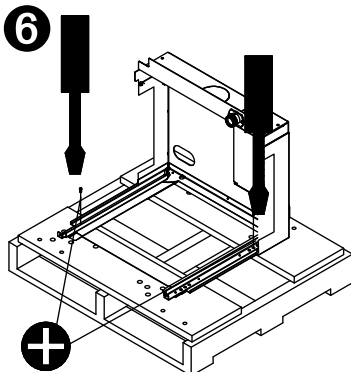
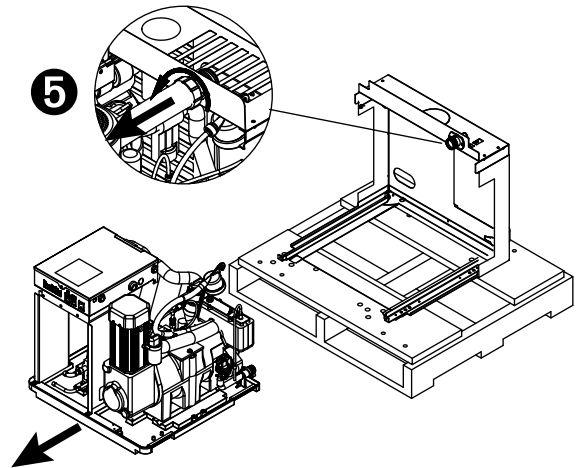
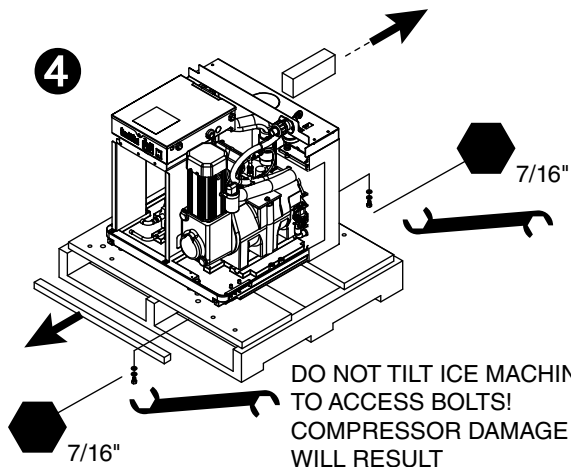
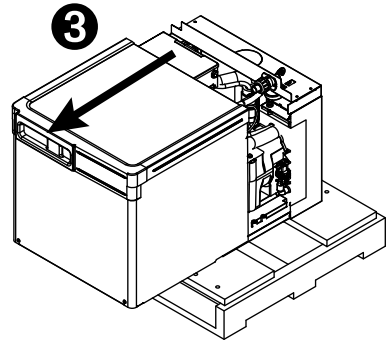
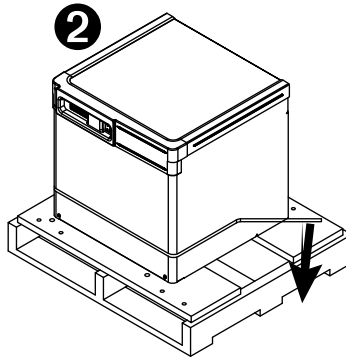
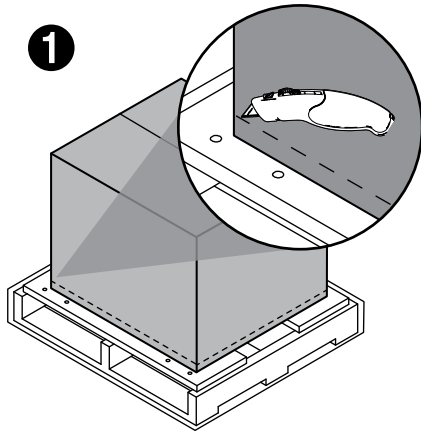

## Prepare the installation site.

Provide drainage, water supply and electrical power to within 6 feet (2m) of ice machine in accordance with local and national codes. Outdoor installation is not recommended and will void warranty.

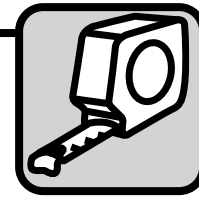

## 2.1 Installation site requirements

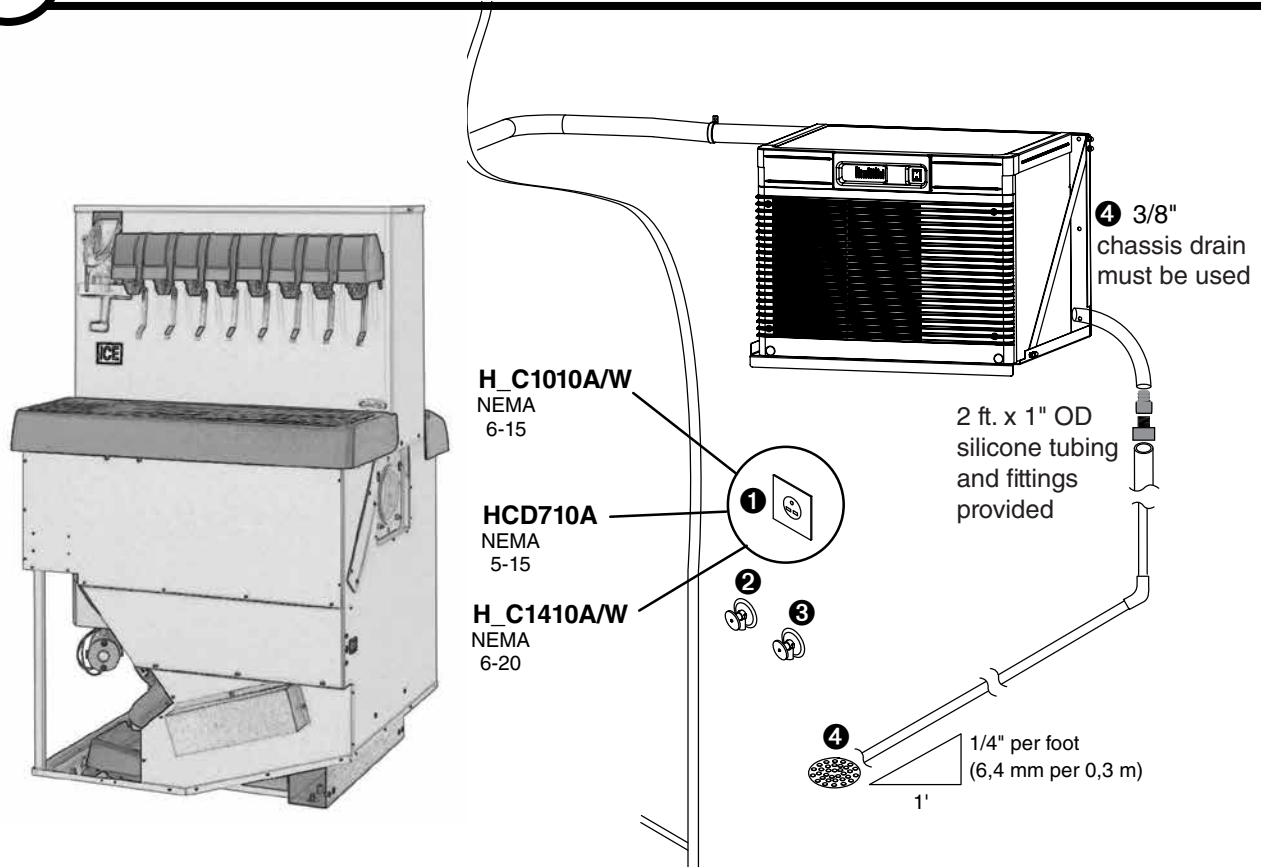

### Electrical ①

- H\_C1010/1410(A/W)JS 208-230/60/1-15A
- HCD710APS 115/60/1-15A

### Potable water supply ② (3/8" push-in connection, 3/8" OD tubing required)

- 10-70 psi (69-483kpa)
- 45 to 90 F (7 to 32 C)
- Follett recommends the use of an in-line water filtration system (item# 00130286)
- This equipment is to be installed with adequate backflow protection to comply with applicable federal, state, and local codes

### Condenser water supply for water-cooled systems ③ (1/4" FPT inlet, 1/4" FPT outlet)

- 10 psi min.; 150 psi max. (69kpa min.; 1034kpa max.)
- 45 to 90 F (7 to 32 C)
- 1.5 gallons per minute (5.68 liters per minute)

### Drains: ④ 3/4" Barb for silicone drain, 3/8" push-to-connect for chassis drain

- Minimum 8" radius on silicone drain line. Drain line from the ice machine must have at least 1/4" per foot pitch (6,4 mm/0,3 m).

Prepare the dispenser.

## Dispenser preparation

3

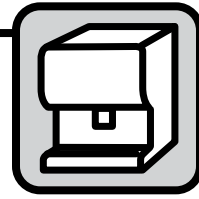

3.1

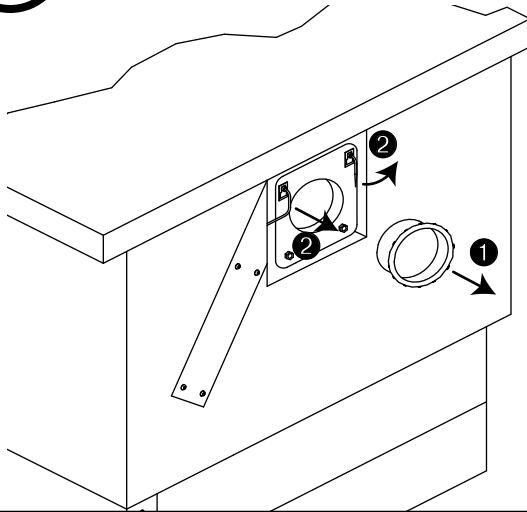

- Remove ice entry cover plate 1
- Remove bin thermostat capillary tube from bracket 2

3.2

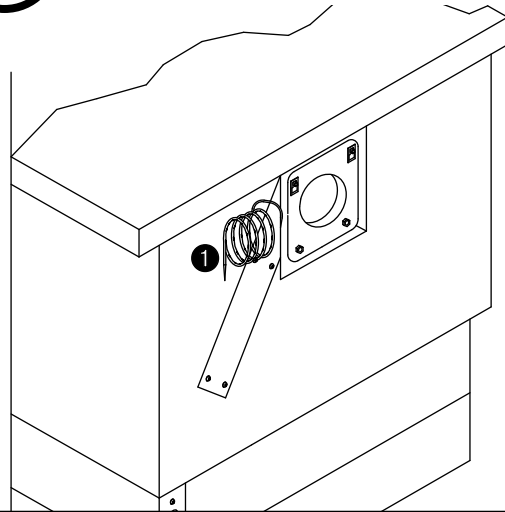

- Coil capillary tube and secure away from bin fill opening 1

3.3

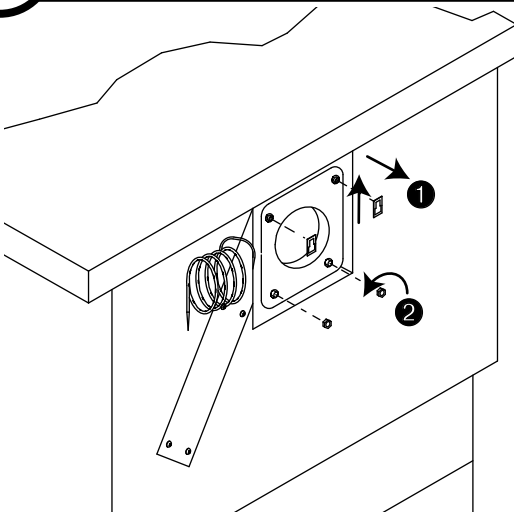

- Remove retaining clips 1 and deflector nuts 2

3.4

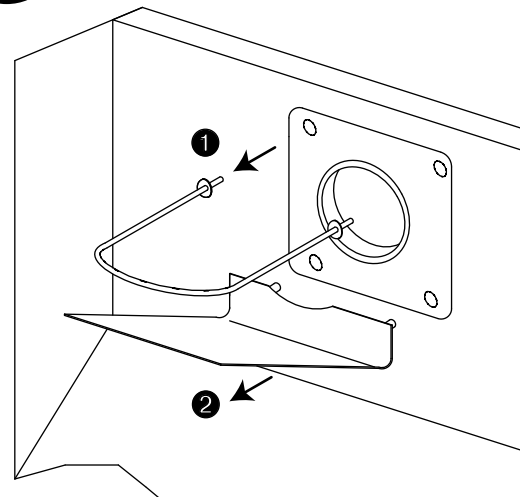

- Remove capillary tube bracket 1 and deflector (Fig. 4.2) from inside ice storage hopper 2

3.5

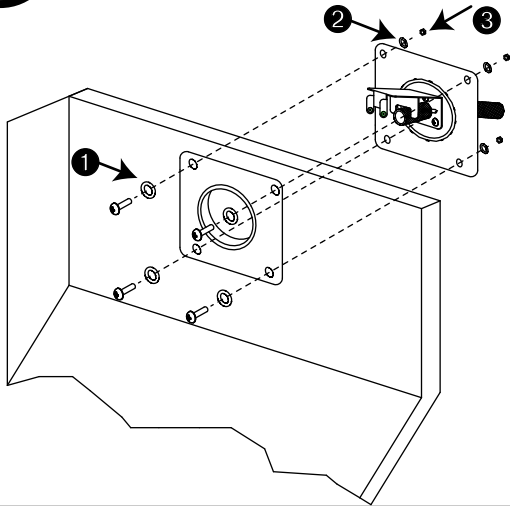

- Mount cover plate/transport tube assembly on outside of dispenser using screws, flat washers ①, lock washers ② and nuts provided ③

3.6

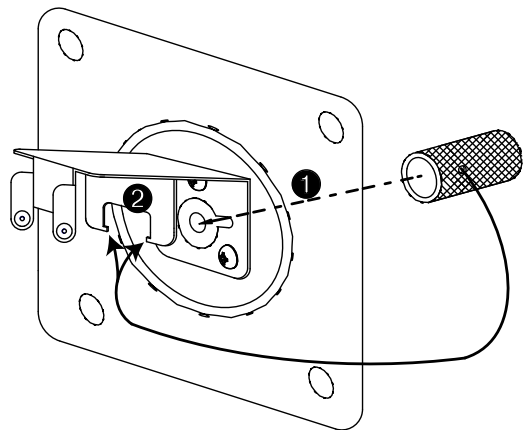

- Insert end of ice transport tube (with retaining holes) through hole in center of cover plate assembly ①
- Secure ice transport tube (holes) to retaining tabs on bracket ②

3.7

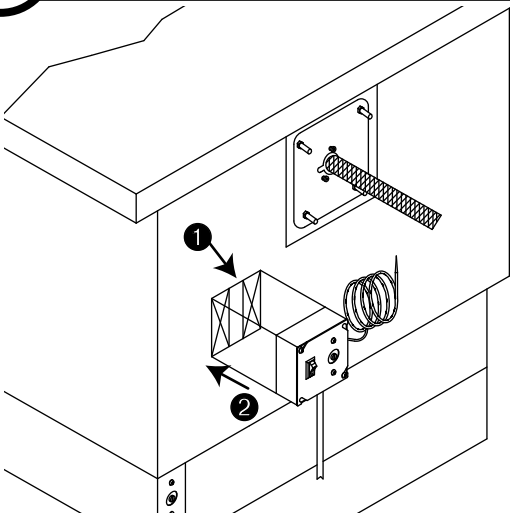

- Thoroughly clean outer wall of dispenser in area indicated ①
  - Peel backing from adhesive and mount bin thermostat box to dispenser wall ②
- Note:** Once adhesive on thermostat box contacts dispenser cabinet it can not be re-positioned.

3.8

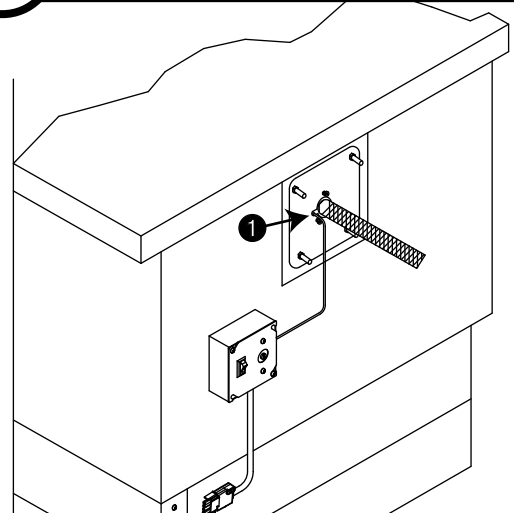

- Insert bin thermostat capillary tube through hole in gasket as indicated ①

3.9

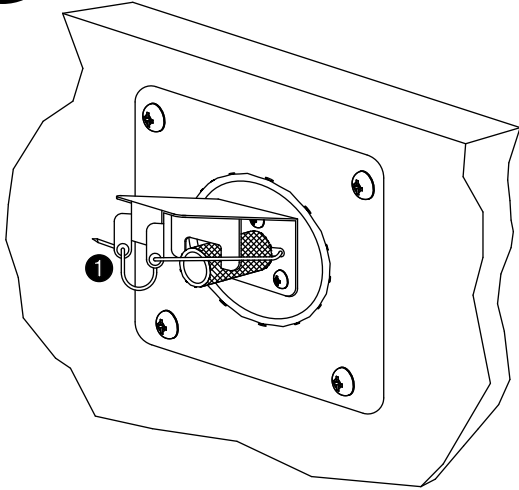

- Route thermostat capillary tube through mounting bracket grommets as shown ❶

3.10

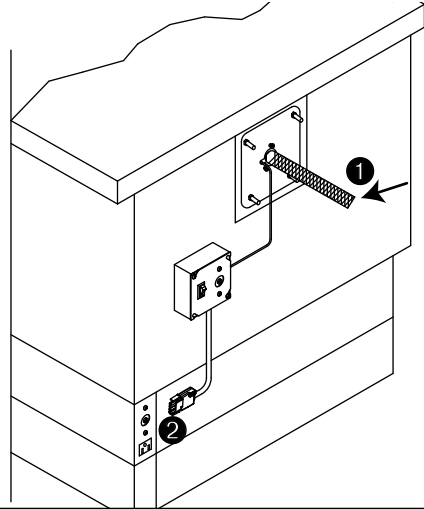

- Insulate entire length of ice transport tube ❶ and route to icemaker in accordance with directions in Horizon installation instructions
- Route bin signal wire to icemaker ❷

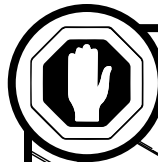

### BEFORE PROCEEDING

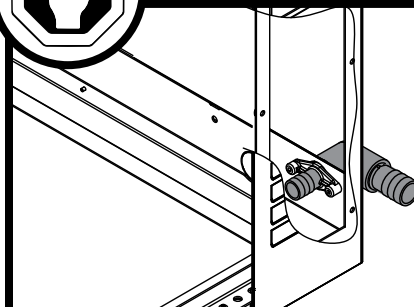

Prior to installing the docking assembly, ensure that the drain fitting is oriented (right or left) correctly for your installation. An optional straight drain fitting is also supplied. You may need to remove the back panel of the docking assembly in order to re-orient or change the drain fitting. Replace back panel prior to mounting the docking assembly.



Install the docking assembly.

**WARNING**

- Docking station must be secured in accordance with these instructions to ensure ice machine stability.
- Ventilation openings in the docking station should be clear of obstruction

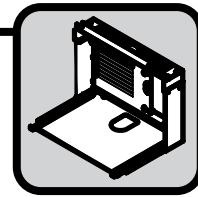

**Wall bracket accessory**

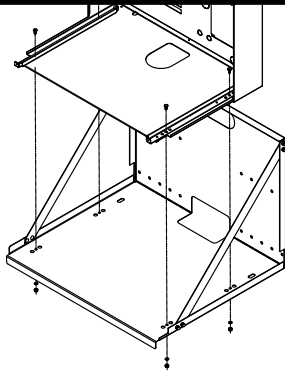

- Mount docking assembly to wall bracket accessory

**Machine stand accessory**

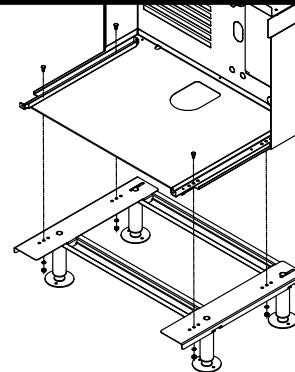

- Mount docking assembly to machine stand accessory

**4.1 Undercounter installation requirements Horizon 1010 & 1410 series**

**DOCKING STATION**

- Position and screw docking assembly to the bottom of counter inside of access panel/door ❶  
1010/1410: 2.25" (57 mm) from the front edge of assembly  
710: 3.25" (82.55 mm) from the front edge of the cross brace
- The mounting surface for the docking assembly must be solid. Do not mount directly onto runners or channels.
- There must be no lip or edge that would hinder the ice machine from sliding in or out of the docking station ❷

**INTAKE AND EXHAUST GRILLE PLACEMENT: Air-cooled models only**

- Position the intake grille cut out in the access panel/door  
**Note:** Ice machine must be aligned with cut out and inside of access panel to provide a tight seal and prevent recirculation of hot exhaust air.
- Left edge of cutout from the left side of the ice machine ❸  
1010/1410: 2.25" (57 mm)  
710: 2" (51 mm)
- Bottom edge of cutout should be 2" (51 mm) from the bottom of the ice machine ❹
- Position supplied exhaust grille at least 18" (458mm) away from intake grille ❺.  
Where possible, install exhaust grille to the rear or side of the base cabinet.
- If not using supplied grille, air circulation requirements below must be met:  
1010/1410: 250 sq. in (1613 sq cm) intake/exhaust air  
710: 160 sq. in (1032 sq cm) intake/exhaust air

## Undercounter installation detail

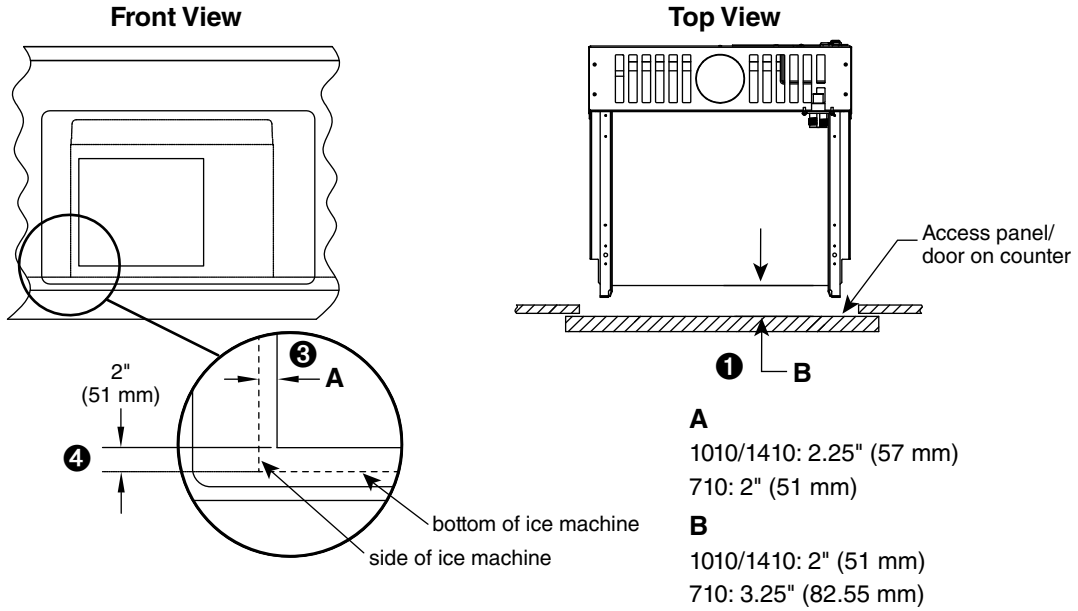

### ⚠ CAUTION

- Keep ventilation openings in the appliance enclosure clear of obstruction. Failure to do so could result in damage to equipment.
- To ensure proper ventilation (if not using supplied grille) carefully review air circulation specifications on previous page (4.1)

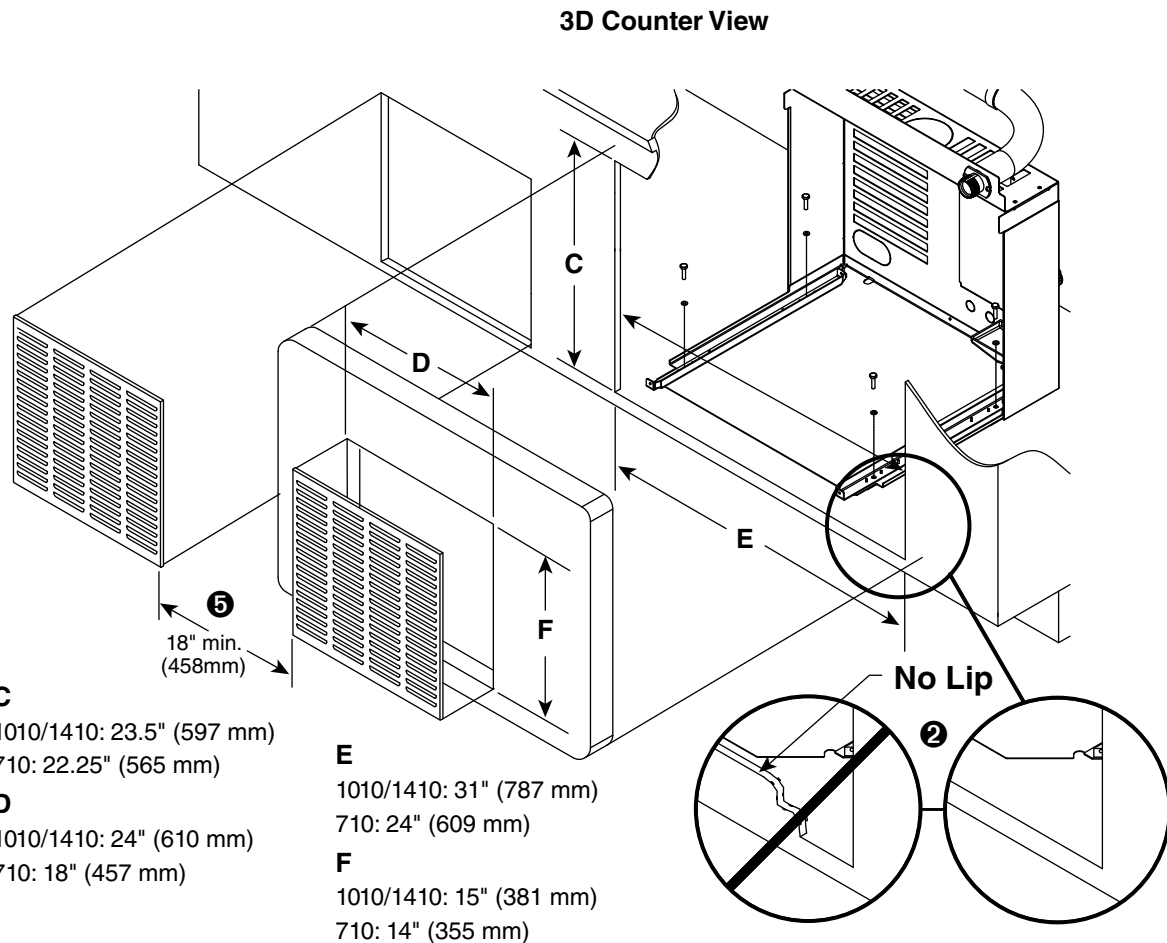

Install the ice transport tube.



### 5.1 Ice transport tube installation.

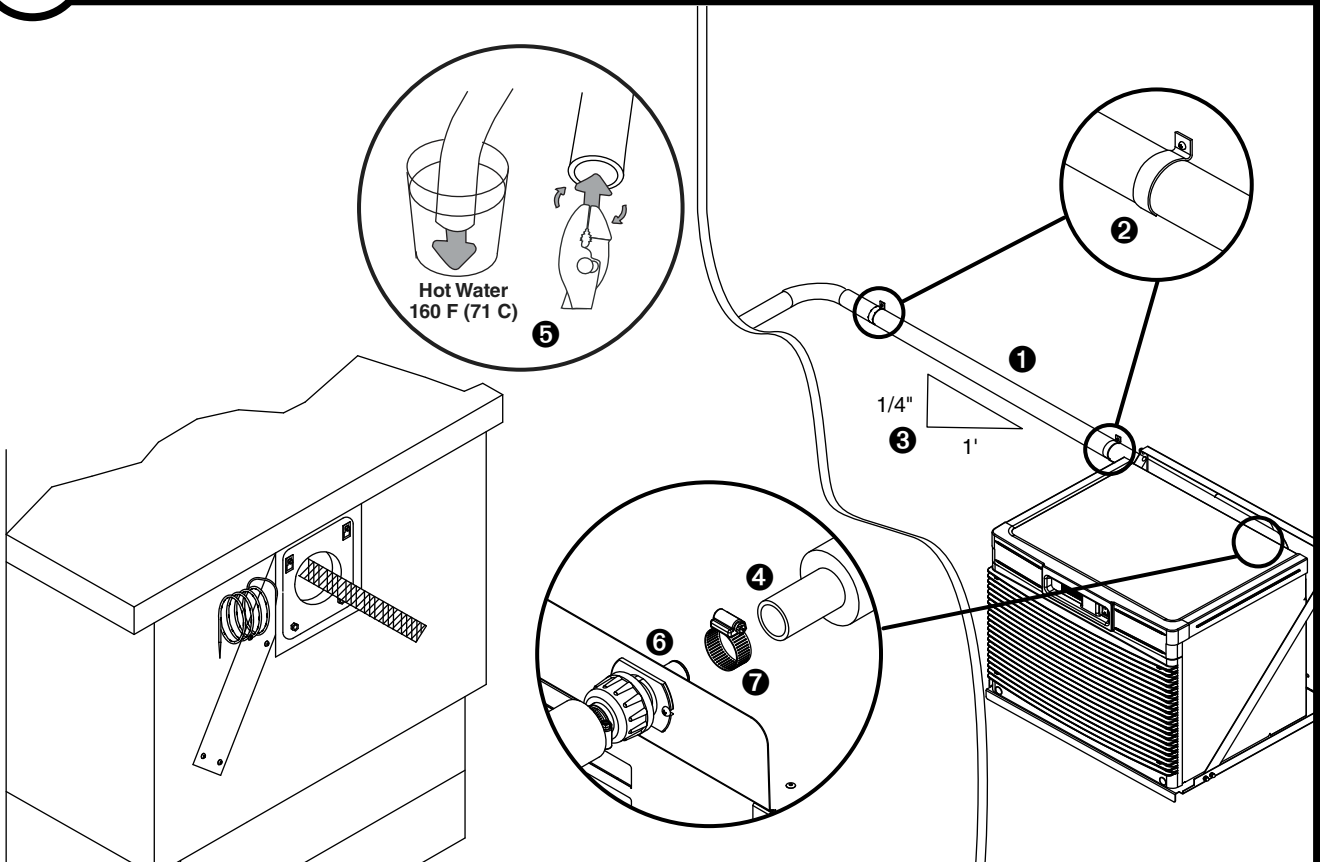

#### Ice transport tube tips

- Insulate entire length of ice transport tube ①
- Secure ice transport tube ② as needed to prevent dips and traps from forming. For long tube runs see guide on page 16.
- Pitch tube at least 1/4" per foot (6,4mm/.3m) ③
- Ice transport tube must drain towards ice machine

#### Ice transport tube to Ice machine

- Be sure tube ends are square ④
- Heat end of transport tube in cup of 160 F (71 C) hot water to soften and spread with pliers ⑤ before making connection to ease assembly
- Push ice transport tube onto ice machine nipple ⑥
- Install hose clamp ⑦



### 6.1 Bin Signal Installation

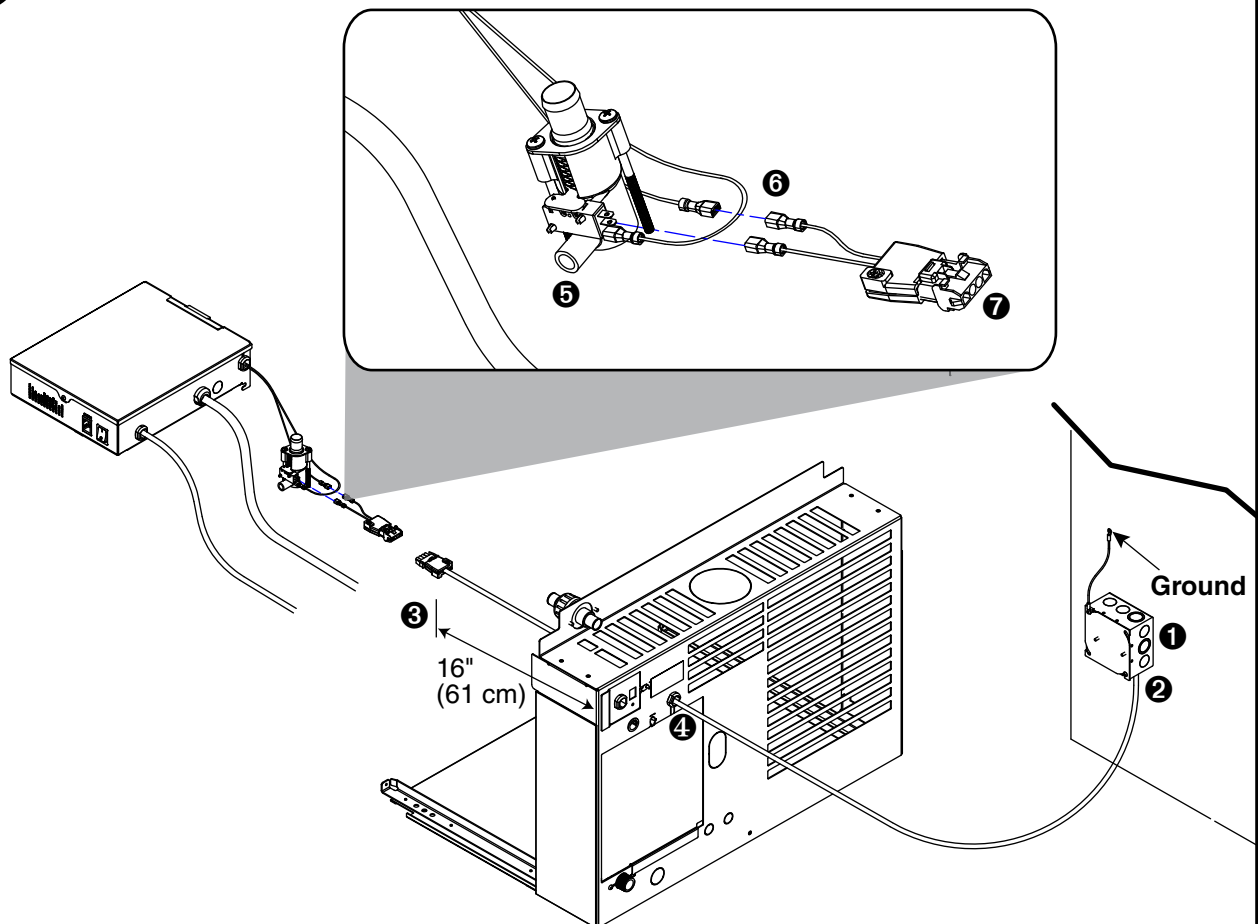

- Mount the electrical box to the side of the dispenser **1** to establish a ground connection.  
**Note:** If a 4 x 4 box is mounted to a non-grounded surface, connect ground wire at an appropriate ground.
- Connect the bin signal cord to the plug on the electrical box. **2**
- Insert 16" (61 cm) of the long bin signal cable **3** into the hole in the back of the docking station **4** and secure in place with strain relief provided.
- After sliding the ice machine module into the docking station, disconnect one wire from shuttle switch and replace with wire from adapter plug. **5**
- Connect wire removed from shuttle switch to male connector on adapter plug wire. **6**
- Complete normal installation procedure for the ice machine using the installation manual that shipped with the ice machine.
- Connect adapter plug into bin signal plug. **7**

Connect utilities to docking assembly.

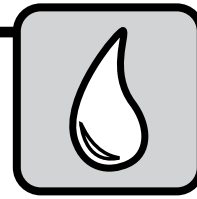

7.1 Air-cooled ice machines only

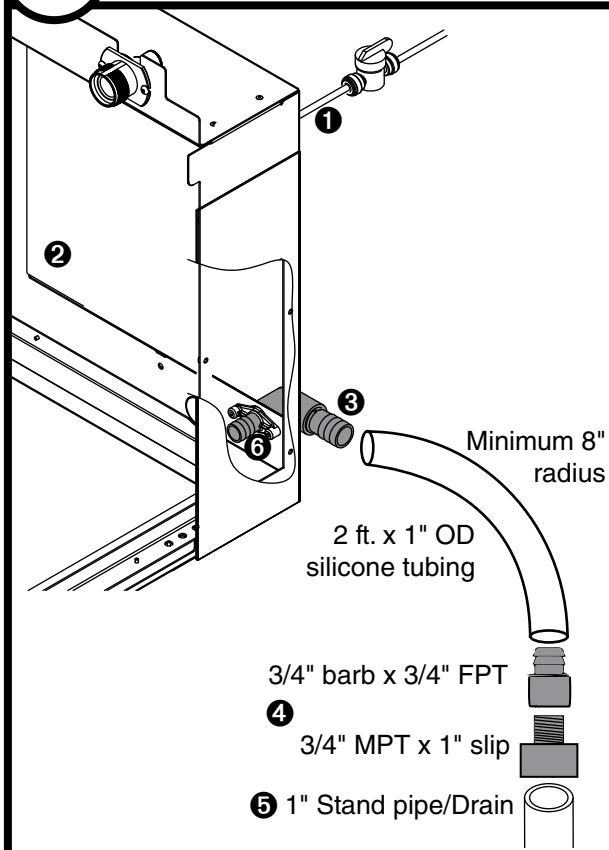

- Rough-in ice machine potable water supply ①. 3/8" push-in connection will be made at included shut-off valve then at back of docking station into solenoid.
  - Remove access panel if necessary ②.
  - Connect the silicone tubing to the ice machine 3/4" drain barb ③.
  - Assemble the 3/4" barb x 3/4" FPT to the 3/4" MPT x 1" slip. Connect the other end of the silicone tubing to the 3/4" barb ④.
  - Connect the 1" slip fitting to the 1" stand pipe/drain ⑤.
- Note:** Minimum 8" radius on silicone drain line. Drain line from the ice machine must have at least 1/4" per foot pitch (6,4 mm/0,3 m).
- Apply Petrol-gel to barbed drain fitting ⑥
  - Replace access panel.

7.2 Water-cooled ice machines only

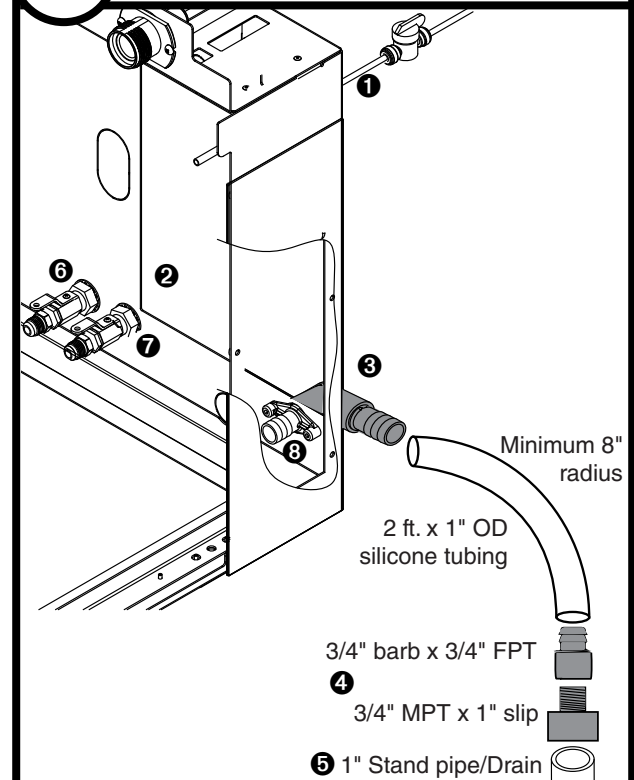

- Rough-in ice machine potable water supply ①. 3/8" push-in connection will be made at included shut-off valve then at back of docking station into solenoid.
  - Remove access panel if necessary ②.
  - Connect the silicone tubing to the ice machine 3/4" drain barb ③.
  - Assemble the 3/4" barb x 3/4" FPT to the 3/4" MPT x 1" slip. Connect the other end of the silicone tubing to the 3/4" barb ④.
  - Connect the 1" slip fitting to the 1" stand pipe/drain ⑤.
- Note:** Minimum 8" radius on silicone drain line. Drain line from the ice machine must have at least 1/4" per foot pitch (6,4 mm/0,3 m).
- Connect cooling water supply ⑥ and return ⑦
  - Apply Petrol-gel to barbed drain fitting ⑧
  - Replace access panel.

### Chassis drain plumbing - required

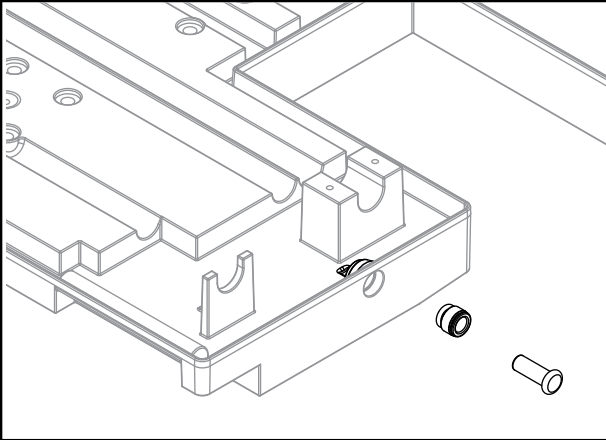

- Plug must be removed from John Guest fitting.
- Route 3/8" drain tubing through knockout in back of docking station and insert fully into John Guest fitting connection at the rear of the machine chassis. Route other end of 3/8" drain tubing to drain.
- Drain must slope 1/4" inch per foot (6 mm per 30,4 cm).

Connect docking assembly to ice machine.

**CAUTION**

- Plug must be accessible after final installation.

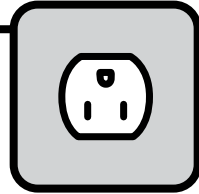

Air-cooled ice machines – follow steps 8.1 through 8.5.

**8.1 Ice transport tube**

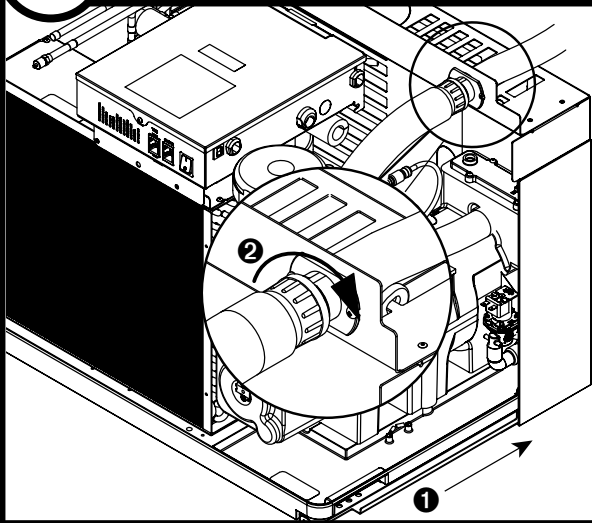

- Slide ice machine into docking assembly ensuring that drain tube is fully seated on barbed drain fitting **1**
- Insert ice transport tube all the way into coupling and tighten nut firmly **2**

**8.2 Water solenoid, shut-off valve, and potable water line options**

If water solenoid is already mounted to evaporator:

- Insert potable water line into shut-off valve.

If this is an undercounter installation:

- Mount water solenoid atop evaporator and locate the shut-off valve *inside* the machine. Insert potable water line into shut-off valve.

If water solenoid is not mounted and machine will not be installed under-counter:

- Mount water solenoid to inside rear (upper right corner) of docking assembly using one screw.
- Insert potable water line into shut-off valve - locate the shut-off valve *outside* the machine.
- Insert outgoing line from shut-off valve into push-in connection of water solenoid.

**8.3 Power cord**

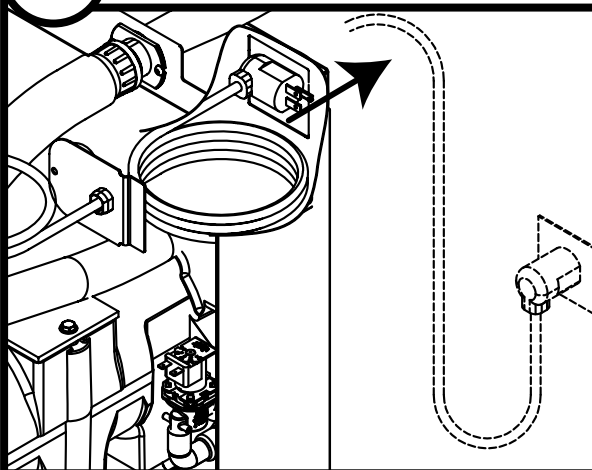

- Remove twist tie
- Carefully pass cord through opening and plug into wall outlet
- For H\_E units, install a suitable plug

**8.4 Power cord**

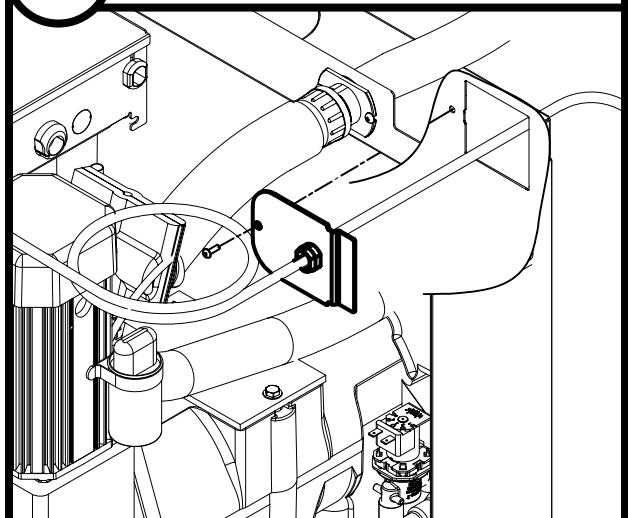

- Position plate into opening and secure with supplied screw

Water-cooled ice machines – follow steps 8.6 through 8.12.

### 8.5 TDS switch

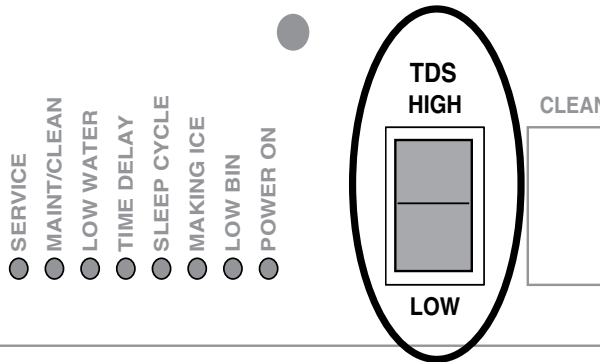

- Set the TDS switch on the electrical box:  
**HIGH:** for extended service life  
**LOW:** for low-scale water

### 8.6 Cooling lines

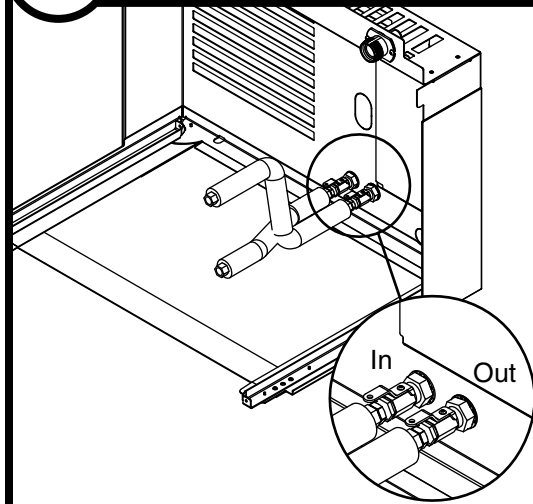

- Install ice machine cooling water lines to docking assembly

### 8.7 Ice transport tube

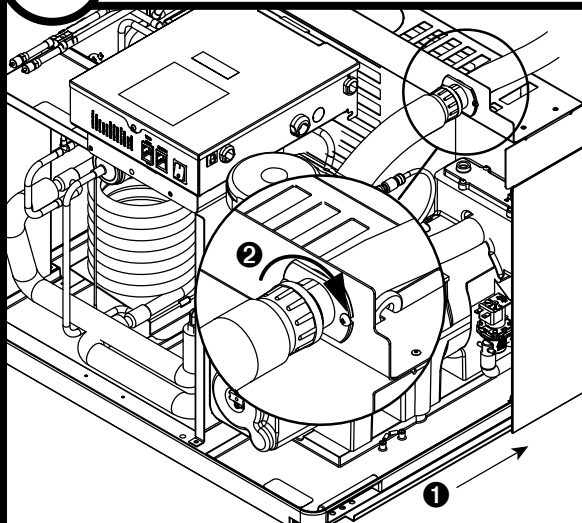

- Slide ice machine into docking assembly ensuring that drain tube is fully seated on barbed drain fitting ①
- Insert ice transport tube into coupling and tighten nut firmly ②

### 8.8 Water solenoid, shut-off valve, and potable water line options

**If water solenoid is already mounted to evaporator:**

- Insert potable water line into shut-off valve.

**If this is an undercounter installation:**

- Mount water solenoid atop evaporator and locate the shut-off valve *inside* the machine. Insert potable water line into shut-off valve.

**If water solenoid is not mounted and machine will not be installed under-counter:**

- Mount water solenoid to inside rear (upper right corner) of docking assembly using one screw.
- Insert potable water line into shut-off valve - locate the shut-off valve *outside* the machine.
- Insert outgoing line from shut-off valve into push-in connection of water solenoid.



### 8.9 Cooling lines and power

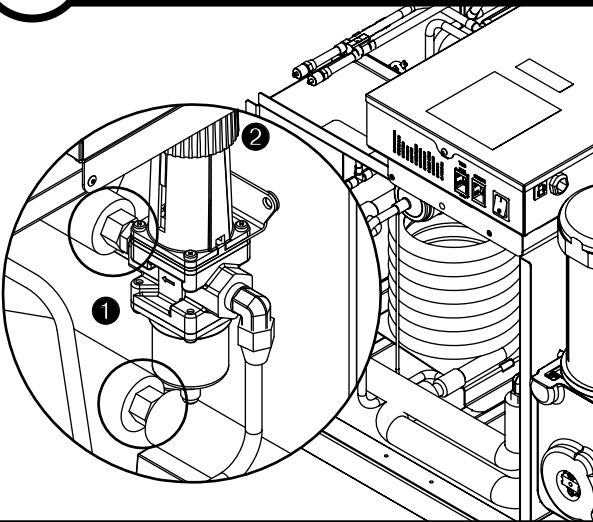

- Connect cooling water lines to ice machine ①
- Water valve is set at the factory. **DO NOT** remove seal or adjust water valve ②

### 8.10 Power cord

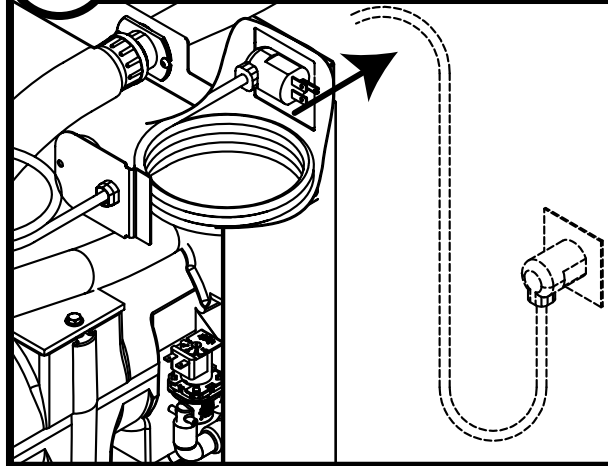

- Remove twist tie
- Carefully pass cord through opening and plug into wall outlet
- For H\_E units, install a suitable plug

### 8.11 Power cord

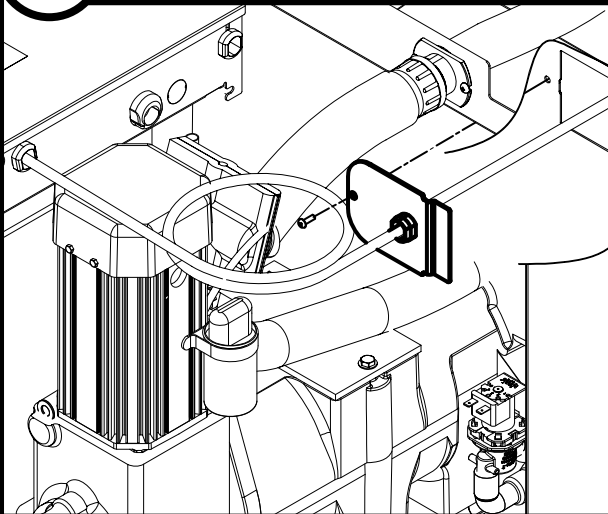

- Position plate into opening and secure with supplied screw

### 8.12 TDS switch

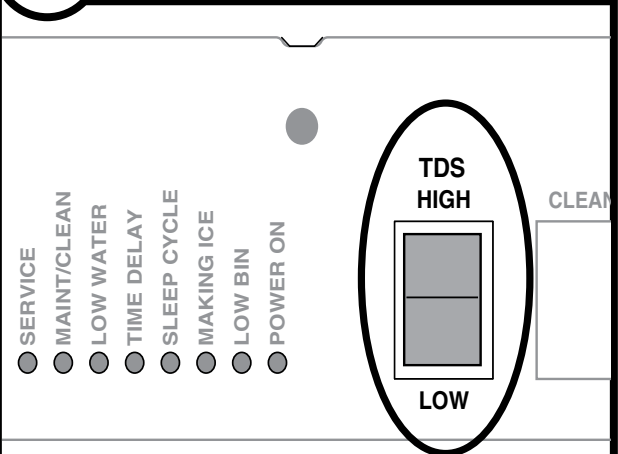

- Set the TDS switch on the electrical box:  
**HIGH:** for extended service life  
**LOW:** for low-scale water

### NOTICE

Ice machine **MUST** be sanitized prior to operation!  
Consult Operation and Service Manual provided with ice machine for sanitizing instructions.

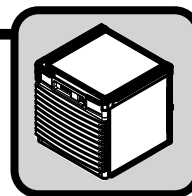

**Front cover installation –  
air-cooled undercounter only**

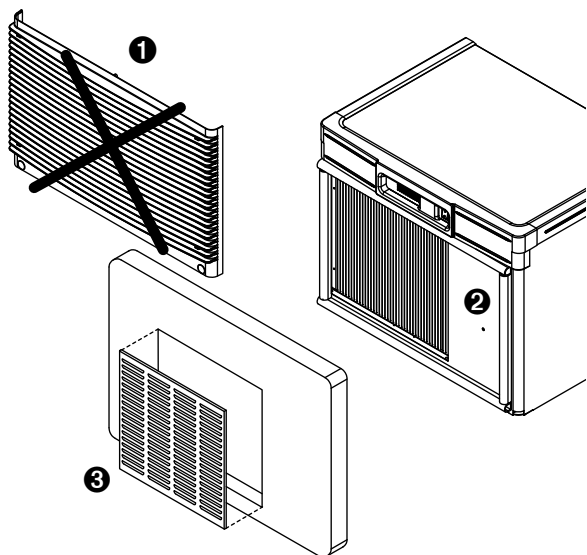

**CAUTION**

- Keep ventilation openings in the appliance enclosure clear of obstruction.
- To ensure proper ventilation (if not using supplied grille) carefully review air circulation specifications in section 4.1

- Remove and discard plastic grille **1**
- Apply supplied gasket material around entire opening on skin to prevent air recirculation **2**
- Attach supplied metal grille to opening in counter door (see section 4.1) **3**

**Install front cover**

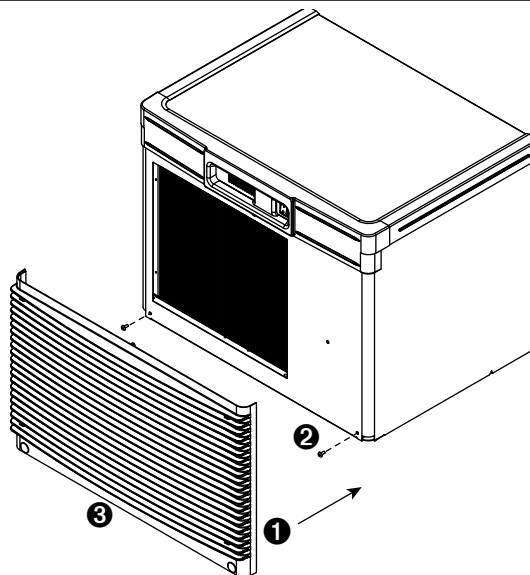

- Slide ice machine cover over machine ensuring that tabs on back of cover slip under louvers on back of docking assembly **1**
- Insert and tighten two screws through cover and into docking assembly **2**
- For air-cooled machines only, install plastic grill **3**

## Long tube run recommendations

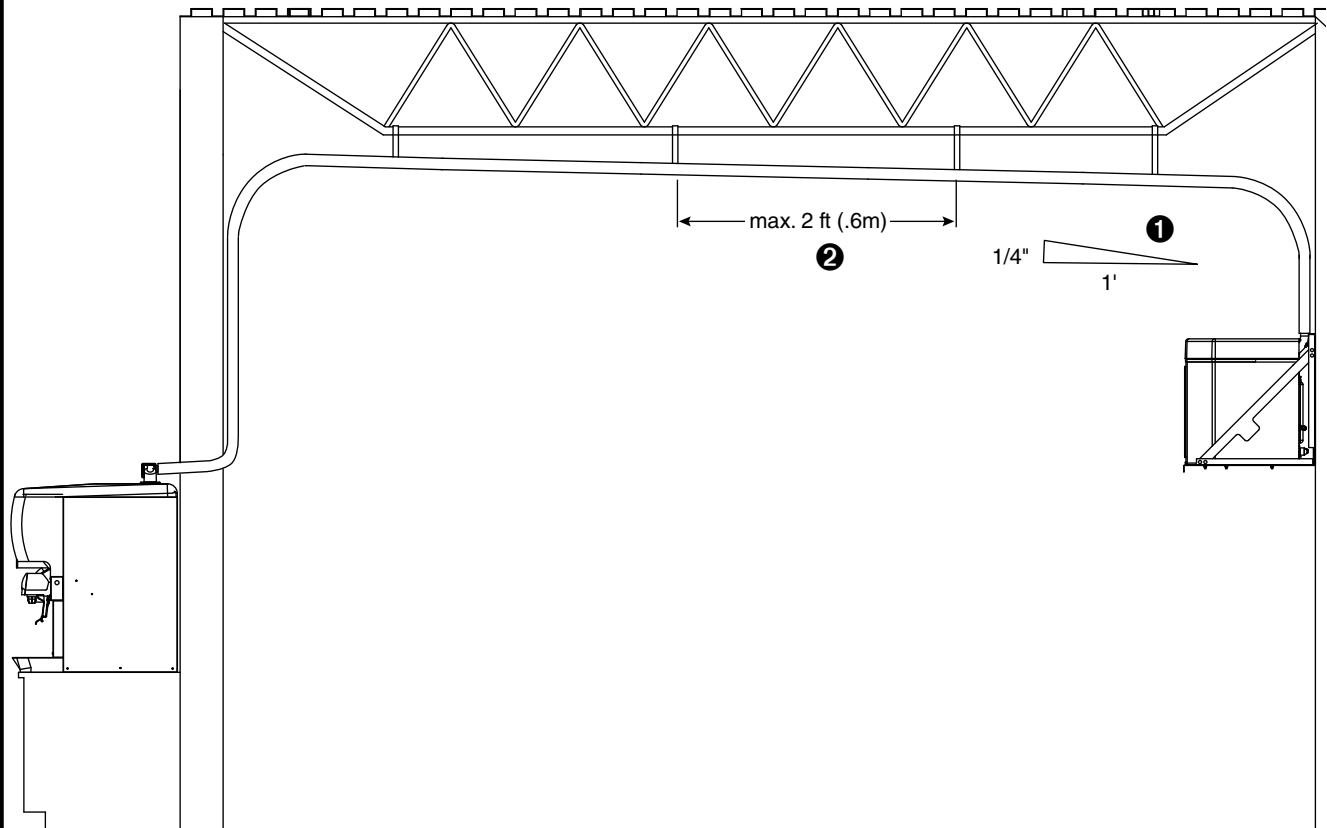

- Pitch ice transport tube to allow melt water to drain towards ice machine ①
- Secure insulated ice transport tube at least every 2 ft (.6m) to prevent dips or traps ②



801 Church Lane • Easton, PA 18040, USA  
Toll free (877) 612-5086 • +1 (610) 252-7301  
[www.follettice.com](http://www.follettice.com)

01113265R05  
© Follett Products LLC 2/22