

Keypad Lock

Order parts online
www.follettice.com

Operation and Service Manual



Table of contents

Overview	3
Reversing the door swing (optional)	3
Keypad operation	
General information about codes	4
To open door	4
Before you begin	4
Factory-set master code	4
Changing the master code	4
Working with user codes	5
To enter or change a user code	5
To delete a user code	5
Keypad wear	5
Battery changing instructions	
Low battery condition	6
Low battery simulator	6
Battery replacement	6
Troubleshooting guide	7
Keypad connector check	7
Replacement parts	back cover

Overview

Follett's keypad lock option provides additional security for refrigerator contents by providing up to eight user-programmable access codes and automatic relocking of door upon closure. Its advanced electronic circuit design ensures easy, quick opening, as well as easy addition and deletion of codes.

Upon entry of a correct code on the keypad, the slip bolt lock on the reverse of the door retracts from the latch mounted on the inside "ceiling" of the REF. This allows the door to be opened. The door automatically relocks upon closure.

Reversing the door swing – optional

Follett keypad-equipped refrigerators are shipped from the factory with a right hand door swing. If a left swing is desired, the latch, hinges and handle must be moved to the opposite side as described below. Please note that this procedure differs from the procedure required for standard REFs without keypad locking.

1. Remove screws and latch from refrigerator cabinet (Fig. 1.1).
2. Remove handle from door (Fig. 2.1).
3. Use flat screwdriver to carefully remove (do not scratch) hinge covers (Fig. 3.1).
4. Support door and remove screws attaching hinges to refrigerator cabinet (Fig. 3.2).
5. Remove screws attaching hinges to door.
6. Remove plugs on left face of door and reinstall hinges in these holes.
7. Remove plugs on left face of cabinet and reinstall hinges in these holes.
8. Remove plugs from right face of door and reinstall handle in these holes (application of 242 blue Loctite* to handle screws recommended).
9. Remove plugs from right face of cabinet and reinstall latch in these holes.
10. Use removed plugs to cover open holes.
11. Test door for proper closure
12. Readjust latch engagement if necessary, following instructions in service section of REF manual shipped with the unit.

Fig. 1

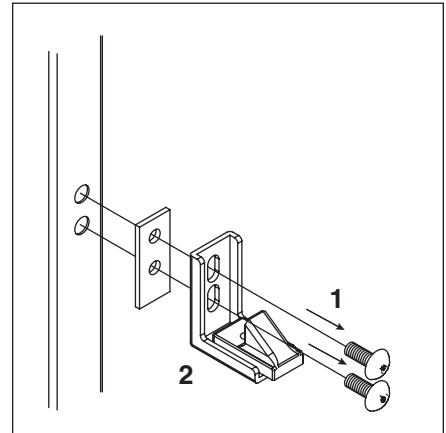

Fig. 2

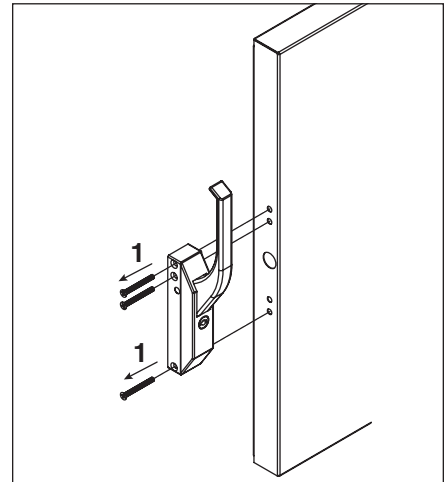
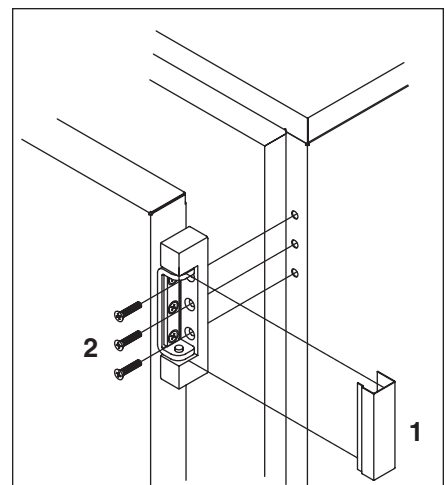

Fig. 3



Keypad Operation

General information about codes

- All codes contain six key entries followed by #.
- Each time a key is pressed and the lock accepts the input, the lock emits a “beep” and the LED on the keypad lights momentarily.
- If you pause more than 10 seconds between pressing any key, the lock assumes you do not want to continue and resets itself to the original code. To open the lock, begin the code entry sequence again.
- If you press an incorrect key when entering a code, press * or simply pause ten seconds or more. Then enter the correct code.
- If four incorrect codes are entered in a row, the lock shuts down for 5 minutes as a security feature. Pressing any key during the lockout period resets the timer to a 5-minute delay. Do NOT touch any keys for 5 minutes, then enter a valid code to open the lock.
- If a long series of closely spaced beeps (almost a continuous tone) sounds when # is pressed, the entry has not been accepted

To open door

1. Enter a valid six-digit code followed by the # key.
2. Wait 3 seconds for the bolt to retract.
3. Pull on the door handle to open.
4. Door will automatically relock on closure.

ALWAYS KEEP THE DOOR OPEN WHEN MAKING ANY CODE CHANGES.

Before you begin

DO NOT REMOVE THE WHITE LABEL ON THE LOCK MECHANISM!

This contains an important code that may assist the factory in troubleshooting problems.

Factory-set master code

- The keypad lock is shipped with a factory-set master code of 1 2 3 4 5 6 #.
- The master code will always open the lock and is used to set all user codes.
- For optimal security you may want to change the factory-set code to your own, unique master code.

REMEMBER YOUR MASTER CODE. If it is lost, you will not be able to change codes!

Changing the master code (code ID 1)

1. Press 74*.
2. Enter existing 6-digit master code, followed by # (hear 5 beeps).
3. Press 1* (1 = master code).
4. Enter new 6-digit master code, followed by # (hear 3 beeps).
5. Enter new 6-digit master code again, followed by # (hear 3 beeps).
6. Your new master code is entered.

Working with user codes (code IDs 2 - 9)

Keypad can be set to open on up to eight different user codes, designated by user ID numbers 2, 3, 4, 5, 6, 7, 8 and 9. User codes do not exist until they are programmed into the lock.

To enter or change a user code

1. Press 74*.
2. Enter master code, followed by # (hear 5 beeps).
3. Press ID number for the code you want to enter or change (2 – 9), followed by *.
4. Enter new 6-digit user code, followed by # (hear 3 beeps).
5. Enter new 6-digit user code again, followed by # (hear 3 beeps).
6. Your new user code is entered.

To delete a user code (code ID 2 - 9)

1. Press 74*.
2. Enter master code, followed by # (hear 5 beeps).
3. Press ID number for the code you want to delete (2 – 9), followed by *.
4. Press # (hear 3 beeps).
5. Press # again (hear 3 beeps).
6. The user code has been deleted.

Keypad wear

It is advisable to use as many different keys as possible in your codes to avoid uneven wear. Check the keypad occasionally for excessive key wear and change codes to avoid worn keys, if possible. If keys become excessively worn, you may need to purchase a new keypad.

Battery Changing Instructions

Low battery condition

Two 9-volt batteries power the keypad lock. A low battery condition is signaled by a change in the tone of the beep when keys are pushed. This provides advance warning that the batteries are in need of replacement.

If the keypad emits 20 consecutive beeps after the # key is pressed during code entry, the batteries are too low to power the lock and must be replaced before the lock can be opened.

Low battery simulator

A low battery simulator can be used to hear the tone change that signals a low battery condition.

1. Depress the * key for about 3 seconds until 3 beeps are heard.
2. Enter a valid code and note that the sound of the beep following each key entry is distinctly different from the sound heard in normal operation.
3. Keypad will automatically revert to normal operation in about 2 seconds.

Battery replacement

Note: Codes will NOT be lost during battery change.

1. Grip keypad at bottom (Fig. 4.1) and pull bottom of keypad housing away from mounting base (Fig. 4.2).
2. Support keypad housing to avoid stressing or pulling on wires attached to circuit board. Do NOT let keypad hang from wires.
3. Remove batteries from keypad back (Fig. 5)
4. Install new batteries, being careful to avoid bending connectors or reversing polarity.
5. Hold keypad housing close to mounting base and accordion-fold excess cable wire inside housing (Fig. 6), being careful to position wire away from spring clips holding keypad housing to mounting base.
6. Align spring clips with receptacles in base.
7. Use steady pressure to push keypad housing back onto base. Do NOT allow wires to be damaged by contact with clips.
8. Check master code and all user codes at least 3 times with door open.
9. Close door only after lock has been thoroughly tested for proper operation.

Fig. 4

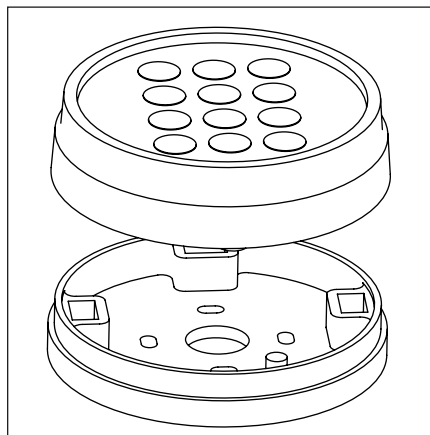

Fig. 5

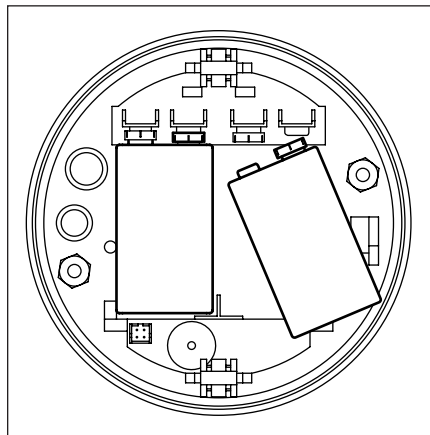
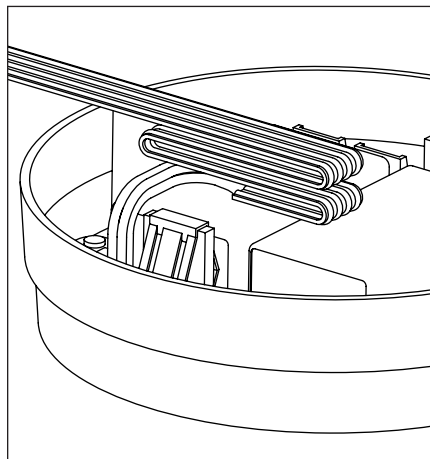

Fig. 6



Troubleshooting Guide

Problem	Possible Cause	Solution
Keypad beeps and LED flashes on key press but lock does not open	# key was not entered after code	Press # key after entering code
	Wrong code is used	Use correct access code
	Batteries need replacement	Replace batteries
	Lock is in security lockout mode	Wait 5 minutes and retry
	Lock bolt is binding	Push in on door while entering code; remove source of binding or adjust bracket
	Keypad is defective	Replace keypad
Lock opens but doesn't beep or light when key is pressed	Sounder or LED is defective	Replace keypad
Lock will not allow programming	Incorrect Master Code	Use correct Master Code
Lock can be heard starting but door does not open	Batteries are weak	Replace batteries
Lock opens but bolt does not relock door	Batteries are weak	Replace batteries
Lock opens intermittently when using valid codes	Loose wire connection to keypad	Perform keypad connector check below.
	Keypad is defective	Replace keypad
Lock motor runs continuously after battery change. Lock stays locked.	Logic circuit did not reset properly when power restored to logic circuits.	Unplug wire connector from keypad back. Leave unplugged for 40 seconds and reinstall. (See Keypad Connector Check below.)

Keypad connector check

1. Unplug wire connector from circuit board inside keypad housing.
2. Check for loose wires at 4-wire connector.
3. Inspect each wire by pushing and rotating where it enters connector.
4. If motion is noted, push in on wire to tighten.
5. To reinstall connector, align ridge on connector with slot in receptacle and plug connector into receptacle. Connector only fits one way. If connector does not slide easily into place, do not force. Turn connector 180° before attempting to insert it again.
6. Operate lock with valid code.
7. If looseness still present, replace lock mechanism.

Fig. 7

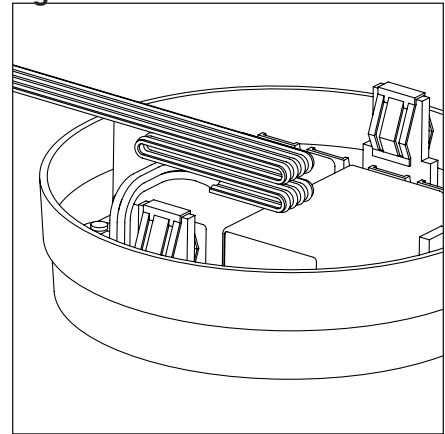
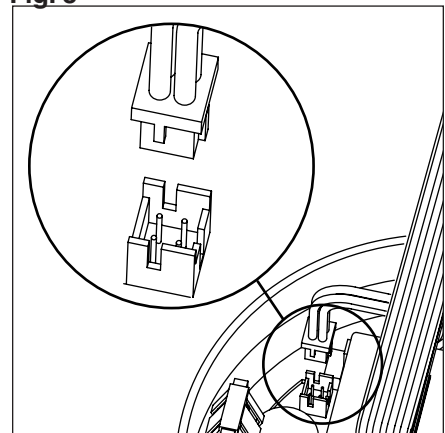

Fig. 8



Replacement Parts

Description	Part #
Latch, door	00158154
Lock mechanism, spring-bolt	00160093
Keypad housing and mounting base	00160101
Battery, 9-volt	00112177
Plug, chrome	00105536
Keypad-ready door, REF4-ADA (no keypad or lock mechanism)	00162248
7Keypad-ready door, REF5 (no keypad or lock mechanism)	00162230