

Ice and Water Dispensers

25CI400A/W, 25HI400A, 50CI400A/W, 50HI400A

Order parts online
www.follettice.com

Installation, Operation and Service Manual

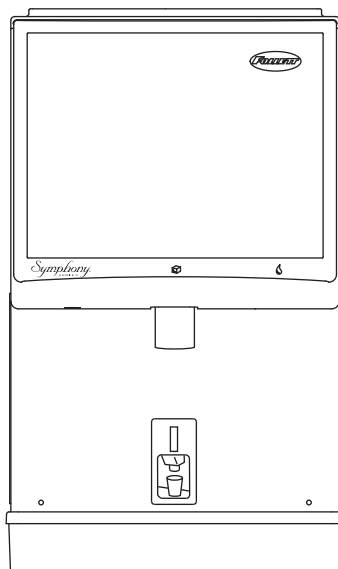

25/50CI400A/W-SI Countertop
Ice-only Dispenser with
SensorSAFE™ Dispensing

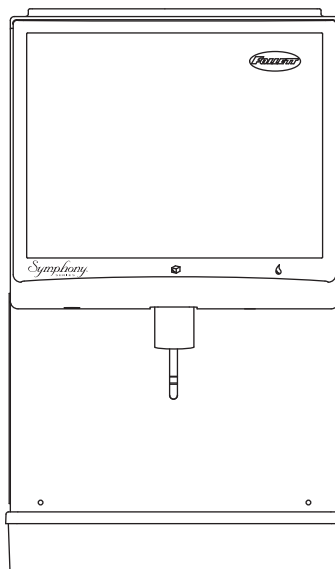

25/50CI400A/W-LI Countertop Ice-only
Dispenser with Lever Dispensing

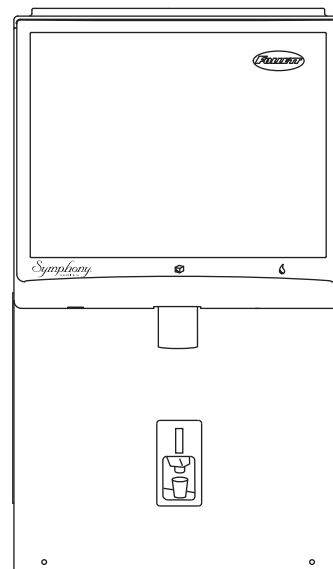

25/50HI400A-SI Wall Mount
Ice-only Dispenser with
SensorSAFE Dispensing

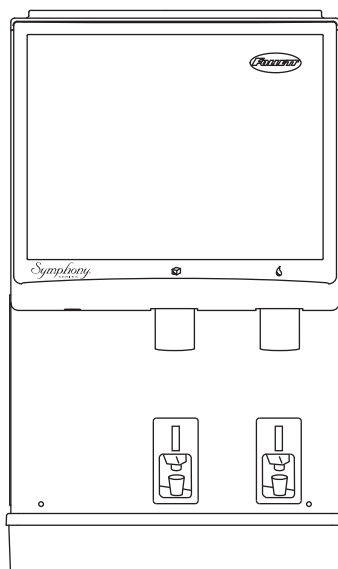

25/50CI400A/W-S Countertop Dispenser
with SensorSAFE™ Dispensing

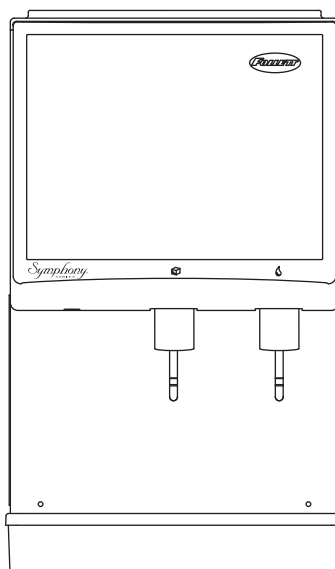

25/50CI400A/W-L Countertop Dispenser
with Lever Dispensing

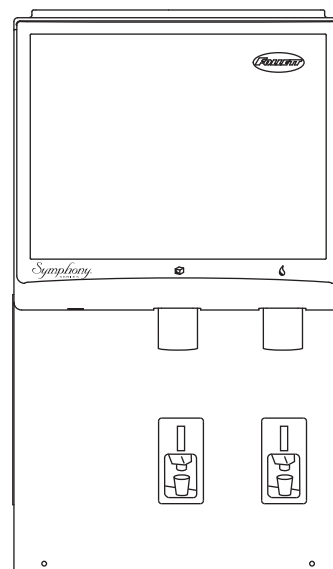

25/50HI400A-S Wall Mount Dispenser
with SensorSAFE Dispensing

**Following installation, please forward this manual
to the appropriate operations person.**

Contents

Welcome to Follett	3	Diagnostic sequence – Stage 7	27
Before you begin	3	Diagnostic sequence – Stage 8	27
Contact Information	3	Diagnostic sequence – Stage 9	28
Specifications	4	Diagnostic sequence – Stage 10	28
Electrical	5	Refrigeration cycle	29
Ambient	5	Refrigeration data	30
Plumbing	5	Ice production	30
Ventilation and service clearances	5	Ice capacity test	30
Uncrated weight	5	Compressor current draw	30
Installation	6	Gearmotor data	30
Before you begin	6	Refrigeration system	30
Installing countertop dispensers with rear exiting utilities (no legs)	6	Ice machine charge specifications	30
Installing countertop dispensers with bottom exiting utilities	6	Refrigerant replacement requirements	30
Installing wall mount dispensers	8	Evacuation	30
Cleaning/descaling and sanitizing	10	Ambients	30
Weekly	10	Dispenser troubleshooting	31
Monthly	10	Before calling for service	31
Semi-Annually	11	Lever model troubleshooting guide	31
Service	14	SensorSAFE model troubleshooting guide	31
Ice machine operation	14	Board guide	31
The icemaking process	14	Lens/sensor troubleshooting	31
Ice harvest system diagram	14	Ice machine troubleshooting	32
Disassembly and replacement instructions	15	Dispenser replacement parts	34
Dispense wheel removal and installation	15	Dispenser exterior	34
Drive bar removal	15	Dispense chute and splash panel areas (lever models) – Serial Number D61292 and above	35
Wheel motor assembly removal	15	Dispense chute and splash panel areas (lever models) – Serial Numbers below D61292	36
Ice transport tube replacement	15	Dispenser electrical box – lever models	37
Ice machine removal	16	Dispense chute and splash panel areas (SensorSAFE models) Serial Number D61292 and above	38
Evaporator disassembly	18	Dispense chute and splash panel areas (SensorSAFE models) – Serial Numbers below D61292	39
Evaporator reassembly	19	Dispenser electrical box – SensorSAFE models	40
Gearmotor replacement	19	Wheel motor and drive system	41
Fan removal	19	Water and drain	42
Electrical systems	20	Ice machine replacement parts	43
Electrical component locations	20	Evaporator	43
Wiring diagram - lever dispense model	21	Air-cooled ice machines	44
Wiring diagram - SensorSAFE model	22	Water-cooled ice machines	46
Ice machine operational and diagnostic sequences	23	Ice machine electrical components	48
Circuitry notes	23	Water treatment accessories for Symphony ice and water dispensers	49
Normal operation – Stage 1	24		
Normal operation – Stage 2	24		
Normal operation – Stage 3	25		
Normal operation – Stage 4	25		
Normal operation – Stage 5	26		
Normal operation – Stage 6	26		

Welcome to Follett

Follett equipment enjoys a well-deserved reputation for excellent performance, long-term reliability and outstanding after-the-sale support. To ensure that this equipment delivers that same degree of service, we ask that you take a moment to review the installation portion of this manual before beginning to install the unit. Our installation instructions are designed to help you achieve a trouble-free installation. Should you have any questions or require technical help at any point, please call our technical service group at (877) 612-5086 or +1 (610) 252-7301.

Note: To expedite assistance, all correspondence or communication **MUST** include the model number, serial number and complete and detailed explanation of the problem

Before you begin

After uncrating and removing all packing material, inspect the equipment for concealed shipping damage. If damage is found, notify the shipper immediately and contact Follett Corporation so that we can help in the filing of a claim, if necessary.

Check your paperwork to determine which model you have. Follett model numbers are designed to provide information about the type and capacity of Follett ice dispensing equipment. Following is an explanation of the different model numbers.

IMPORTANT
<ul style="list-style-type: none">• Only qualified technicians should attempt to service or maintain this ice and water dispenser• No service or maintenance should be undertaken until the technician has thoroughly read this service manual

Contact Information

FOLLETT CORPORATION, 801 Church Lane, Easton, PA 18040 USA
Phone: toll free (877) 612-5086 or +1 (610) 252-7301
Web site: www.follettice.com

25CI400A-LI

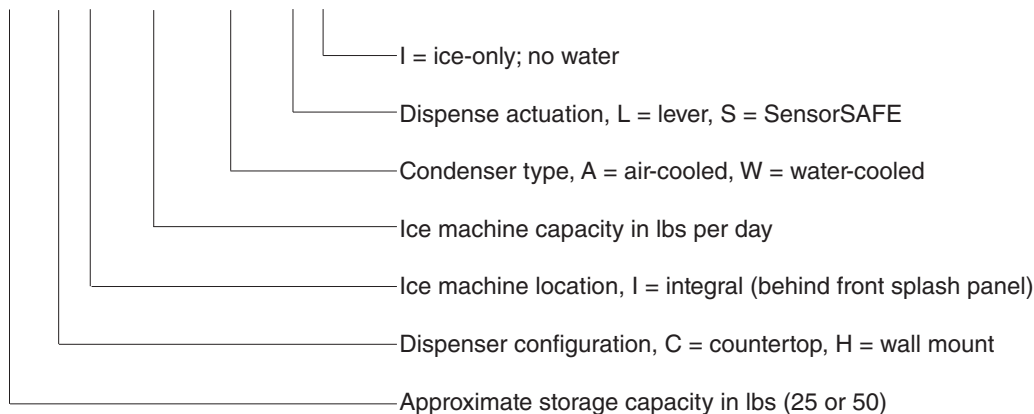

⚠ CAUTION
<ul style="list-style-type: none">• Do not tilt any unit further than 30° off vertical during uncrating or installation• Dispenser bin area contains mechanical, moving parts. Keep hands and arms clear of this area at all times. If access to this area is required, power to unit must be disconnected first.• Ice is slippery. Be sure counters and floors around dispenser are clean, dry and free of ice.• Do not block left side air intake or right side air exhaust

IMPORTANT NOTICE
<ul style="list-style-type: none">• Follett recommends a Follett water filter system be installed in the ice machine inlet water line (standard capacity #00130299, high capacity #00978957, carbonless high capacity #01050442).• Prior to operation clean and sanitize the dispenser in accordance with instructions found in this manual.

Specifications

Countertop

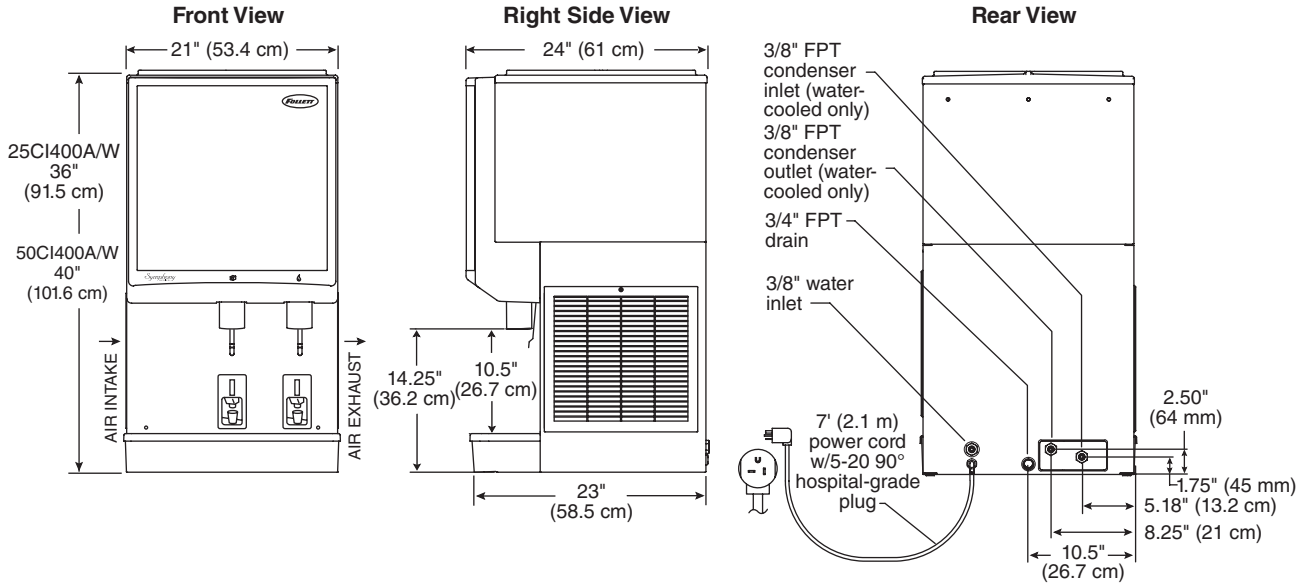

Wall mount

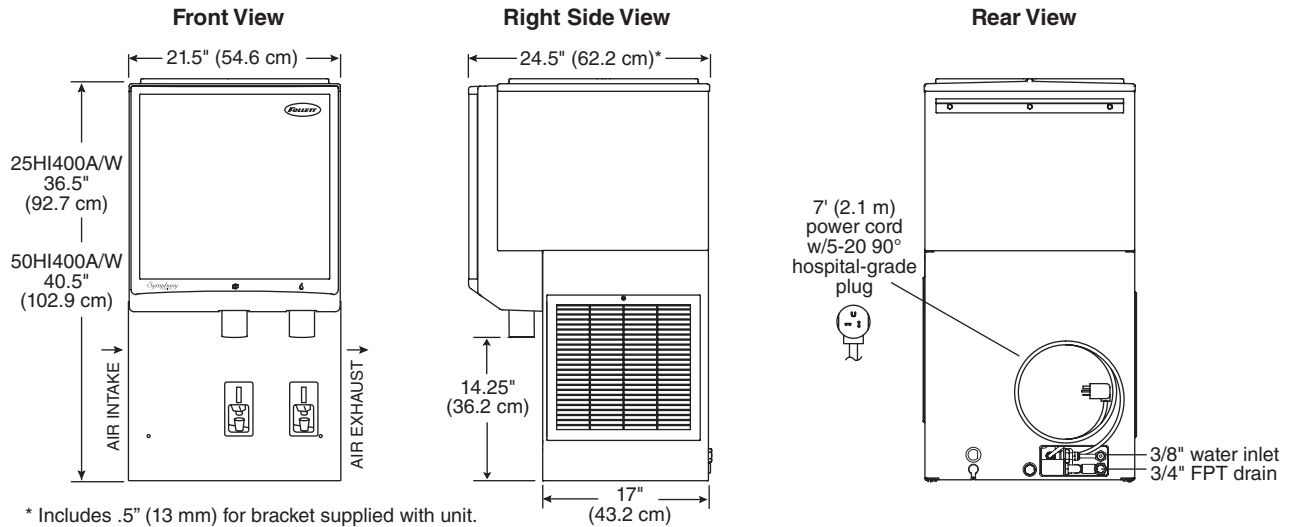

Electrical

115 V, 60 Hz, 1 phase, 14.0A. Connect to dedicated 20A circuit, fuse or breaker.

Note: It is preferred that circuit be protected by a GFCI.

Furnished with 7 ft (2 m) power cord with a 90° NEMA hospital grade 5-20 plug.

Ambient

	Maximum	Minimum
Air temp	100 F/38 C (Best performance below 80 F/27 C)	50 F/10 C
Water temp	90 F/32 C (Best performance below 70 F/21 C)	40 F/4 C
Water pressure	70 psi (483 kpa)	10 psi (69 kpa)

Plumbing

	Connections – 25/50CI400A/W	Rough-ins – 25/50HI400A/
Dispenser drain	All – 3/4" FNPT	Air-cooled – 3/4" FNPT
Water inlet	All – 3/8" FNPT	All – 1/2" FNPT
Condenser inlet	Water-cooled – 3/8" FNPT	N/A
Condenser outlet	Water-cooled – 3/8" FNPT	N/A

Note: Water shut-off recommended within 10' (3 m) of dispenser. Drain to be hard-piped and insulated. Maintain at least 1/4" per foot (20 mm per 1 m run) of slope on horizontal runs.



CAUTION

- Do not block left side air intake or right side air exhaust

Ventilation and service clearances

	Air-cooled	Water-cooled
Required for ventilation	3" (77 mm) each side	N/A
Suggested for service	12" (30.5 cm) top, 6" (15.3 cm) left side	12" (30.5 cm) top

Uncrated weight

25/50CI400A/W (countertop) 215 lbs (98 kg)
25/50HI400A (wall mount) 230 lbs (105 kg)

Installation

Before you begin

Level dispenser in both directions to ensure proper operation.

Provide clearances noted in clearances table on page 5.

Countertop models provide the option of taking utilities out bottom or back of dispenser.

Wall mount model utilities exit through back of dispenser only.

Directions for each installation follow.

WARNING	
	<ul style="list-style-type: none"> • DO NOT LIFT UNIT AT THESE POINTS. Panels will not support weight of unit • Failure to follow warning may result in equipment damage or personal injury

Installing countertop dispensers with rear exiting utilities (no legs)

Fig. 1
Countertop anchoring locations

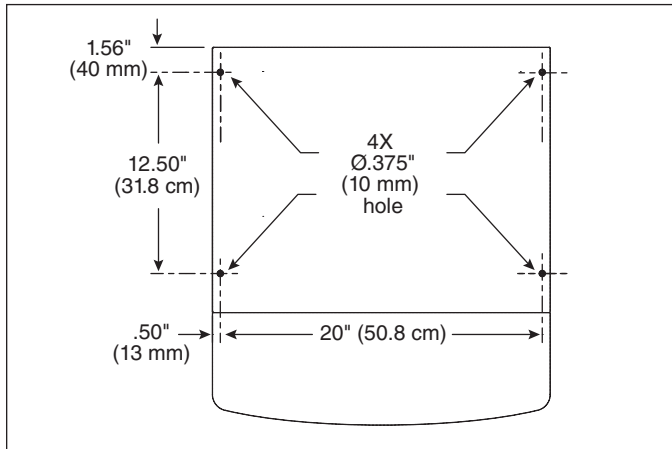

1. Position dispenser in desired location.
2. Mark dispenser outline on counter and remove dispenser.
3. Drill four 7/16" holes in counter to anchor dispenser to counter (Fig. 1).
4. Apply a thick bead approximately 1/4" (7 mm) diameter of NSF listed silicone sealant (Dow Corning* RTV-732 or equivalent) 1/4" (7 mm) inside marked outline of dispenser.
5. Reposition dispenser on counter and secure to counter with four 3/8"-16NC bolts.
6. Smooth excess sealant around outside of dispenser.

* Dow Corning is a register trademark of Dow Corning Corporation in the United States and other countries

Fig. 2
Utility connections as viewed from top for countertop back access

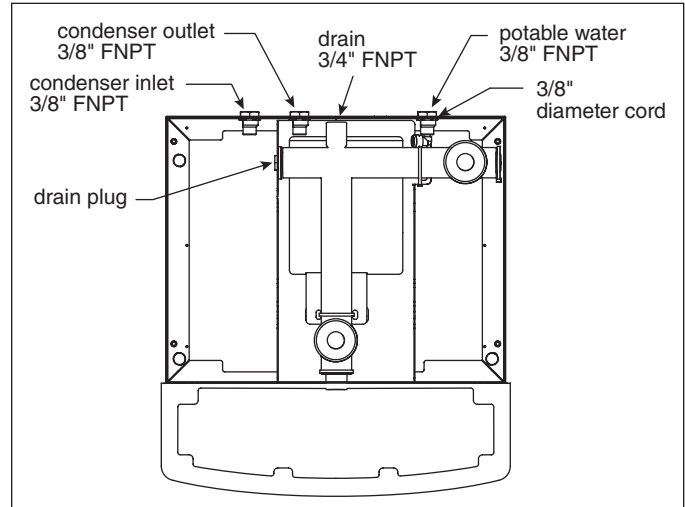

7. Make utility connections (Fig. 2).

CAUTION	
<ul style="list-style-type: none"> • Do not connect water-cooled condenser outlet line to the dispenser drain line. 	

8. Turn on water supply and check for leaks.
9. Clean and sanitize dispenser and ice machine before putting into service.
10. Turn power on and allow ice machine to produce ice.

Installing countertop dispensers with bottom exiting utilities

WARNING	
<ul style="list-style-type: none"> • A sturdy work surface capable of supporting the entire dispenser must be used • The work surface must be large enough to accommodate height of dispenser • Failure to provide proper support may result in personal injury 	

Fig. 3

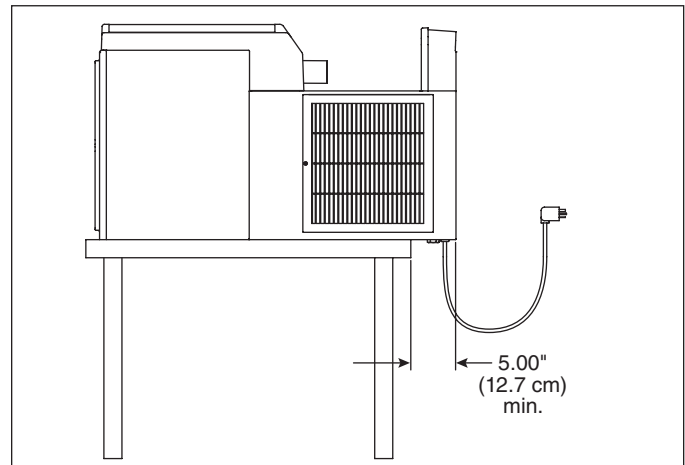

1. Position dispenser with dispense chutes facing upward on sturdy work surface (Fig. 3).

Fig. 4

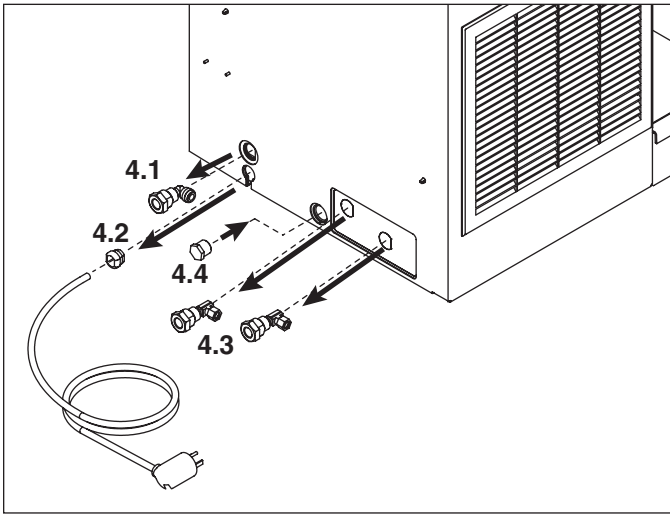
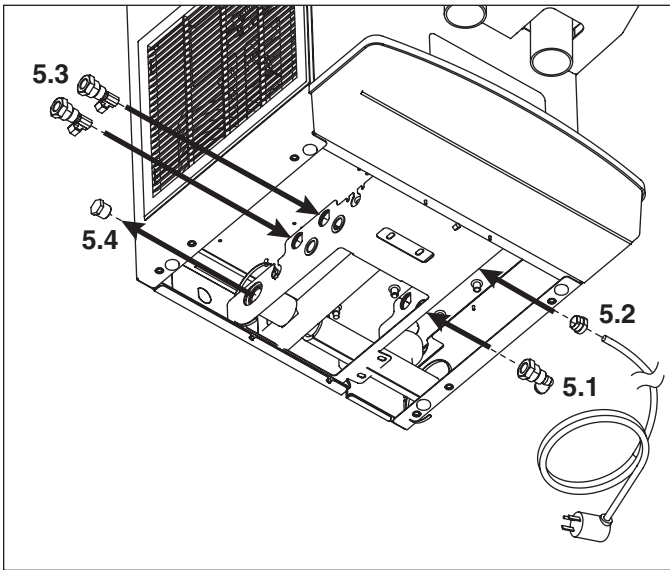

Fig. 5



2. Disconnect the internal water line from the potable water connection fitting.
3. Remove fitting from the back wall of the dispenser (Fig. 4.1).
4. Relocate fitting to internal bulkhead and reconnect (Fig. 5.1).
6. Remove power cord strain relief (Fig. 4.2).
7. Relocate the cord and strain relief to the internal bulkhead and reconnect (Fig. 5.2).
8. **Water-cooled only.** Disconnect internal condenser water inlet and outlet fittings (Fig. 4.3).
9. **Water-cooled only.** Relocate water inlet and outlet fittings and reconnect (Fig. 5.3). **Note:** The water inlet is connected to the condenser; the outlet line is connected to the water regulating valve.
10. Remove the drain plug from the internal drain line connection point (Fig. 5.4).
11. Relocate to back of dispenser and reconnect (Fig. 4.4).

12. Raise the dispenser upright and position in desired location.
13. Mark dispenser outline on counter and remove dispenser.

Fig. 6
Countertop cutout viewed from top

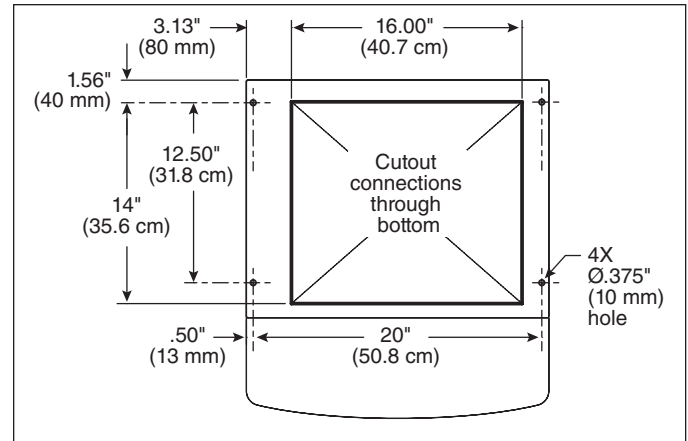

14. Cut countertop utility opening and drill four 7/16" holes to anchor dispenser to counter (Fig. 6).
15. Apply a thick bead approximately 1/4" (7 mm) diameter of NSF listed silicone sealant (Dow Corning* RTV-732 or equivalent) 1/4" (7 mm) inside marked outline of dispenser.
16. Reposition dispenser on counter and secure to counter with four 3/8"-16NC bolts.
17. Smooth excess sealant around outside of dispenser.
18. Make utility connections through countertop cutout.

CAUTION

- Do not connect water-cooled condenser outlet line to the dispenser drain line.

19. Turn on water supply and check for leaks.
20. Clean and sanitize dispenser and ice machine before putting into service.
21. Turn power on and allow ice machine to produce ice.

Installing wall mount dispensers

WARNING

- Wall mount dispensers are intended to be mounted above a sink, eliminating the need for a drain pan.
- Before beginning installation verify that the sink size and location meet the requirements shown in Fig. 7.
- If requirements are not met, a drain pan must be used to prevent ice and water from falling on counter or floor.
- FAILURE TO TAKE THESE PRECAUTIONS COULD RESULT IN SLIPS AND FALLS ON WET FLOORS

Fig. 7
Minimum sink requirements (without drain pan)

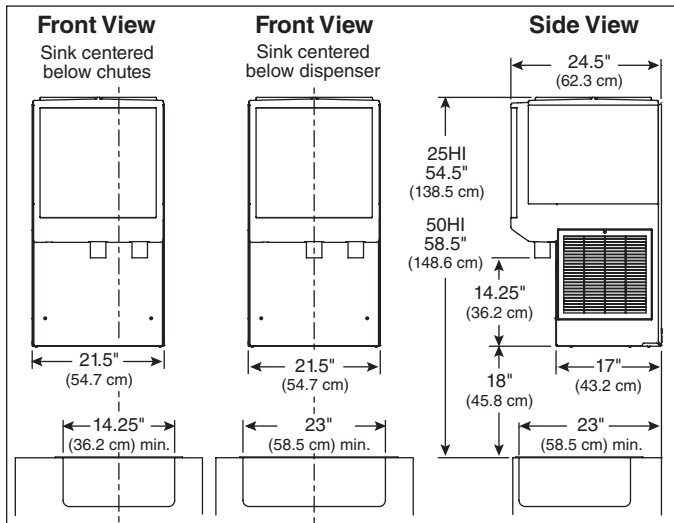

Fig. 8
Wall bracket location guide

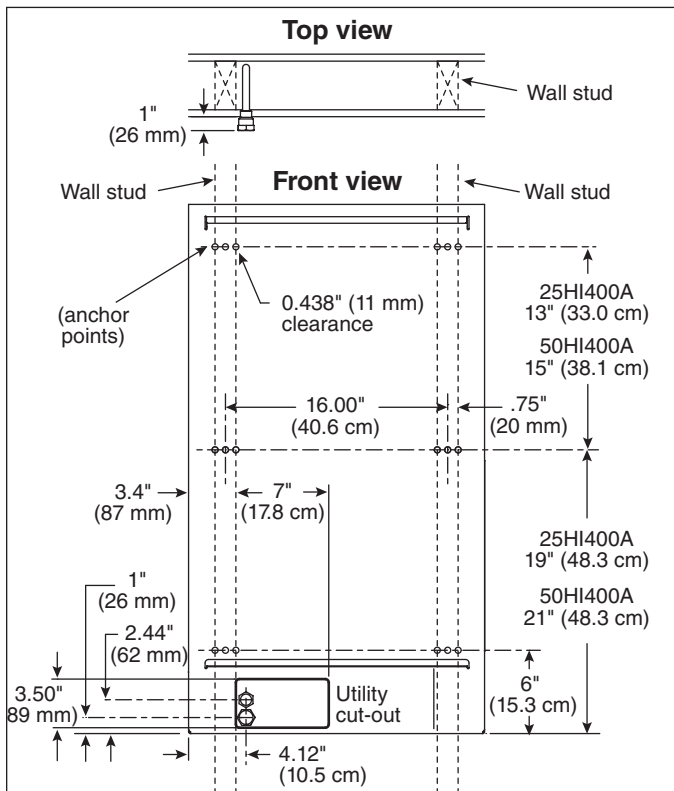
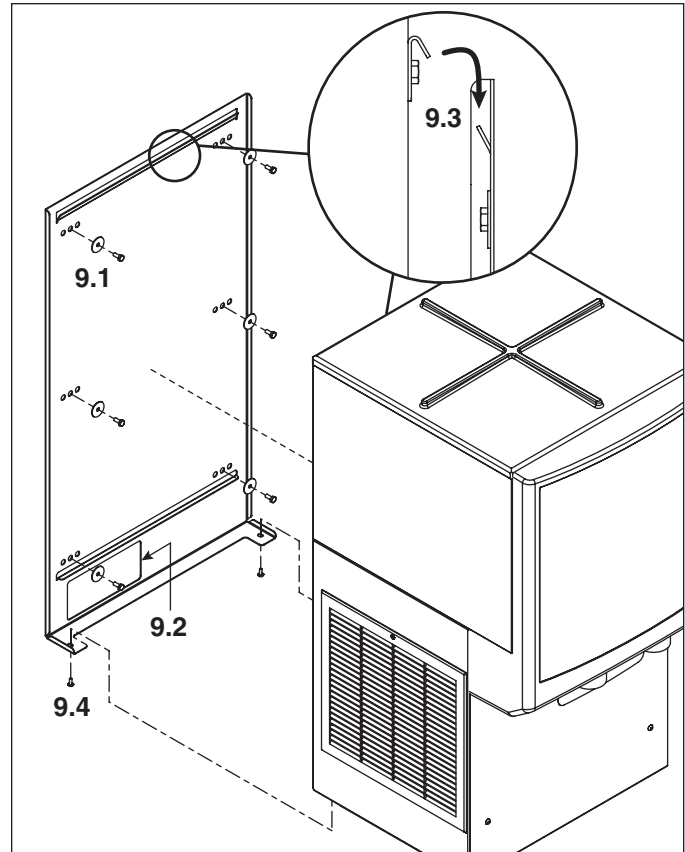
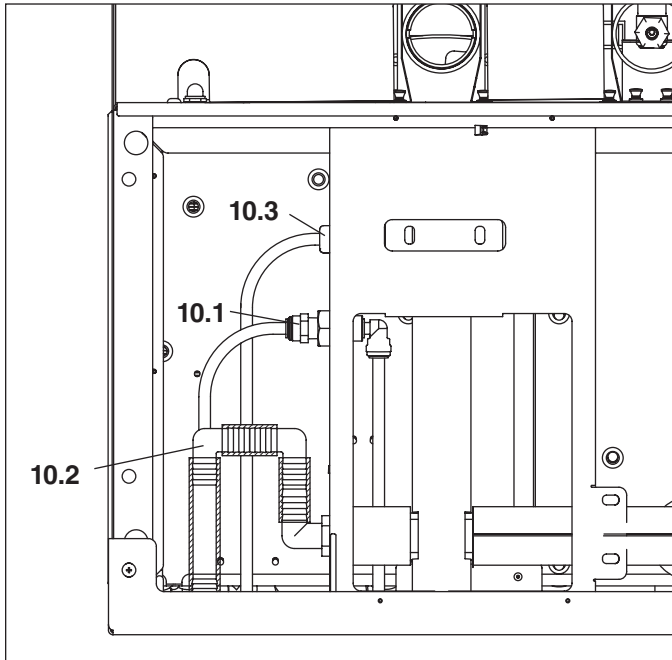

Fig. 9



1. Using Fig. 8 as a guide, locate wall bracket mounting position relative to wall studs.
2. Install the supplied wall bracket with six 3/8" diameter fasteners (Fig. 9.1).
Note: Three holes are available at each fastening site to allow capture of studs or supports within the wall.
2. Locate and cut utility hole in wall using Fig. 8 dimensions (9.2).
3. Rough in utilities. Wall mount bracket dimensions (Fig. 8) can be used as a template.
Water: 1/2" FNPT
Drain: 3/4" FNPT
4. Lift dispenser onto wall bracket positioning unit so that hook on back of dispenser is captured by wall bracket support angle (Fig. 9.3).
5. Install two 1/4" X 20 screws through bottom of wall bracket into bottom of dispenser to secure dispenser to wall bracket (Fig. 9.4).
6. Install supplied 1/2" MPT X 3/8" push-in adapter onto 1/2" FNPT water supply.

Fig. 10
Dispenser bottom view



7. Connect supplied 3/8" water line between water supply and water inlet fitting (Fig. 10.1).
8. Using supplied 3/4" drain tubing and barbed fittings, connect 3/4" barbed drain elbow fitting on dispenser to 3/4" FNPT drain (Fig. 10.2).
9. Route power cord through utility access hole to power supply (Fig. 10.3).
10. Turn on water supply and check for leaks.

Fig. 11

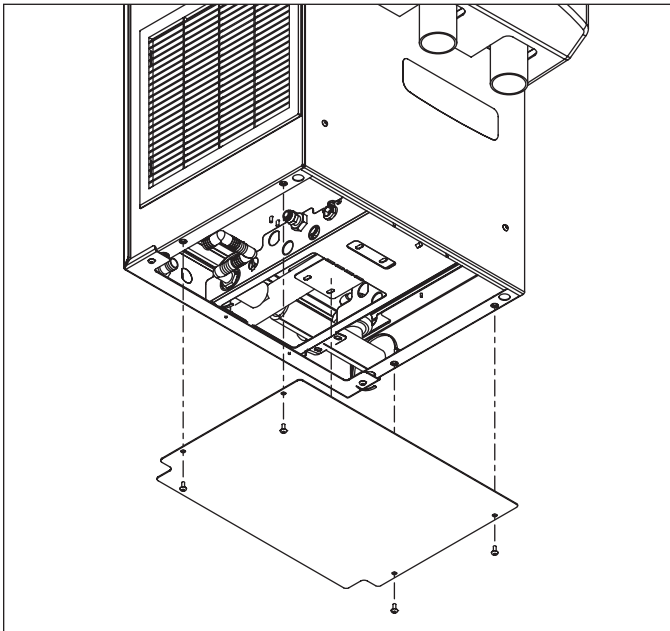

11. Install bottom panel (Fig. 11).

Cleaning/descaling and sanitizing

Periodic cleaning/descaling and sanitizing of Follett's ice and water dispenser and ice machine system is required to ensure peak performance and delivery of clean, sanitary ice. The recommended cleaning procedures that follow should be performed at least as frequently as recommended and more often if environmental conditions dictate.

Follett recommends sanitizing the pressurized water lines prior to cleaning/descaling and sanitizing the ice machine/dispenser. Follett offers two kits: order P/N 01089572 when a Follett filter system with a pre-filter bowl is present, or P/N 01089580 when a Follett filter system is not present. Follow the instructions provided with the respective kits to sanitize the pressurized water lines immediately before cleaning/descaling and sanitizing the ice machine/dispenser.

Cleaning of the condenser can usually be performed by facility personnel. Cleaning/descaling and sanitizing of the ice machine system should be performed by your facility's trained maintenance staff or a Follett authorized service agent. Regardless of who performs the cleaning, it is the operator's responsibility to see that this cleaning is performed according to the schedule below. Service problems resulting from lack of preventive maintenance will not be covered under the Follett warranty.

Recommended cleaning/descaling and sanitizing intervals*

Symphony	Frequency
Drain Line	weekly
Drain Pan/Drip Pan	weekly
Exterior	as needed
Air Filter	monthly
Condenser	monthly (air-cooled only)
Dispenser and Components	semi-annually
Ice Machine	semi-annually
Transport Tube	semi-annually
Ice Storage Area/Bin	semi-annually

* Ice machine and dispenser must be cleaned and sanitized prior to start-up.

Weekly



- Do not use solvents, abrasive cleaners, metal scrapers or sharp objects to clean any part of the dispenser.

Dispenser drain pan and drain line

- Pour 1 gal. (3.8 L) of hot tap water into drain pan to flush drains.

Splash panel front, SensorSAFE infrared dispensing

- Deactivate dispensing by pressing and releasing clean switch located on left side of unit under top front cover.
- Clean lens and splash panel front using a soft cloth and mild, non-abrasive, non-chlorine based cleaner.
- Reactivate dispensing by pressing and releasing clean switch again.

Monthly



- Do not use solvents, abrasive cleaners, metal scrapers or sharp objects to clean any part of the dispenser.

Condenser (air-cooled ice machine only)

- Use a vacuum cleaner or stiff brush to carefully clean condenser coils of lint and debris to ensure optimal performance.

Air Filter

1. Remove screw at top of louvered panel on left side of unit.
2. Slide panel toward back of dispenser and lift.
3. Remove the air filter located under the louver.
4. Clean with soap and water.
5. Rinse, and replace when completely dry.

Semi-Annually (more often if conditions dictate)

- A cleaning/descaling and sanitizing procedure should always include both the ice machine and dispenser; ice machine should be cleaned and sanitized first, followed by the dispenser.
- Icemaking system can be cleaned/descaled in place.

To ensure that your ice machine and dispenser are cleaned/descaled and sanitized properly, proceed as follows:

1. Clean/descale the ice machine
2. Sanitize the ice machine
3. Clean/descale the dispenser
4. Sanitize the dispenser



CAUTION!

- Wear rubber gloves and safety goggles (or face shield) when handling cleaner or sanitizer mixtures.
- Use only Follett approved cleaners.
- It is a violation of Federal law to use Solution A or Solution B in a manner inconsistent with their labeling.
- Do not use solvents, abrasive cleaners, metal scrapers or sharp objects to clean any part of the dispenser.

Solution A: Following manufacturer's instructions, mix cleaning solution of 1 gal. (3.8 L) 120 F (49 C) water and 7 oz. (198 g) (one 7 oz. packet) of Follett SafeCLEAN™ ice machine cleaner/descaler (P/N 00132001).

Solution B: Following manufacturer's instructions, mix a sanitizing solution of 1 gal. (3.8 L) 120 F (49 C) water and 1.6 oz. (48 ml) Nu-Calgon IMS-II Sanitizer (P/N 00979674).

Clean/descale ice machine

1. If ice machine was running recently, ensure that the evaporator is completely free of ice before proceeding.
2. Disconnect power to ice machine.
3. Remove any ice machine panels required to gain access to water reservoir and electrical control box.
4. Turn compressor switch on electrical box of ice machine to OFF position.
5. Remove water reservoir cover and close water supply valve (or block up reservoir float).
6. Drain water from reservoir by releasing evaporator drain tube from float reservoir bracket, removing plug from drain tube and releasing (unclamping) pinch clamp (if equipped).
7. Plug drain hose, replace drain line in reservoir bracket and pour part of **Solution A** into reservoir, filling it almost to overflowing.
8. Remove stainless steel ice compression nozzle and drain lines and submerge in a cup of **Solution A** while cleaning/descaling rest of system. (Flake ice machines have no ice compression nozzle and drain lines.)
CAUTION: To avoid potential pitting, do not soak parts in **Solution A** for more than 45 minutes.
9. Restore power to ice machine (garmotor will run; compressor and fan will not).
10. Inspect evaporator drain pan and drain line and remove any accumulated scale build up.
11. After 15 minutes, turn power OFF; drain solution from reservoir and evaporator.
12. Fill reservoir almost to overflowing with clean water to rinse. Drain. Repeat two more times.
13. Rinse ice compression nozzle and drain lines in clean water.

Sanitize ice machine

14. Submerge ice compression nozzle and drain lines in a cup of **Solution B** while following steps 15-21.
15. Connect ice transport tube directly onto evaporator outlet port without ice compression nozzle.
16. Fill reservoir almost to overflowing with **Solution B**.
17. Restore power to ice machine (gearmotor will run; compressor and fan will not).
18. After 10 minutes, turn compressor switch to ON position.
19. As unit starts to make ice, continue to pour **Solution B** into reservoir, maintaining level just below reservoir overflow.
20. Continue to make ice with **Solution B** for 20 minutes.
21. Turn power to ice machine OFF.
22. Disconnect ice transport tube from evaporator outlet port. Rinse ice compression nozzle and drain lines in clean water and reinstall on evaporator outlet. Reconnect ice transport tube to ice compression nozzle.
23. Drain any remaining **Solution B** from evaporator.
24. Fill reservoir almost to overflowing with 120 F (49 C) clean water to rinse. Drain. Repeat two more times. Re-clamp pinch clamp, replace drain plug, and re-secure drain tube *ensuring that end of drain tube is above water level in reservoir*.
25. Open water supply valve (or unblock float) and replace reservoir cover; restore power to ice machine and ensure compressor switch is in ON position. Make ice for at least 15 minutes to flush any remaining **Solution B** from system (RIDE® ice machines with long ice transport hoses may take longer to flush out). Discard this ice and all ice made during sanitizing.

Clean/descale dispenser

26. Remove *and discard* all ice from storage hopper.
 27. Ensure power is disconnected. Working inside storage area, remove center thumbscrew from dispense wheel, tilt wheel up toward back to clear baffle and disengage wheel from motor shaft.
 28. Remove dispense chutes.
 29. Thoroughly wipe lid, dispense wheel, baffle and dispense chutes with cloth soaked in **Solution A**.
 30. Wipe all bin surfaces (including the area under dispense wheel) with a damp cloth wrung out in **Solution A**.
- Note:** To avoid possible damage to dispense motor assembly, use only a *damp* cloth to clean the storage bin. Do not allow water to run through bottom of bin area.
31. Remove grille and wash with **Solution A**. Rinse thoroughly with clean water.
 32. Rinse all above items with damp cloth wrung out in clear water.

Sanitize dispenser

33. Wipe all above items with damp cloth wrung out in **Solution B** to sanitize. Do not rinse.
34. Reinstall all parts and replace any panels removed prior to cleaning.
35. Pour 1 gal. (3.8 L) of hot tap water into drain pan to flush drains.
36. Turn ice machine ON and begin to make ice (ice machine should start immediately with power and bin signal supplied).
37. After approximately 30 minutes, test dispenser for proper dispensing.

Service

Ice machine operation

Follett's ice machine consists of four distinct functional systems:

- Refrigeration system
- Water system
- Harvesting system
- Electrical control system

These four systems work together to accomplish the production and harvesting of ice. A problem in any one of these systems will result in improper operation of the entire ice production cycle. When troubleshooting the ice machine, it is important to analyze the entire system operation to determine which system is not functioning properly, then pinpoint the component within that system that is malfunctioning. Determine what corrective action must be taken before making any adjustments or replacing any components.

The icemaking process

The Follett ice machine uses a stainless steel jacketed evaporator and operates on a continuous freezing cycle. Water is supplied to the evaporator from the water reservoir where the water level is controlled by a float valve. This valve also shuts off the water supply when the ice machine is not running.

When the ice machine is running, a layer of ice forms on the interior surface of the evaporator. This ice is continuously removed by a slowly rotating (12 RPM) auger.

The auger carries the ice upward into the cavity formed by the top bearing housing and the compression loop, where it is compressed to remove excess water.

When the ice reaches the desired hardness it rotates within the cavity and is forced through a discharge port and compression nozzle and into the ice transport tube. The discharge tube and compression nozzle are slightly restricted to further compress the ice and produce the desired hardness. As the formation of ice continues, ice in the transport tube is pushed through the tube to the storage compartment in the ice dispenser.

A solid state control board, located in the electrical box of the ice machine, controls the normal operation of the ice machine and monitors gearmotor torque. This control board will shut down the ice machine should an over-torque condition occur. It is very important that you familiarize yourself with the operational sequences detailed in this manual before attempting to service the ice machine.

Ice harvest system diagram

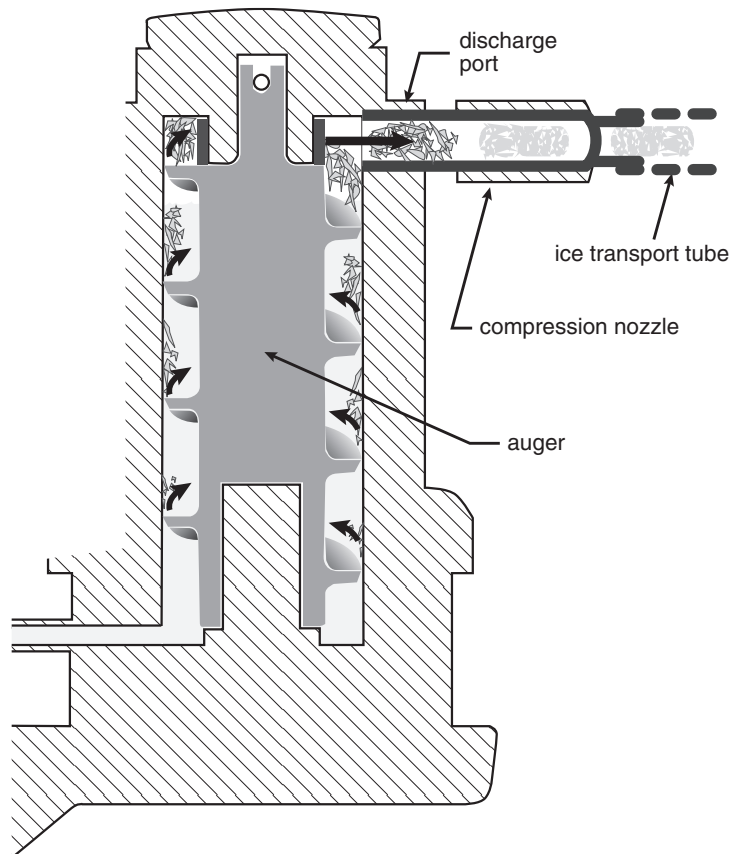

Disassembly and replacement instructions

Dispense wheel removal and installation

1. Remove all ice from storage area of dispenser.
2. Remove center thumb nut from dispense wheel.
3. Remove thumb nuts holding baffle inside bin and remove baffle.
4. Tilt rear of wheel up and lift off motor drive shaft.
5. After reinstalling wheel, secure baffle loosely with thumb nuts, but do not tighten.

Fig. 12

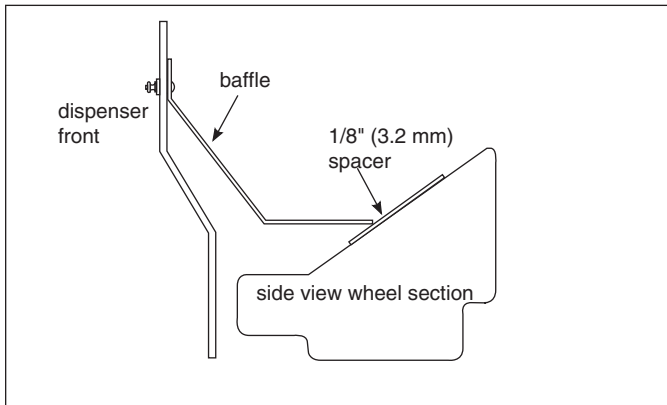

6. Place a 1/8" (3.2 mm) spacer against wheel and allow baffle to drop until it touches spacer (Fig. 12).
7. Tighten thumb nuts and remove spacer.

Drive bar removal

1. Remove dispense wheel from dispenser (see above).
2. Pull drive bar out of its channel in bottom of wheel.

Wheel motor assembly removal

1. Disconnect power.
2. Remove top cover and dispense wheel.
3. Slide ice machine out of dispenser as described on page 16, ice machine removal. Ice machine does not need to be removed completely if there is sufficient clearance to access the dispenser motor through the right louvered panel.
4. Disconnect wires on motor.
5. Remove four bolts (7/16" socket) holding motor assembly to bottom of dispenser.
6. Remove motor assembly.

Ice transport tube replacement

CAUTION

- Tubing must be supplied by Follett Corporation

1. Disconnect power. Remove top and partially slide ice machine out of dispenser as described on page 16.
2. Disconnect end of tube from ice machine.

3. Disconnect existing ice tube from engaging pin on transport tube bracket in ice storage bin and pull tube up through dispenser chase.

Fig. 13

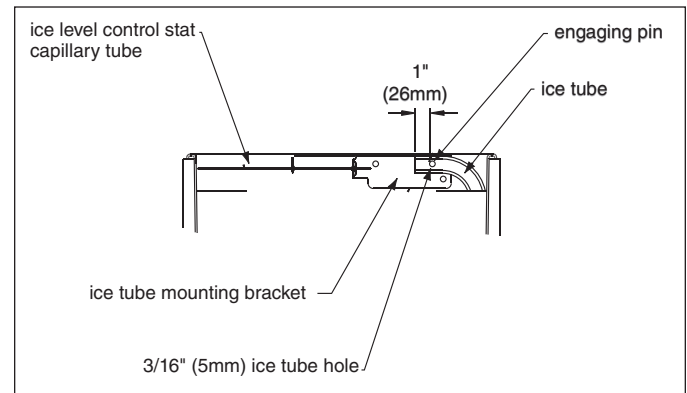

4. Run the new ice transport tube down through chase making sure that the end with the 3/16" (5 mm) hole is in the bin (Fig. 13).

Fig. 14

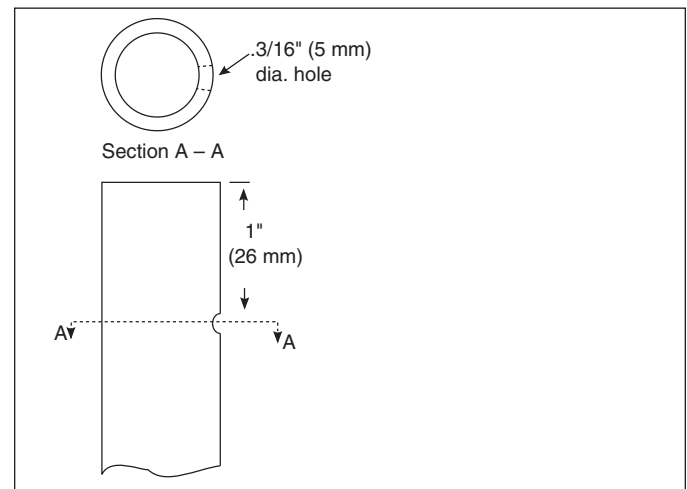

5. Push the 3/16" (5 mm) hole near end of tube into pin on ice tube bracket (Fig. 14).
6. Reinstall insulation

Fig. 15

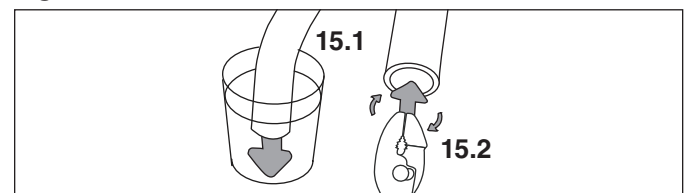

7. Heat end of transport tube in cup of 160 F (71 C) hot water to soften (Fig. 15.1) and spread with pliers before making connection (Fig. 15.2).
8. Slip supplied hose clamp onto tube and push tube onto compression nozzle on exit port of evaporator. Do not twist tubing when securing to evaporator.
9. Secure tube on port with hose clamp, being sure that clamp is positioned on evaporator side of nozzle flange.

Ice machine removal



WARNING

To reduce risk of shock disconnect power before servicing.

Fig. 16– All models

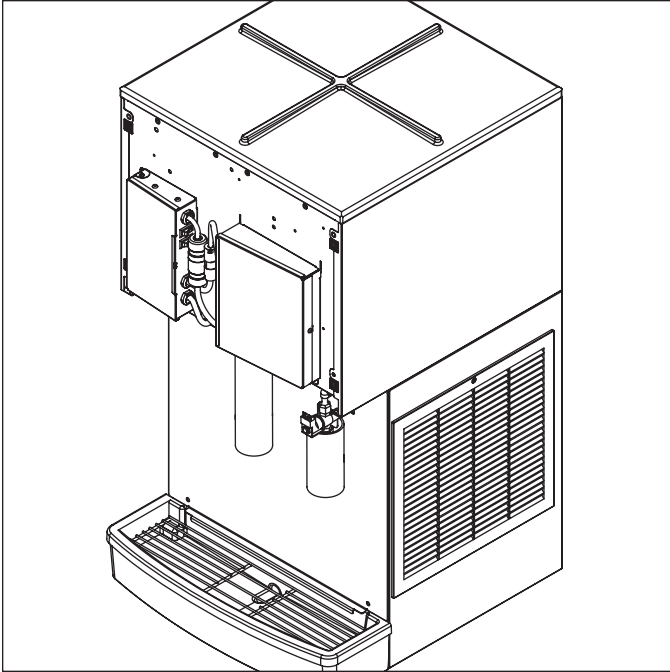

1. Remove front cover (Fig. 16).

Fig. 17 – All models

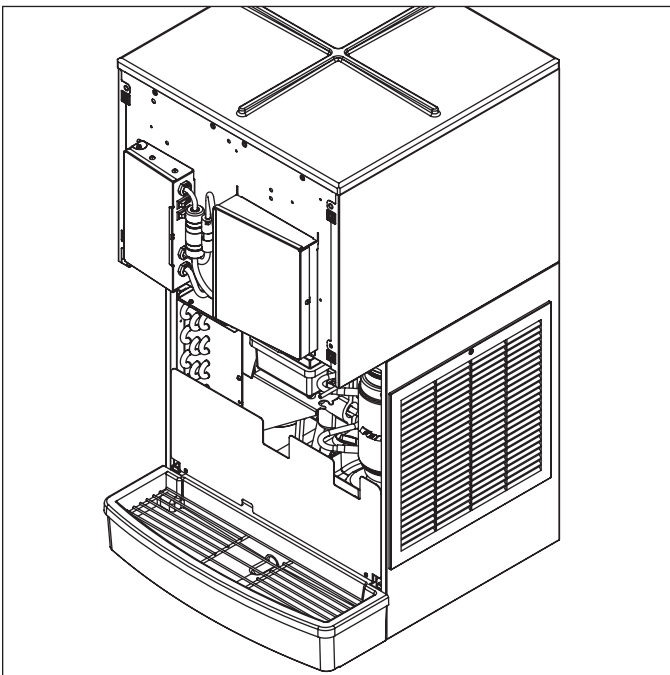

2. Remove splash panel (Fig. 17).

Fig. 18 – All models

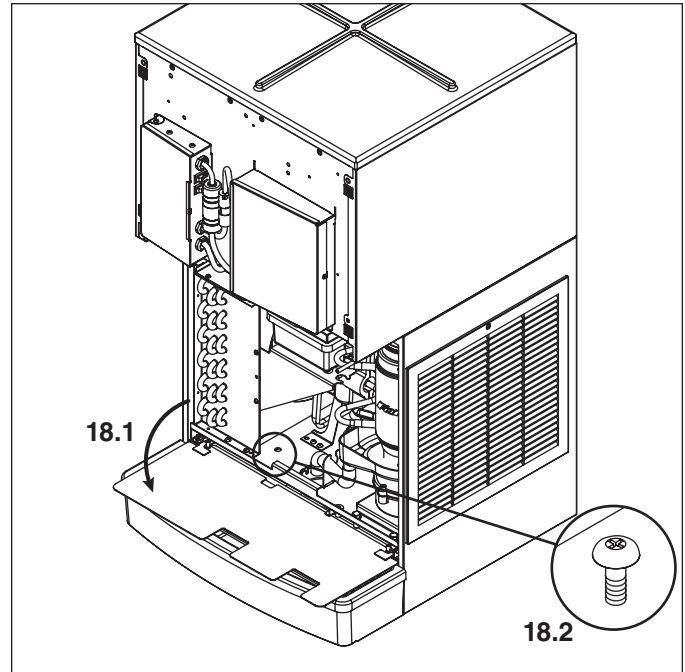

3. Lower drain pan protector (Fig. 18.1). Remove and discard shipping screw (Fig. 18.2).

Fig. 19 – All models

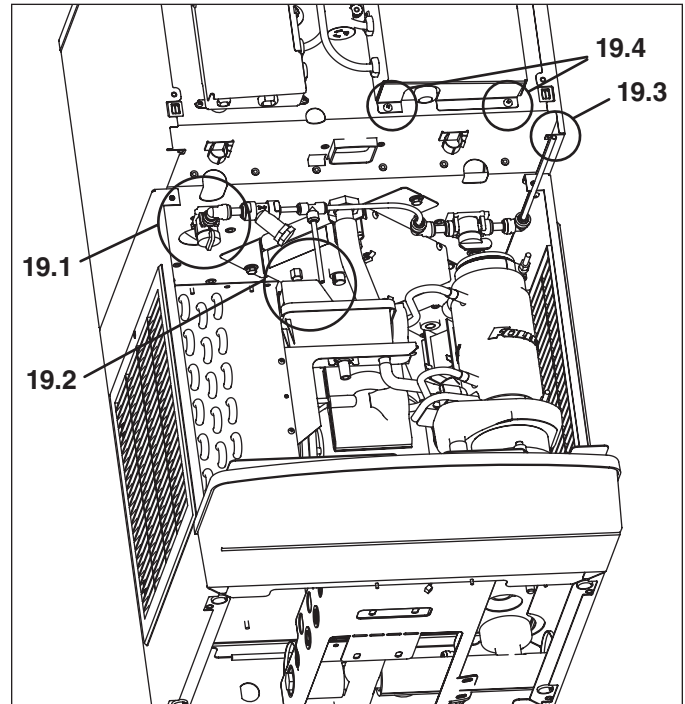

4. Close main water shut off valve (Fig. 19.1).
5. Disconnect water line to float valve (Fig. 19.2).
6. Disconnect water line to solenoid (Fig. 19.3).
7. Remove screws securing bottom of ice machine electrical box (Fig. 19.4).

Fig. 20 – Water-cooled only

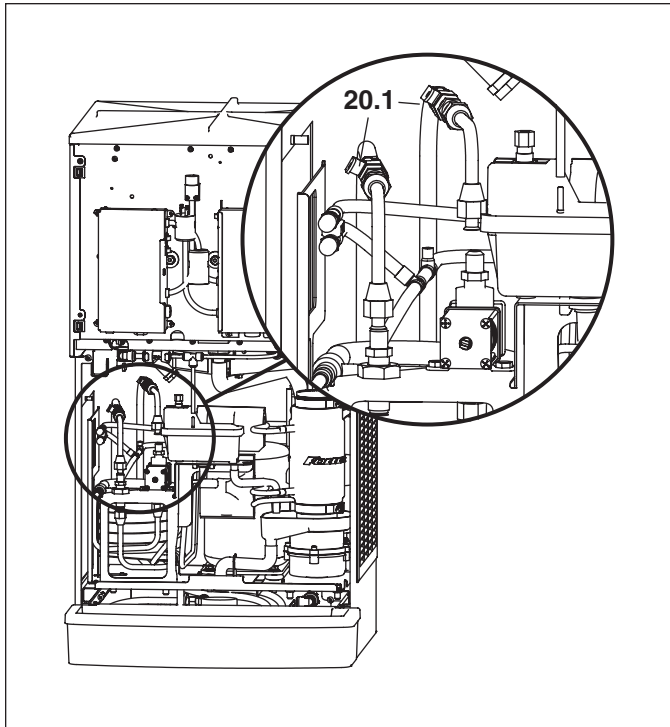

7. Shut off inlet and outlet valves to water-cooled condenser and disconnect fittings (Fig. 20.1).

Fig. 21 – Water-cooled only

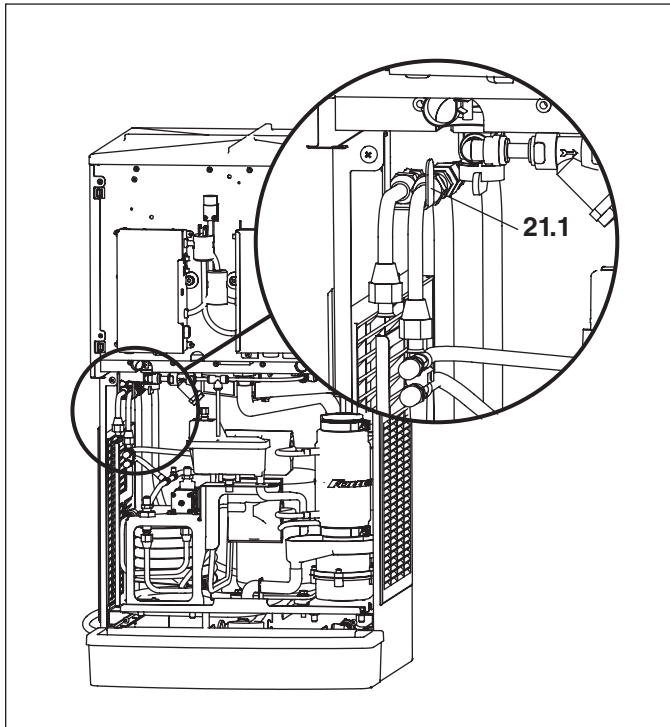

8. Lift and position water-cooled lines into hook (Fig. 21.1).

Fig. 22 – All models

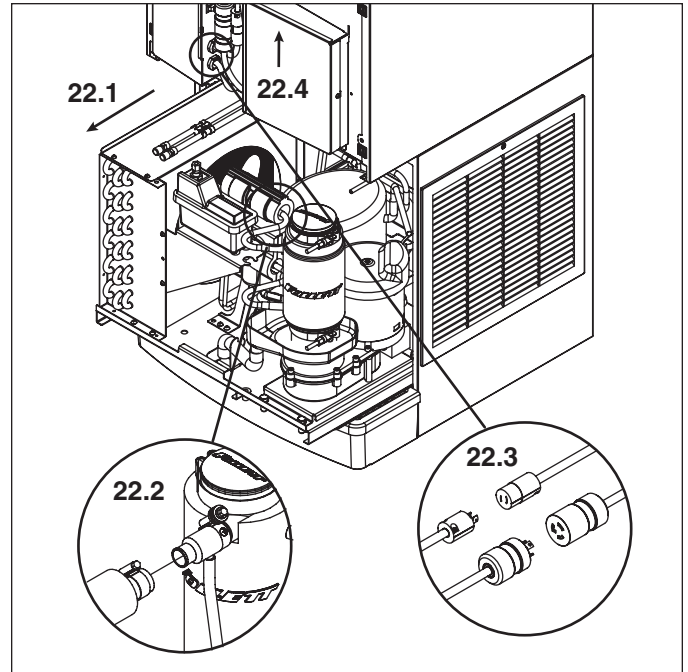

9. Partially slide ice machine from dispenser (Fig. 22.1).
10. Loosen clamp and disconnect ice transport tube from evaporator (Fig. 22.2).
11. Disconnect power and bin signal twist lock connectors (Fig. 22.3).
12. Slide ice machine electrical box up and off unit (Fig. 22.4).

Fig. 23 – Air-cooled only

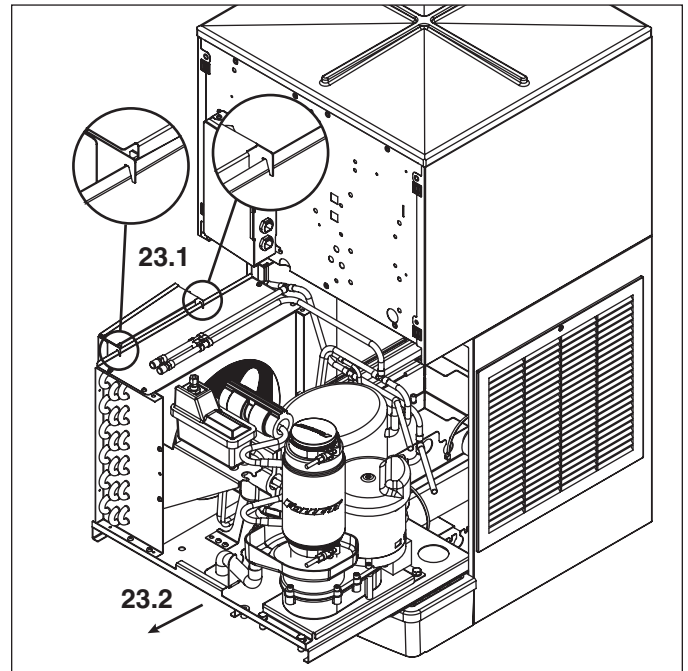

13. Use hooks on ice machine electrical box to hang box on front of condenser (Fig. 23.1).
14. Remove ice machine from dispenser (Fig. 23.2). Note warning (Fig. 25).

Fig. 24 – Water-cooled only

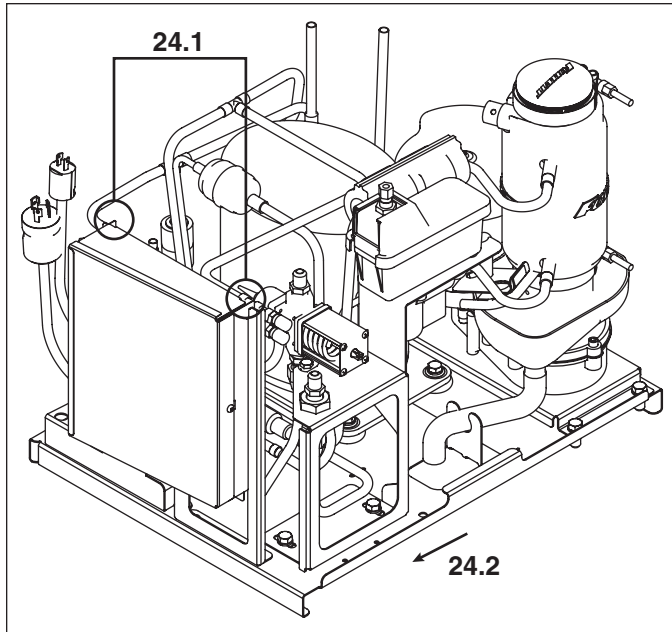

13. Use hooks on ice machine electrical box to hang box on bracket (Fig. 24.1).
14. Remove ice machine from dispenser (Fig. 24.2).

Fig. 25 – All models

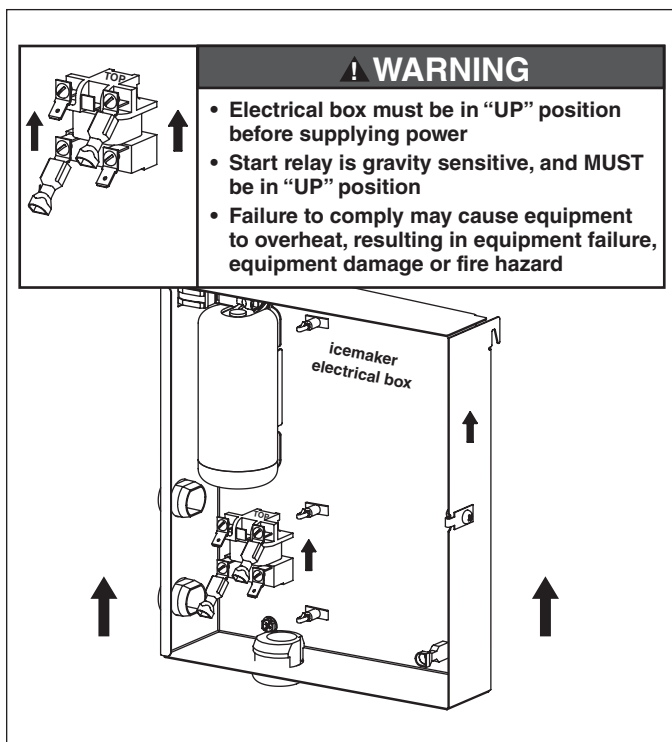

Evaporator disassembly

Note: The upper bearing, lower bearing and auger assemblies must be replaced as assemblies. The bottom and top bearing assemblies cannot be field assembled to factory specifications (Fig. 26).

1. Disconnect power to ice machine.
2. Shut off water to ice machine.
3. Drain evaporator and float tank.
4. Disconnect plastic tubing from evaporator water inlet.
5. Disconnect compression nozzle tubing and reservoir overflow tubing from secured clip.
6. Remove nut and upper vee-band coupling from top of evaporator.
7. Lift top bearing assembly straight up with a slight rotating motion and remove.
8. Remove ice compression loop located at top of auger.
9. Lift auger straight up and out of evaporator.
10. Remove nut and lower vee-band coupling from bottom of evaporator.
11. Lift evaporator to clear bottom bearing assembly.
12. Loosen hex head bolt in side of mounting base with 5/16" wrench and lift lower bearing assembly.
13. Remove condensate shield.
14. Remove four Allen head machine screws holding mounting base to gearbox.
15. If replacing evaporator, remove compression nozzle from evaporator port.

Fig. 26

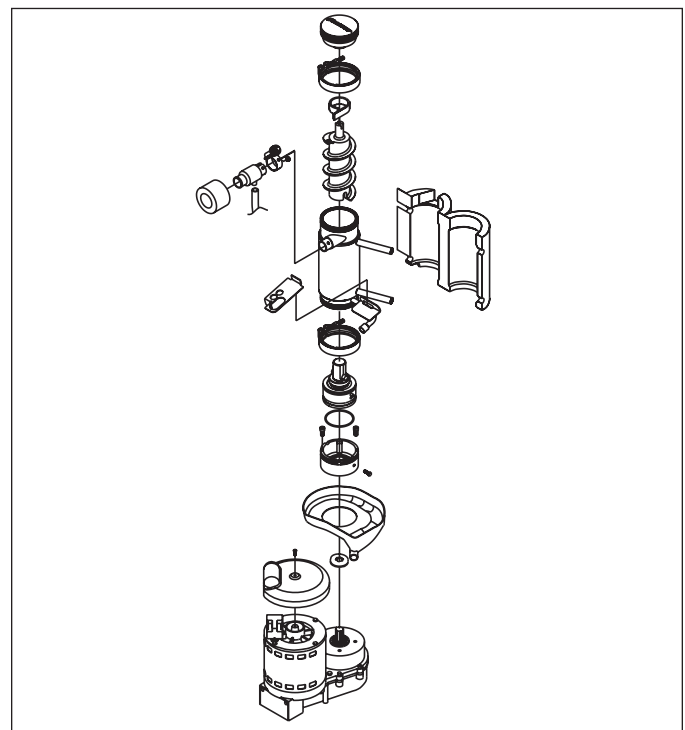

Evaporator reassembly

1. Clean gearmotor boss, output shaft and shaft well.
2. Install drain pan and evaporator mounting base.
3. Fill gear motor shaft well with food grade grease (Fig. 27.1).
4. Install condensate shield and seat against gear motor boss.
5. Install bearing O ring in groove in evaporator mounting base.
6. Lower bottom bearing assembly into evaporator mounting base.
7. While maintaining a slight downward pressure on bottom bearing assembly, tighten hex head bolt with a 5/16" wrench.
8. Position evaporator over lower bearing assembly and align grooves with pins in bearing assembly.
9. Install vee band clamp and nut to 70 in/lb.
10. Place auger in center of evaporator and rotate to mate with drive pin.
11. Install ice compression loop, orienting loop as shown in Fig. 28.
12. Install upper bearing and seal assembly, rotating bearing to slip pin into auger slot.
13. Install upper vee band clamp and nut to 70 in/lb.
14. If evaporator was replaced, reinstall compression nozzle on new evaporator.

Fig. 27

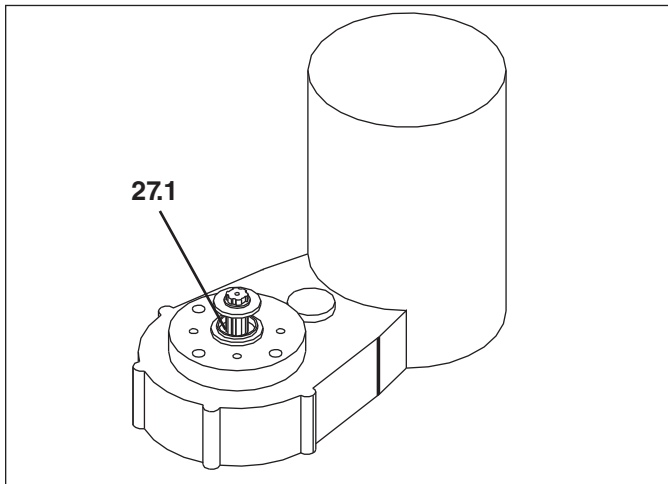
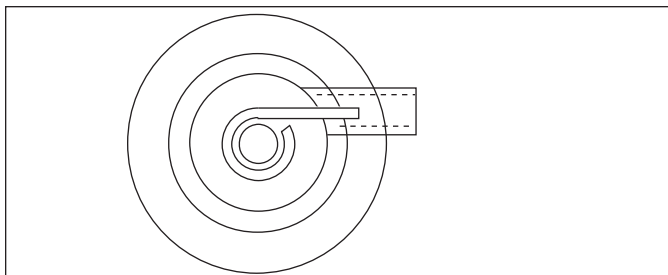

Fig. 28



Gearmotor replacement

1. Disassemble evaporator as described above.
2. Disconnect the wire connectors.
3. Remove four screws holding gear motor mounting plate to base of ice machine and lift gearbox and motor clear of ice machine.
4. Remove machine screws holding mounting plate to motor.
5. Install new motor in reverse order.

Fan removal

Fig. 29

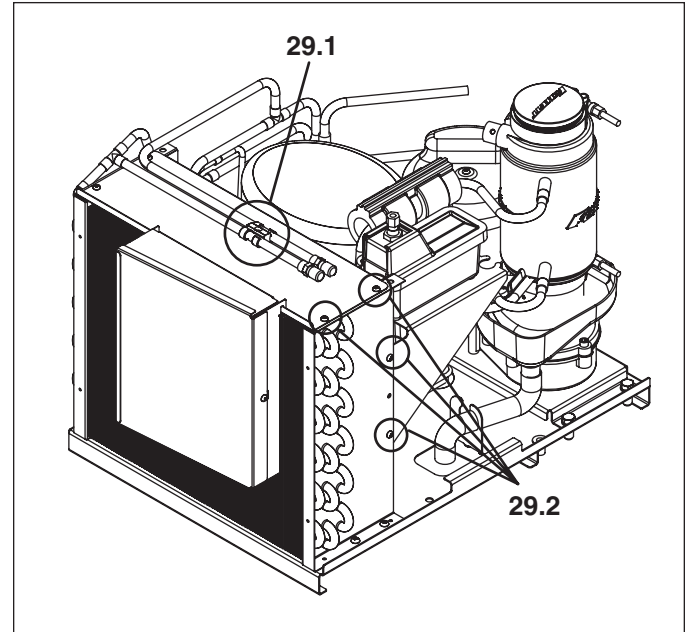

1. Remove screw securing refrigerant lines to condenser shroud (Fig. 29.1).
2. Remove seven screws securing shroud to condenser (Fig. 29.2).
3. Slide shroud forward against fin block to access fan and motor.

Electrical systems

 **WARNING**
To reduce risk of shock disconnect power before servicing.

 **WARNING**

- Electrical box must be in “UP” position before supplying power
- Start relay is gravity sensitive, and MUST be in “UP” position
- Failure to comply may cause equipment to overheat, resulting in equipment failure, equipment damage or fire hazard

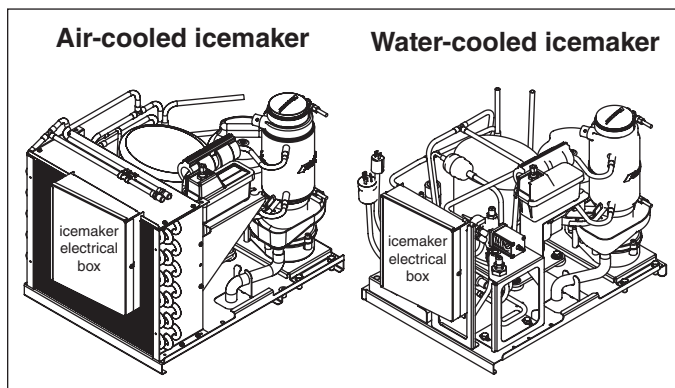
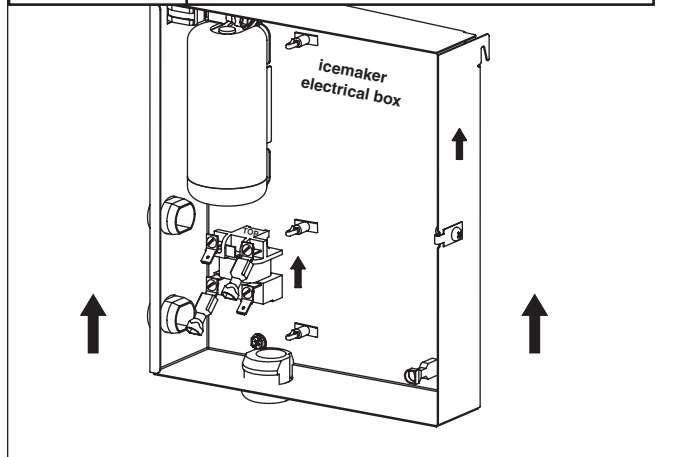

Electrical component locations

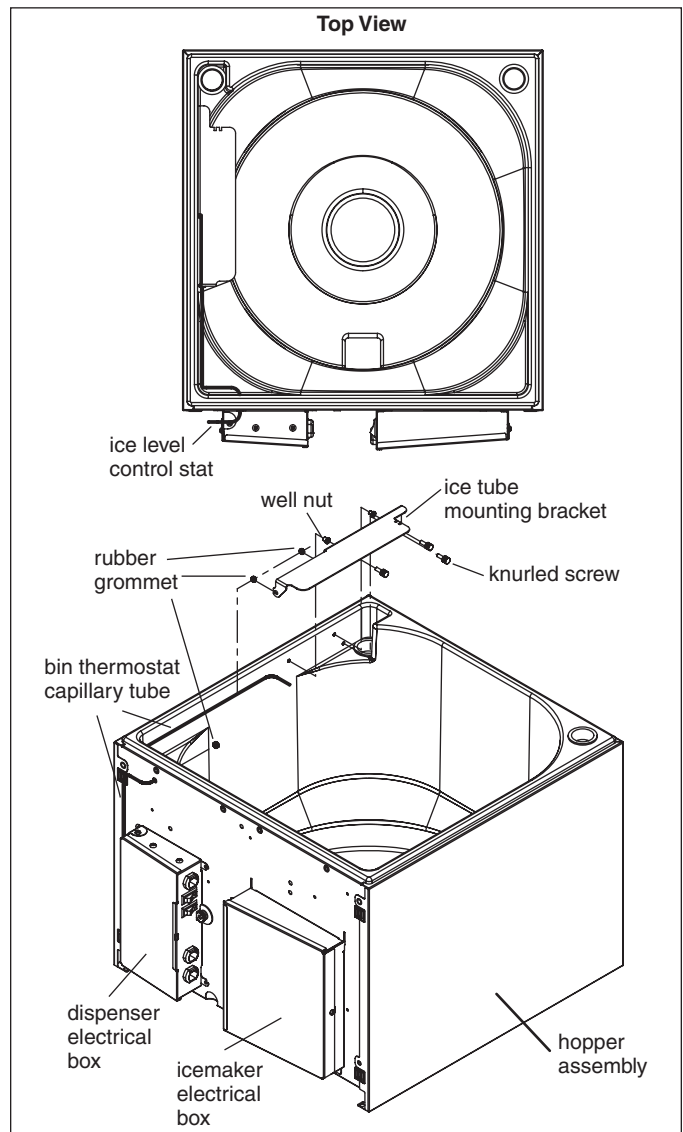

Wiring diagram - lever dispense model

Lever Dispensing Wiring Diagram

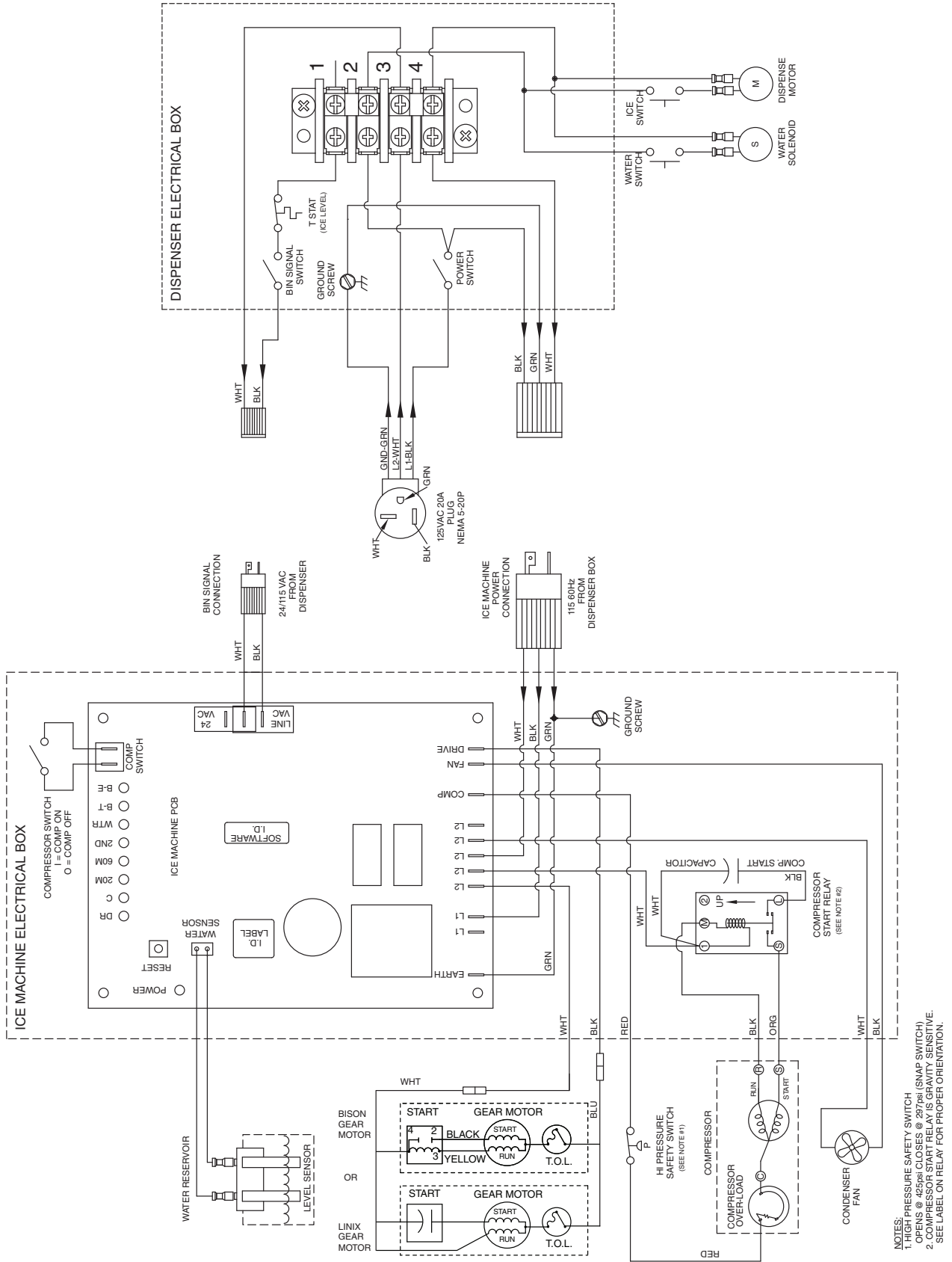

Wiring diagram - SensorSAFE model

SensorSAFE Dispensing Wiring Diagram

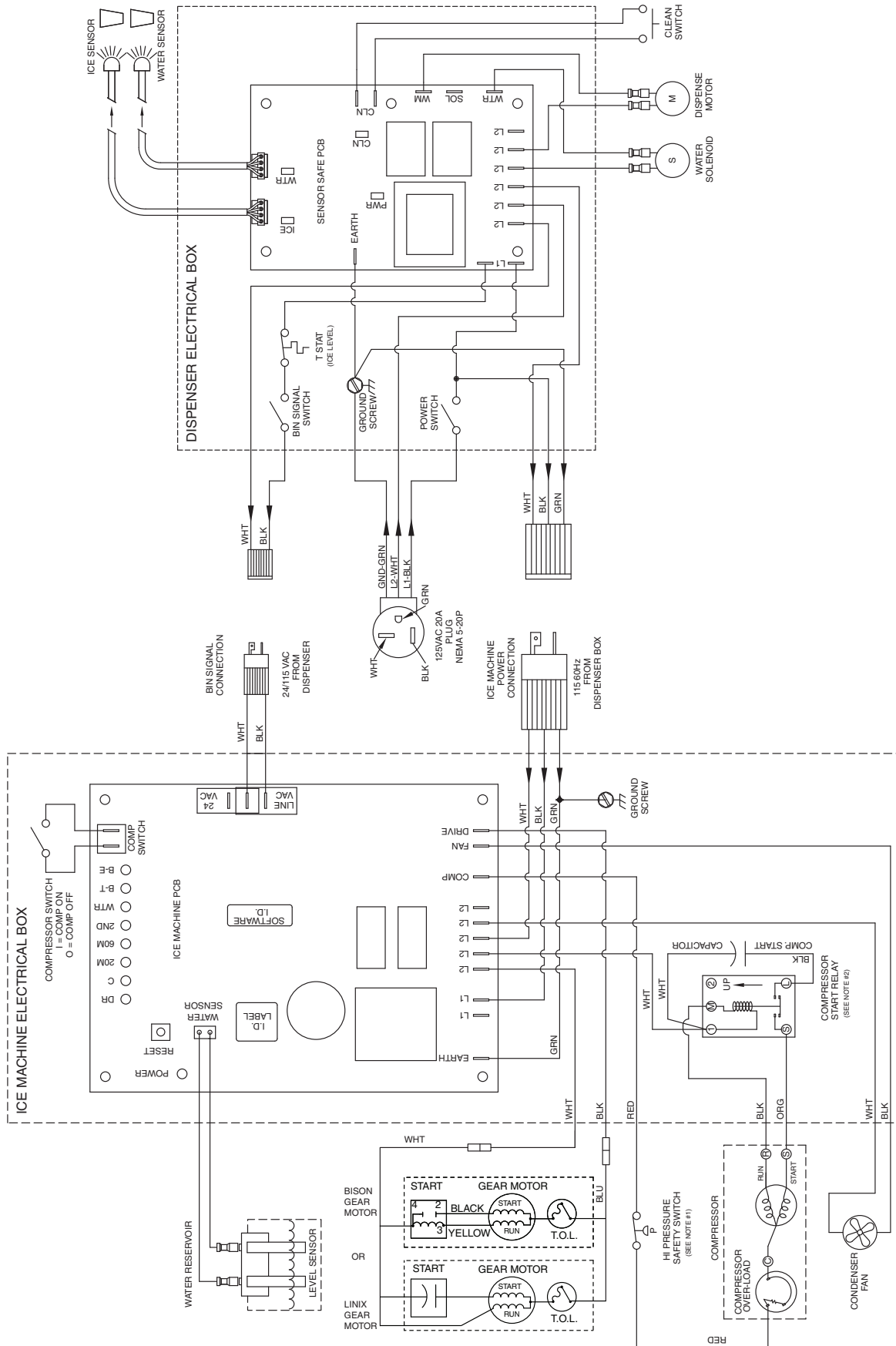

NOTES:
 1. HIGH PRESSURE SAFETY SWITCH
 OPENS @ 425psi CLOSSES @ 297psi (SNAP SWITCH)
 2. COMPRESSOR START RELAY IS NORMALLY CLOSED.
 SEE LABEL ON RELAY FOR PROPER ORIENTATION.

Ice machine operational and diagnostic sequences

The wiring diagrams that follow illustrate the circuitry of Follett ice machines. Both normal operation (stages 1 - 6) and non-normal diagnostic sequences showing torque-out (stages 7 - 10) for use in troubleshooting are shown.

Circuitry notes

The ice machine receives power from two sources – the main power supply and the bin control signal power from the dispenser. Disconnect both power sources before performing service. When performing electrical service, always use a meter to determine whether or not the components being serviced are energized.

High pressure cutout opens at 425 pso and closes at 287 psi (auto reset).

Compressor switch should read open in ON position.

Compressor start relay is position sensitive.

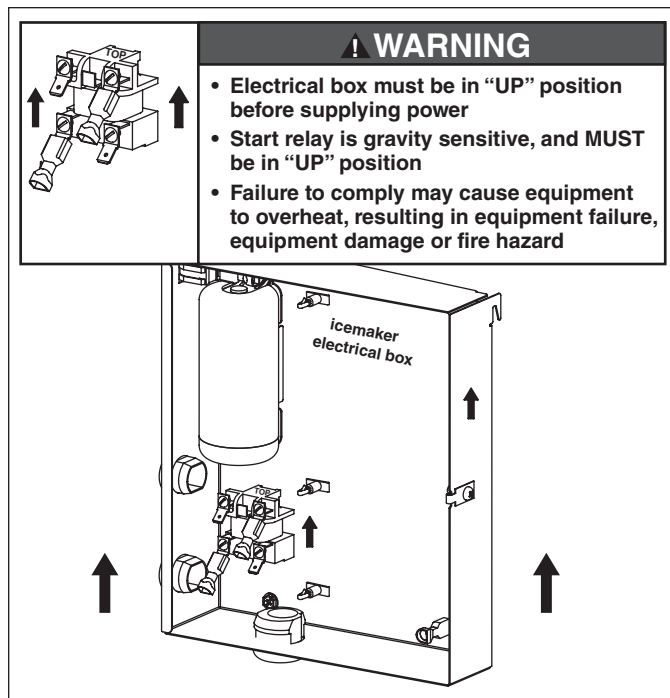

Bin signal is 115 V, 60 Hz.

Flashing water LED at any time indicates that water signal to board has been lost for more than one second.

Ten-second delay: There is a 10 second delay in reaction to loss of water (WTR) or bin (B-E) signals. If signals are not lost for more than 10 seconds, no reaction will occur.

Normal operation – Stage 1

Power is supplied to L1 of the control board. The ice level control in the dispenser is closed and calling for ice, supplying signal voltage to the control board. The control board will now go through the start-up sequence. Less than 30 seconds will elapse as the water sensor located in the float reservoir checks for water in the reservoir. The bin empty LED (B-E) and power LED (PWR) will be on.

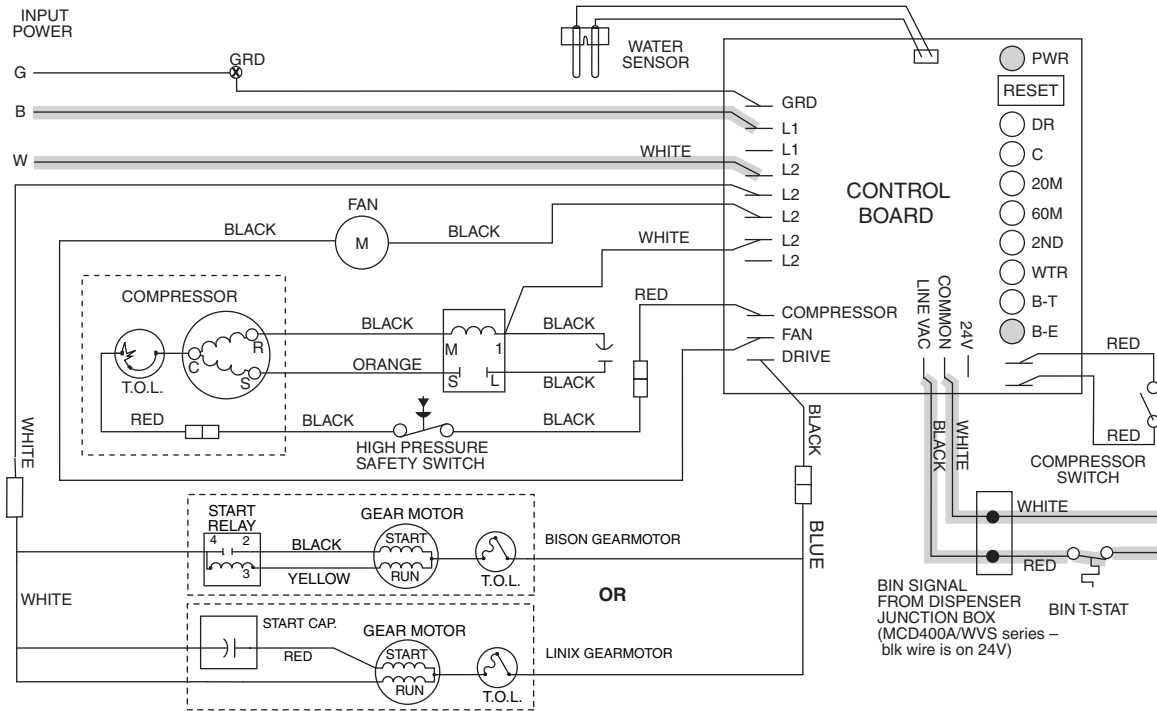

Normal operation – Stage 2

The water sensor verifies water in the float. The Water OK LED (WTR) comes on. At the same time, the gearmotor, compressor, and condenser fan motor come on, lighting the Drive LED (DR) and compressor LED (C). The compressor is started through a current style relay that is pulled in by the initial high current draw of the compressor. The gearmotor start windings are also energized through a current relay (or start capacitor). The B-E and WTR LED remain on.

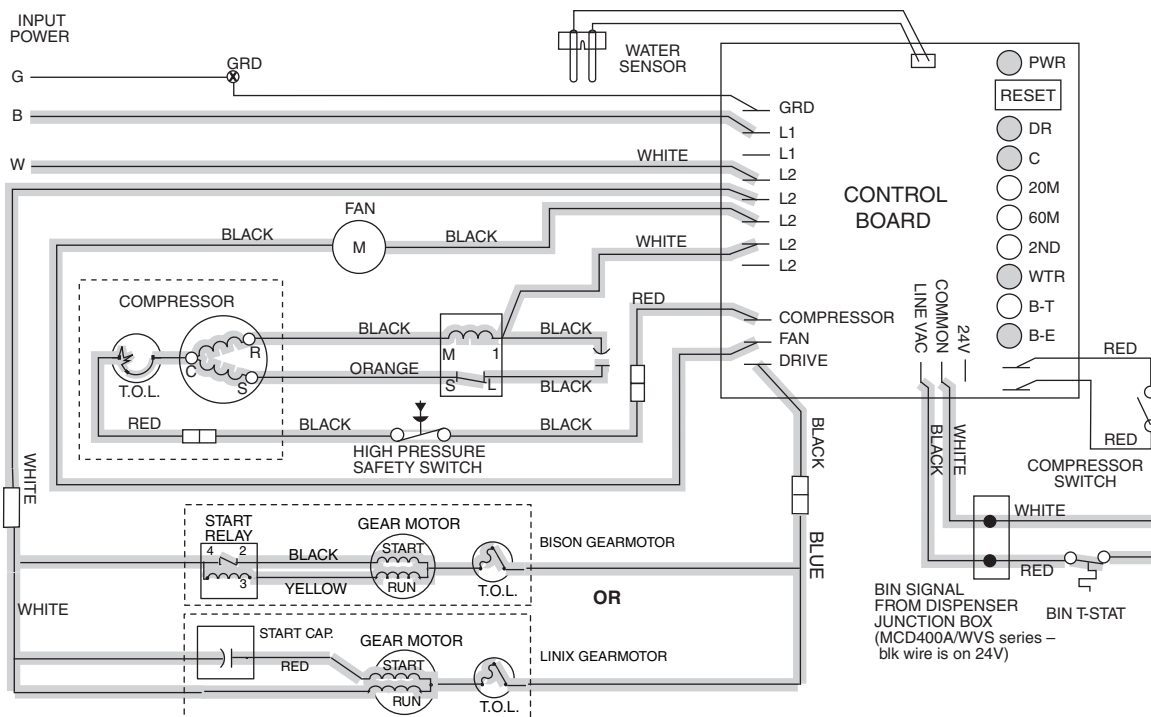

Normal operation – Stage 3

After the initial high current draw drops off, the gearmotor start relay contacts open, dropping out the start winding (or start capacitor). As the compressor comes up to normal running speed, the compressor start relay contacts also open, dropping out the start winding of the compressor. The ice machine is now in a normal icemaking mode. The ice machine will begin to produce ice and continue to produce ice until the bin level control in the ice dispenser is satisfied. The PWR, B-E, DR, C and WTR LEDs are all on.

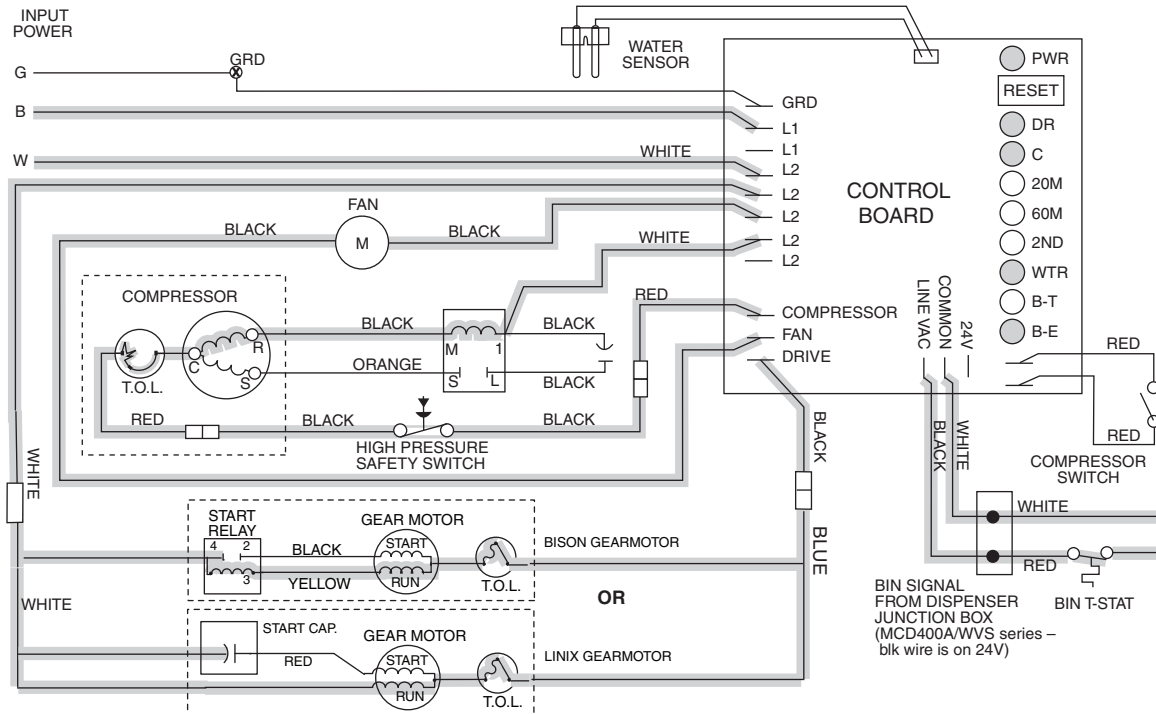

Normal operation – Stage 4

Once the ice level control opens, the B-E LED goes out. After a 10 second delay the compressor LED (C), compressor and fan motor go off. (Should the ice level control not remain open for 10 seconds, the ice machine will continue to run.) The gearmotor continues to run and the DR LED remains lighted for 60 seconds. The purpose of this function is to drive the remaining ice out of the evaporator and to boil off any refrigerant remaining in the evaporator. The bin timer LED (BT) comes on, starting the twenty minute off cycle time delay.

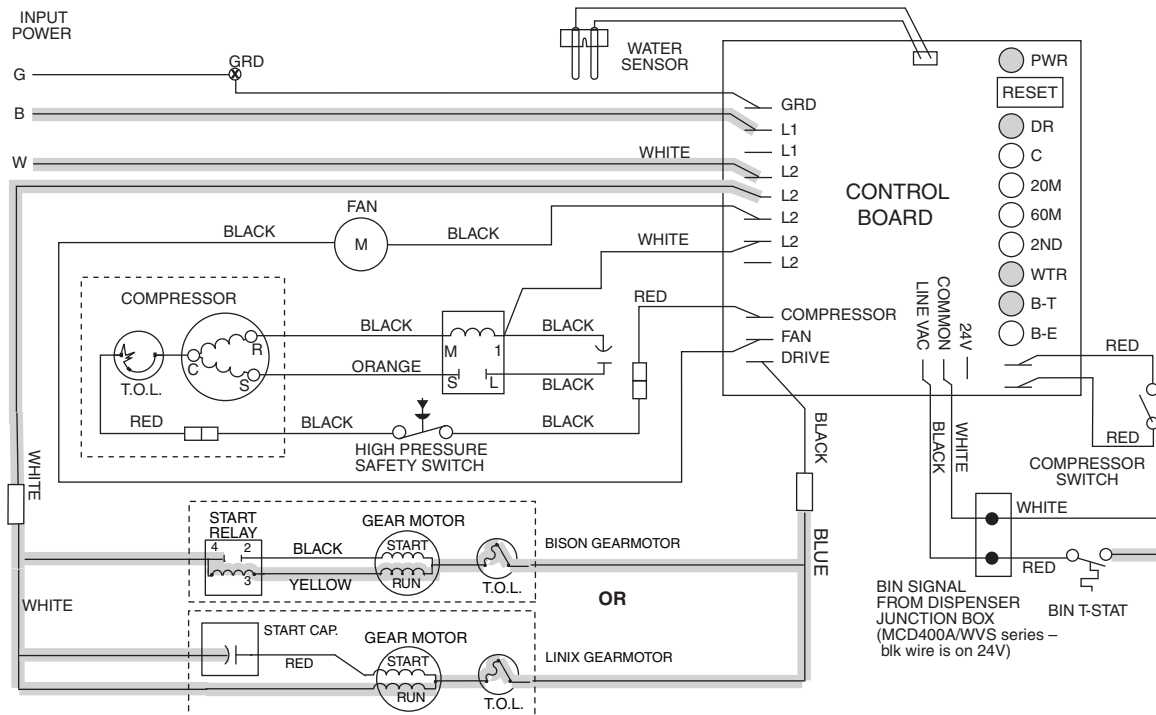

Normal operation – Stage 5

The drive motor now shuts down and the DR LED is off. The B-T LED remains on for 20 minutes. The ice machine will not start while the B-T LED is on. To restart the ice machine for troubleshooting purposes, depress the reset button to clear the control board.

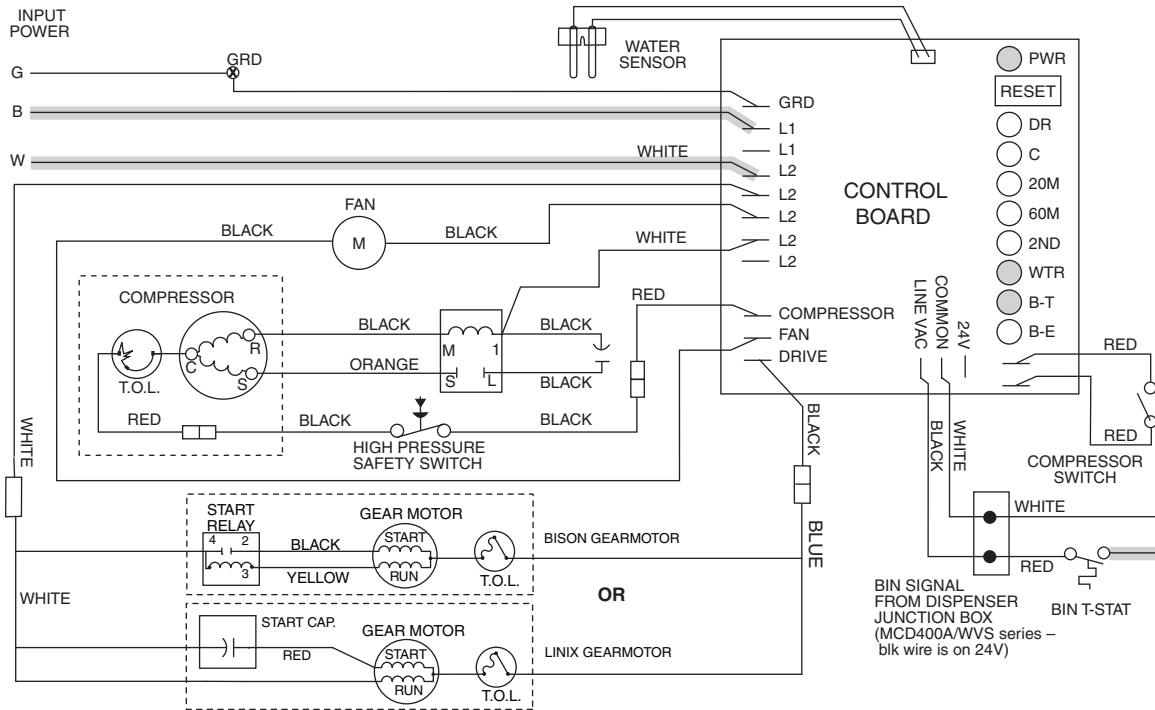

Normal operation – Stage 6

When the dwell time of 20 minutes has expired, the B-T LED goes off. The ice machine goes through the normal start-up sequence when the bin level control signals the control board for ice. The WTR LED will remain on as long as the water sensor in the float reservoir senses water.

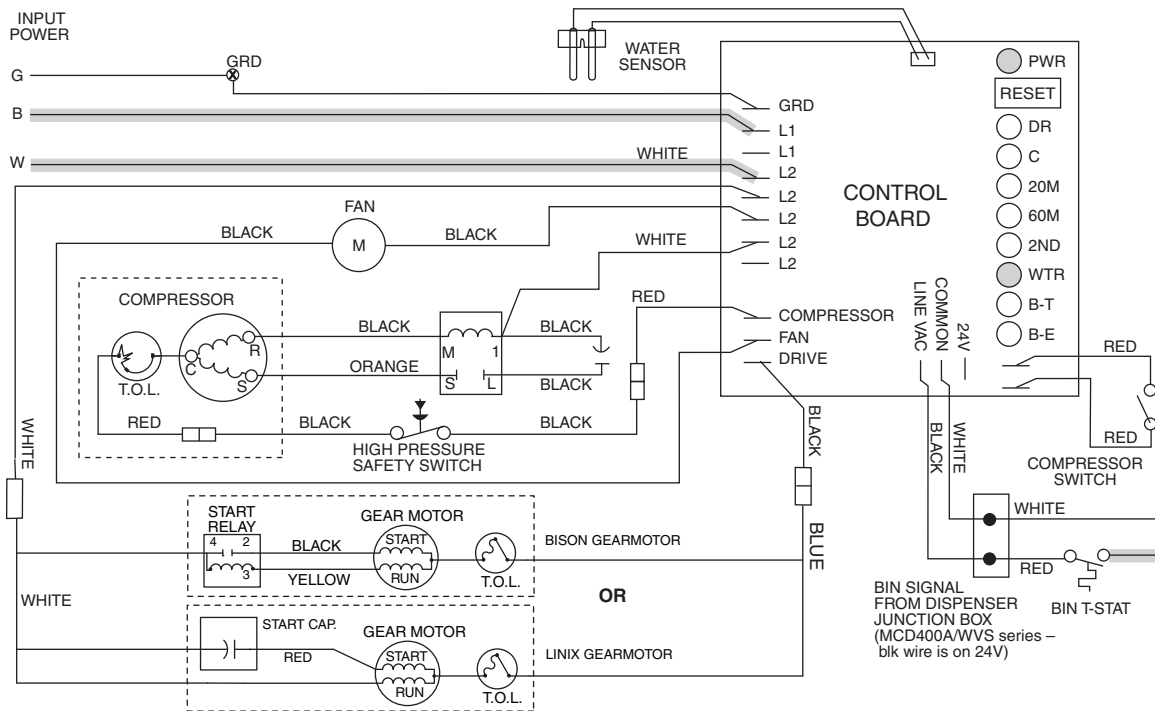

Diagnostic sequence – Stage 7

The 20 minute error LED (20M) is on, indicating that the control board has sensed an over-torque condition (above 3A on the gearmotor). The 20M LED remains on for 20 minutes after an over-torque condition has occurred. The ice machine remains off as long as the 20M LED is on. When the 20M LED goes off, the control board will try to go through a normal start-up sequence. The WTR LED remains on as long as the water sensor in the float reservoir senses water.

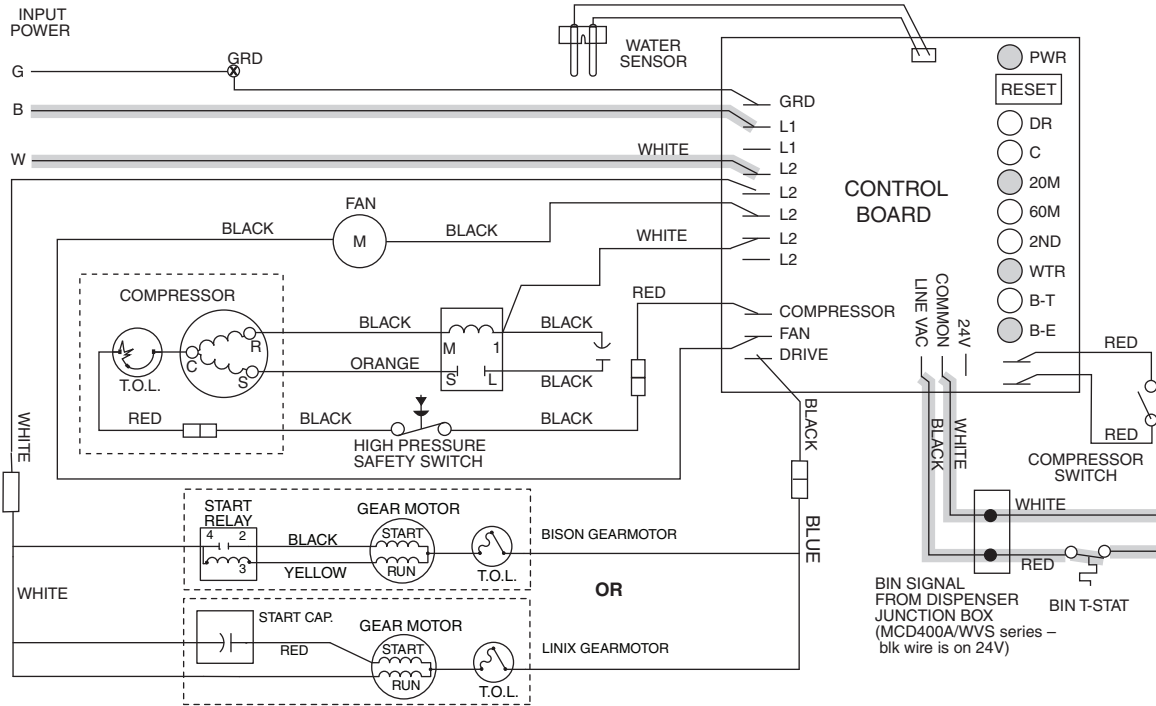

Diagnostic sequence – Stage 8

If the restart is successful the 20M LED goes off, the 60 minute timer LED (60M) comes on. The 60M LED remains on for 60 minutes from restart. A lighted 60M LED indicates that the ice machine has experienced an over-torque condition. If the ice machine runs without problems for 60 minutes and no additional torque errors occur, the 60M LED goes off and the ice machine continues normal operation.

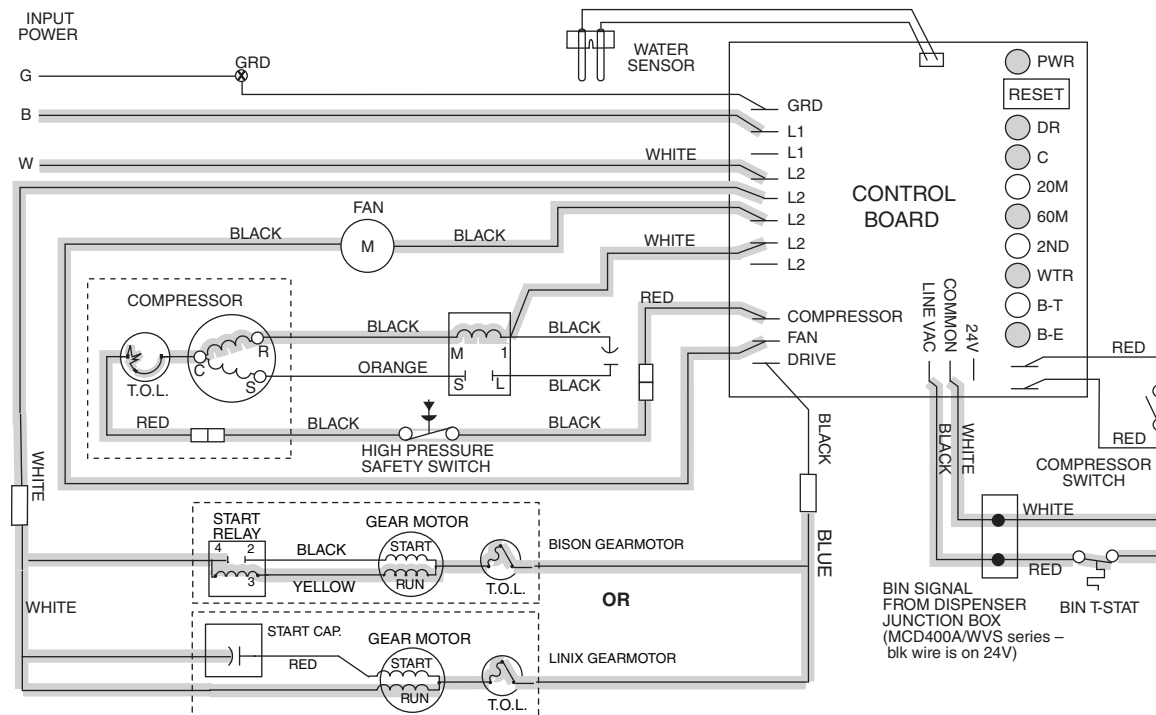

Diagnostic sequence – Stage 9

The second error (2ND) LED comes on if an over-torque condition occurs while the 60M LED is still lit. The 2ND LED indicates that two consecutive over-torque situations have occurred. The ice machine will be shut down at this time and will not restart unless the manual reset button is depressed.

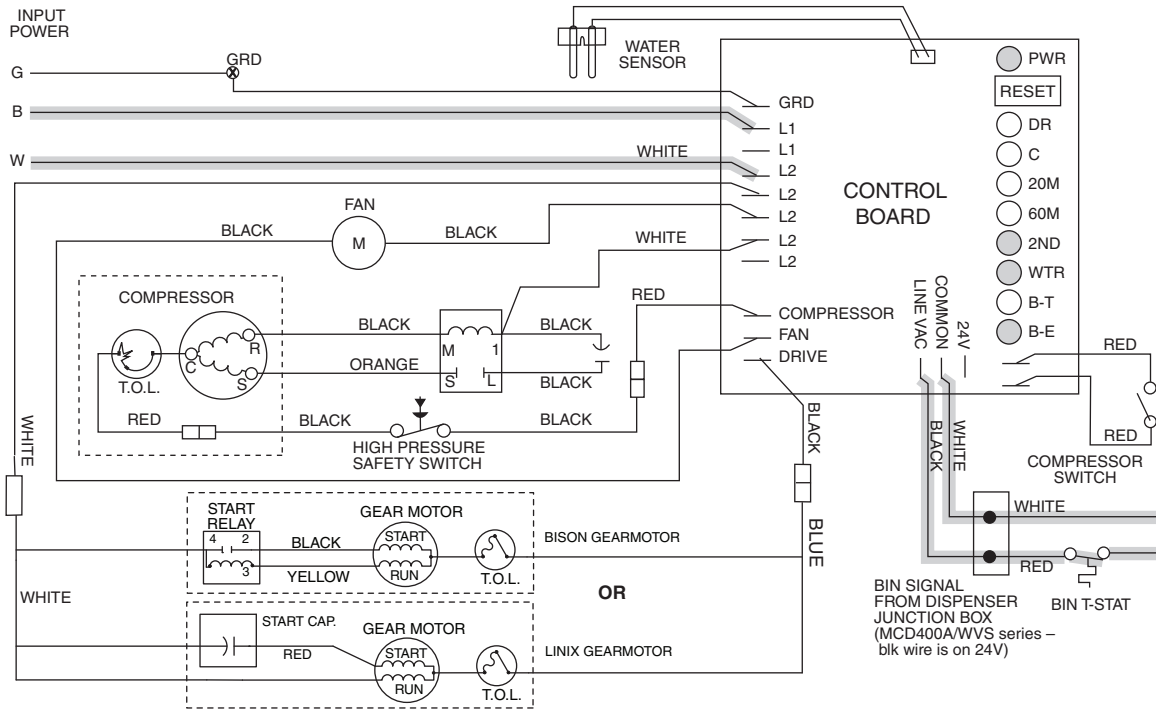

Diagnostic sequence – Stage 10

If the water level in the float reservoir drops to an unacceptable level, the WTR LED goes out, shutting the ice machine off. Also, the BT LED comes on, preventing the ice machine from restarting for twenty minutes. If water is restored, the WTR LED comes back on and flashes to alert the technician that water to ice machine has been lost. The ice machine restarts at the end of the 20 minute time delay. The flashing WTR LED can be cleared by pressing the reset button.

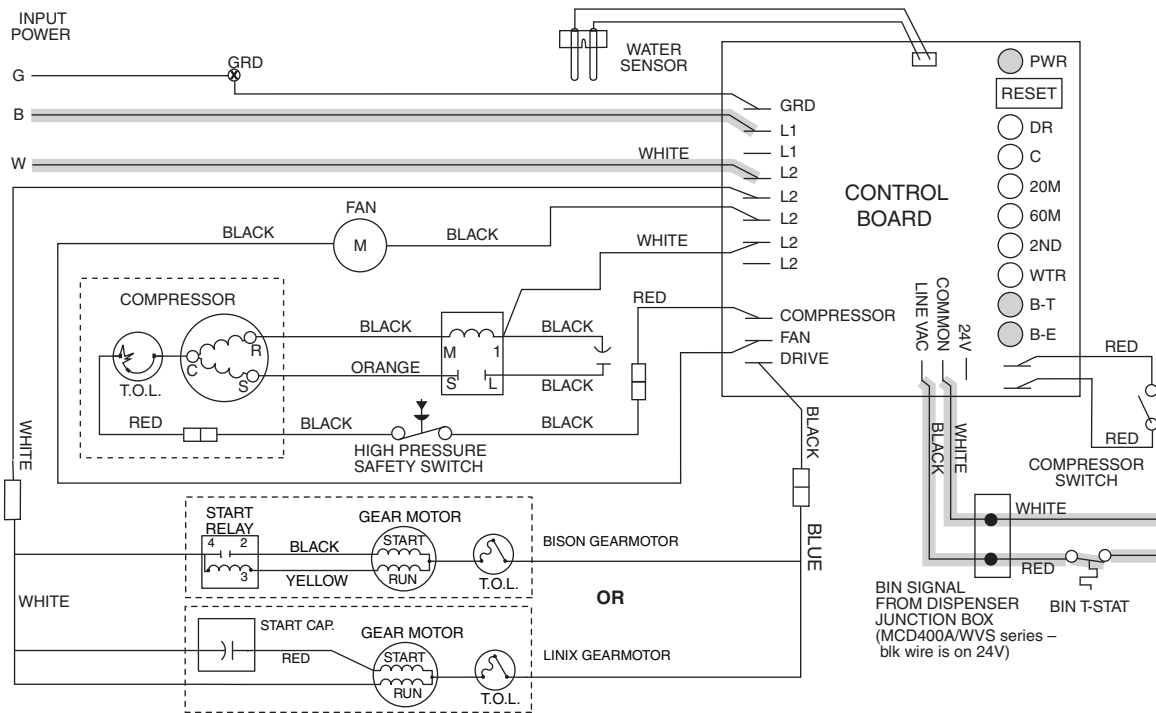

Refrigeration cycle

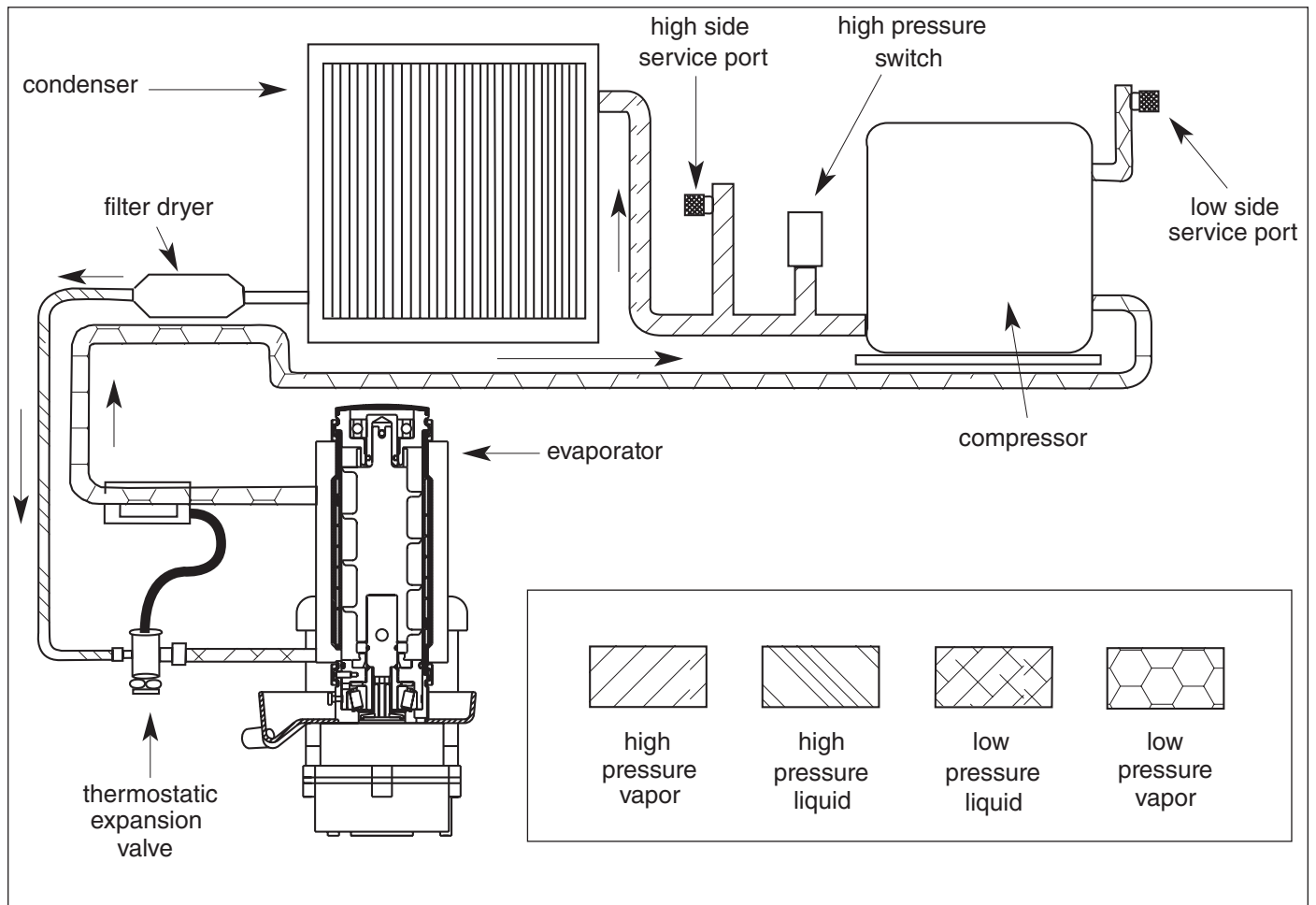

Refrigeration data

Ice production

Air-cooled icemaker capacity/24 hrs.

		Ambient Air Temperature F/C					
		F	60	70	80	90	100
Inlet Water Temperature °F/°C	C	16	21	27	32	38	
	50	425	395	360	330	295	lbs.
	10	193	180	164	150	134	kg.
	60	410	380	345	315	285	lbs.
	16	186	173	157	143	130	kg.
	70	395	365	330	300	270	lbs.
	21	180	166	150	137	123	kg.
	80	380	350	318	285	255	lbs.
	27	173	159	145	130	116	kg.
	90	365	335	305	273	243	lbs.
32	166	152	139	124	111	kg.	

Water-cooled icemaker capacity/24 hrs.

		Ambient Air Temperature F/C					
		F	60	70	80	90	100
Inlet Water Temperature °F/°C	C	16	21	27	32	38	
	50	430	425	418	390	350	lbs.
	10	195	193	190	177	159	kg.
	60	415	406	392	368	334	lbs.
	16	188	184	178	167	152	kg.
	70	401	386	365	345	318	lbs.
	21	182	175	166	156	144	kg.
	80	385	365	340	323	304	lbs.
	27	175	166	154	147	138	kg.
	90	368	343	315	300	290	lbs.
32	167	156	143	136	132	kg.	

Ice capacity test

Ice machine production capacity can only be determined by weighing ice produced in a specific time period.

1. Remove top panel and hopper lid of unit.
2. Weigh and record weight of container used to catch ice.
3. Run ice machine for at least 15 minutes.
4. Catch ice for 15 or 20 minutes.
5. Weigh harvested ice and record total weight.
6. Subtract weight of container from total weight.
7. Convert fractions of pounds to decimal equivalents (Ex. 6 lbs 8 oz = 6.5 lbs).
8. Calculate production using following formula:

$$\frac{1440 \text{ min.} \times \text{wt. of ice produced}}{\text{Total test time in minutes}} = \frac{\text{production capacity/}}{24 \text{ hr. period}}$$
9. Calculated amount per 24 hours should be checked against rated capacity for same ambient and water temperatures in Ice Production Table (above).

Compressor current draw

Air-Cooled Ambient Air Temperature					
Fahrenheit	60 F	70 F	80 F	90 F	100 F
Celsius	15.6 C	21.1 C	26.7 C	32.2 C	37.8 C
Locked Rotor Amps	58.8				

Gearmotor data

Gearmotor current	2.25A (nominal)
Locked Rotor Amps	14

Refrigeration system

Important: All service on refrigeration system must be performed in accordance with all federal, state and local laws that pertain to the use of refrigerants. It is the responsibility of the technician to ensure that these requirements are met.

CAUTION

- Recharging of unit at other than factory specifications will void ice machine warranty

Ice machine charge specifications

Model	Charge	Refrigerant Type
25/50CI400A, 25/50HI400A	20 oz	R404A
25/50CI400W	9 oz	R404A

Refrigerant replacement requirements

1. Non-contaminated refrigerant removed from any Follett refrigeration system can be recycled and returned to the same system after completing repairs. Recycled refrigerant must be stored in a clean, approved storage container. If additional refrigerant is required, virgin or reclaimed refrigerant that meets ARI standard 700-88 must be used.
2. In the event of system contamination (for example, a compressor burn out, refrigerant leak, presence of non-condensibles or moisture), the system must be repaired, evacuated and recharged using virgin or reclaimed refrigerant that meets ARI standard 700-88.
3. Follett Corporation does not approve of recovered refrigerants. Improper refrigeration servicing procedures will void the factory warranty.

Evacuation

Evacuate the system to a level of 500 microns. When the 500 micron level is reached, close valves and shut down the vacuum pump. Allow the system to sit for approximately 20 minutes. During this period the system pressure should not rise. If the system pressure rises and stabilizes there is moisture in the system and further evacuation is needed. If the pressure continues to rise check the system for leaks.

Ambients

Air Temperature ¹	Minimum	Maximum
Fahrenheit	50 F	100 F
Celsius	10 C	38 C
Water Temperature ²	Minimum	Maximum
Fahrenheit	40 F	90 F
Celsius	4 C	32 C

- 1 - Ambient air temperature is measured at the air-cooled condenser coil inlet.
 2 - Ambient water temperature is measured in the ice machine float reservoir.

Dispenser troubleshooting

Before calling for service

1. Check for ice in the ice storage area.
2. Check that congealed ice is not causing a jam.
3. Check that all switches and circuit breakers are on.
4. Check that all drains are clear.

 WARNING	
	<ul style="list-style-type: none"> • Disconnect power to unit before putting hands or arms in storage area or attempting any repair or service to equipment

Lever model troubleshooting guide

Problem	Indicators	Corrective Action
Does not dispense ice.	<ol style="list-style-type: none"> 1. Power switch off or faulty. 2. Faulty dispense switch. 3. Wheel motor malfunction. 	<ol style="list-style-type: none"> 1. Check switch – turn on or replace if faulty. 2. Replace switch. 3. Check motor and capacitor and replace
Dispense wheel rotates continuously.	Dispense switch contacts are burned out.	Replace dispense switch.
Ice machine runs continuously.	Faulty or incorrectly positioned bin stat.	Check for proper positioning. If stat does not open when ice is placed on capillary tube, replace stat.
Does not dispense water.	<ol style="list-style-type: none"> 1. Faulty water solenoid valve. 2. Faulty dispense switch. 3. Power switch off or faulty. 	<ol style="list-style-type: none"> 1. Replace water solenoid valve. 2. Replace dispense switch. 3. Check switch - turn on or replace if faulty.

SensorSAFE model troubleshooting guide

Problem	Action	SensorSAFE Board LED Status			Corrective Action
		PWR	CLN	ICE/WTR	
Does not dispense ice and/or water.	Check LEDs on the SensorSAFE control board.	OFF	OFF	OFF	Check circuit breakers and power switch. Restore power or replace defective switch.
		ON	ON	OFF	Press clean switch on lower left side of electrical enclosure to return board to normal operation.
	Place cup under drop zone (in front of lens)	ON	OFF	OFF	Troubleshoot appropriate lens/sensor and replace if required (see lens/sensor troubleshooting).
		ON	OFF	ON	Verify power on appropriate output terminal (WTR or WM) on control board and replace board if required. If board tests okay, troubleshoot appropriate dispenser component.
Dispenses ice and/or water continuously.	Check LEDs on control board.	ON	OFF	ON	Troubleshoot appropriate lens/sensor and replace if required (see lens/sensor troubleshooting).
		ON	OFF	OFF	If there is power on any output terminal (WTR or WM) on control board, replace board.

Board guide

LEDs, when illuminated, indicate the following: PWR (board power), CLN (cleaning, no dispensing cycle), ICE (ice dispensing activated), WTR (water dispensing activated).

Terminals: LI (incoming power, hot), L2 (neutral terminals), WTR (power terminal for water solenoid), WM (power terminal for wheelmotor), CLN (terminals for clean cycle switch).

Lens/sensor troubleshooting

1. Turn dispenser power switch off and remove splash panel.
2. Disconnect wires from WTR and WM terminals on board.
3. Gently remove sensor/mounting block from splash panel.
4. Inspect lens and sensor. Clean if necessary.
5. Restore dispenser power and test sensor by passing hand in front of sensor.
6. If LED on board turns on, sensor is operational. Re-assemble dispenser.
7. If LED does not come on, switch sensor leads on board and retest.
8. If opposite LED comes on, replace defective board.
9. If opposite LED does not come on, replace defective sensor.

Ice machine troubleshooting

Flashing water LED at any time indicates that water signal to board had been lost for more than one second.

Ten-second delay: There is a 10 second delay in reaction to loss of water (WTR) or bin (B-E) signals. If signals are not lost for more than 10 seconds, no reaction will occur.

Problem	Indicators	Corrective Action
Ice machine will not run. System status: compressor, gearmotor, and fan motor inoperative.	<ol style="list-style-type: none"> 1. No power to unit. 2. Open bin level control. 3. Water OK LED (WTR) not on. 4. 20M or 2ND LED is on indicating that first or second torque error has occurred. 5. Gear motor locked up (immediate torque error indicated by LEDs when board is reset). 6. Open coil on gearmotor start relay causing an immediate torque error. 	<ol style="list-style-type: none"> 1. Check that unit is plugged in, circuit breakers are on. 2. Adjust or replace ice level control. 3. Check reservoir for water, restore water to unit. 4. See #6 below. 5. Repair or replace gearmotor. 6. Replace gearmotor start relay.
Compressor will not run. System status: gearmotor and fan motor run.	<ol style="list-style-type: none"> 1. Condenser coil plugged causing open overload or high pressure cut-out. 2. Defective starting capacitor. 3. Defective starting relay. 4. Open motor winding. 5. No power output from compressor output terminal on control board. 	<ol style="list-style-type: none"> 1. Clean condenser coil and replace overload if necessary. 2. Replace start capacitor. 3. Replace relay. 4. Ohm out windings and replace compressor if necessary. 5. Check terminal connection and replace control board if necessary.
Unit cycles intermittently. System status: compressor, gearmotor, and fan motor cycle.	<ol style="list-style-type: none"> 1. Float reservoir running dry, sensing probe signalling for system to shut down. 	<ol style="list-style-type: none"> 1. Check water supply to float and float operation. PC board will have flashing WTR LED.
Low ice production. Poor quality ice.	<ol style="list-style-type: none"> 1. Dirty air filter or condenser coil. 2. Restricted air flow to condenser coil. 3. Mineral coated evaporator. 4. Improper exhaust air provisions. 5. Faulty expansion valve. 6. Low refrigerant charge. 7. Superheat incorrect. 8. Inefficient compressor. 	<ol style="list-style-type: none"> 1. Clean or replace filter, clean condenser. 2. Remove obstruction. 3. Clean evaporator. 4. Provide proper exhaust air provisions per Follett installation manual. 5. Replace expansion valve. 6. Check for leaks; repair, evacuate, and weigh in correct charge. 7. Check that TXV sensing bulb is securely clamped in place and not damaged; check that insulated bulb cover is in place. 8. Replace compressor.
Water leaks from bottom of evaporator.	<ol style="list-style-type: none"> 1. O ring seal broken. 	<ol style="list-style-type: none"> 1. Replace O ring.
Ice machine runs for short period of time and shuts down on torque error. System status: 20M or 2nd LED is lit.	<ol style="list-style-type: none"> 1. Kink in ice transport tube. 2. Bin level control remains in closed position. 3. Ice transport tube ruptured internally. 4. Worn evaporator bearings. 5. Faulty gearmotor start relay. Ice machine torques out within 5 seconds of start-up. 6. Torque out occurs when storage bin fills to capacity. 	<ol style="list-style-type: none"> 1. Eliminate kink and check that tube routing complies with Follett ice machine installation manual. 2. Adjust or replace control. 3. Replace complete length of ice transport tube. 4. Inspect bearings for roughness or binding and replace if necessary. 5. Replace gearmotor start relay. 6. Ensure that ice contacts bin thermostat before backing ice up in transport tube. Refer to dispenser manual for proper thermostat and ice tube mounting.
Evaporator is iced up on the outside. No ice production. System status: compressor, gearmotor and fan motor running.	<ol style="list-style-type: none"> 1. Gearmotor running but no output rotation. 2. Float reservoir empty. 3. Air bubble in water supply line. Water in reservoir but not in evaporator. 	<ol style="list-style-type: none"> 1. Check for broken gearmotor output shaft or damaged gearbox. 2. Check for defective water sensor (water OK (WTR) LED remains on even when float empty or probe removed from water). 3. Purge air from line.

Problem	Indicators	Corrective Action
Compressor cycles intermittently. System status: gearmotor and fan motor run.	<ol style="list-style-type: none"> 1. Compressor start relay in wrong position. 2. High pressure cutout open due to high head pressure. 3. Clogged or dirty air filter or condenser coil. 4. Improper ventilation. 5. Defective compressor. 	<ol style="list-style-type: none"> 1. Position relay with arrow or word "top?" 2. Check discharge pressure and adjust water regulator valve. 3. Clean or replace filter, clean condenser coil. 4. Provide inlet and exhaust air provisions per Follett ice machine installation manual. 5. Replace compressor.
Unit runs but not making ice. System status: compressor, gearmotor & fan motor running.	<ol style="list-style-type: none"> 1. Clogged or dirty air filter or condenser coil. 2. Compressor not pumping. 3. Low refrigerant charge. 	<ol style="list-style-type: none"> 1. Clean or replace filter, clean condenser coil. 2. Replace compressor. 3. Check for leaks; repair, evacuate, and weigh in correct charge.
Compressor and fan motor will not run. Gearmotor runs.	<ol style="list-style-type: none"> 1. Compressor switch in OFF position. 2. No output on compressor and fan motor terminals on control board. 3. Failed fan motor causes high pressure cut-out to open. 	<ol style="list-style-type: none"> 1. Turn compressor switch on. 2. Replace control board. 3. Replace fan motor.
Intermittent noises from evaporator.	<ol style="list-style-type: none"> 1. Mineral build-up on evaporator surface. 	<ol style="list-style-type: none"> 1. Clean evaporator with liquid ice machine cleaner.

Dispenser replacement parts

Dispenser exterior

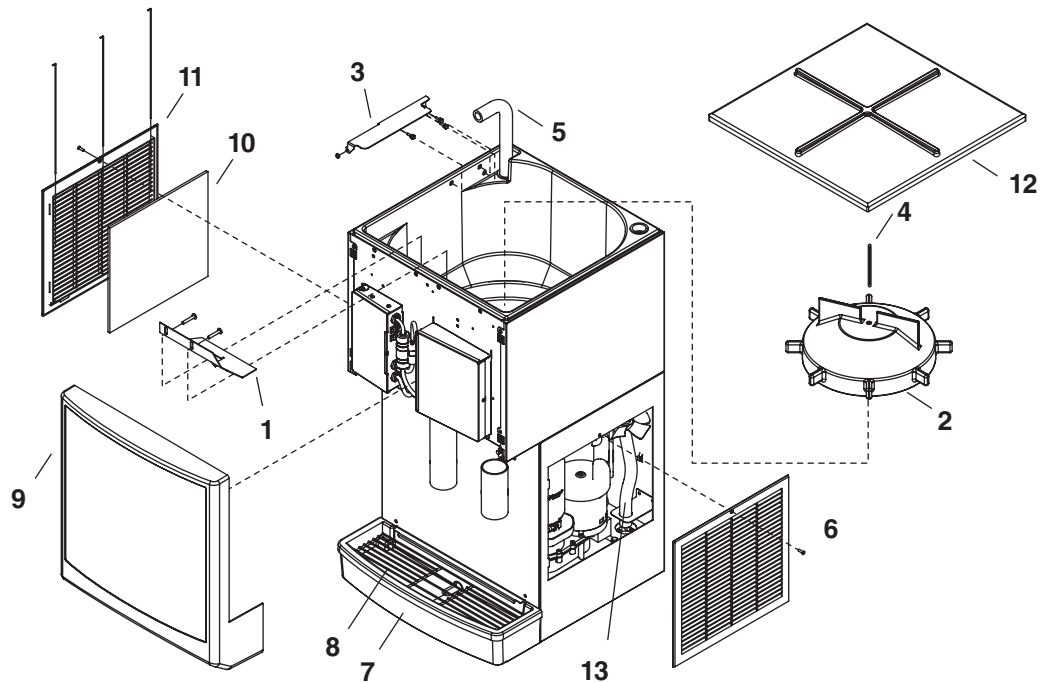

Reference	Description	Part #
1	Baffle, ice	501608
2	Wheel, dispense (includes 501612)	502821
3	Bracket, ice tube	502712
4	Rod, threaded (includes knurled nut)	501612
5	Ice transport tube, 25 series	00196030
5	Ice transport tube, 50 series	00196048
6	Louver, exhaust	00192963
7	Drain pan	502682
8	Grille	01050277
9	Cover, front 25 series	00192831
9	Cover, front 50 series	00192849
9	Cover, front 25 series, ice only	00969204
9	Cover, front 50 series, ice only	00969212
10	Air filter	00184275
11	Louver, intake (includes 00184275)	00192955
12	Lid, hopper	502684
13	Drain tube, ice storage hopper	00900142
Not shown	Drain pan protector	00195974
Not shown	Wall mount bracket and cover plate	00902080

Dispense chute and splash panel areas (lever models) — Serial Number D61292 and above

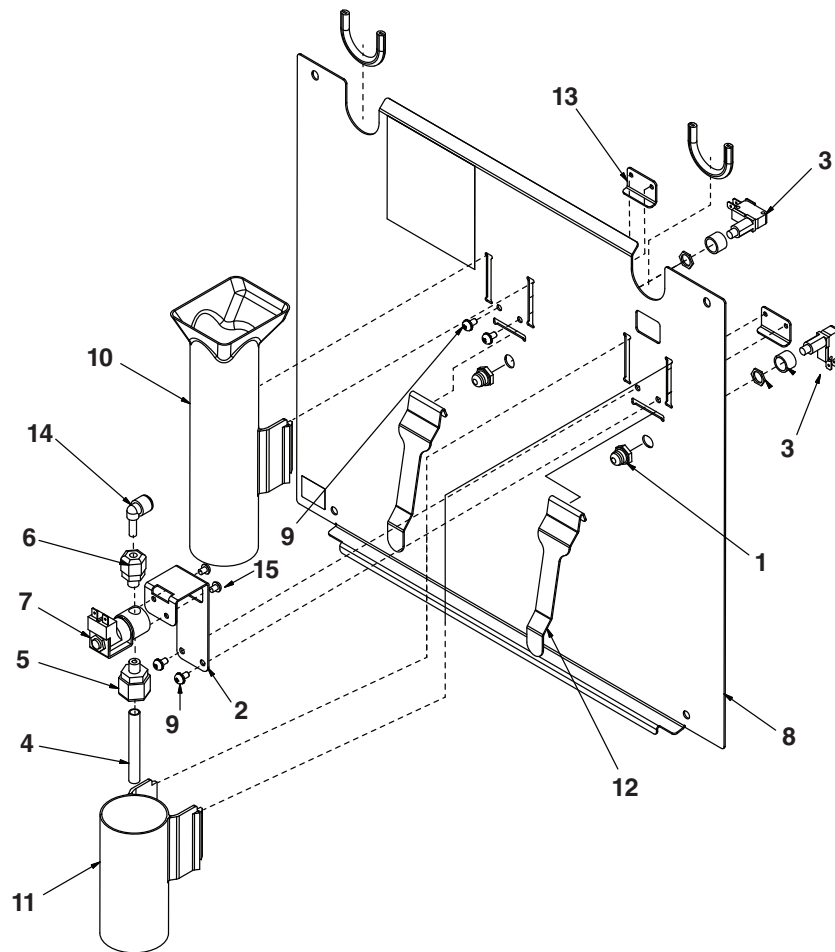

Reference	Description	Part #
1	Boot, dispense switch button (mounts on 00981217 switch)	502418
2	Bracket, water solenoid	00987875
3	Switch, dispense, ice or water, lever actuated (includes boot)	00981217
4	Tube, water station	00187682
5	Fitting, outlet, 1/8" MPT x 3/8" comp	502262
6	Fitting, inlet, 1/8" MPT x 1/4" comp	502246
7	Solenoid valve, water, 120 V, 60Hz	502243
8	Splash panel, lever dispense	00981290
8	Splash panel, lever dispense, ice only	00981308
9	Screw, bracket	00982421
10	Chute, ice (with Agion® antimicrobial product protection ¹)	00984831
11	Chute, water (with Agion)	00984898
12	Lever, dispense	00976845
13	Bracket, lever	00958793
14	Elbow, 1/4"	00121699
15	Screw, valve	203227
Not shown	Tubing, water station, thermoplastic, 1/4" OD (sold by the foot)	502079

¹ Disclaimer: Antimicrobial protection is limited to the treated components and does not treat water or ice. Agion is a registered trademark of Agion Technologies, Inc, Wakefield, MA, USA.

Dispense chute and splash panel areas (lever models) — Serial Numbers below D61292

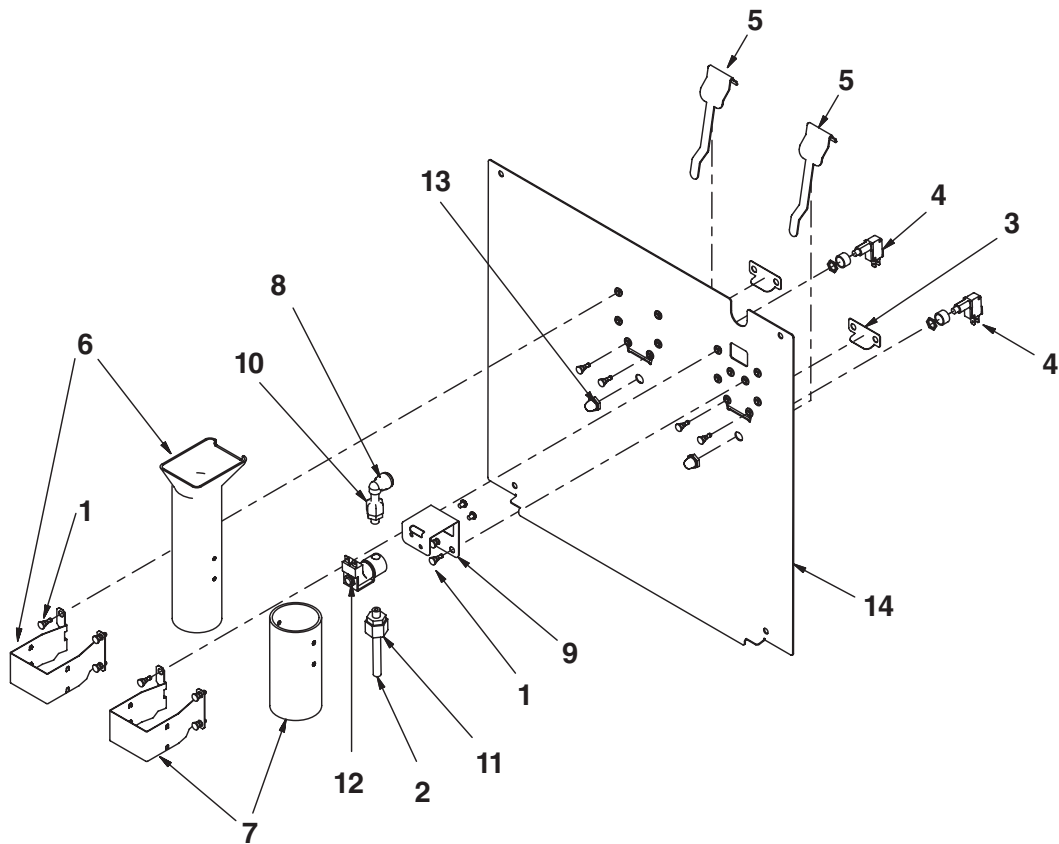

Reference	Description	Part #
1	Fastener, dispense chute bracket	502057
2	Tube, water station	00187682
3	Bracket, lever	00185116
4	Switch, dispense, ice, lever actuated (includes 502418)	502409
5	Lever, dispense	00182808
6	Chute, ice, bracket and fasteners (with Agion)	00981241
6	Chute and funnel (clear), ice	00192948
7	Chute, water, bracket and fasteners (with Agion)	00981407
7	Chute (clear), water	00184390
8	Elbow, 3/8"	502925
9	Bracket, water solenoid	00182832
10	Fitting, inlet, 1/8" MPT x 1/4" comp	502246
11	Fitting, outlet, 1/8" MPT x 3/8" comp	502262
12	Solenoid valve, water, 120 V, 60Hz	502243
13	Boot, dispense switch button (mounts on 502409 switch)	502418
Not shown	Tubing, water station, thermoplastic, 1/4" OD (sold by the foot)	502079
14	Splash panel, lever dispense	00192922
14	Splash panel, lever dispense, ice only	00969220

Dispenser electrical box – lever models

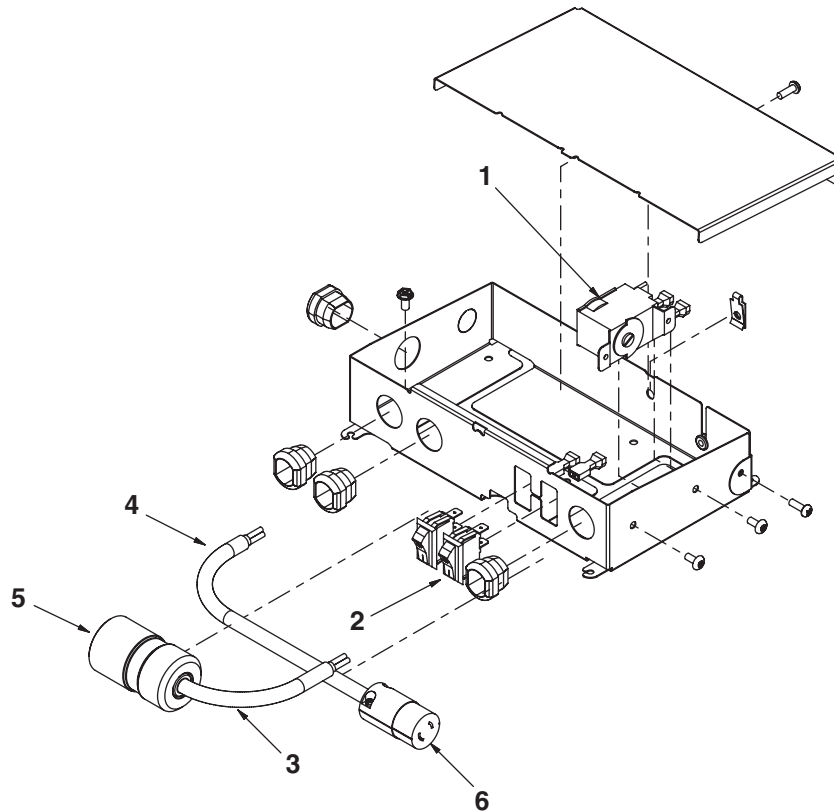

Reference	Description	Part #
1	Thermostat	500514
2	Switch, dispenser power	502209
2	Switch, ice machine bin signal	502209
3	Cord and socket (female), ice machine power	00195818
4	Cord and socket (female), bin signal	00195826
5	Socket (female), ice machine power	502336
6	Socket (female), bin signal	502334
Not shown	Power cord	502776

Dispense chute and splash panel areas (SensorSAFE models) — Serial Number D61292 and above

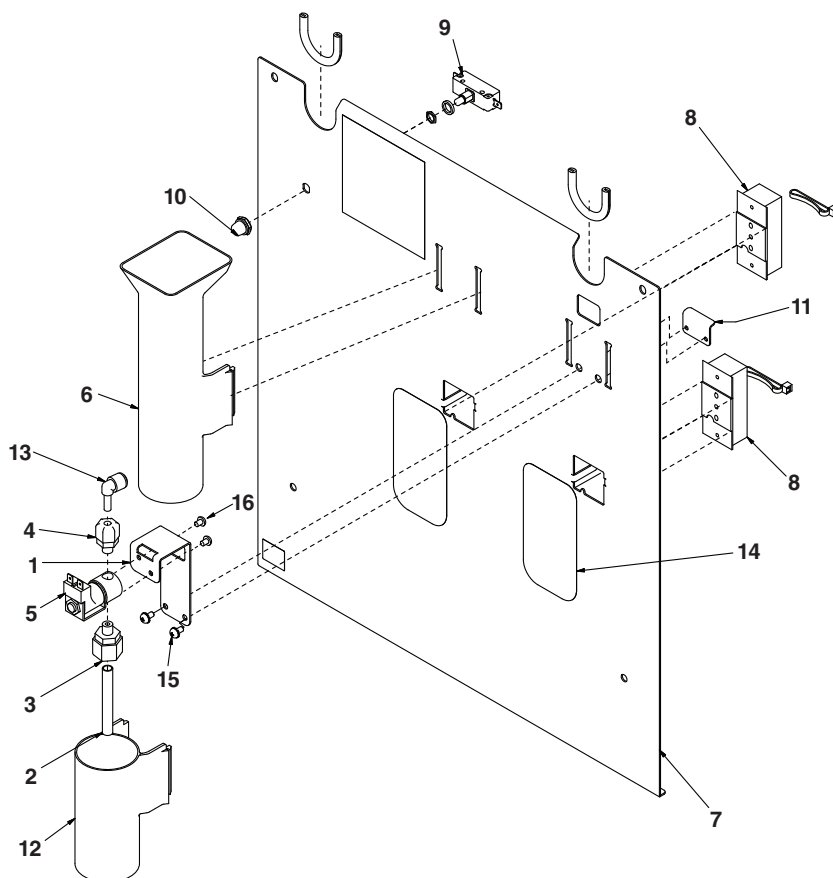

Reference	Description	Part #
1	Bracket, water solenoid	00987875
2	Tube, water station	00187682
3	Fitting, outlet, 1/8" MPT x 3/8" comp	502262
4	Fitting, inlet, 1/8" MPT x 1/4" comp	502246
5	Solenoid valve, water, 120 V, 60Hz	502243
6	Chute, ice (with Agion)	00984831
7	Splash panel, SensorSAFE dispense with drain pan (includes 2 lenses)	00981365
7	Splash panel, SensorSAFE dispense with drain pan, ice only (includes 1 lens)	00981381
7	Splash panel, SensorSAFE dispense, no drain pan (includes 2 lenses)	00981373
7	Splash panel, SensorSAFE dispense, no drain pan, ice only (includes 1 lens)	00981399
8	Sensor, ice or water dispense	00195982
9	Clean switch, SensorSAFE (includes boot)	502359
10	Boot, clean switch button (mounts on 502359 switch)	501841
11	Bracket, water valve	00958793
12	Chute, water (with Agion)	00984898
13	Elbow, 1/4"	00121699
14	Lens, sensors	00977983
15	Screw, bracket	00982421
16	Screw, valve	203227
Not shown	Tubing, water station, thermoplastic, 1/4" OD (sold by the foot)	502079

Dispense chute and splash panel areas (SensorSAFE models) — Serial Numbers below D61292

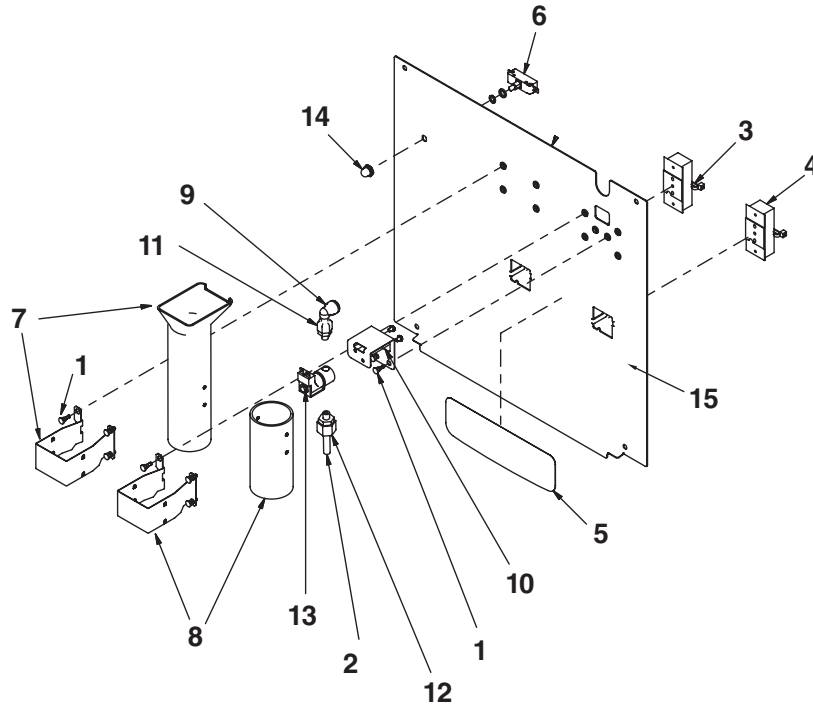

Reference	Description	Part #
1	Fastener, dispense chute bracket	502057
2	Tube, water station	00187682
3	Sensor, ice dispense	00195982
4	Sensor, water dispense	00195982
5	Lens, sensors	00196006
6	Clean switch, SensorSAFE (includes 501841)	502359
7	Chute, ice, bracket and fasteners (with Agion)	00981241
7	Chute and funnel (clear), ice	00192948
8	Chute, water, bracket and fasteners (with Agion)	00981407
8	Chute (clear), water	00184390
9	Elbow, 3/8"	502925
10	Bracket, water solenoid	00182832
11	Fitting, inlet, 1/8" MPT x 1/4" comp	502246
12	Fitting, outlet, 1/8" MPT x 3/8" comp	502262
13	Solenoid valve, water, 120 V, 60Hz	502243
14	Boot, clean switch button (mounts on 502359 switch)	501841
Not shown	Tubing, water station, thermoplastic, 1/4" OD (sold by the foot)	502079
15	Splash panel, SensorSAFE dispense with drain pan (includes 00196006)	00192930
15	Splash panel, SensorSAFE dispense with drain pan, ice only (includes 00196006)	00969238
15	Splash panel, SensorSAFE dispense, no drain pan (includes 00196006)	00902072
15	Splash panel, SensorSAFE dispense, no drain pan, ice only (includes 00196006)	00969246

Dispenser electrical box – SensorSAFE models

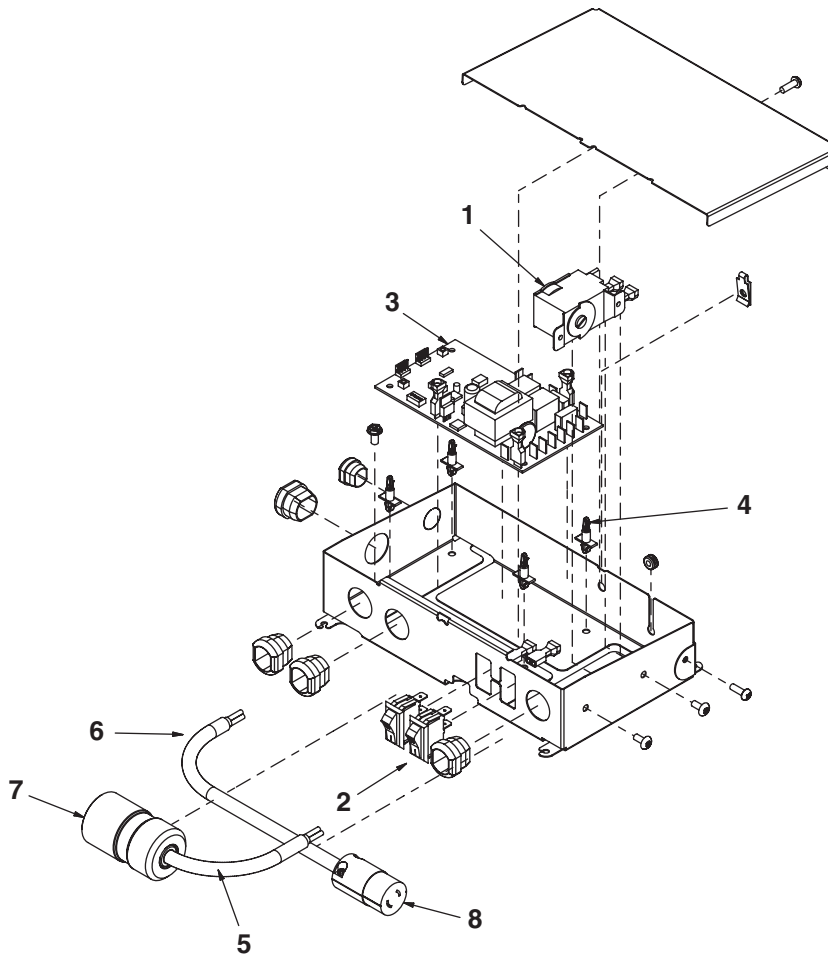

Reference	Description	Part #
1	Thermostat	500514
2	Switch, dispenser power	502209
2	Switch, ice machine bin signal	502209
3	Board, SensorSAFE	502242
4	Standoff, board (4 required)	501959
5	Cord and socket (female), ice machine power	00195818
6	Cord and socket (female), bin signal	00195826
7	Socket (female), ice machine power	502336
8	Socket (female), bin signal	502334
Not shown	Power cord	502776

Wheel motor and drive system

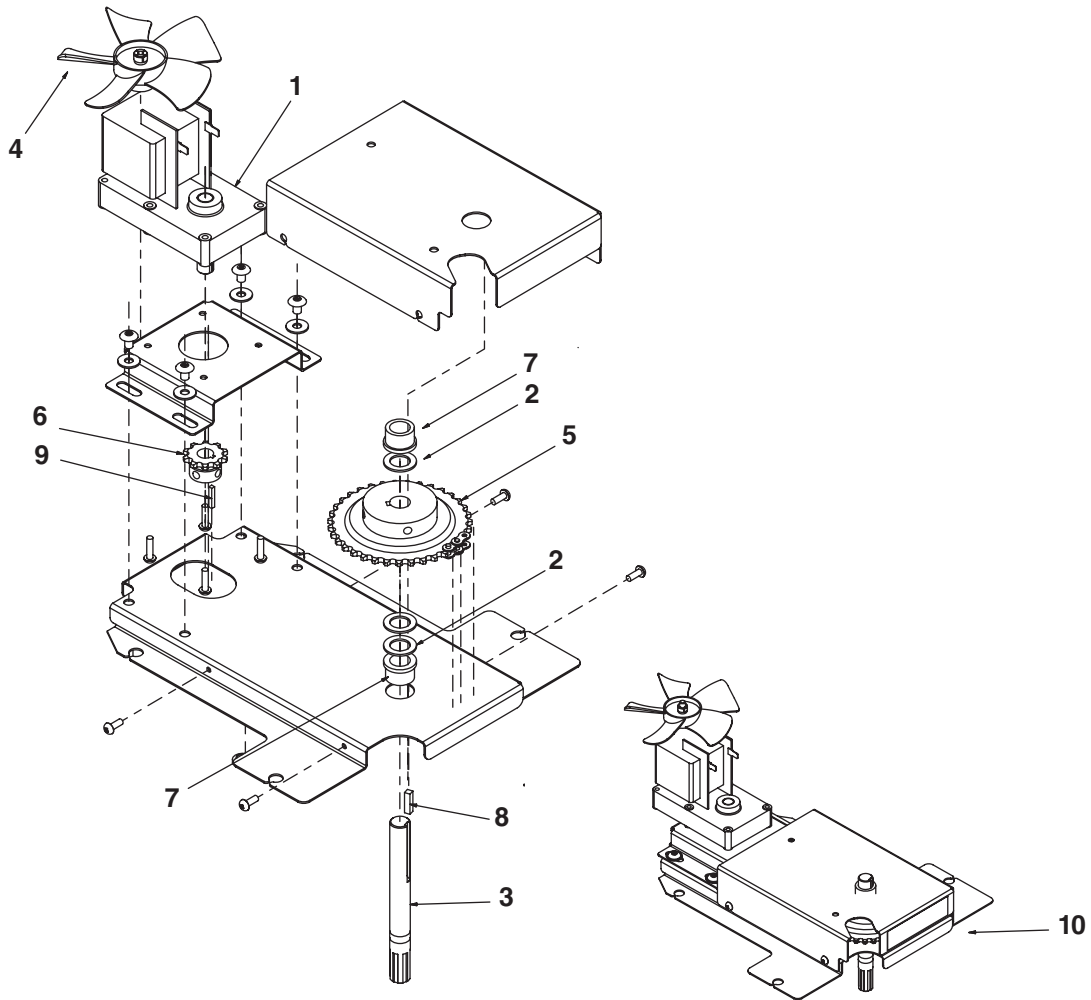

Reference	Description	Part #
1	Wheel motor, 120V, 60Hz	501861
2	Washer, thrust	501026
3	Shaft, drive (includes key and stud)	501619
4	Fan blade, wheel motor	501607
Not shown	Chain, pitch 64, link	00168781
5	Sprocket, drive shaft, 35T (includes drive shaft key)	502692
6	Sprocket, wheel motor, 10T	501019
7	Bearing, drive shaft	501024
Not shown	Connecting link, chain	500799
8	Key, drive shaft	500367
9	Key, wheel motor	205991
10	Dispenser drive assembly (parts 1-9 above)	00192971

Water and drain

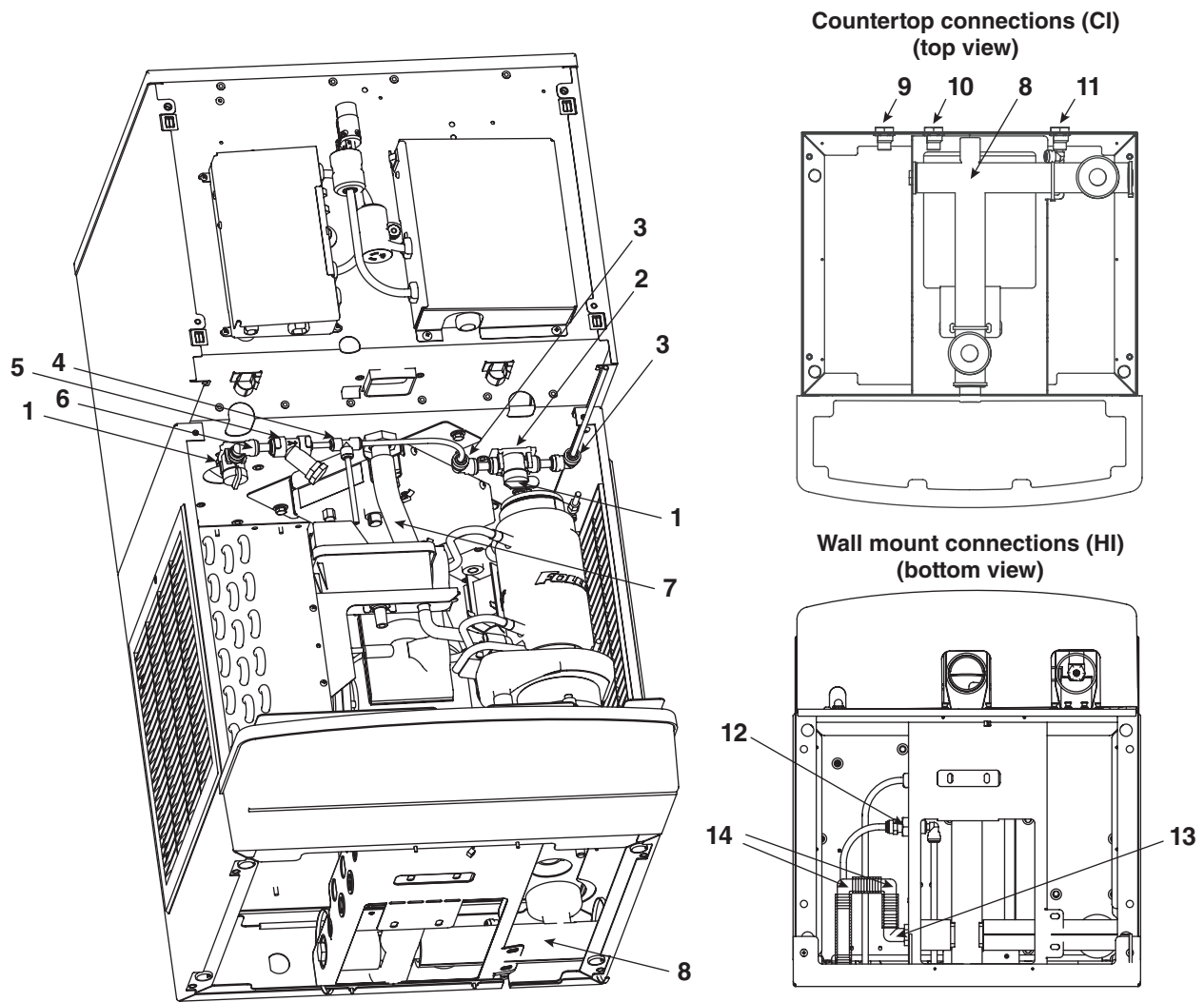

Reference	Description	Part #
1	Valve, water shut off	502921
2	Clip, shut off valve	502922
3	Elbow, 1/4" x 3/8"	00134502
4	Tee, 1/4"	502923
5	Strainer	502920
6	Elbow, 3/8"	502925
7	Drain tube, hopper	00184549
8	Drain, waste	00195958
9	Fitting, water-cooled condenser inlet	00195966
10	Fitting, water-cooled condenser outlet	00195966
11	Fitting, ice machine water inlet	00137315
12	Fitting, 3/8" tube X 3/8" MPT	00901652
Not shown	Fitting, 3/8" tube X 1/2" MPT	00901660
13	Fitting, 90° elbow, 3/4" barb X 3/4" MPT	00901678
Not shown	Bottom cover, 25/50HI with drain pan	00196113
Not shown	Bottom cover, 25/50HI without drain pain	00198341
14	Fitting, 90° elbow, 3/4" barb X 3/4" barb	00145144

Ice machine replacement parts

Evaporator

Reference	Description	Part #
1	Coupling, vee band, includes nut	502735
2	Bearing assembly, top	502736
3	Loop, ice compression, beveled	502110
4	Auger	502737
5	Evaporator (includes insulation jacket, 502740)	502725
6	O ring, bearing housing	500496
7	Bearing assembly, bottom (includes O rings and condensate shield)	502738
8	O ring, mounting base	501063
9	Shield, condensate	500744
10	Screw, Allen 1/4 20 x 1/2 (set of 4)	501080
11	Mounting base, evaporator (includes 501063)	502733
12	Bolt, mounting base	502227
13	Gearbox & motor assembly	502730
Not shown	Mounting base, gearbox	00164046
15	Compression nozzle, with single drain	502221
16	Drain pan, evaporator (includes 00185421)	00192914
17	Clamp, compression nozzle and screw	502226
18	Tubing, compression nozzle drain(s) (sold by foot)	500680
Not shown	Grease, Mobil FM 222, 14oz	501111
19	Bracket, drain hose	502739
20	Insulation jacket, evaporator	502740
Not shown	Relay, start, gearmotor	502742
Not shown	Oil, gearmotor (1 pint)	502775
Not shown	Tube, evaporator drain	00901439

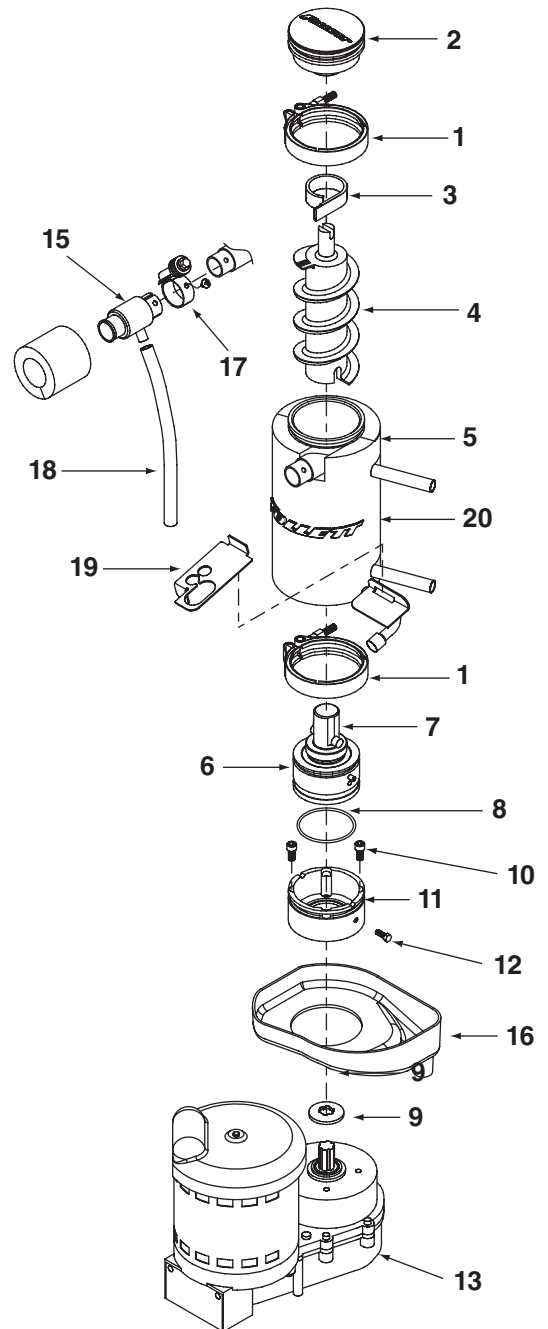

Air-cooled ice machines

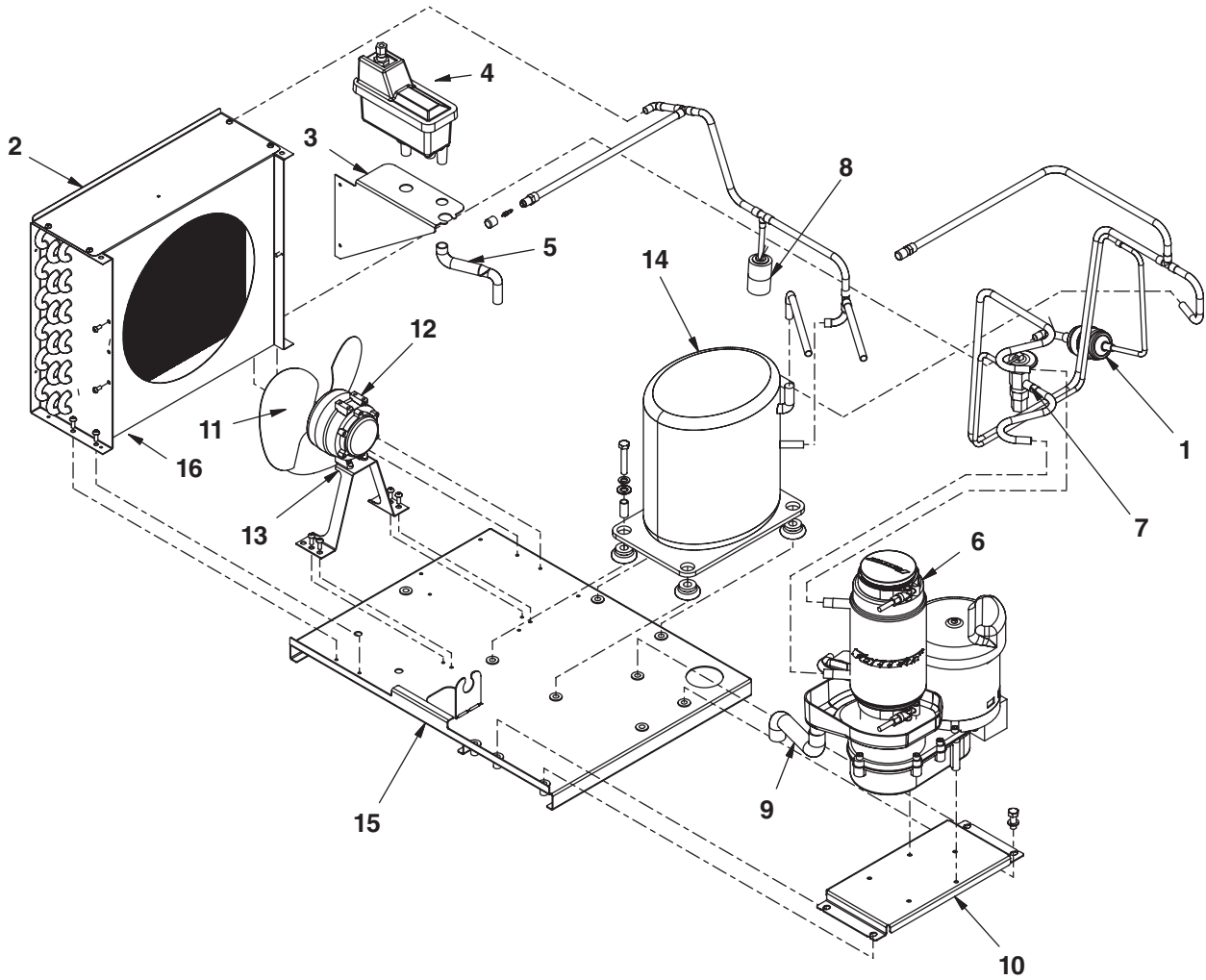

Reference	Description	Part #
1	Drier	502724
2	Condenser coil, air-cooled	00195917
Not shown	Water sensor	502116
3	Reservoir mounting bracket	00163824
4	Float valve & reservoir	500504
5	Reservoir overflow tube with Agion	00187187
Not shown	Drain kit with Agion, evaporator	00141440
6	Evaporator (see page 41 for complete breakdown)	
Not shown	Tubing, polypropylene, reservoir supply (sold by foot)	502079
Not shown	Fitting, plastic, float valve (includes sleeve & stem)	502078
7	Valve, expansion, thermal (includes 502830 and 00106534)	502726
8	High pressure cutout	502732
9	Tubing with Agion, evaporator drain	00185421
10	Mounting bracket, gearbox	00164046
11	Fan blade	500474
12	Motor, fan, 115 V, 60 Hz	500672
13	Bracket, fan motor	501188
Not shown	Overload, compressor, 115 V, 60 Hz	502782
14	Compressor, 115 V, 60 Hz	502731
15	Base, ice machine	00192989
16	Shroud, condenser coil	00195925
Not shown	Jacket, insulation, TXV	502830
Not shown	Jacket, insulation, TXV bulb	00106534
Not shown	Pinch clamp	00988238

Water-cooled ice machines

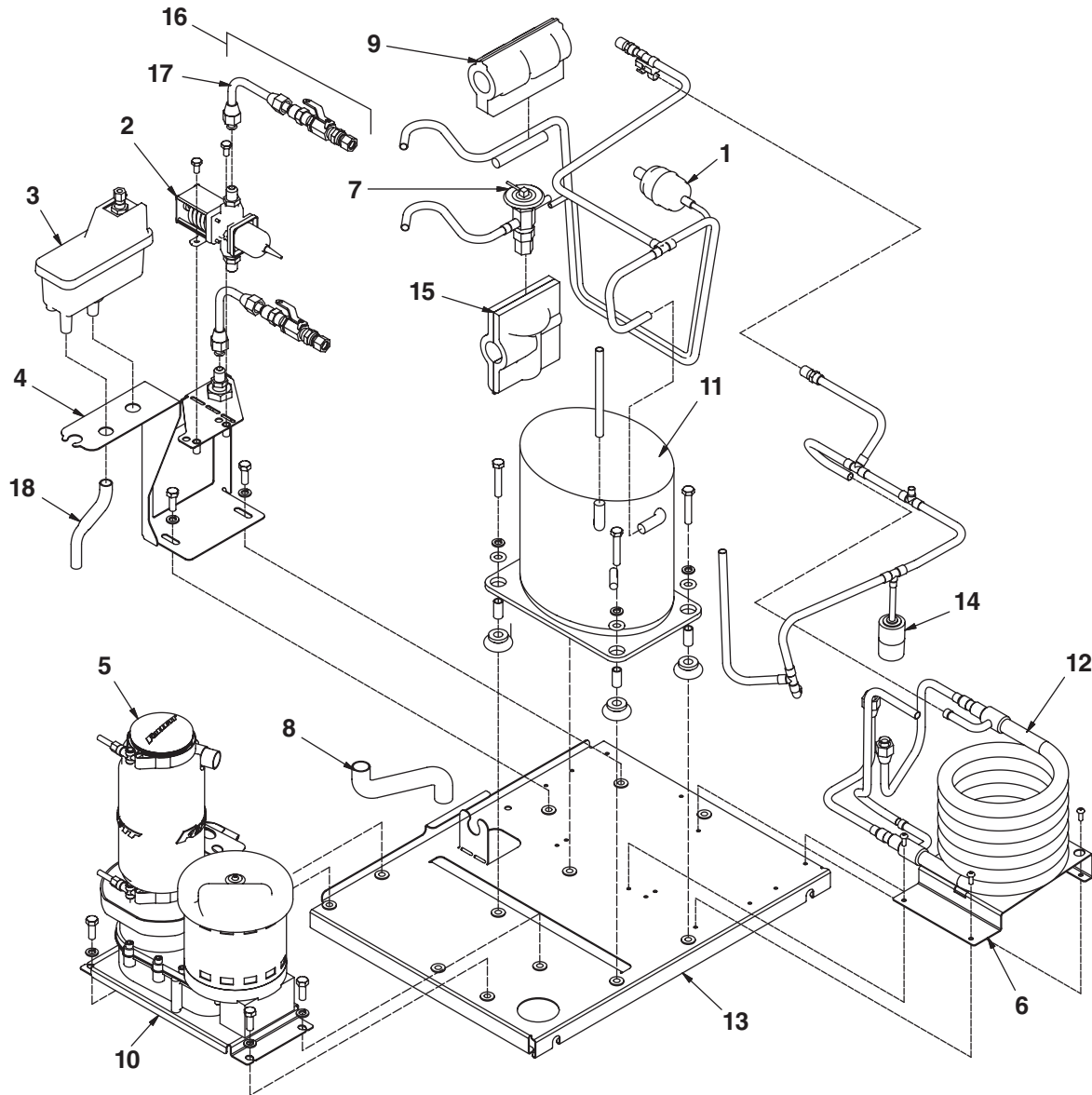

Reference	Description	Part #
1	Drier	502724
2	Valve, water regulating (includes 501810)	500537
Not shown	Iso-washer (for water regulating valve)	501810
Not shown	Water sensor	502116
3	Float valve & reservoir	500504
4	Reservoir mounting bracket	00195941
Not shown	Tubing, polypropylene, reservoir supply (sold by foot)	502079
Not shown	Fitting, plastic, float valve (includes sleeve & stem)	502078
5	Evaporator (see page 43 for complete breakdown)	502790
Not shown	Drain kit with Agion, evaporator	00141440
6	Bracket, water-cooled condenser	00176149
7	Valve, expansion, thermal (includes 502830 and 00106534)	502726
8	Tubing with Agion, evaporator drain	00185421
9	Jacket, insulation, TXV bulb	00106534
10	Mounting bracket, gearbox	00164046
Not shown	Overload compressor, 115 V, 60 Hz	502782
11	Compressor, 115 V, 60 Hz	502731
12	Coil, condenser	00195933
13	Base, ice machine	00192989
14	High pressure cutout	502732
15	Jacket, insulation, TXV	502830
16	Line set, water-cooled condenser (2 required) (includes 00187211 and 00196097)	00196089
Not shown	Water hose, 3/8" compression x 48"	00187211
17	Elbow, ice machine water connection	00196097
18	Reservoir overflow tube with Agion	00187187
Not shown	Pinch clamp	00988238

Ice machine electrical components

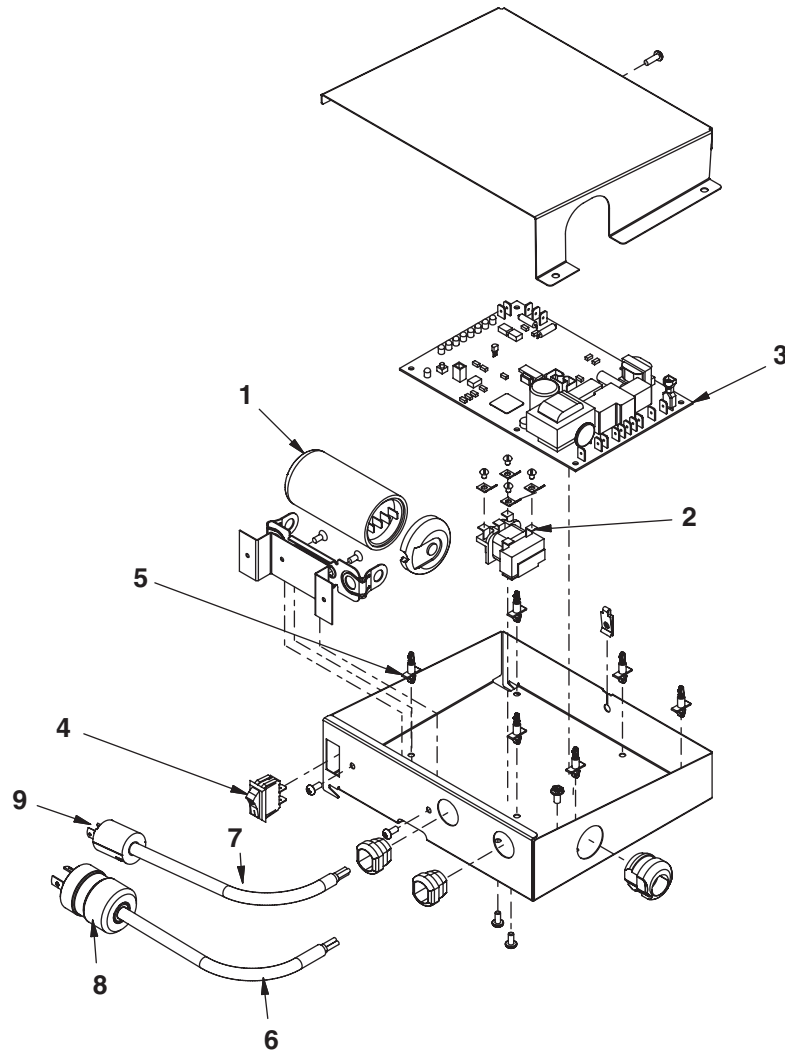

Reference	Description	Part #
1	Capacitor, start, compressor, 115 V, 60 Hz	502780
2	Relay start, compressor, 115 V, 60 Hz	501588
3	Board, control circuit, 115 V, 60 Hz	502331
Not shown	Water sensor	502116
4	Switch, on/off, compressor	502392
5	Board, stand off control (4 required)	501959
6	Cord and plug (male), ice machine power	00195834
7	Cord and plug (male), bin signal	00195842
8	Plug (male), ice machine power	502235
9	Plug (male), bin signal	502233

Water treatment accessories for Symphony ice and water dispensers

Reference #	Description	Part #
Standard capacity filter system		
Not shown	Follett QC4-FL4S water filter system (includes FL4S primary cartridge and head, coarse pre-filter and head, pressure gauge, flushing valve; assembled and installed on mounting bracket), one per ice machine	00130229
Not shown	Follett FL4S primary replacement cartridge	00130245
Not shown	Water filter cartridge – primary, carton of 6	00954297
Not shown	Everpure coarse pre-filter cartridge	00130211
Not shown	Water pre-filter cartridge – pre-filter, carton of 12	00954305
High capacity filter system		
Not shown	High capacity water filter system (one per ice machine)	00978957
Not shown	High capacity water filter cartridge – primary, single	00978965
Not shown	High capacity water filter cartridge – primary, carton of 6	00978973
Not shown	Water pre-filter cartridge – pre-filter, single	00130211
Not shown	Water pre-filter cartridge – pre-filter, carton of 12	00954305
Carbonless high capacity filter system		
Not shown	Carbonless high capacity water filter system (one per ice machine) – Horizon and Maestro series ice machines	01050442
Not shown	Carbonless high capacity water filter cartridge – primary, single	01050426
Not shown	Carbonless high capacity water filter cartridge – primary, carton of 6	01050434
Not shown	Water pre-filter cartridge – pre-filter, single	00130211
Not shown	Water pre-filter cartridge – pre-filter, carton of 12	00954305
Other filtration		
Not shown	Claris hardness removal filtration system	00986059
Not shown	Replacement filter for Claris system	00985127
Not shown	Reverse osmosis system, 200 gallons per day	00986034
Not shown	Replacement reverse osmosis cartridge	00985085
Not shown	Replacement reverse osmosis pre-filter	00985077
Not shown	Cleaning plug for reverse osmosis system	00985119
Not shown	Cleaning cartridge for reverse osmosis system	00985101
Water pressure		
Not shown	Water pressure regulator (25 psi)	501781

SafeCLEAN, SensorSAFE and Symphony are trademarks of Follett Corporation.
Follett and RIDE are registered trademarks of Follett Corporation, registered in the US.
Follett reserves the right to change specifications at any time without obligation. Certifications may vary depending on country of origin.



801 Church Lane • Easton, PA 18040, USA
Toll free (877) 612-5086 • +1 (610) 252-7301
www.follettice.com



00187153R12
© Follett Corporation 6/15