

HCD/HMD/HCF/HMF1400R, HCD/HMD1400N Ice Machines

Order parts online
www.follettice.com

Operation and Service Manual
Serial Number C33985 to C37309

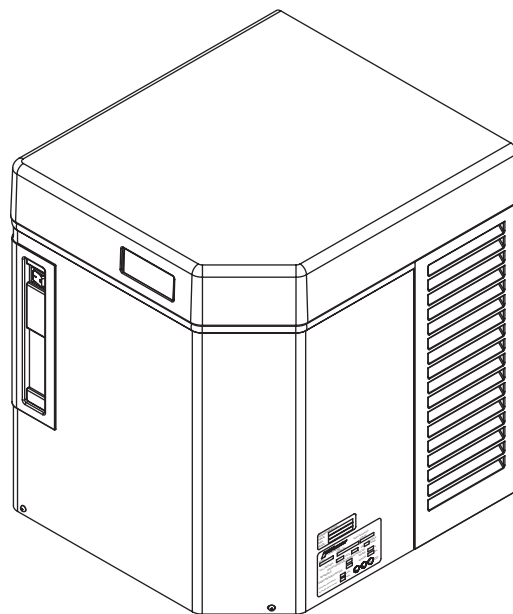

**Following installation, please forward this manual
to the appropriate operations person.**

Table of contents

| | |
|---|-----------|
| Welcome to Follett Corporation | 4 |
| Specifications | 5 |
| Operation..... | 7 |
| Cleaning, weekly exterior care | 7 |
| Cleaning, semi-annual evaporator cleaning | 7 |
| Service..... | 12 |
| Ice machine operation..... | 12 |
| Water system..... | 13 |
| Electrical system | 14 |
| Normal control board operation..... | 14 |
| Test points | 15 |
| Error faults..... | 15 |
| Hard errors | 15 |
| Soft errors..... | 15 |
| Relay output indication | 15 |
| Compressor/refrigerant solenoid output..... | 15 |
| Wiring diagram, evaporator unit | 16 |
| Wiring diagram, condenser unit | 17 |
| Gearmotor data | 17 |
| Mechanical system..... | 18 |
| Evaporator disassembly | 18 |
| Evaporator reassembly..... | 20 |
| Refrigeration system | 23 |
| Condenser unit operation..... | 23 |
| Refrigerant pressure data..... | 23 |
| Refrigerant charges..... | 23 |
| Refrigeration system diagram..... | 24 |
| Refrigerant replacement requirements..... | 25 |
| Evacuation..... | 25 |
| Ambients (evaporator unit) | 25 |
| Ice capacity test | 25 |
| Bin full detection system | 26 |
| Troubleshooting | 27 |
| Replacement parts..... | 30 |

Welcome to Follett

Follett equipment enjoys a well-deserved reputation for excellent performance, long-term reliability and outstanding after-the-sale support. To ensure that this equipment delivers the same degree of service, we ask that you review the installation manual (provided as a separate document) before beginning to install the unit. Our instructions are designed to help you achieve a trouble-free installation. Should you have any questions or require technical help at any time, please call our technical service group at (877) 612-5086 or +1 (610) 252-7301.

Before you begin

After uncrating and removing all packing material, inspect the equipment for concealed shipping damage. If damage is found, notify the shipper immediately and contact Follett Corporation so that we can help in the filing of a claim, if necessary.

Check your paperwork to determine which model you have. Follett model numbers are designed to provide information about the type and capacity of Follett equipment. Following is an explanation of the different model numbers in the 1400 series.

Chewblet® Ice Icemaker Model Number Configurations

HC
D
1400
R
V
S

| Icemaker | Voltage | Series | Condenser | Application | Configuration |
|--|---|-----------------------------------|--|---|--|
| MC Maestro™ Chewblet (400 Series) | C 208-230/60/1 (icemaking head) <i>Self-contained only.</i> | 400 up to 454 lbs (206kg) | A Air-cooled, self-contained | V Vision™ | S RIDE® <i>(RIDE remote ice delivery equipment)</i> |
| | D 115/60/1 (icemaking head) <i>Self-contained and remote.</i> | 1000 up to 1036 lbs (471kg) | W Water-cooled, self-contained | H Harmony™ | |
| HC Horizon Chewblet (1000, 1400, 1650 Series) | E 230/50/1 (icemaking head) <i>Self-contained only.</i> | 1400 up to 1450 lbs (658kg) | R Air-cooled, remote condensing unit | B Ice storage bin | T Top-mount |
| | F 115/60/1 (icemaking head) <i>Remote only. High side is 208-230/60/3.</i> | 1650 up to 1580 lbs (717kg) | N Air-cooled, no condensing unit for connection to parallel rack system | J Drop-in M Ice Manager™ diverter valve system | |
| HM Horizon Micro Chewblet | | | | | |

CAUTION

- Moving parts. Do not operate with front cover removed.
- Hot parts. Do not operate with cover removed.
- To reduce risk of shock, disconnect power before servicing.
- Most ice machine cleaners contain citric or phosphoric acid, which can cause skin irritation. Read caution label on product and follow instructions carefully.
- Ice is slippery. Maintain counters and floors around dispenser in a clean and ice-free condition.
- Ice is food. Follow recommended cleaning instructions to maintain cleanliness of delivered ice.

Specifications

Electrical

Separate circuit and equipment ground required.

Evaporator unit

Standard electrical – 115/60/1

Maximum fuse – 15A

Amperage – 6A

Condensing unit

| | Single-Phase | 3-Phase |
|------------------------------------|------------------|------------------|
| Electrical | 208-230 V, 60 Hz | 208-230 V, 60 Hz |
| Maximum Circuit HVACR breaker size | 30A | 25A |
| Minimum Circuit Ampacity | 20.0A | 14.0A |

Evaporator plumbing

3/8" OD push-in water inlet

3/4" MPT

Notes: 3/4" vented drain line must slope a minimum of 1/4" per ft (6 mm per 30.4 cm run).

Drain to be hard piped and insulated.

Water shut-off recommended within 10 ft (3 m).

Follett recommends installation of Follett water filter system (P/N 00130286) in ice machine inlet water line.

Ambient

Evaporator unit

Air temperature 100 F/38 C max.

50 F/10 C min.

Water temperature 90 F/32 C max.

45 F/7 C min.

Water pressure 70 psi max. (483 kPa)

10 psi min. (69 kPa)

Condenser unit

Air temperature 120 F/49 C max.

-20 F/-29 C min.

Refrigeration

3/8" liquid line – insulated

5/8" suction line – insulated

Note: Rack system installations require a reserve capacity of 10,000 BTU/hr at 0 F (-18 C) evaporator temperature.

Evaporator pressure regulator (not supplied) is required.

Weight

Evaporator unit

190 lb (88 kg)

Condenser unit

Single-phase: 330 lb (150 kg)

3-phase: 320 lb (145 kg)

Ice production

Ice machine capacity/24 hrs.

| | | Ambient Air Temperature F/C | | | | | |
|-----------------------------|-----|-----------------------------|------|------|-------------|------|-----|
| | | F | 60 | 70 | 80 | 90 | 100 |
| Inlet Water Temperature F/C | C | 16 | 21 | 27 | 32 | 38 | |
| | 50 | 1354 | 1333 | 1260 | 1243 | 1227 | lbs |
| | 10 | 614 | 605 | 571 | 564 | 556 | kg |
| | 60 | 1293 | 1272 | 1225 | 1208 | 1192 | lbs |
| | 16 | 586 | 577 | 556 | 548 | 541 | kg |
| | 70 | 1229 | 1208 | 1190 | 1172 | 1157 | lbs |
| | 21 | 557 | 548 | 540 | 532 | 525 | kg |
| | 80 | 1167 | 1146 | 1102 | 1084 | 1069 | lbs |
| | 27 | 529 | 520 | 500 | 492 | 485 | kg |
| | 90 | 1107 | 1060 | 1013 | 995 | 980 | lbs |
| 32 | 502 | 481 | 460 | 451 | 445 | kg | |

Dimensions and clearances

Entire front of ice machine must be clear of obstructions/connections to allow removal.

1" (26 mm) clearance above ice machine for service.

1" (26 mm) minimum clearance on sides.

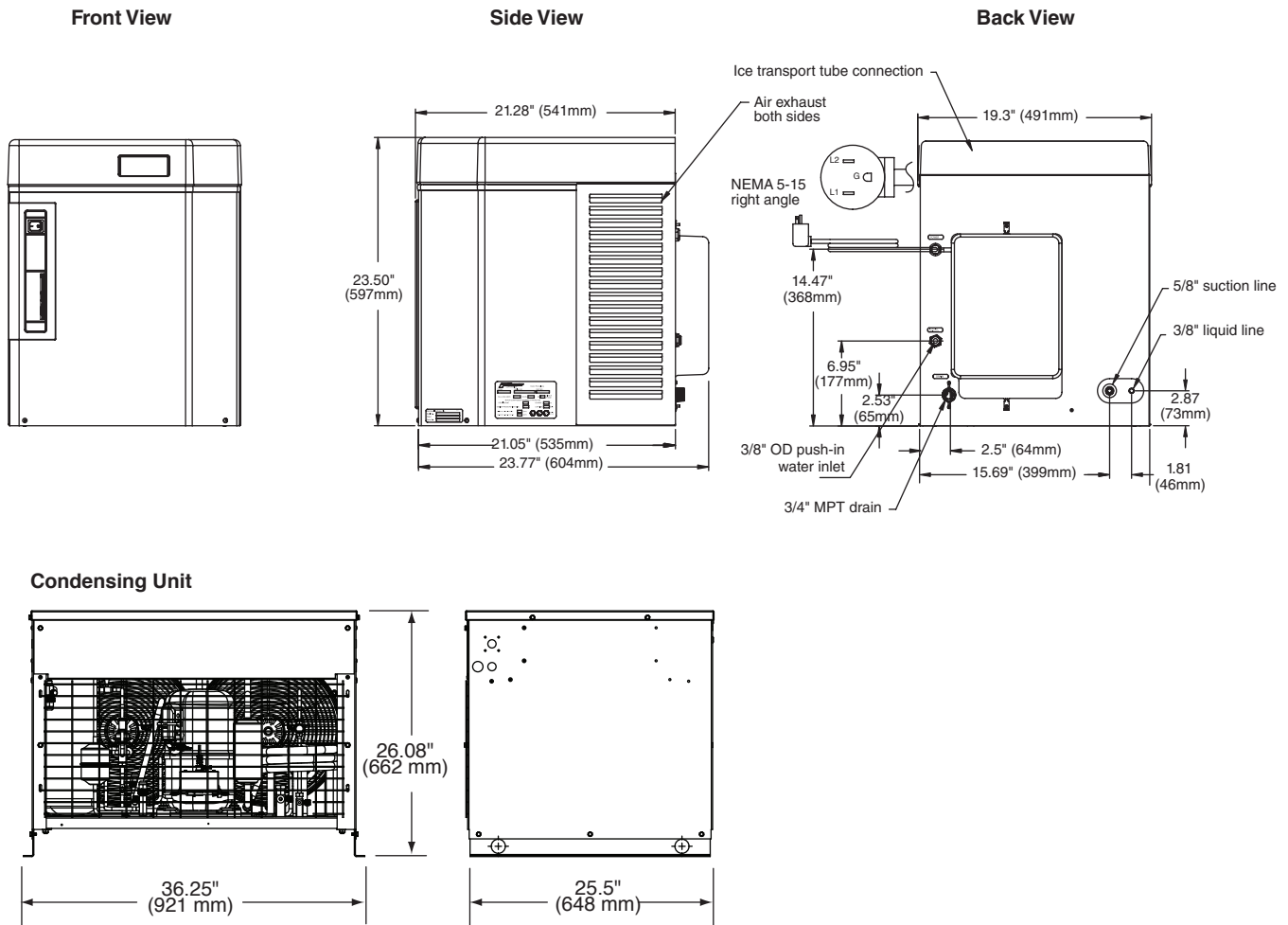

Operation

Cleaning and preventive maintenance (all models)

Note: Do not use bleach to sanitize or clean the ice machine.

Preventive maintenance

Periodic cleaning of Follett's ice machine system is required to ensure peak performance and delivery of clean, sanitary ice. The recommended cleaning procedures that follow should be performed at least as frequently as recommended, and more often if environmental conditions dictate.

Cleaning of the ice machine system, in most cases, should be performed by your facility's maintenance staff or a Follett authorized service agent. Regardless of who performs the cleaning, it is the operator's responsibility to see that this cleaning is performed according to the schedule below. Service problems resulting from lack of preventive maintenance will not be covered under the Follett warranty.

Weekly exterior care

The exterior may be cleaned with a stainless cleaner such as 3M Stainless Steel Cleaner & Polish or equivalent.

Semi-annual evaporator cleaning (every 6 months)

WARNING

- Wear rubber gloves and safety goggles (and/or face shield) when handling ice machine cleaner or sanitizer.

CAUTION

- Use only Follett approved SafeCLEAN™ Cleaner (part #00132001) and NU-CALGON IMS-II or IMS-III SANITIZER.
- Do not mix Cleaner and Sanitizer solutions together.
- DO NOT USE BLEACH.
- It is a violation of Federal law to use these solutions in a manner inconsistent with their labeling.
- Read and understand all labels printed on packaging before use.

Note: Complete procedure for cleaning and sanitizing MUST be followed. Ice must be collected for 10 minutes before putting ice machine back into service.

1. To clean – Remove cover. Press the CLEAN button. The machine will drain. Wait for the LO WATER light to come on (Fig. 1).

Note: For Ice Manager diverter valve application, refer to manual 00175273 for ice machine and diverter valve cleaning process.

Fig. 1

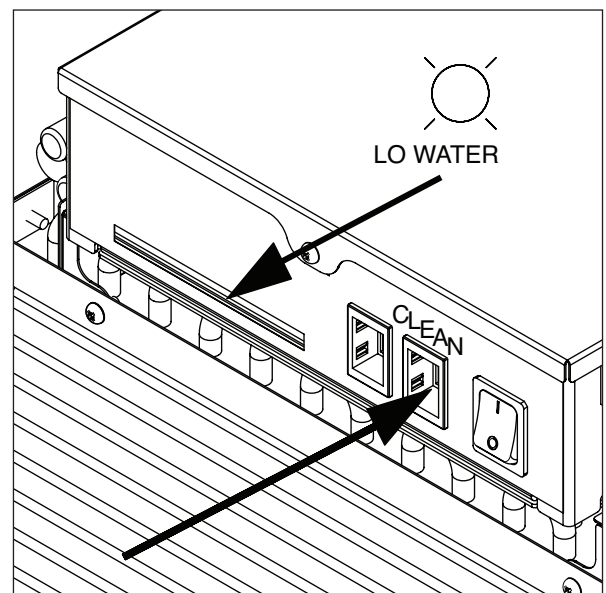

- Mix 1 gallon (3.8 L) 120 F (49 C) water and 7 oz (198 g) (one 7 ounce packet of Follett SafeCLEAN ice machine cleaner, P/N 00132001). Locate cleaning cup. Fill until HI WATER light comes on (Fig. 2).

Note: Do not use bleach to sanitize or clean the ice machine.

Fig. 2

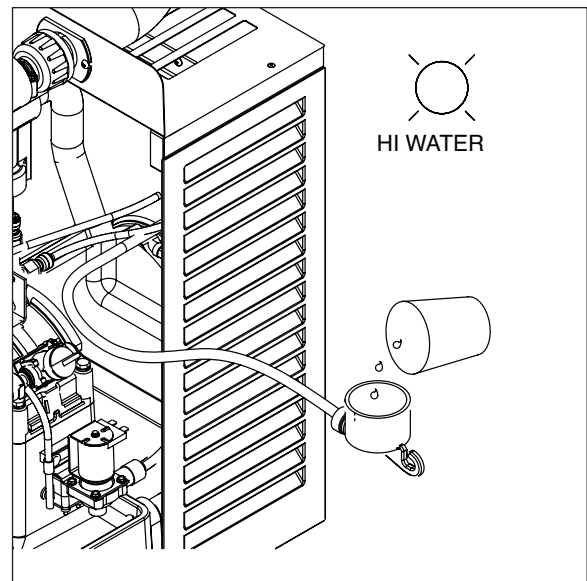

- Replace cover on cleaning cup. Wait until machine restarts. Machine will clean, then flush 3 times in approximately 12 minutes (Fig. 3).

Fig. 3

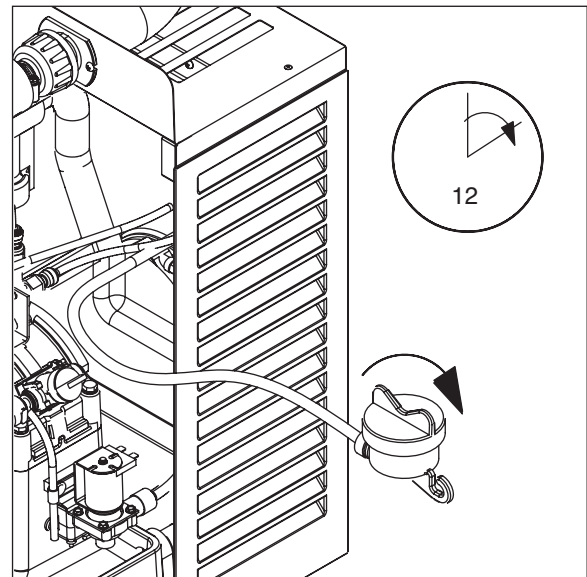

- To sanitize – Press CLEAN button. The machine will drain. Wait for LO WATER light to come on (Fig. 4).

Fig. 4

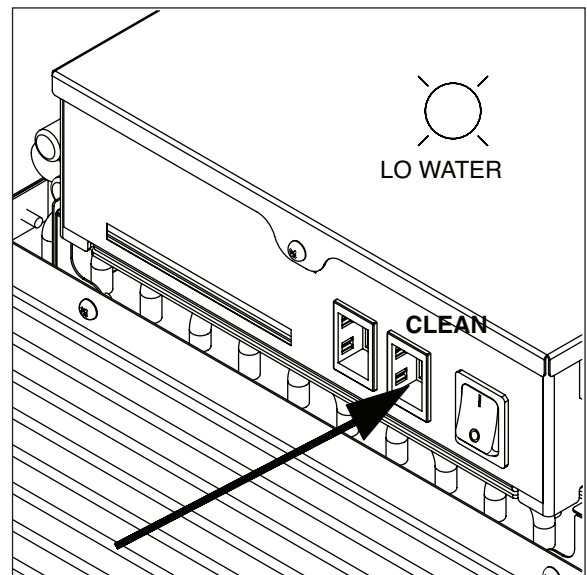

- Mix 1 gallon 120 F (49 C) water and 1.6 oz (48 ml) NU-CALGON IMS-II or IMS-III SANITIZER. Fill until HI WATER light comes on (Fig. 5).

Note: Do not use bleach to sanitize or clean the ice machine.

Fig. 5

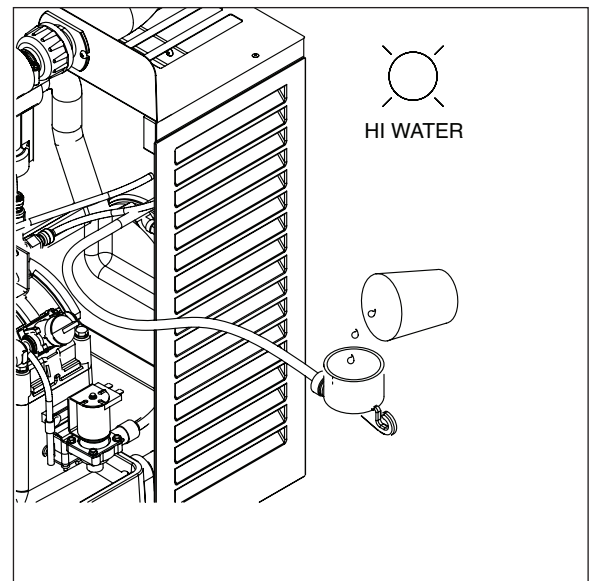

- Replace cover on cleaning cup. Wait until machine restarts. Machine will sanitize, then flush 3 times in approximately 12 minutes (Fig. 6).

Fig. 6

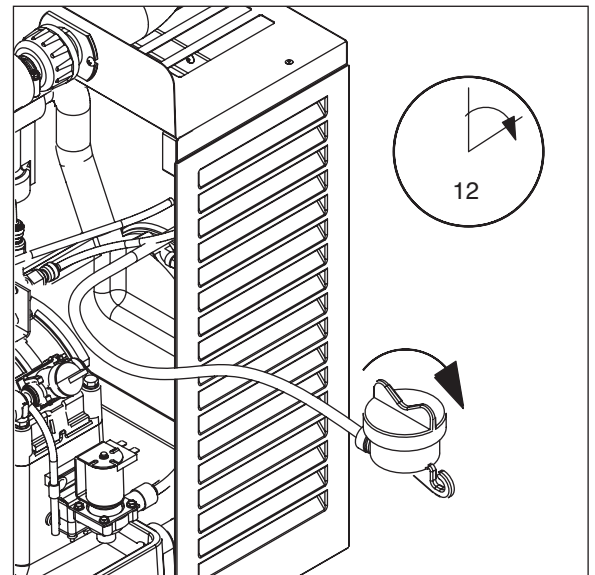

- To clean transport tube – Press power switch OFF (Fig. 7).

Fig. 7

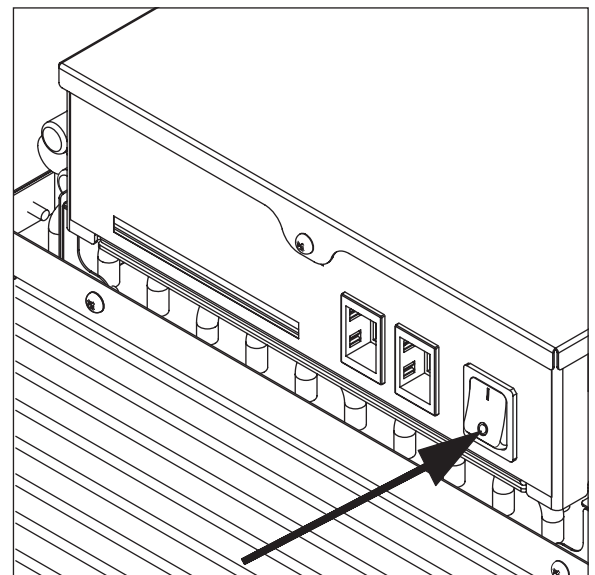

8. Disconnect coupling as shown (Fig. 8).

Fig. 8

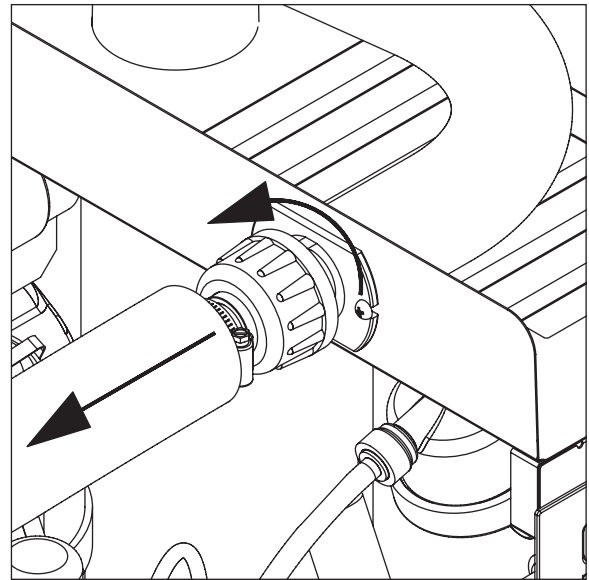

9. Using disposable food service grade gloves, insert dry Sani-Sponge™ (kit P/N 00132068). Next, insert Sani-Sponge soaked in Nu-Calgon IMS-II or IMS-III sanitizer solution. Push both Sani-Sponges down ice transport tube with supplied pusher tube (Fig. 9).

Fig. 9

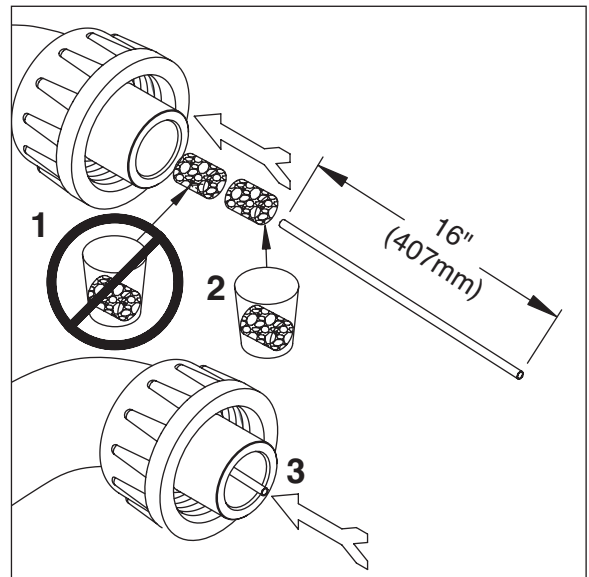

10. Remove and discard 16" (407 mm) pusher tube (Fig. 10).

Fig. 10

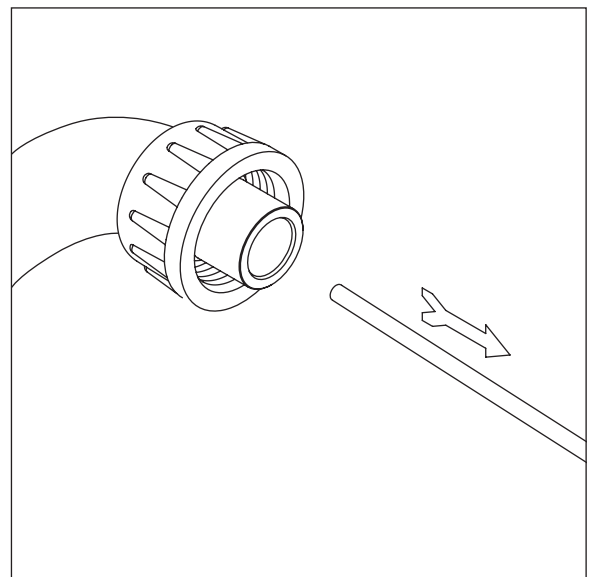

11. Reconnect coupling. Press power switch ON. Ice pushes Sani-Sponges through tube (Fig. 11).

Fig. 11

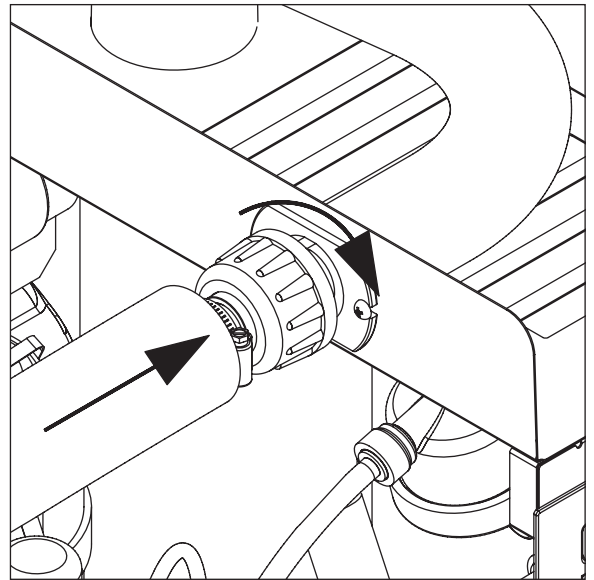

12. Place a sanitary (2 gallon or larger) container in bin or dispenser to collect Sani-Sponges and ice for 10 minutes. Collect 5.5 lb (3 kg) of ice from unit. Discard ice and Sani-Sponges (Fig. 12).

Fig. 12

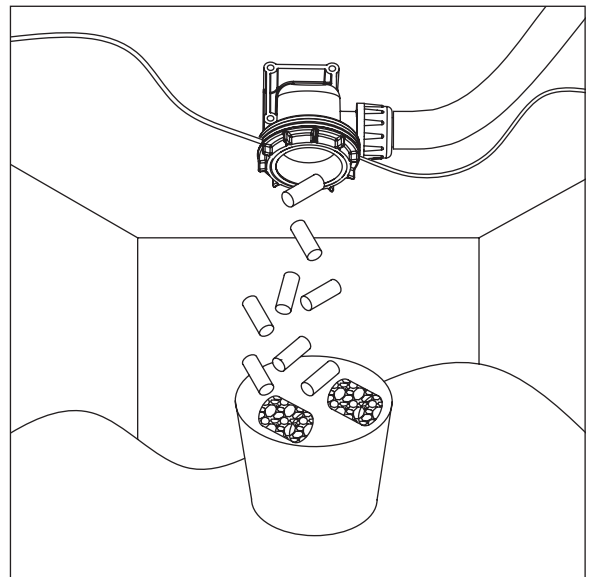

Service

Ice machine operation (all models)

Follett's ice machine consists of five distinct functional systems covered in detail as follows:

- Water system
- Electrical control system
- Mechanical assembly
- Refrigeration system
- Bin full

The Horizon ice machine overview

The Follett Horizon ice machine uses a horizontal, cylindrical evaporator to freeze water on its inner surface. The refrigeration cycle is continuous; there is no batch cycle. The evaporator is flooded with water and the level is controlled by sensors in a reservoir. A rotating auger (22 RPM) continuously scrapes ice from the inner wall of the evaporator. The auger moves harvested ice through the evaporator into an ice extrusion canal. The ice is forced through a restrictive nozzle that squeezes out the water and creates the Chewblet. The continuous extrusion process pushes the Chewblets through a transport tube into a dispenser or bin.

A solid state PC board controls and monitors the functionality of the ice machine. In addition to sequencing electrical components, the board monitors various operational parameters. A full complement of indicator lights allows visual status of the machine's operation. Additionally, the PC board controls the self-flushing feature of the ice machine. The evaporator water is periodically drained and replenished to remove minerals and sediment.

A unique "bin full" detection system is incorporated in the Horizon ice machine. A switch located at the ice discharge port of the machine detects the position of the transport tube. When the bin fills up with ice, the transport tube moves out of the normal running position, and the switch turns the ice maker off. A domed housing at the end of the transport tube contains the ice extrusion loads during shut down.

Harvest system diagram

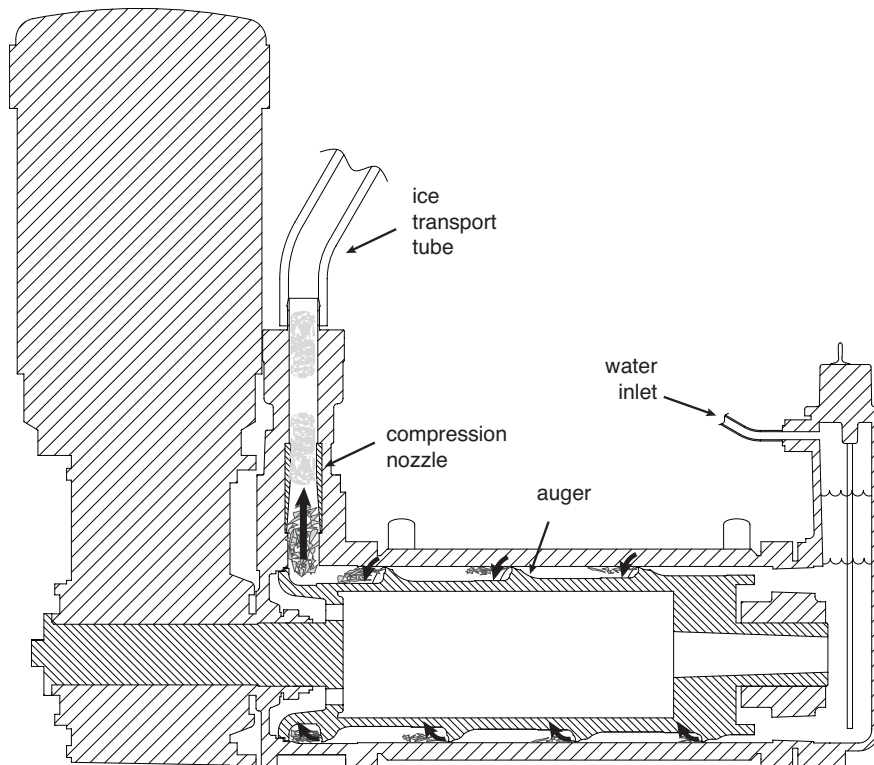

Water system

The water level in the evaporator is controlled by a feed solenoid and level detecting sensors. Referencing the diagram below, water sensing rods extend down into the reservoir at the end of the evaporator assembly. The system works via electrical conductivity as follows:

One of the longest probes is a common. When water is between any of the other probes and the common, the PC board will sense the activation. During normal operation, the water level rises and falls between the Normal High and Normal Low sensors. As water is consumed to make ice, the level will fall until the Normal Low sensor is exposed, triggering the water feed solenoid on. Water will fill until the Normal High sensor is activated.

Additional sensors are incorporated in the reservoir for alarm and cleaning/flushing conditions.

Note: The potable water dissolved solids content must be greater than 10 ppm for the water control system to function properly. If using reverse osmosis water filtration system, ensure T.D.S level is greater than 10 ppm.

Water system diagram

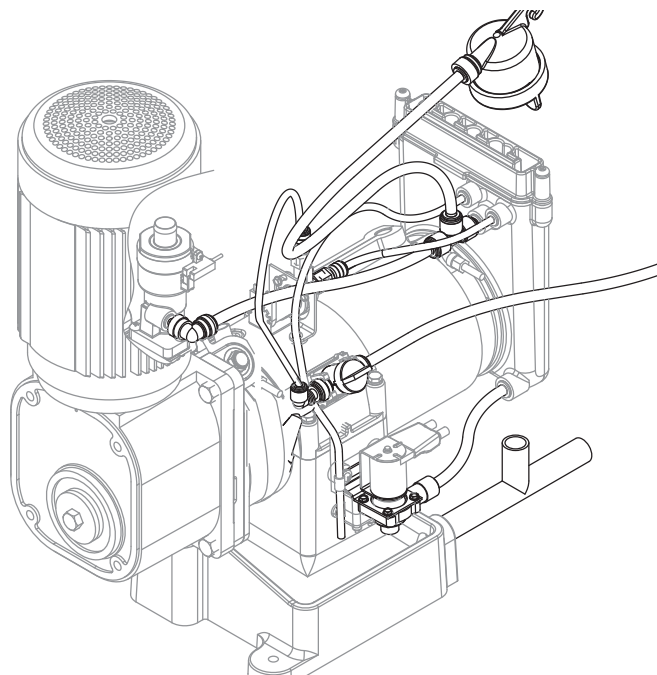

Water level diagram

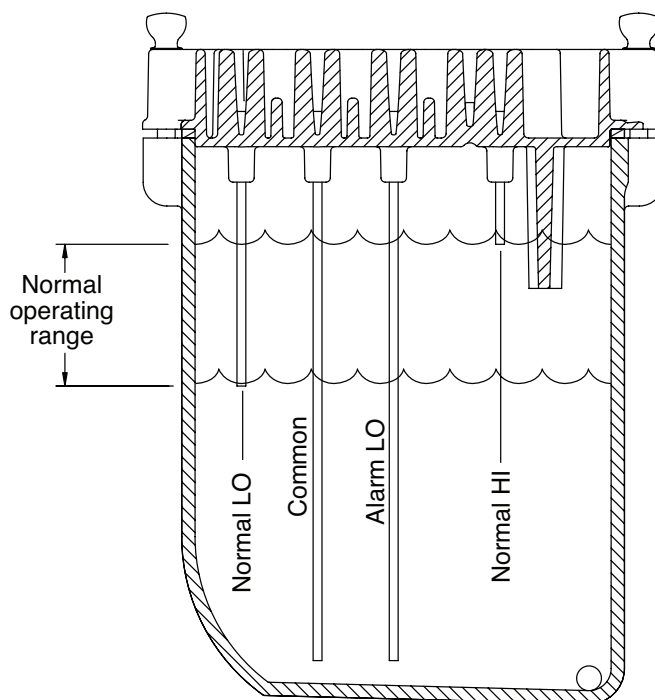

Electrical system

Normal control board operation

The PC board indicator lights provide all the information necessary to determine the machine's status. Green indicator lights generally represent "go" or normal operation; Yellow indicators represent normal off conditions; Red indicators generally represent alarm conditions, some of which will lock the machine off.

A green light labeled POWER indicates power to the machine. A flashing green light labeled CPU is normal and indicates that the Central Processing Unit "heart beat" is working. All other normal operation status indicators are covered as follows:

| Ice machine disposition | Operating conditions |
|--|----------------------|
| Legend: ● ON ○ OFF ◐ ON or OFF ✕ FLASHING | |

1. Ice machine is making ice.

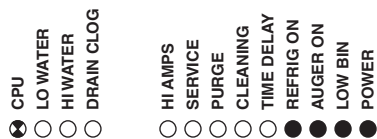

1. **Normal running.**

2. Ice machine is not making ice.



2. **Normal time delay.** When the bin fills with ice, the LOW BIN light goes out and the refrigeration and auger drive systems immediately shut down. The TIME DELAY light comes on, initiating the time delay period. When the time delay expires, the machine will restart provided that the LOW BIN light is on.

3. Ice machine is not making ice.



3. **Normal purge indicator.** After a selected period of ice making time has elapsed (1 or 2 hours), the ice machine will automatically self-flush. The refrigeration system will shut down but the gear motor will continue to run. After the flush is complete the machine will refill and start without a time delay.

Test points:

The Horizon PC board incorporates on-board test points that can be used to determine various electrical outputs. The test point holes allow a standard probe to be inserted for quick voltage measurement.

Error faults:

The Horizon PC board monitors various operating parameters including high pressure, auger gearmotor amperage limits, clogged drain, and high and low water alarm conditions. There are two types of errors namely “hard” or “soft”. A hard error is one that shuts the machine off and will not allow restart until the reset button is pressed. Even cycling power will not reset a hard error. A soft error can either be automatically reset should the condition rectify, or if power is cycled. Should an error occur, consult the troubleshooting guide in this manual or a Follett service technician.

Note: there are two types of LO WATER and HI AMPS errors as listed below.

Soft errors:

HI AMPS: The PC board monitors the amperage of the auger motor. Should the gear motor experience current draw above the 8.4 amps limit the machine will shut down and the TIME DELAY, HI AMP, and SERVICE LED's will be illuminated. After the time delay the machine will restart and the TIME DELAY, HI AMP, and SERVICE LED's will clear.

LO WATER: During operation, the water level cycles between the normal low and normal high sensors. Should the water be shut off to a running machine, a soft error will occur. The error sequence is as follows: During operation, the water level falls to the normal low sensor, and when it does the water feed solenoid is energized. If water is not detected at the normal low sensor within 120 seconds, a soft error will occur. The machine will shut down, but the water feed solenoid will remain energized. Should water return, it will fill to the normal low sensor and the machine will resume normal operation. The error will clear automatically.

DRAIN CLOG: The drain clog sensor, located in the plastic drain pan behind the drain solenoid, will detect the presence of water just below the top edge of the pan. If water does not properly flow out of the drain pan it will rise to the sensor, especially during a self-flushing purge cycle. Turning the power switch off and then back on again will restart the ice machine.

Hard error:

HI AMPS:

1. “Two strikes” feature. If the gearmotor has a second HI AMP occurrence during the countdown period (6 hours after a HI AMP time delay) a hard error will occur and the HI AMP and SERVICE LED's will be illuminated. Reset button must be pressed to clear this error.
2. No current. To prevent the refrigeration system from running without gearmotor rotation the PC board will indicate HIGH AMP and SERVICE if the drive relay is energized and there is no current draw. Reset button must be pressed to clear this error.

HI PRESSURE: Should the refrigeration pressure rise above 450 psi, the remote condenser's high-pressure switch will shut down the compressor. When the pressure falls back below the reset point of 280 psi, the compressor will restart.

LO WATER:

1. There is a sensor in the water reservoir that reaches down to the very bottom. The machine will not start if water is not present at this sensor.
2. A hard error will occur should water not be present within 60 seconds of power up or if the sensors are disconnected or damaged. Reset button must be pressed to clear this error.

Relay output indication:

Each relay on the board has an indicator light associated with its output. For example, when the relay for the water feed solenoid is energized, the adjacent indicator light glows green.

Comp/Sol output:

The output for the liquid line solenoid is labeled COMP/SOL.

Single-phase condensing unit wiring diagram

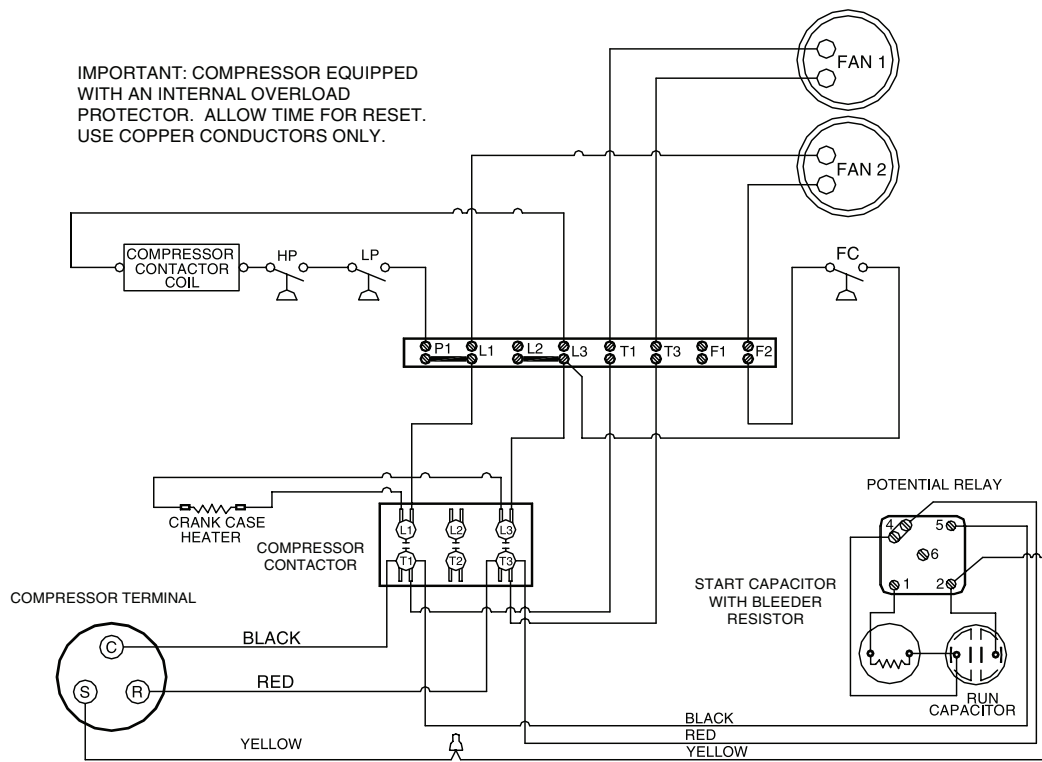

3-phase condensing unit wiring diagram

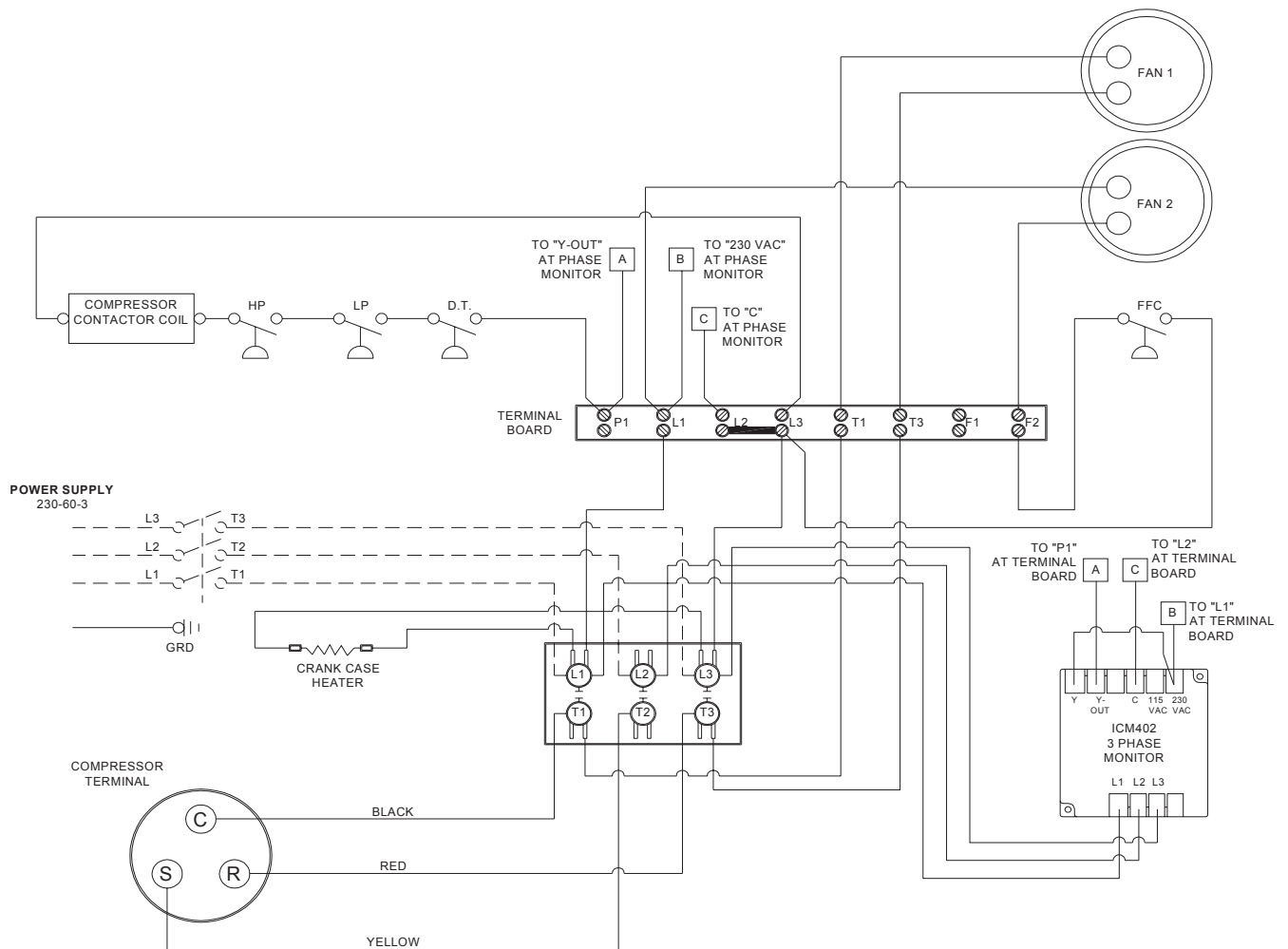

Mechanical system

Evaporator disassembly

1. Press PURGE button to purge evaporator, and then turn power OFF.
2. Unscrew and remove stream divider as shown.

Fig. 13

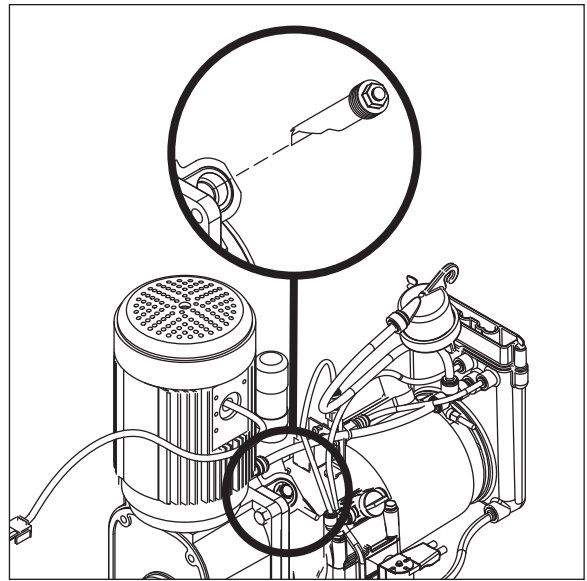

3. Unplug and remove gearmotor as shown.
4. Remove all traces of petrol-gel from the auger shaft.

Fig. 14

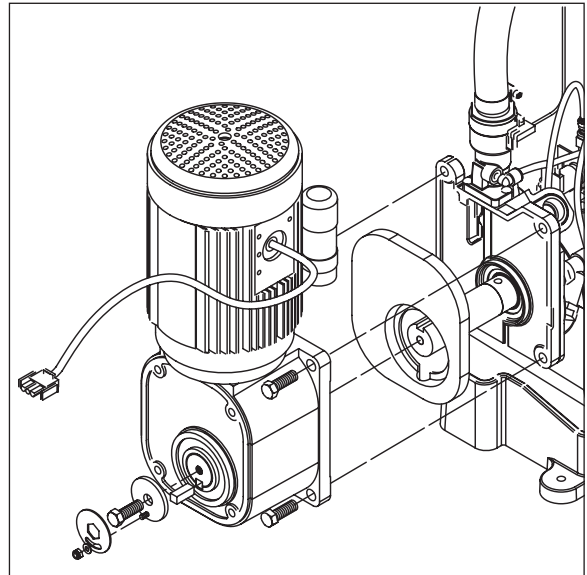

5. Unscrew and disconnect transport tube from louvered docking assembly.
6. Unplug sensor at the electrical box.
7. Remove vent tube from shuttle housing as shown.

Fig. 15

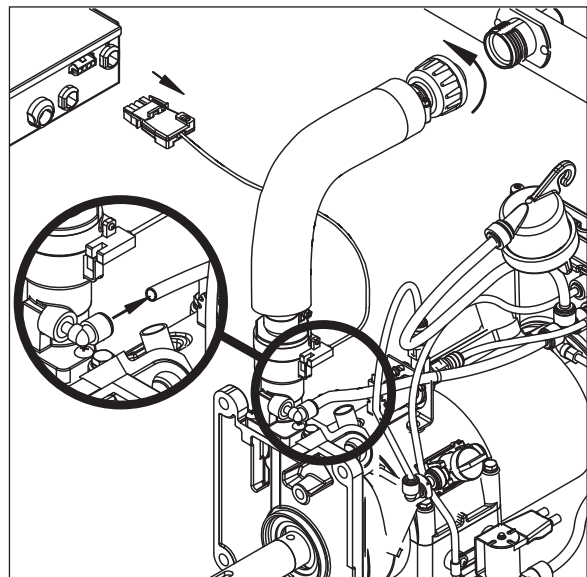

8. Unscrew and disconnect transport tube from louvered docking assembly.
9. Unplug sensor at the electrical box.
10. Remove vent tube from shuttle housing as shown.

Fig. 16

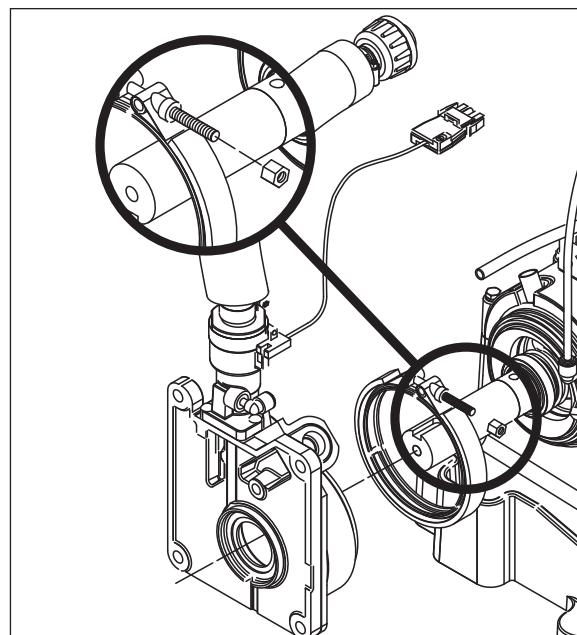

11. Remove and discard mating ring and seal.
12. Carefully remove auger.

Fig. 17

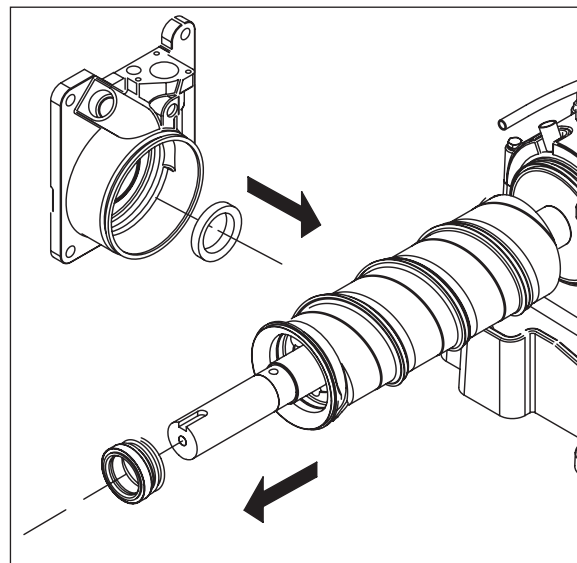
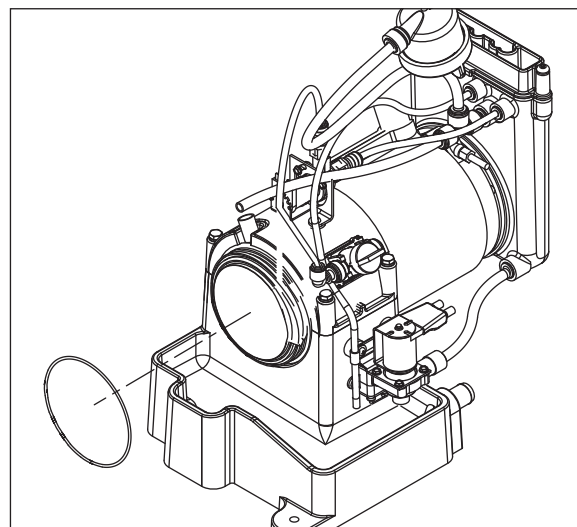

Fig. 18



Evaporator reassembly

1. Remove and inspect O ring seal. Discard if damaged in any way.
2. Clean O ring groove. Lubricate O ring with petrol-gel and reinstall.

3. Press new mating ring into main housing as shown.
4. Lube the shaft with liquid soap in the area shown and slip on seal and spring.

Note: Do not touch the sealing surfaces. Use cardboard disk to install.

Fig. 19

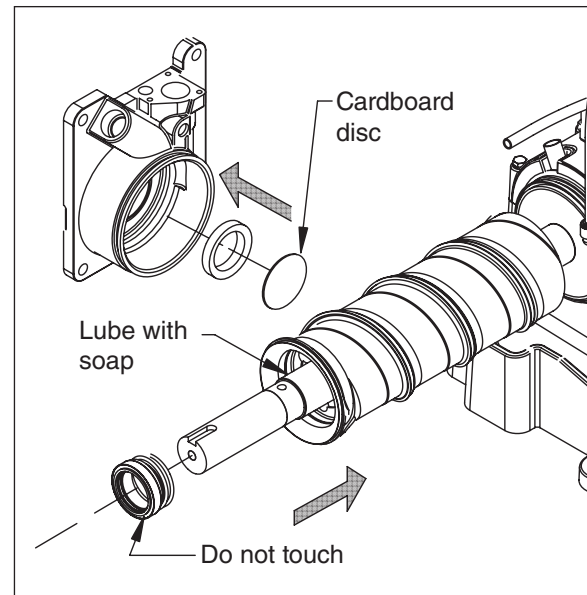

5. Reinstall main housing as shown.

Fig. 20

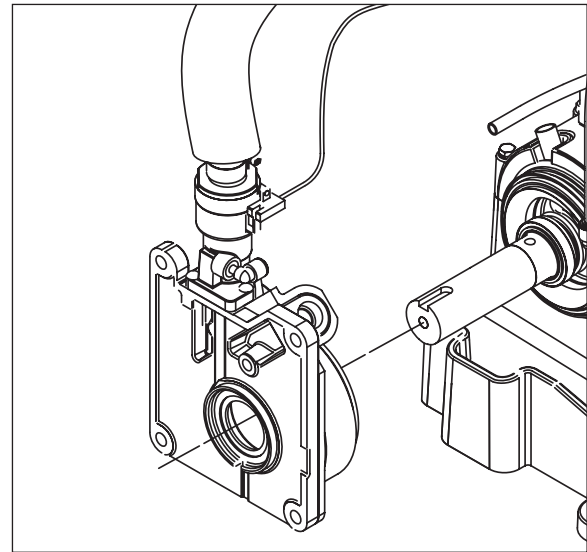

6. Orient auger shaft with keyway in the upward position.
7. Force main housing into position against evaporator and place 1/4" (7 mm) diameter Phillips screwdriver into hole in the auger shaft.
8. Replace V-band clamp as shown.
9. Replace nut on V-band clamp and tighten.
10. Remove screwdriver.

Fig. 21

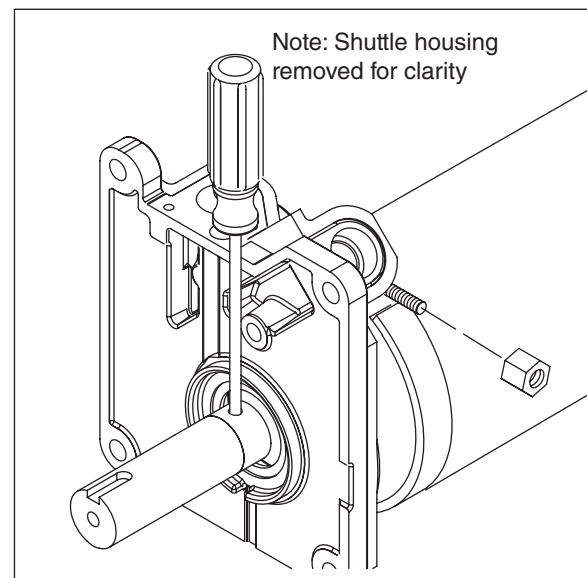

- 11. Reconnect transport tube to louvered docking assembly.
- 12. Plug sensor in at the electrical box.
- 13. Reconnect vent tube to the shuttle housing as shown.

Fig. 22

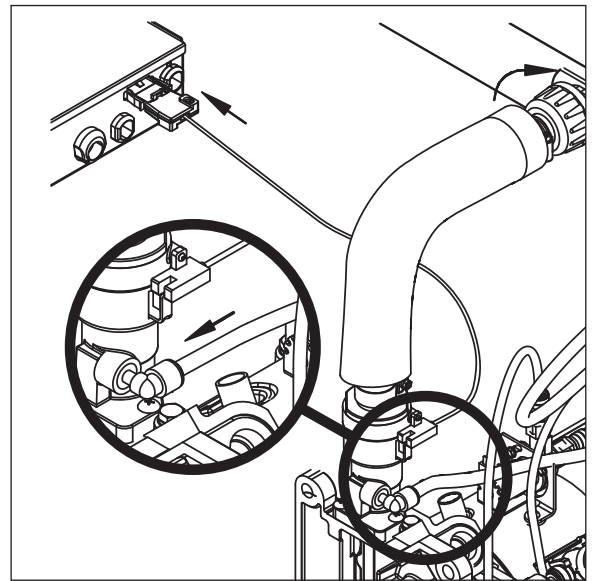

- 14. Apply a coat of petrol-gel to the auger shaft.
- 15. Install gearmotor, making sure that insulation is properly seated between gearmotor and main housing as shown.
- 16. Firmly tighten four gearmotor bolts in place.

Fig. 23

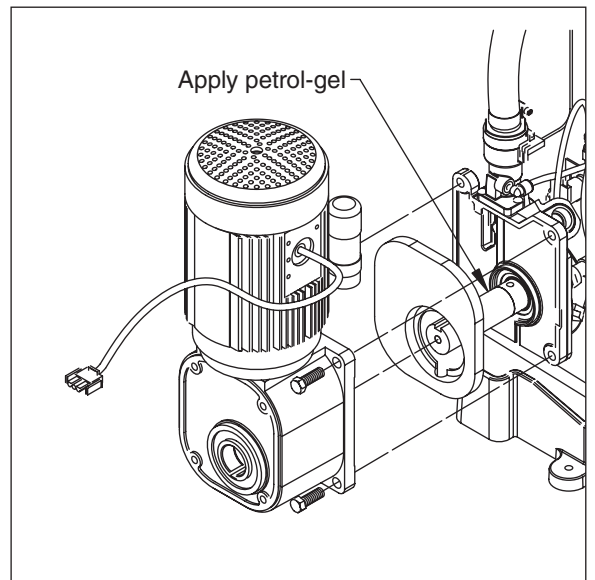

- 14. Insert a bolt into the auger shaft and finger tighten.
- 15. Using a wrench, rotate the shaft clockwise to align the keyways in the gear housing and the shaft so as to accept the key.
- 16. Insert the key into the keyway.

Fig. 24

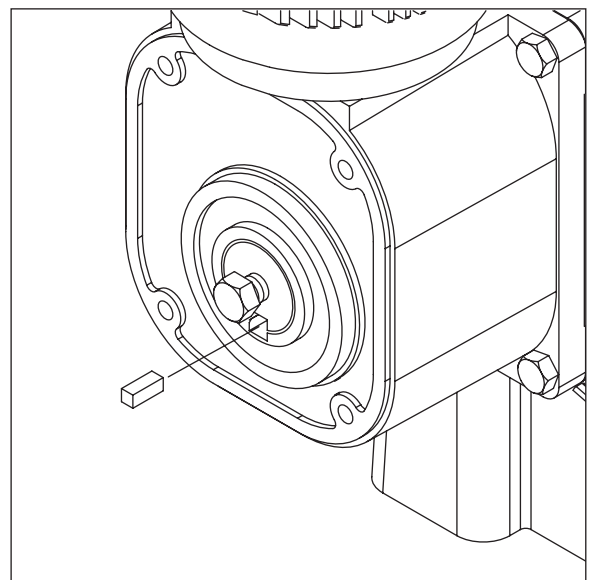

17. Remove bolt and reinstall the washer and bolt. Place retainer over bolt and secure with nut and washer.

Fig. 25

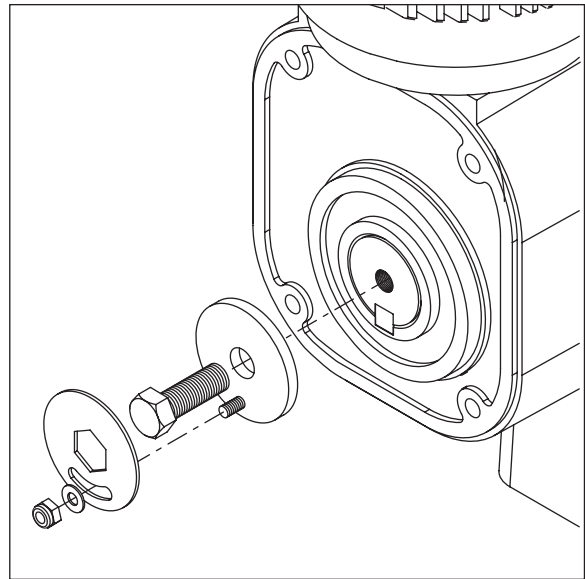

18. Lubricate body of stream divider with petrol-gel and reinstall.
19. Plug gearmotor power cord into electrical box

Fig. 26

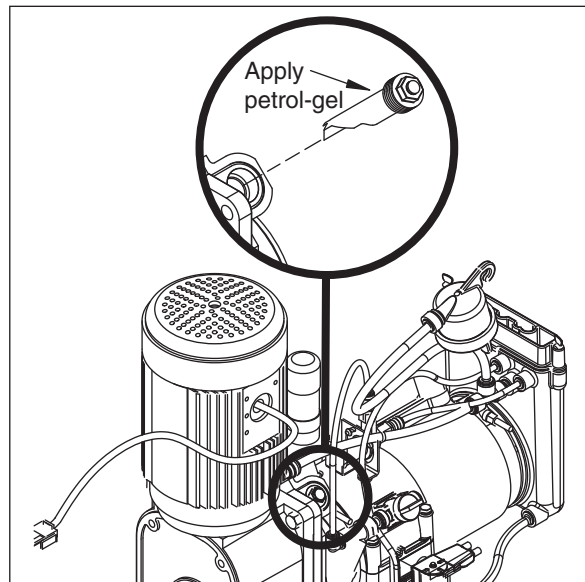

Refrigeration system

Condenser unit operation

The condensing unit is weatherproof and equipped to operate in ambient temperatures from -20 F to 120 F (-29 C to 48.9 C). The condensing unit is controlled by a low pressure control, which works in concert with a refrigerant solenoid valve on the evaporator module. On start-up, the refrigerant solenoid valve opens and suction pressure rises above the “on” set point of the control. The compressor and fan turn on and the refrigeration system operates. Upon shut down, the refrigerant solenoid closes. The compressor will pump down the ice machine evaporator and suction line until the low “off” set point is reached, at which point the compressor and fan will turn off.

Low ambient operation: Reliable operation at low outdoor ambient temperature is achieved with a pumpdown cycle, a crankcase heater and a head pressure control valve. When the outdoor ambient falls, the condensing pressure falls. This causes the discharge pressure to fall as well. When the discharge pressure falls below the dome pressure, the valve modulates open to the discharge port which allows discharge gas to bypass the condenser. Mixing the discharge gas with the liquid creates a high pressure at the condenser outlet, reducing the flow and causing liquid to back up in the condenser. Flooding the condenser reduces the area available for condensing. This reduction in effective condenser surface area results in a rise in condensing pressure. During summer conditions, the discharge pressure is high, thus closing the discharge port of the valve. Hence, there is full liquid flow from the condenser to the receiver.

A check valve is installed in the liquid line between the receiver and the condenser to prevent liquid migration from the receiver to the condenser during the off cycle. The low pressure control will start the condensing unit anytime the low side pressure rises above the set point and pump the refrigerant out until the pressure falls to the set point. The crankcase heater, which is energized whenever the condensing unit has power, keeps the compressor oil warmer than the coldest location in the system. This minimizes off cycle refrigerant migration. If power to the condensing unit is interrupted after the system is charged, the compressor should not be started unless the crankcase heater has been energized for at least 24 hours immediately prior to compressor startup. However the compressor can safely be started during the refrigeration system charging process (without the warm-up period) once sufficient refrigerant is in the system to maintain a positive pressure on the suction side of the compressor.

Under normal ambient operating conditions the left side condenser fan motor, when viewing the outdoor condensing unit from the compressor side, is not energized; therefore, the fan will pinwheel. During hot summer days, at elevated temperatures, the left side condenser fan will be energized to maintain the BTU efficiency of the condensing unit.

For additional information, please reference Horizon ice machine installation instructions for remote condensing units.

Refrigerant pressure data

| Air-cooled condensers (air) | 60 F/16 C | 70 F/21 C | 80 F/27 C | 90 F/32 C | 100 F/38 C |
|--------------------------------------|-----------|-----------|-----------|-----------|------------|
| Pressure (psig) discharge/suction | 229/32 | 232/32 | 244/33 | 252/35 | 253/36 |

Refrigerant charges

| R404A ice machine charge specifications | | |
|---|-----------------------------|-----------------|
| Model | Line Run | Charge |
| 1400 | 0 – 50 ft (0 – 15.2 m) | 11 lb (4.9 kg) |
| | 50 – 75 ft (15.2 – 22.9 m) | 12 lb (5.4 kg) |
| | 75 – 100 ft (22.9 – 30.5 m) | 13 lb (5.9 kg) |
| | 100 ft+ (30.5 m+) | Consult factory |

Refrigeration system diagram

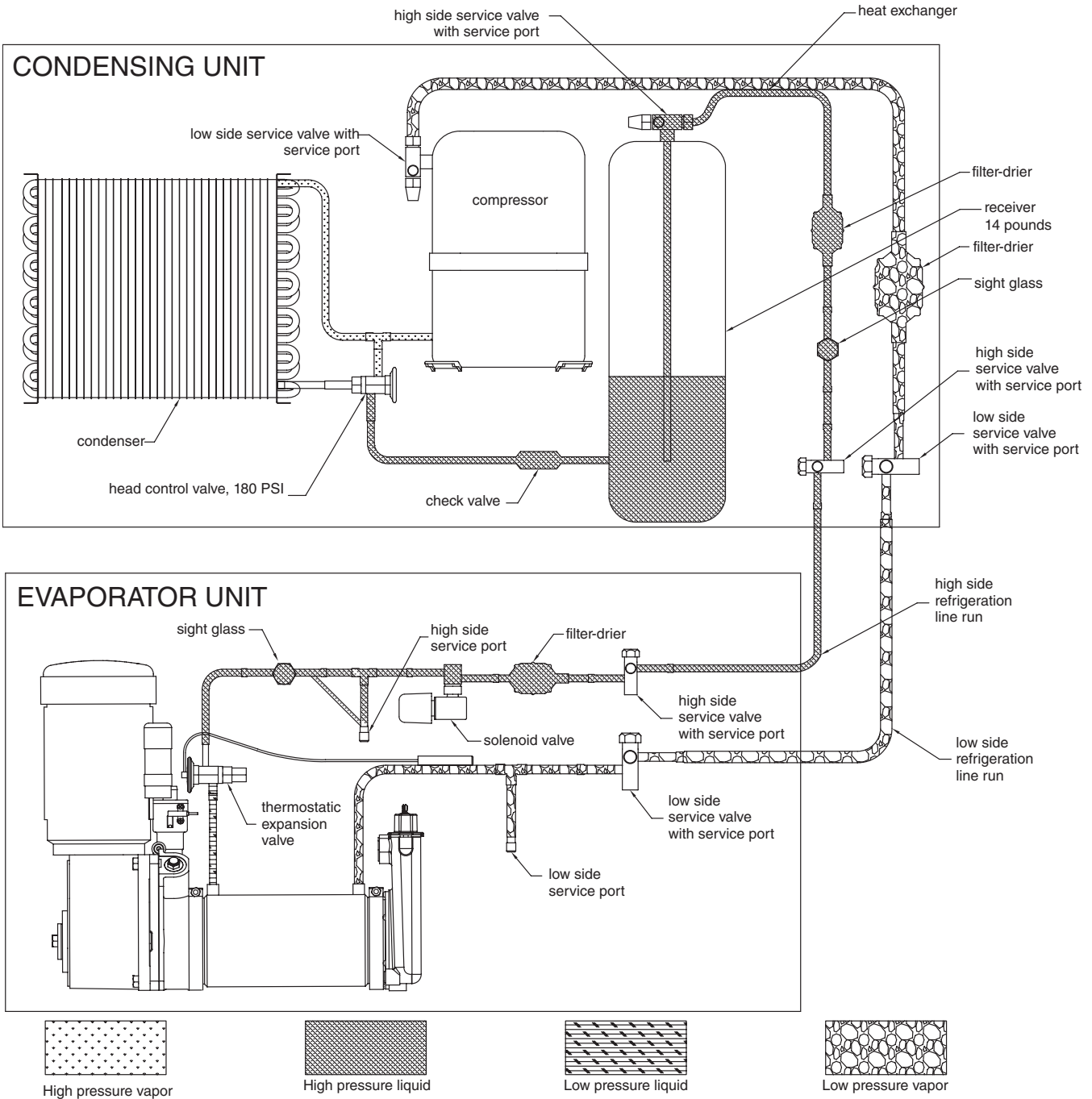

Refrigerant replacement requirements

1. Non-contaminated refrigerant removed from any Follett refrigeration system can be recycled and returned to the same system after completing repairs. Recycled refrigerant must be stored in a clean, approved storage container. If additional refrigerant is required, virgin or reclaimed refrigerant that meets ARI standard 700-88 must be used.
2. In the event of system contamination (for example, a compressor burn out, refrigerant leak, presence of non-condensibles or moisture), the system must be repaired, evacuated and recharged using virgin or reclaimed refrigerant that meets ARI standard 700-88.
3. Follett Corporation does not approve of recovered refrigerants. Improper refrigeration servicing procedures will void the factory warranty.

Evacuation

Evacuate the system to a level of 500 microns. When the 500 micron level is reached, close valves and both manifold and shut down the vacuum pump. Allow the system to sit for approximately 20 minutes. During this period the system pressure should not rise. If the system pressure rises and stabilizes there is moisture in the system and further evacuation is needed. If the pressure continues to rise check the system for leaks.

Ambients (evaporator unit)

Air temperature¹

Minimum

50 F/10 C

Maximum

100 F/37.8 C

Water temperature²

45 F/7 C

90 F/32.2 C

¹Ambient air temperature is measured at the air-cooled condenser coil inlet.

²Ambient water temperature is measured in the ice machine float reservoir.

Ice capacity test

Ice machine production capacity can only be determined by weighing ice produced in a specific time period.

1. Replace all panels on ice machine.
2. Run ice machine for at least 15 minutes.
3. Weigh and record weight of container used to catch ice.
4. Catch ice for 15 or 20 minutes.
5. Weigh harvested ice and record total weight.
6. Subtract weight of container from total weight.
7. Convert fractions of pounds to decimal equivalents (ex. 6 lb 8 oz = 6.5 lb).
8. Calculate production using following formula:

$$\frac{1440 \text{ min.} \times \text{wt. of ice produced}}{\text{Total test time in minutes}} = \text{Production capacity/24 hr.}$$

9. Calculated amount per 24 hours should be checked against rated capacity for same ambient and water temperatures in Ice Production Tables.

“Bin full” detection system

The Follett Horizon ice machine incorporates a unique “bin full” detection system, that consists of the shuttle and actuator. The shuttle incorporates a flag and sensor. Referencing the figure below, the normal running position of the flag is down, out of the sensor. When the bin fills to the top and ice can no longer move through the tube, the machine will force the shuttle flag up into the sensor, shutting the machine off. The shuttle actuator, located above the ice bin allows the ice to curl up within it when the bin is full to contain any forces. In this way, there are no loads generated that would tend to lift off the lid of the bin.

Shuttle flag and sensor

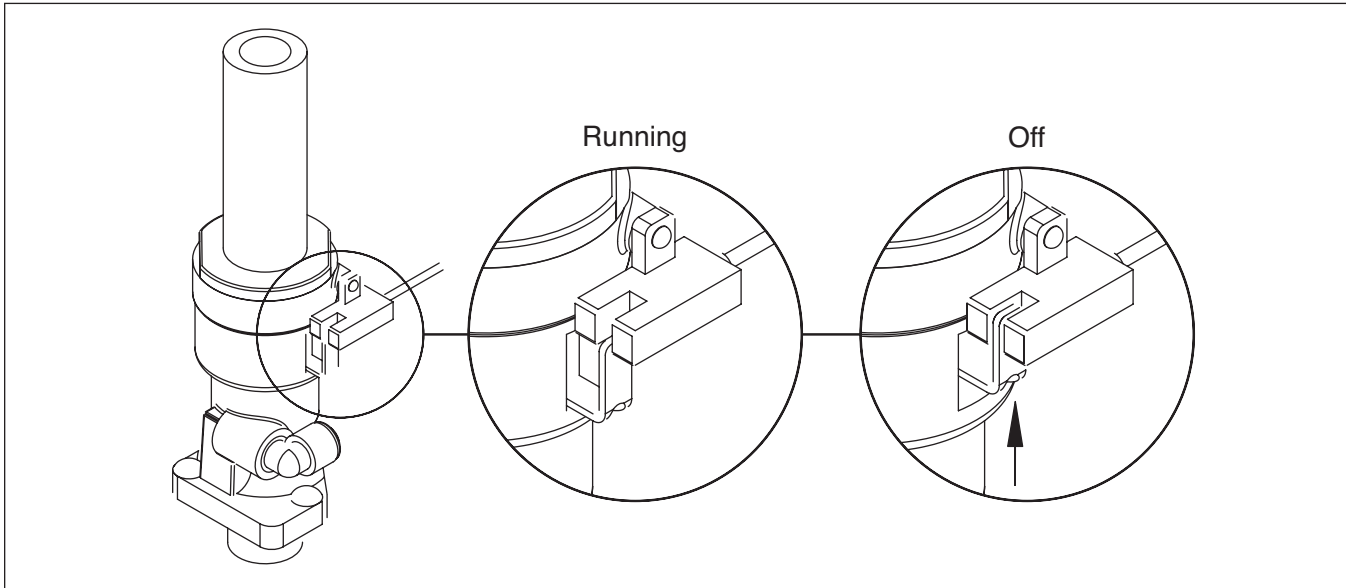

Shuttle actuator

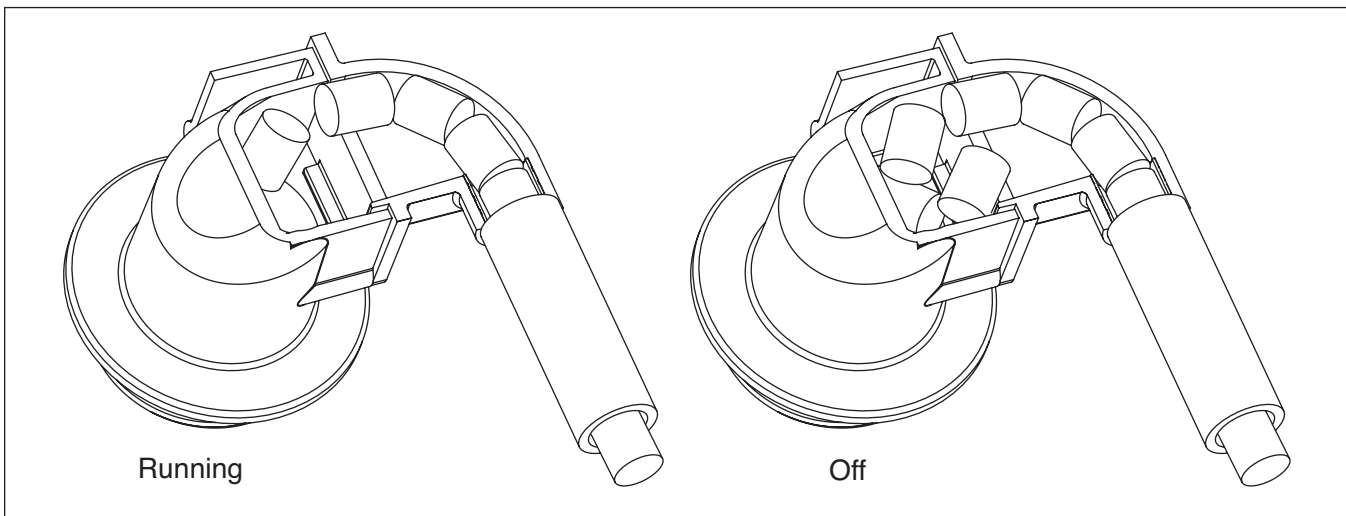

Troubleshooting

Please see "Service" section for a description of each function.

| Ice machine disposition | Possible causes | Corrective action |
|---|--|--|
| Legend: ● ON ○ OFF ◐ ON or OFF ⚡ FLASHING | | |
| 1. Ice machine is in running condition but not making ice. CPU LO WATER HI WATER DRAIN CLOG ⚡ ○ ○ ○ HI PRESS HI AMPS SERVICE PURGE CLEANING TIME DELAY REFRIG ON AUGER ON LOW BIN POWER ○ ○ ○ ○ ○ ○ ● ● ● ● | 1. Defective compressor. 2. Defective start relay. 3. Defective start capacitor. 4. Defective run capacitor. 5. Defective main contactor. 6. No output from PC board. 7. Machine in Purge cycle. | 1. Replace compressor. 2. Replace start relay. 3. Replace start capacitor. 4. Replace run capacitor. 5. Replace main contactor. 6. Replace PC board. 7. Check for Purge operation. |
| 2. Machine in TIME DELAY without full bin. CPU LO WATER HI WATER DRAIN CLOG ⚡ ○ ○ ○ HI PRESS HI AMPS SERVICE PURGE CLEANING TIME DELAY REFRIG ON AUGER ON LOW BIN POWER ○ ○ ○ ○ ○ ◐ ○ ○ ○ ● | 1. Ice jamming due to improperly installed transport tube causing a false shuttle. 2. Shuttle stuck in up position. 3. Damaged or improperly installed thermostat (open). 4. Transport tube backed-out of coupling. | 1. Correct transport tube routing. 2. Repair or replace shuttle mechanism. 3. Replace or reposition thermostat. 4. Correct coupling installation. |
| 3. Ice machine is not making ice. HI AMPS. CLEANER FULL DRAIN CLOG ○ ○ HI PRESS HI AMPS SERVICE MAINT/CLEAN LOW WATER TIME DELAY NOT USED MAKING ICE LOW BIN POWER ON ○ ● ○ ○ ○ ○ ○ ○ ○ ○ ⚡ | 1. Poor water quality causing ice to jam auger. 2. Damaged shuttle mechanism or thermostat (closed). 3. Kinked transport tube (thermostat systems). 4. Intermittent drive output from PC board. Evaporator will freeze causing a hi amps error. 5. Gearmotor is unplugged. | 1. Clean ice machine. Increase flushing frequency. 2. Replace or repair shuttle mechanism/thermostat. 3. Straighten transport tube. 4. Replace PC board. 5. Plug in gearmotor. |
| 4. Ice machine is not making ice. Drain clog. CPU LO WATER HI WATER DRAIN CLOG ⚡ ○ ○ ● HI PRESS HI AMPS SERVICE PURGE CLEANING TIME DELAY REFRIG ON AUGER ON LOW BIN POWER ○ ○ ● ○ ○ ○ ○ ○ ○ ○ ○ ● | 1. Drain hose kinked or plugged causing water to back up. 2. Improper floor drain routing/pitch causing water to back up. 3. High TDS levels and leaking drain solenoid may cause an errant drain clog. | 1. Remove kink or blockage from drain hose. 2. Re-route floor drain. 3. Clean area around drain sensor and/or replace Drain solenoid valve. |

| Ice machine disposition | Possible causes | Corrective action |
|---|---|--|
| Legend: ● ON ○ OFF ◐ ON or OFF ✖ FLASHING | | |
| 5. Ice machine is not making ice. Locked in PURGE. CPU LO WATER HI WATER DRAIN CLOG ✖ ○ ○ ○ HI PRESS HI AMPS SERVICE PURGE CLEANING TIME DELAY REFRIG ON AUGER ON LOW BIN POWER ○ ○ ○ ● ○ ◐ ○ ○ ◐ ● | 1. A self-flush occurred but could not drain evaporator due to a failed drain solenoid valve. 2. A self-flush occurred but could not drain evaporator due to water reservoir or ice machine not being level. | 1. Replace drain solenoid valve. 2. Level ice machine. Check water reservoir to make sure it is not tilted towards the compressor. |
| 6. The CPU is not flashing. CPU LO WATER HI WATER DRAIN CLOG ◐ ○ ○ ○ HI PRESS HI AMPS SERVICE PURGE CLEANING TIME DELAY REFRIG ON AUGER ON LOW BIN POWER ○ ○ ○ ○ ○ ○ ◐ ◐ ◐ ● | 1. Processor has been damaged. | 1. Replace PC board. |
| 7. Ice machine is making ice. Excessive water in bin or coming into bin from transport tube. CPU LO WATER HI WATER DRAIN CLOG ✖ ○ ○ ○ HI PRESS HI AMPS SERVICE PURGE CLEANING TIME DELAY REFRIG ON AUGER ON LOW BIN POWER ○ ○ ○ ○ ○ ○ ● ● ● ● | 1. Failed water sensors. Processor assumes there is no water when there is water. 2. Blocked reservoir vent. 3. Defective water feed solenoid valve. Stuck in open position. | 1. Clean or replace water probe assembly. Check wiring connections. 2. Clean or replace vent tubes. 3. Replace water feed solenoid valve. |
| 8. Ice machine is not making ice. Lo water. CPU LO WATER HI WATER DRAIN CLOG ✖ ● ○ ○ HI PRESS HI AMPS SERVICE PURGE CLEANING TIME DELAY REFRIG ON AUGER ON LOW BIN POWER ○ ○ ● ○ ○ ○ ○ ○ ● ● | 1. Water supply is turned off. 2. Low water pressure. 3. Defective water feed solenoid valve. Stuck in closed position. 4. No water feed output from PC board. | 1. Turn water supply on. If evaporator was completely empty the reset button may have to be pressed to restart the ice machine. 2. Ice machine will eventually start when water reaches normal lo level. 3. Replace water feed solenoid valve. 4. Replace PC board. |

Replacement parts

Order parts online
www.follettice.com

Evaporator assembly

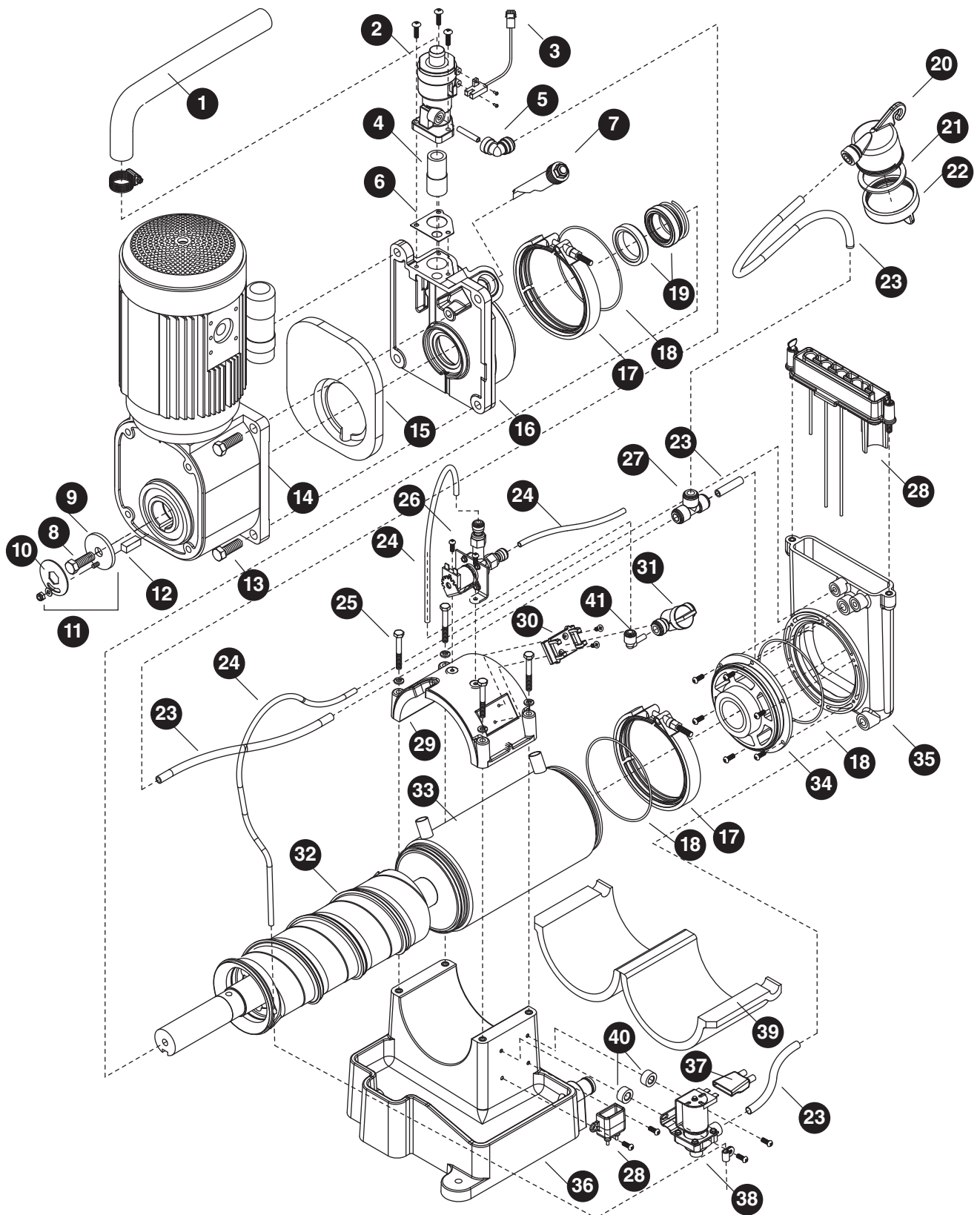

| Reference # | Description | Part # |
|-------------|--|----------|
| 1 | Tube, ice transport, molded | 00175299 |
| 2 | Shuttle assembly (includes gasket and nozzle) | 00130815 |
| 3 | Switch, optical | 00130849 |
| 4 | Compression nozzle | 00115774 |
| 5 | Elbow, water | 00134502 |
| 6 | Gasket, shuttle | 00115600 |
| 7 | Stream divider | 00142521 |
| 8 | Auger bolt | 00116988 |
| 9 | Washer | 00161513 |
| 10 | Retainer, auger bolt | 00161356 |
| 11 | Kit, auger bolt (auger bolt, washer, retainer, nut and washer) | 00161406 |
| 12 | Key | 00117804 |
| 13 | Bolts, gearmotor mounting (4) required | 00130641 |
| 14 | Gearmotor, 120 V (includes capacitor) | 00130799 |
| 15 | Gasket, gearmotor | 00121632 |
| 16 | Main housing (includes auger shaft seal and O ring) | 00142539 |
| 17 | Coupling, V-band | 00130708 |
| 18 | O ring | 00116962 |
| 19 | Seal, auger shaft | 00112946 |
| 20 | Cup, sanitizer | 00130674 |
| 21 | Gasket, sanitizer | 00124032 |
| 22 | Cap, sanitizer (includes gasket) | 00130880 |
| 23 | Tubing, water, 3/8" OD (per foot) | 502719 |
| 24 | Tubing, water, 1/4" OD | 502079 |
| 25 | Hardware, mounting, evaporator cap | 00130989 |
| 26 | Solenoid, water feed (120V) | 00130823 |
| 27 | Tee, water | 00134494 |
| 28 | Sensor assembly, water level and drain clog | 00171363 |
| 29 | Cap, evaporator (includes insulation and mounting hardware) | 00130740 |
| 30 | Clip, water shut-off valve | 502922 |
| 31 | Valve, shut-off, water | 502921 |
| 32 | Auger (includes seal & O ring) | 00945725 |
| 33 | Evaporator (includes seal, (2) O rings and insulation) | 00137570 |
| 34 | Journal housing and bearing (includes (2) O rings) | 00130716 |
| 35 | Reservoir, water | 00130690 |
| 36 | Base, evaporator | 00130732 |
| 37 | Boot, solenoid | 00160309 |
| 38 | Solenoid, purge (120 V) | 00130757 |
| 39 | Insulation, evaporator | 00133876 |
| 40 | Spacers, solenoid | 00160317 |
| 41 | Elbow, 1/4" tube x 3/8" stem | 00988030 |
| Not shown | Insulation, evaporator cap | 00125468 |
| Not shown | Condensate pan | 00161612 |
| Not shown | Shuttle assembly, Micro Chewblet (includes gasket and nozzle) | 00985028 |
| Not shown | Pan, gearbox condensate (includes silicone) | 01051796 |

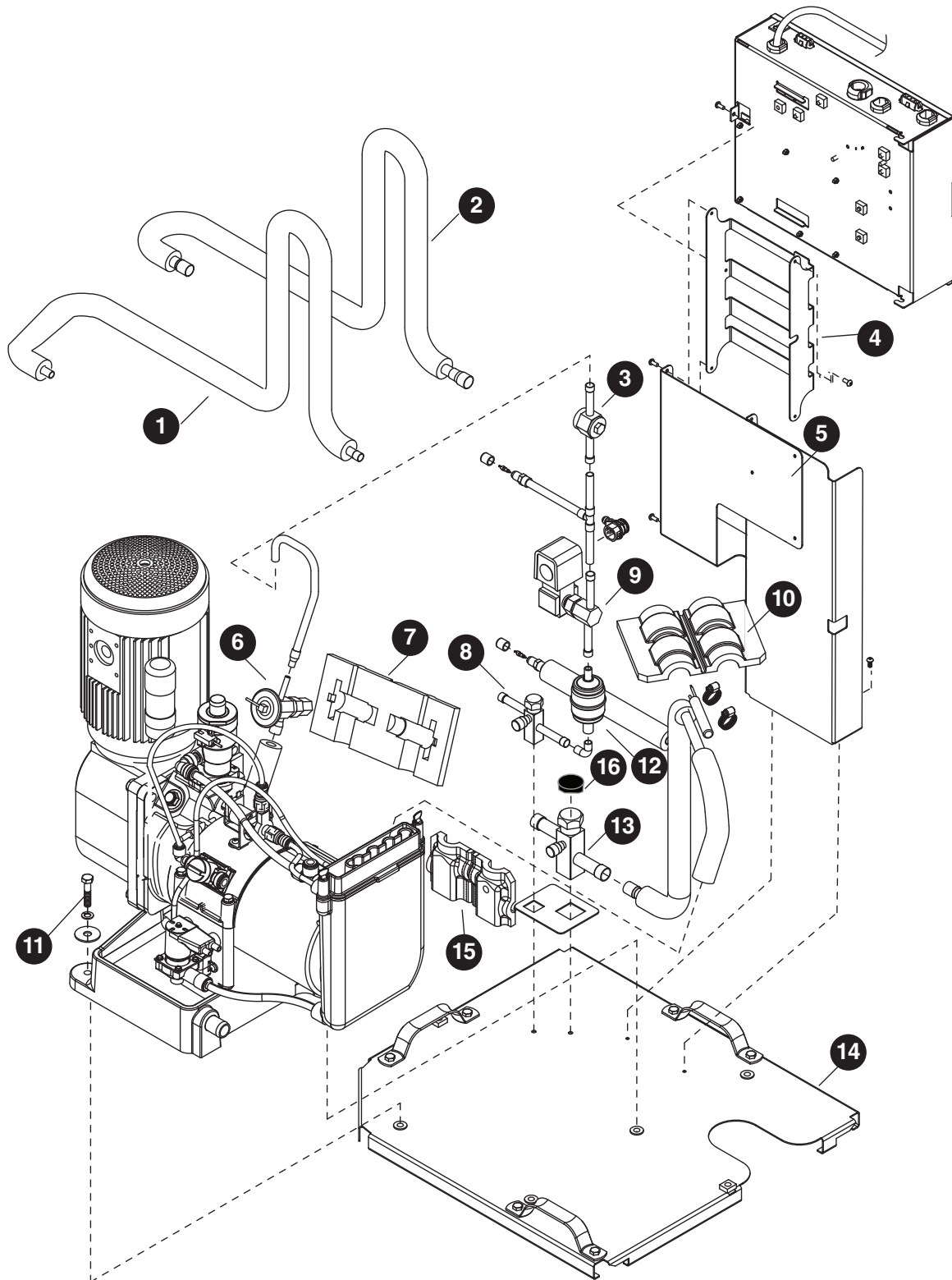

| Reference # | Description | Part # |
|-------------|---|----------|
| 1 | Tubing, liquid line (includes insulation) | 00142414 |
| 2 | Tubing, suction line (includes insulation) | 00131045 |
| 3 | Sight glass | 00107045 |
| 4 | Electrical box support | 00153635 |
| 5 | Split system support bracket assembly | 01051762 |
| 6 | Valve, expansion, thermal (includes TXV insulation and bulb insulation) | 00136317 |
| 7 | Insulation, TXV | 502830 |
| 8 | Valve, shut-off, liquid line | 00107060 |
| 9 | Valve, solenoid | 00107052 |
| 10 | Insulation, bulb, TXV | 00106534 |
| 11 | Hardware, evaporator mounting base (set of four) | 00130971 |
| 12 | Dryer | 00134593 |
| 13 | Valve, shut-off, suction line | 00107078 |
| 14 | Base, split system | 00130864 |
| 15 | Insulation, service valve | 00168914 |
| 16 | Cap, valve, shut-off, suction line | 00991026 |

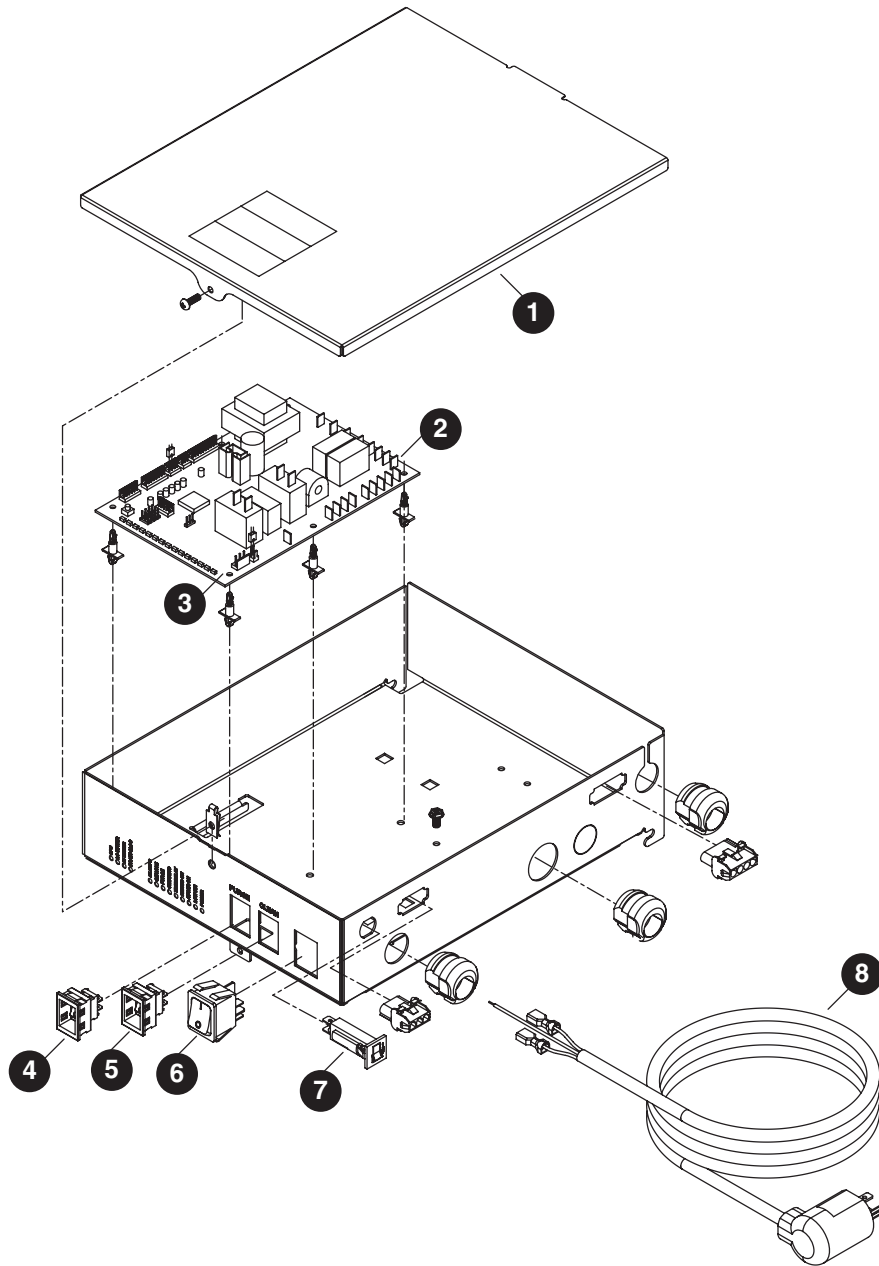

| Reference # | Description | Part # |
|-------------|---|----------|
| 1 | Cover, electrical box, remote | 00130898 |
| 2 | Board, control circuit, 120V (includes standoffs) | 00132910 |
| 3 | Stand off's (set of 6) | 00130906 |
| 4 | Switch, evaporator purge | 00114371 |
| 5 | Switch, evaporator clean | 00117036 |
| 6 | Switch, ice machine power | 208867 |
| 7 | Circuit breaker, 8A | 00128090 |
| 8 | Cord, power | 00192088 |

Top mount configuration

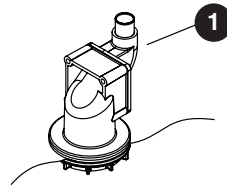
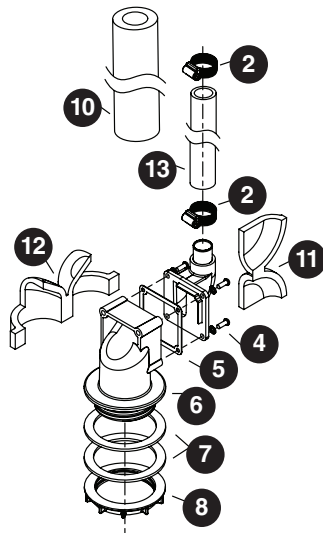

RIDE model configuration

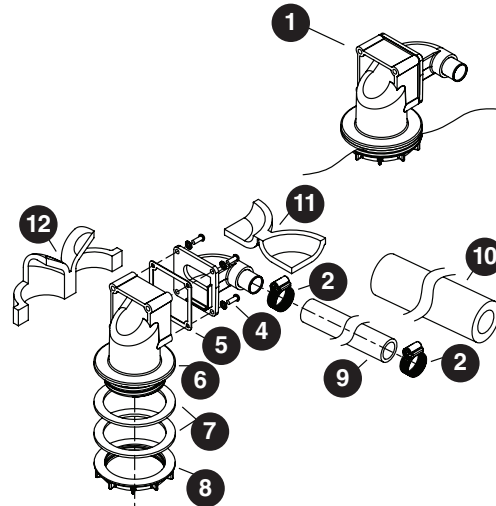

| Reference # | Description | Part # |
|-------------|--|----------|
| 1 | Shuttle actuator | 00171322 |
| 2 | Clamp | 500377 |
| 3 | Actuator elbow (includes gasket and screws) | 00171264 |
| 4 | Screws | 209100 |
| 5 | Gasket | 00167122 |
| 6 | Actuator body | 00171272 |
| 7 | Gasket, coupling | 00126532 |
| 8 | Ring, locking (includes coupling gasket) | 00171371 |
| 9 | Ice transport tube, 10' (3 m) | 00171280 |
| 9 | Ice transport tube, 20' (6 m) | 00171298 |
| 10 | Insulation, transport tube | 501176 |
| Not shown | Insulated polywire ice transport tube, per foot | 00174896 |
| 11 | Insulation, elbow | 00168922 |
| 12 | Insulation, actuator | 00168930 |
| 13 | Ice transport tube, top mount, 30" (762 mm) | 00171306 |
| Not shown | Integration kit, top mount | 00171389 |
| Not shown | Integration kit, RIDE model (includes 10' (3m) of tube and insulation) | 00171397 |
| Not shown | Extension-fill tube, 9" | 00135723 |
| Not shown | Extension-fill tube, 4" | 00153684 |
| Not shown | Diverter plate (single agitator Cornelius dispensers and left-hand dispense chute on dual-agitator Cornelius dispensers) | 307277 |
| Not shown | Diverter plate (right-hand dispense chute on dual-agitator dispensers) | 00996207 |
| Not shown | Follett SafeCLEAN ice machine cleaner (case of 24 x 7 oz packets) | 00132001 |
| Not shown | Sani-Sponge kit | 00132068 |

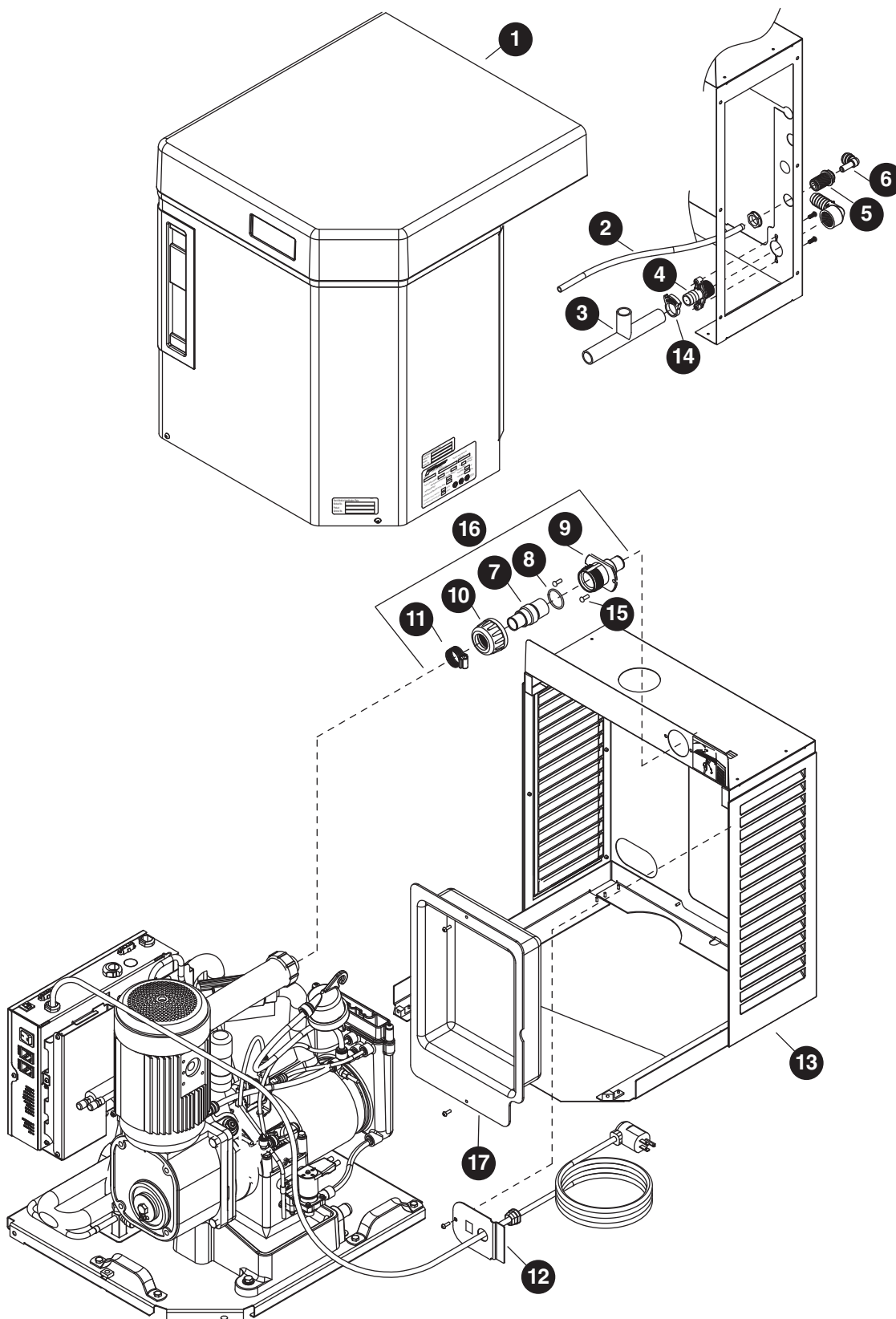

| Reference # | Description | Part # |
|-------------|---|----------|
| 1 | Front cover, split system | 00130633 |
| 2 | Tubing, water, 3/8" OD | 502719 |
| 3 | Tubing, drain | 00144923 |
| 4 | Fitting, drain | 00109728 |
| 5 | Fitting, water inlet | 502924 |
| 6 | Elbow, water inlet | 502925 |
| 7 | Coupling (includes O ring) | 00171207 |
| 8 | O ring | 00144675 |
| 9 | Bulkhead fitting | 00171215 |
| 10 | Nut | 00902338 |
| 11 | Hose clamp | 500377 |
| 12 | Plate, strain relief | 00192070 |
| 13 | Louvered docking assembly, split system (includes reference #'s 2, 3, 4, 5, 6, 9, 12, 14, 15, 17) | 00191882 |
| 14 | Clamp, drain line | 00114520 |
| 15 | Screws | 208568 |
| 16 | Bulkhead connector kit | 00171223 |
| 17 | Cover, utility access | 01017987 |

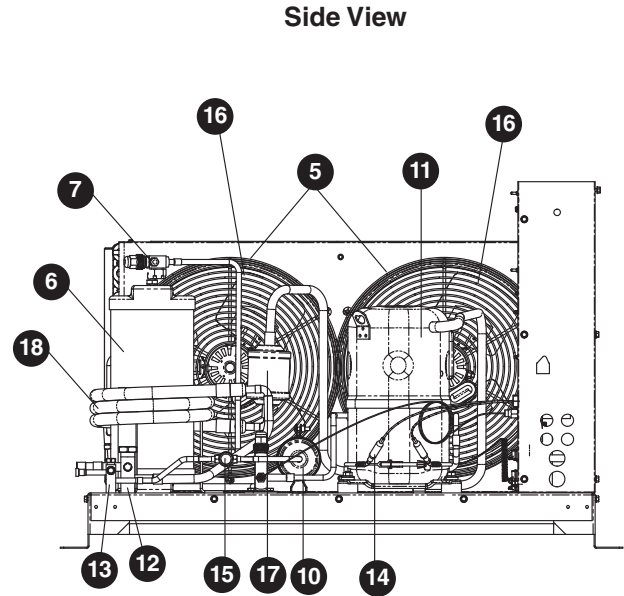
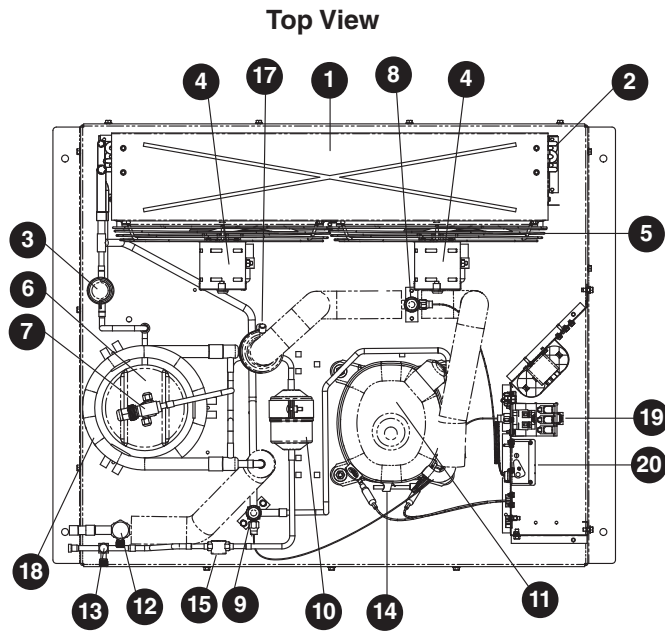

| Reference # | Description | Part # |
|-------------|---|----------|
| 1 | Shroud | 00155937 |
| 2 | Condenser | 00185843 |
| 3 | Head pressure control valve | 00110619 |
| 4 | Condenser fan motor | 00173070 |
| 5 | Condenser fan guard | 00123067 |
| 6 | Receiver | 00110627 |
| 7 | Receiver service valve | 00173047 |
| 8 | Service valve, suction line | 00185835 |
| 9 | Service valve, discharge line | 00175935 |
| 10 | Filter drier, liquid | 00175869 |
| 11 | Compressor (includes crankcase heater, start components, check valve and filter driers) | 01078864 |
| 11 | Retrofit compressor (includes receiver heater, check valve, crankcase heater and filter driers) | 01077007 |
| 12 | Shut-off valve, suction line | 00107078 |
| 13 | Shut-off valve, liquid line | 00107060 |
| 14 | Crankcase heater | 00185827 |
| 15 | Sight glass | 00175885 |
| 16 | Condenser fan blade | 00173088 |
| 17 | Filter drier, suction | 00991075 |
| 18 | Heat exchanger | 00185850 |
| 19 | Contactors | 00155952 |
| 20 | Low pressure switch | 00173104 |
| Not shown | Check valve | 00175893 |
| Not shown | Starting relay | 00110585 |
| Not shown | Gasket, receiver service valve | 00175901 |
| Not shown | Baffle, shroud | 00173096 |
| Not shown | Run capacitor | 00141689 |
| Not shown | Starting capacitor | 00185793 |
| Not shown | High pressure switch | 00173112 |
| Not shown | Fan cycling switch | 00173120 |

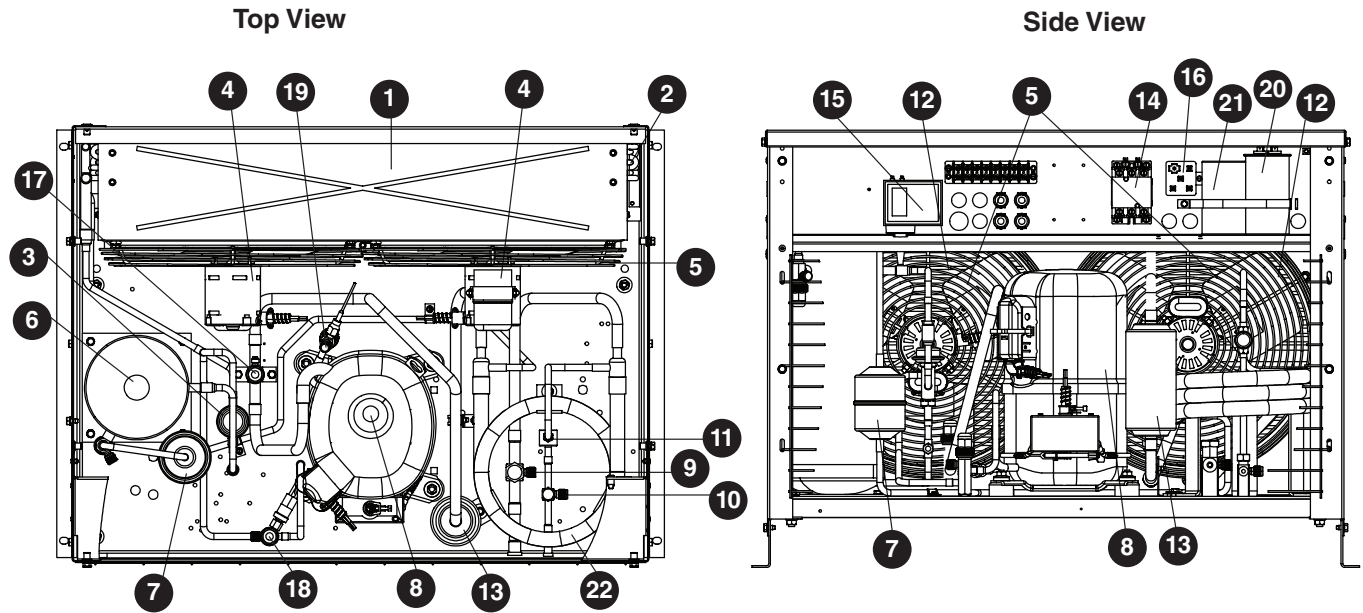

| Reference # | Description | Part # |
|-------------|---|----------|
| 1 | Shroud | 01018290 |
| 2 | Condenser | 00185843 |
| 3 | Head pressure control valve | 01021401 |
| 4 | Condenser fan motor | 01018266 |
| 5 | Condenser fan guard | 00123067 |
| 6 | Receiver | 00991034 |
| 7 | Filter drier, liquid | 00998245 |
| 8 | Compressor (includes crankcase heater, start components, check valve and filter driers) | 01078864 |
| 8 | Retrofit compressor (includes receiver heater, check valve, crankcase heater and filter driers) | 01077015 |
| 9 | Shut-off valve, suction line | 00107078 |
| 10 | Shut-off valve, liquid line | 00107060 |
| 11 | Sight glass | 01018357 |
| 12 | Condenser fan blade | 00173088 |
| 13 | Filter drier, suction | 00991075 |
| 14 | Contactors | 00155952 |
| 15 | Low pressure control | 01018316 |
| 16 | Starting relay | 00110585 |
| 17 | Suction valve | 00185835 |
| 18 | Discharge valve | 01021435 |
| 19 | Process valve | 01036821 |
| 20 | Run capacitor | 00141689 |
| 21 | Starting capacitor | 01036755 |
| 22 | Heat exchanger | 00185850 |
| Not shown | Check valve | 00175893 |
| Not shown | High pressure switch | 01018308 |
| Not shown | Fan cycling switch | 01021393 |
| Not shown | Crankcase heater | 00185827 |

Note: Overload is internal to compressor.

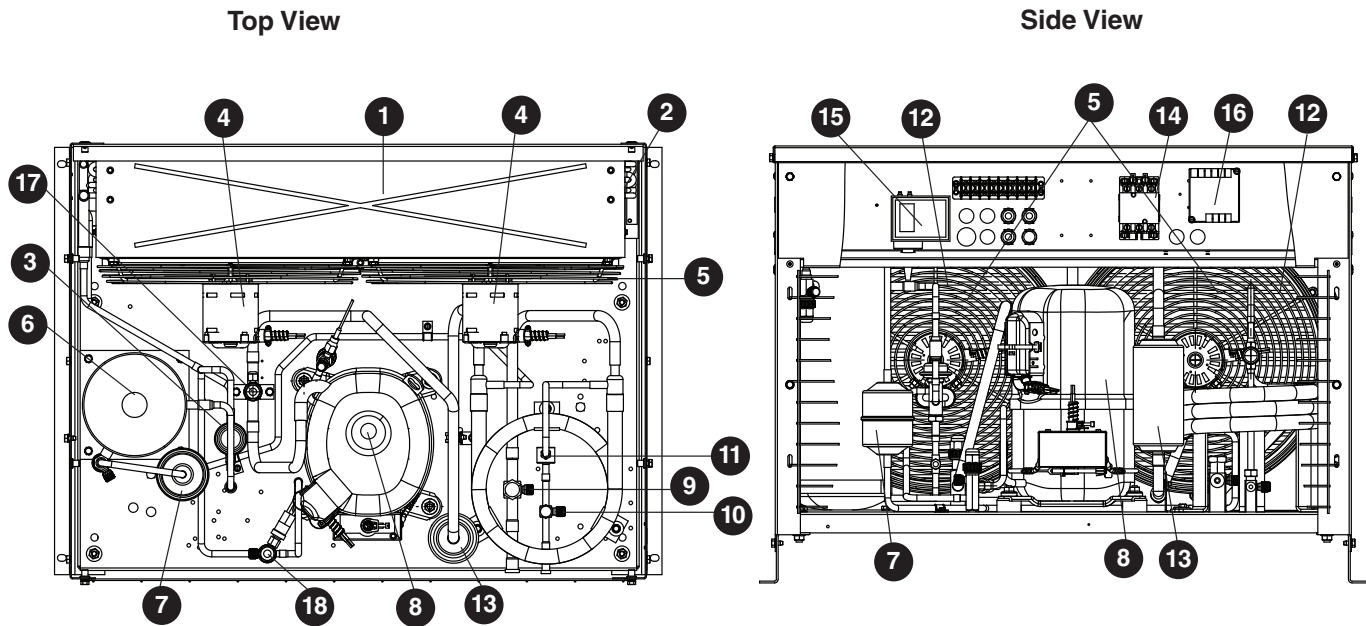

| Reference # | Description | Part # |
|-------------|--|----------|
| 1 | Shroud | 01018290 |
| 2 | Condenser | 00185843 |
| 3 | Head pressure control valve | 00110619 |
| 4 | Condenser fan motor | 01018266 |
| 5 | Condenser fan guard | 00123067 |
| 6 | Receiver | 00991034 |
| 7 | Filter drier, liquid | 00998245 |
| 8 | Compressor (includes crankcase heater, check valve and filter driers) | 01078872 |
| 8 | Retrofit compressor (includes crankcase heater, receiver heater and filter driers) | 01077023 |
| 9 | Shut-off valve, suction line | 00107078 |
| 10 | Shut-off valve, liquid line | 00107060 |
| 11 | Sight glass | 00175885 |
| 12 | Condenser fan blade | 00173088 |
| 13 | Filter drier, suction | 00991075 |
| 14 | Contactors | 00155952 |
| 15 | Low pressure control | 01018316 |
| 16 | Phase monitor | 00991117 |
| 17 | Suction valve | 00185835 |
| 18 | Discharge valve | 01021435 |
| Not shown | Check valve | 00175893 |
| Not shown | High pressure switch | 00173112 |
| Not shown | Fan cycling switch | 00173120 |

Harmony, Ice Manager, SafeCLEAN, Sani-Sponge and Vision are trademarks of Follett Corporation
Chewblet, RIDE and Follett are registered trademarks of Follett Corporation, registered in the US.