

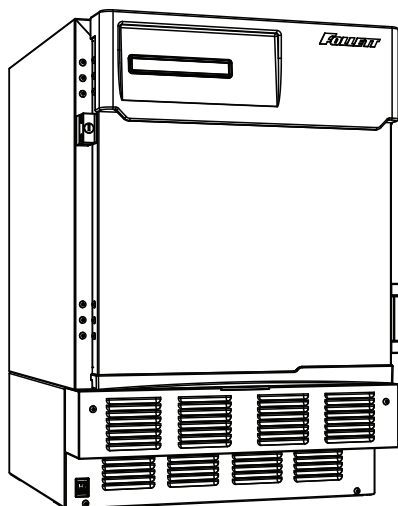

REF4P and REF5P and REF5BBP-T Performance Plus Undercounter Refrigerators

Installation, Operation and Service Manual
Serial numbers K25541 to L31321



REF4P

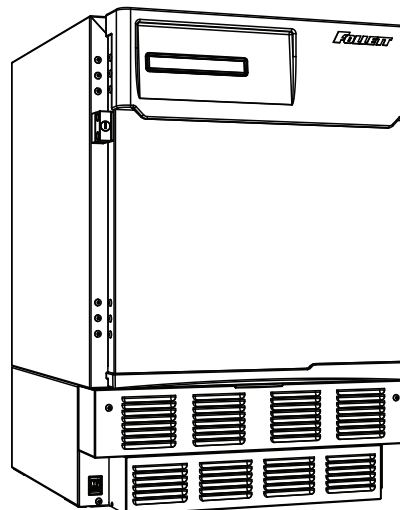

REF5P

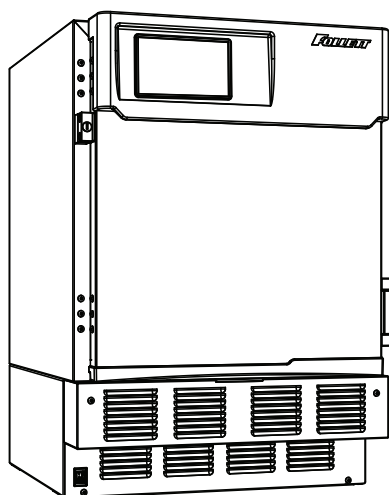

REF4P-T

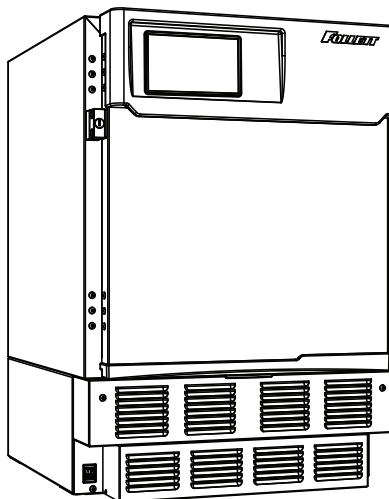

REF5P-T

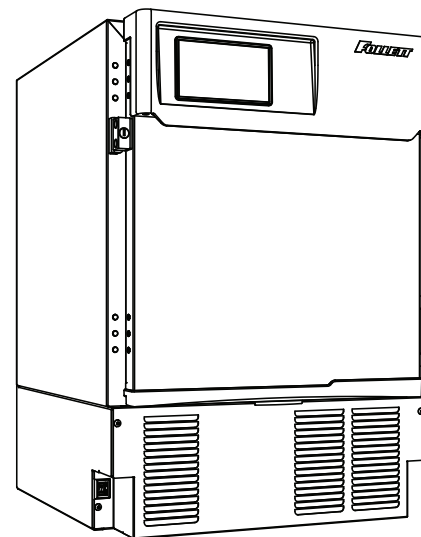

REF5BBP-T

**Following installation, please forward this manual
to the appropriate operations person.**

Contents

Welcome to Follett.....	3
Specifications	4
Electrical Specifications.....	4
Refrigeration Specifications.....	4
Installation Specifications	4
Installation	5
Installing Levelers	5
Battery Backup (Touchscreen and Keypad units only).....	5
Installing Shelves.....	6
Installing Drawer.....	6
Third-party Probe - Optional.....	6
Reversing the Door Swing – Optional	7
Installing Glycerine Solution in Product Simulation Bottle.....	10
Turn on Power.....	10
Operation	11
Temperature Control	11
Defrosting.....	11
Controller Operation - Performance Plus	12
Controller Display.....	12
Controller Security	12
Changing Temperature Display from C to F.....	12
Sleep Function.....	12
Temp Log.....	13
Alarming Functions.....	13
Follett Keypad Lock	15
Controller Operation - Performance Plus Touchscreen	17
Use and care of the LCD Performance Plus Touchscreen	17
Cleaning	28
Annual Cleaning	28
Service.....	28
Door Gasket Replacement	28
Slide-out Compressor Tray	28
Removing Drawers	29
Removing Slides.....	29
Changing the back-up Batteries	29
Controller Replacement.....	30
Wiring Diagram.....	31
Refrigeration System	32
Checking Refrigeration System Pressures	32
Compressor Information	33
Troubleshooting	34
Accessories	35
Replacement Parts.....	36
Evaporator	36
Condensing Unit	37
Hardware	39
Hardware and Electrical Components.....	40

Welcome to Follett

Follett equipment enjoys a well-deserved reputation for excellent performance, long-term reliability and outstanding after-the-sale support. To ensure that this product delivers that same degree of service, we ask that you take a moment to review this manual before beginning the installation. Should you have any questions or require technical help at any point, please call our technical service group at (877) 612-5086 or (610) 252-7301.

Before you Begin

After uncrating and removing all packing material, inspect the equipment for concealed shipping damage. If damage is found, notify the shipper immediately and contact Follett Corporation so that we can help in the filing of a claim, if necessary.

Check your paperwork to determine which item number you have. Follett item numbers are designed to provide information about the type of refrigerator you are receiving. Following is an explanation of the different item numbers.

Model Number	Item Number	User Interface		Keypad Lock	Door		Drawer
		Performance Plus	Performance Plus Touchscreen		Solid	Glass	
REF5P	REF5P-00-00	X			X		
	REF5P-00-GD	X				X	
	REF5P-KP-00	X		X	X		
	REF5P-KP-GD	X		X		X	
	REF5P-T-00-00		X		X		
	REF5P-T-00-GD		X			X	
	REF5P-T-KP-00		X	X	X		
	REF5P-T-KP-GD		X	X		X	
REF4P	REF4P-00-00	X			X		
	REF4P-00-GD	X				X	
	REF4P-KP-00	X		X	X		
	REF4P-KP-GD	X		X		X	
	REF4P-T-00-00		X		X		
	REF4P-T-00-GD		X			X	
	REF4P-T-KP-00		X	X	X		
REF4P-T-KP-GD		X	X		X		
REF5BBP-T	REF5BBP-T-00-00		X		X		X
	REF5BBP-T-00-GD		X			X	X
	REF5BBP-T-KP-00		X	X	X		X
	REF5BBP-T-KP-GD		X	X		X	X

Specifications

REF4P	31.38" (79.7 cm) H x 23.75" (60.3 cm) W x 27" (68.5 cm) D	Fits below 34" (86.4 cm) high ADA-compatible counter	3.9 cu ft capacity
REF5P	34.00" height (86.4 cm) H x 23.75" (60.3 cm) W x 27" (68.5 cm) D	Fits below standard 36" (91.4 cm) high counter	4.5 cu ft capacity
REF5BBP-T	34.00" (86.3 cm) H x 23.75" (60.3 cm) W x 27" (68.5 cm) D	Fits below standard 36" (91.4 cm) high counter	2 drawers with total storage of 40 cardboard plasma packs 300 ml/pack); max. drawer load of 35 lb (16 kg) each

Electrical Specifications

- 115 V, 60 Hz, 1 phase
- Full load: 4.1A
- Minimum circuit ampacity: 15A
- Connect to dedicated circuit, fuse or breaker
- Maximum size of branch circuit overcurrent device: 15A
- Follett recommends circuit be protected by GFCI

Refrigeration Specifications

Refrigerant	Charge Size (oz)	Maximum Design Pressures (psi)	
		High Side	Low Side
R134A	9	190	110

Installation Specifications

Ambient temperature must not exceed 39 C (100 F).

The front louvered panel must be kept free of any cabinet trim or obstructions to ensure proper ventilation of the refrigeration system.



CAUTION!

- *Equipment must be wired according to local and national electrical codes.*
- *Always disconnect power before servicing refrigerator.*

Installation

Installing Levelers

1. Remove levelers from plastic bag packed inside refrigerator (**Fig. 1**).
2. Tip refrigerator back and screw levelers in all the way to stop (they will extend 1/8" below base of REF).
3. Adjust levelers as needed to level REF in both directions. To access levelers, remove the lower front panel. Turn levelers clockwise to extend levelers.

Note: If you are using this in a food service application and installing in accordance with NSF, you must seal the unit to the floor once it is set in place. Place a 1/8" bead of NSF-approved silicone sealant (not provided) around the base of the unit.

Fig. 1

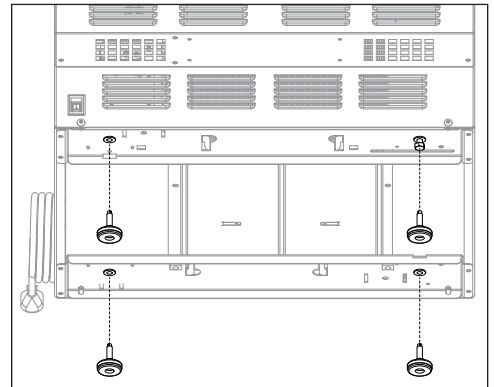

Battery Backup (Touchscreen and Keypad units only)

1. Provide power to the unit and turn the power switch to the **ON** position.
2. Open the door using the keypad lock and prop the door open so it doesn't close during the battery installation.
3. Turn power switch to the **OFF** position or unplug the unit from the power supply.
4. Remove the four screws (**Fig. 2.1**) on the kick panel at the bottom of the unit.
5. Remove the kick panel and slide the panel to the right of the refrigerator.

Note: Take care when removing, some wires are connected to the kick panel (Fig. 2.2).

6. Find the control module on the left-hand side of the unit, just to the left of the condenser.
7. Locate the battery pack wiring harness that is hanging next to the backup battery pack.
8. Connect the battery pack harness to the battery pack.
9. If a Low Battery Alarm Error is present on the controller display, acknowledge the alarm as follows:
 - Basic controller: Press and hold SET button for 3-5 seconds until RST appears
 - Touchscreen controller: Press the checkbox icon  located in the yellow alert box.
10. Re-install the kick panel.
11. Close the door and check to make sure that the wire on the hinge side of the door is not kinked or pinched.
12. Test operation of the keypad lock while the power to the unit is **OFF** to confirm back-up battery connection.
13. Turn the power switch **ON** or plug the unit back into the power supply.

Fig. 2



Installing Shelves

1. Remove shelves packed as an accessory (**Fig. 3**).
2. Place top notch of shelf bracket into pilaster, then bottom notch.
3. Press down on top of shelf to lock the shelf into the pilaster.

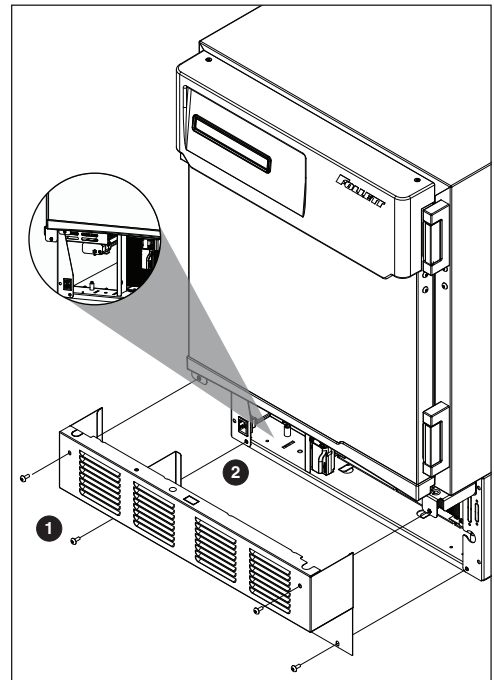
Fig. 3

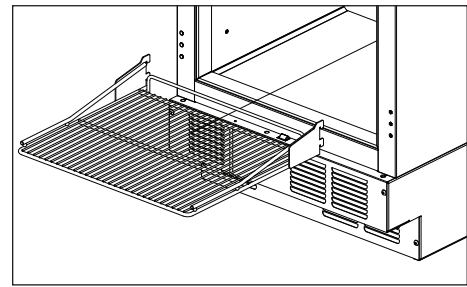

Installing Drawer

CAUTION!

- Do not use casters on units with drawers. Personal injury or damage to unit could result.

1. Remove drawer packed as an accessory (**Fig. 4**).
2. Install the two rollers to the threaded holes on each side of the inside of the cabinet.
3. Hang one drawer slide on the each side of the cabinet by holding the slide parallel to the bottom of the cabinet, tipping the slide at a 45 degree angle, and pushing the slide over the two rollers.
4. Once the drawer slides are installed, slide the two rear rollers of the drawer into the slots on the top of the lower channel of the slides. Tip up the front of the drawer and slide the back until the front drawer roller lines up to slot. Drop the front drawer roller into the channel and push the drawer all the way in the cabinet.
5. Test operation of the drawer by sliding the drawer all the way out, then back in.

Fig. 4

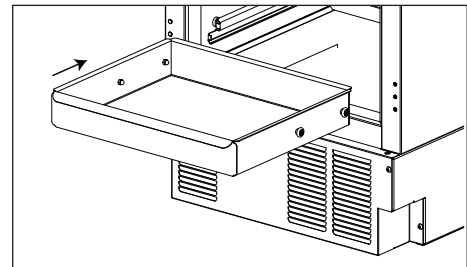

Third-party Probe - Optional

1. Locate the three sided knockout (**Fig. 5.1**) on the evaporator cover on the inside of the refrigerator, just left of the fan.
2. Push the knockout with a screw driver until it folds down.
3. Locate the yellow foam circle on the rear of the box (**Fig. 5.2**).
4. Using a screw driver, puncture a hole through the foam to make an access hole for the third-party temperature probe.
5. Fish the temperature probe through the foam circle in the back of the unit, then through the knockout on the evaporator cover.
6. Position the third party probe in the desired location in the refrigerator cabinet.
7. Use Permagem* or equivalent sealant to replace foam insulation and ensure proper performance of freezer.

* Permagem is a registered trademark of the Presstite Engineering Company.

Fig. 5

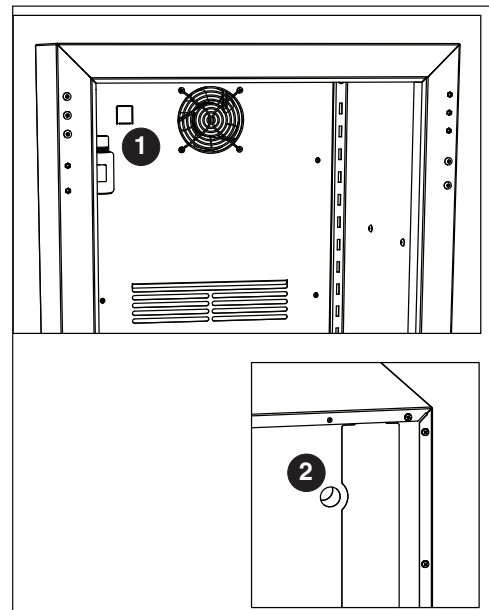

Reversing the Door Swing – Optional

Tools needed:

- #2 Phillips head screwdriver
 - Flat-head screwdriver
 - Awl
 - Gloves
 - Safety glasses
1. Turn power OFF (and, if applicable, disconnect the battery backup) prior to reversing door swing.
 2. Remove kick panel* and disconnect reed switch where applicable (**Fig. 6**).
 - * If the unit has a keypad lock, the door must be open to remove the kick panel.
 3. Find the control module on the left-hand side of the unit, just to the left of the condenser.
 4. Remove the thumb nut (**Fig. 7.1**) on the bottom front of the control module (**Fig. 7.2**).
 5. Pull control module forward 1 inch, rotate left as per Fig. 8, and continue to pull the control module forward.

Fig. 6

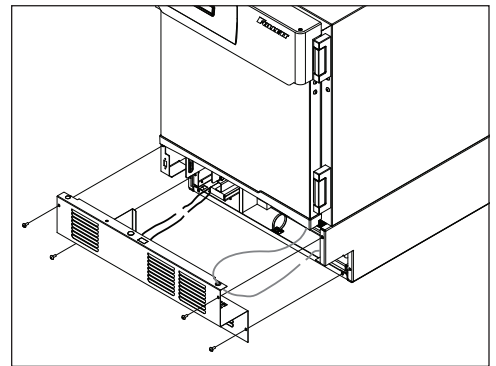

Fig. 7

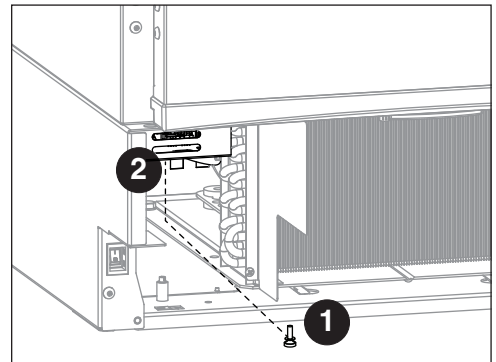
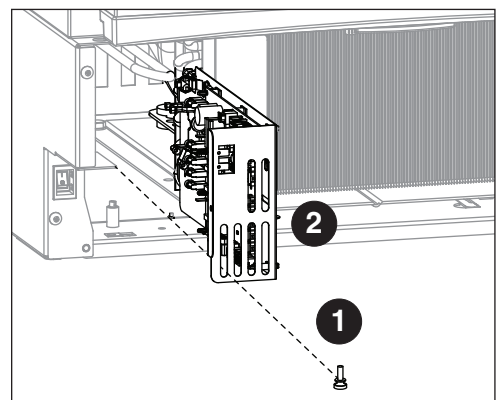

Fig. 8



6. Disconnect the door communication harness from the P10 terminal on the control board.
7. Locate the wire tie securing the door harness to the underside of the cabinet and cut.
8. Locate the ground screw in the front right-hand corner that secures the communication harness ground wire and remove. Do **not** discard the ground screw.
9. Remove the wire and strain relief from the right side panel and pull the communication harness through the opening. **(Fig. 9).**

Fig. 9



10. Remove the screw from the white strap on the hinge side of the wire channel (Carefully remove the control wire from the channel ensuring the insulation jacket does not tear.) Route through channel to opposite side of door. Reinstall the wire and strap on the opposite side of the door **(Fig. 10).**

Fig. 10

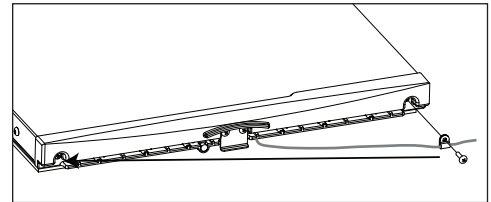

11. Use a flat screwdriver to carefully remove hinge covers.
12. Rotate top of spring assembly (clockwise for left-hand doors and counter-clockwise for right-hand doors) **(Fig. 11.1)** to remove the pin **(Fig. 11.2).**
13. Relieve torque on the spring.
14. Remove the knockout on the kick panel and move the strain relief to the opposite side.

Fig. 11

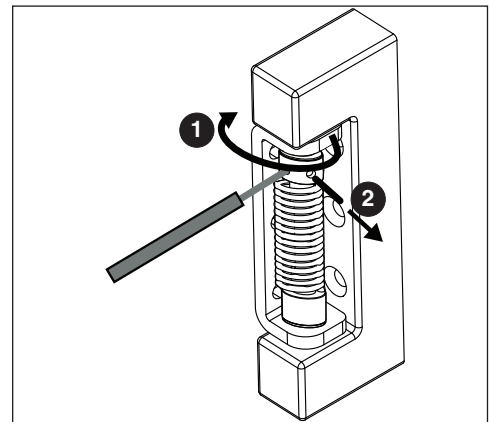

15. With flat-head screwdriver, simultaneously push down and pry the top of the spring out of the top of the hinge **(Fig. 12).**

Fig. 12

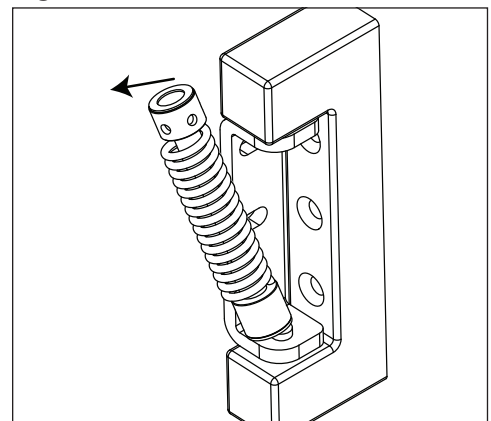

16. Remove screws and latch from refrigerator cabinet and the lock from the door (**Fig. 13**).

Fig. 13

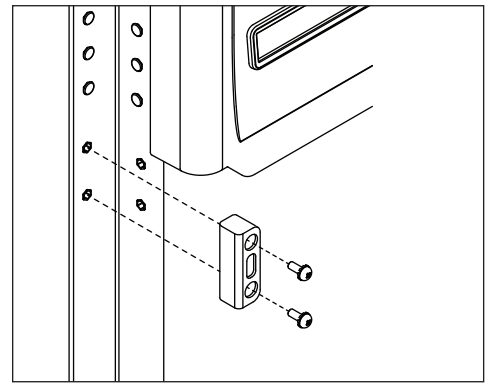

17. Support door and remove screws attaching hinge to refrigerator cabinet and remove the door (**Fig. 14**).
18. Remove the hinge from the door.
19. Remove hinge screws from opposite side of cabinet and transfer to riv-nuts now left exposed from hinge removal on both the cabinet and door side.

20. Reinstall the hinges on the opposite side of the door.

NOTE: When reversing the door the hinges must also be flipped upside down

21. Adjust the hinges on the door by pushing the loose hinges towards the gasket side of the door until the hinge is stopped by the screws. Tightened screws.
22. Remove knock out on left side panel and route door cable and strain relief through opening.
23. Reinstall the door onto the cabinet but keep the mounting screws loose temporarily.
24. Reinstall lock and strike bracket to opposite side of door/cabinet.
25. Reinstall tension spring onto top hinge and adjust for proper closure.
26. When spring is properly tensioned, door should automatically close when held open roughly 1”.
27. Reinstall hinge covers.
28. Route door cable to the P10 terminal on the control board.
29. Using ground screw from Step 7, secure the communication harness ground wire in the front left-hand corner of the base plate. The connection is approximately 2" from the left side and 0.5" from the front.
30. Reinstall control module.
31. Reinstall kickplate.

Fig. 14

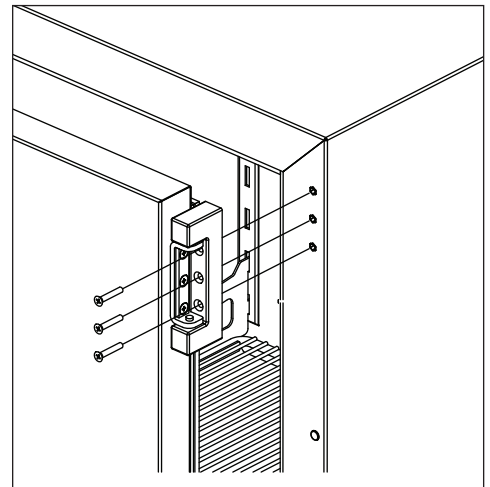

Installing Glycerine Solution in Product Simulation Bottle

(glycerine not included - P/N00959296)

1. Remove the bottle from the bracket located in the upper left side of the refrigerator (**Fig. 15**).
2. Remove the top and fill the bottle with a 50/50 solution of glycerine and water.
3. Replace the top (and probe).
4. Reinsert bottle into the bracket.

Note: If you are using this in a food service application, and installing in accordance with NSF, you must remove the probe from the bottle. NSF requires that air temperature be displayed.

Fig. 15



Turn on Power

1. Move power switch, located on the bottom left of unit, to the ON position.

Fig. 16

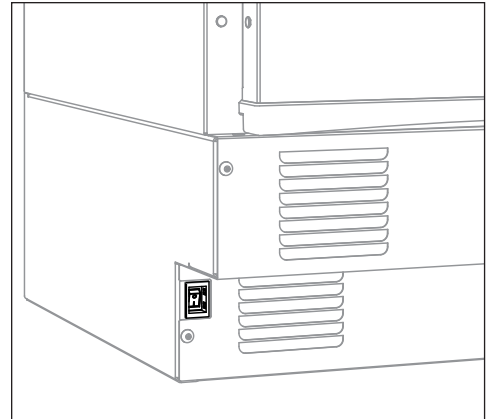

Operation

The temperature control board and probe indicate when the refrigeration system is required to turn on and off.

The refrigeration system removes heat from the cabinet interior and rejects it to the surrounding room air. When the cabinet interior temperature rises above the controller cut-in temperature, the controller turns the refrigeration system on. The controller energizes the evaporator fan and solid-state control relay which energizes the condensing unit. The compressor uses a current-style starting relay and a starting capacitor to start the compressor motor.

When the cabinet interior falls below the predetermined cut-out temperature, read by the P1 (control probe), the controller de-energizes the solid state compressor relay and condenser fan motor. The additional evaporator fan run-time is dependent upon the delay setting programmed within the controller menu.

Any accumulated frost on the evaporator coils melts during the off cycle. The condensate drains out of the unit to the condensate tray to the left of the condensing unit. The heat from the condensing unit evaporates any condensate in the drain pan.

Temperature Control

The temperature control system is preset by the factory to maintain a product temperature of 4.4 C (40 F). If desired, the set-point temperature can be raised as high as 10 C (50 F) by following the instructions in Controller Operation on page 8 for changing the temperature set point.

Defrosting

Performance Plus undercounter refrigerators do not require manual defrosting. The unit cooler defrosts automatically when the condensing unit is in the OFF cycle and during an off time defrost every 8 hours. The defrost will terminate when the cabinet temperature read via the P1 control probe reaches 3.3 C (38 F) or after 60 minutes.

Controller Operation - Performance Plus

In normal operation, the controller displays product temperature in degrees C (default) or user-selected degrees F. The controller is pre-programmed with a 4.4 C (40 F) set point. **COMP** displays when the compressor is running. If this set point does not meet your specific application needs, instructions for changing the set point are found below.

Note: Follett presets its refrigeration system to hold product temperature at approximately 4.4 C (40 F). If you are using this in a food service application, and installing in accordance with NSF, you must set the control set-point to 3.3 C (38 F). This will deliver a product temperature below the 4.4 C (40 F) NSF requirement.

Controller Display

The controller display will show the product/bottle temperature in degrees C or degrees F as selected by the user except when the unit is in an alarm.

The controller has system indicators above the temperature display to let you know when: the compressor is energized (**COMP**), the evaporator fan is energized (**FAN**) or the unit is in defrost (**DEF**).



To display temperature Set-point		
Step	Input	Display
1	Press and release SET	Current set-point temperature will display for approximately 5 seconds. Display will return to current product temperature.

To change temperature Set-point		
Step	Input	Display
1	Press and hold SET for 3 seconds	Set-point will flash.
2	Press UP or DOWN arrows to desired set-point	New temperature set-point will flash on the display.
3	Press and release SET to accept	Product temperature will display.

Controller Security

The controller can be locked so that the set-points in the controller cannot be changed.

1. To lock, press **UP** and **DOWN** arrows simultaneously until **LOC** appears (approximately 5 s).
2. To unlock the controller, press up and down arrows simultaneously until **UNL** appears. Changes are only accepted when the controller is unlocked.

Changing Temperature Display from C to F

1. Press **SET** and **UP** arrow simultaneously until **L1** is displayed.
2. Press the **UP** arrow until **UNT** is displayed. Press **SET** then use the **UP** and **DOWN** arrows to change the temperature display from C to F. Press **SET** to accept. The display will return to the temperature in approximately 10 s.

Sleep Function

Press the **SLEEP** button to blank the display, or press any button to wake the display. If the unit goes into an alarm, the display will wake to display the alarm.

Temp Log

High and low log display

1. Press the **UP** arrow to display the highest temperature the refrigerator has recorded since last reset or power cycle.
2. Press the **DOWN** arrow to display the lowest temperature that the refrigerator has recorded since last reset or power cycle.

Reset high and low log

1. Press **UP** or **DOWN** arrow until recorded temperature is displayed.
2. Press and hold **SET** until **RST** is displayed.

Alarming Functions

Set high and low alarms

1. Press and hold **SET** and **UP** arrows simultaneously until **L1** is displayed. Use the **UP** and **DOWN** arrows to navigate parameters.
2. The **low** temperature alarm parameter is **AIL**. Once the parameter is displayed, press **SET** to display the low alarm temperature. The alarm temperature will flash on the display. Use the **UP** and **DOWN** arrows to set the alarm temperature. Press **SET** to accept.
3. The **high** temperature alarm parameter is **AIH**. Once the parameter is displayed, press **SET** to display the high alarm temperature. The alarm temperature will flash on the display. Use the **UP** and **DOWN** arrows to set the alarm temperature. Press **SET** to accept.

Start-up alarm delay

The Performance Plus unit has a 120 minute time delay between when the unit is energized to when the temperature alarms become active. This delay can be change in parameters in the controller under **Alarm Startup Delay (ASd)**.

Mute the Alarms

The mute button is used to temporarily mute the audible alarm for 10 minutes. If the alarm condition of the unit has not changed in 10 minutes, then the alarm will sound again.

Alarm acknowledgement and alarm Reset

The alarm will need to be acknowledged after the alarm condition has been resolved, before the alarm will reset. To acknowledge the alarm press and hold set until the RST is displayed.

Alarming Contacts (Touchscreen units only)

This unit is equipped with dry contacts that may be connected to a 3rd party monitoring system. The contacts are located on the back of the unit. Standard Performance Plus units utilize the Alarm 1 set (top 3). Each set of dry contacts has a Common, a Normally Open and a Normally Closed connection point. By default, Alarm Relay 1 is set to activate with any of the following alarms: Alarm 1 High temp, Alarm 1 Low temp, System errors or probe error.

Probe calibration

The temperature probes can be calibrated from **-9.9 to +9.9**. The calibration is in the second level menu under **P1C** (control probe) and **P3C** (Alarm).

Alarm Codes

When the unit senses an alarm, the display will flash the following codes.

Value	Description
HA1	Temperature is above the High Alarm#1 set point.
LA1	Temperature is below the low Alarm #1 set point.
HA2	Temperature is above the High Alarm #2 set point.
LA2	Temperature is below the Low Alarm #2 set point.
DFA	Defrost time out (lasted the full 30 minutes)
Lob	Low battery alarm.
dA	Door open alarm.

Error Codes

Value	Description
P1-P3	Controller is not sensing the probe.
F9	Error saving new parameter values to permanent storage.
F10	Incomplete model configuration.
F11	Number/membrane is sticking.
F21	Key shorted on user interface.
F22	Communication error with user interface.
F23	Communication error with Machine Control.

Advanced Settings

The refrigerator can be further customized through the first level (L1) and second level parameters (L2) in the chart below.

1. Press and hold **SET** and **UP** arrows simultaneously until **L1** is displayed.
2. Use the **UP** and **DOWN** arrows to navigate the parameters. When the desired parameter is displayed, press **SET**.
3. Use the **UP** and **DOWN** arrows to navigate the sub menu of the parameter. Press **SET** to accept and the display will return to the parameter list (after 30 seconds the display will return to the temperature display).

Parameter	Display	Description
Beeper Function	bPr	Controls the audible beeper function on the controller. Off, All, door, Alarm, Error.
Beeper Volume	bPu	Sets the volume of the beeper: 0 (minimum) to 10 (maximum).
Button Clicks	btc	Sets if a beep should sound each time a button is pressed. Yes or No .
Sleep Function	SLP	Determines if sleep function activated from the panel. Yes or No .
Sleep Timer	SLt	Amount of time before the screen blanks automatically. 0 s to 600 s .
Alarm1 High Temp	A1H	High temperature to activate alarm1. User set point to 121 C (250 F).
Alarm1 Low Temp	A1L	Low temperature to activate alarm1. User set point to -46 C (-50 F).
Alarm1 Probe	A1P	Probe for Alarm. P1 (cabinet air), P3 (simulation bottle).
Units	unt	Display temperatures in degrees C or F. F or C .

1. Press and hold **SET** and **UP** arrows simultaneously until **L1** is displayed.
2. Press and hold **SET** and **UP** arrows simultaneously again until **L2** is displayed.
3. Use the **UP** and **DOWN** arrows to navigate the parameters. When the desired parameter is displayed, press **SET**.
4. Use the **UP** and **DOWN** arrows to navigate the sub menu of the parameter. Press **SET** to accept and the display will return to the parameter list (after 30 seconds the display will return to the temperature display).

Parameter	Display	Description
Alarm1 Delay	A1d	Alarm1 delay before sounding. 0 to 60 minutes
Alarm1 Function	A1F	Defines the action taken when Alarm2 is activated. NO (normally open), NC (normally closed), R1 (activate relay), R2 (not used), DIS (disable).
Alarm1 Reset	A2r	Temperature difference to reset alarm1. 0 to 10 degrees.
Alarm2 Delay	A2d	Alarm1 delay before sounding. 0 to 60 minutes.
Alarm2 Function	A2F	Defines the action taken when Alarm2 is activated. NO (normally open), NC (normally closed), R1 (activate relay), R2 (not used), DIS (disable).
Alarm2 Reset	A2r	Temperature difference to reset alarm1. 0 to 10 degrees.
Alarm Ring back	Arb	Defines the time delay until the alarm will resound. 0 to 120 minutes
Alarm Startup Delay	ASd	Defines the alarm delay during startup. 0 to 180 minutes.
Alarm Silencing	ASL	Determines if the alarms can be silenced or not. Yes, No.
Maintain Alarm	nAL	Determines if the alarm (1-3) should be maintained if the temperatures fall back into range. Yes, No.
Probe 1 Calibration	P1C	Offset value for probe 1 calibration. -9.9 to 9.9 .
Probe 3 Calibration	P3C	Offset value for probe 3 calibration. -9.9 to 9.9 .
Controller Parameter Reset	rSt	Reset to restore factory parameters.

Follett Keypad Lock

Default user passcode for first-time users

User Code 01 is factory set by default to **1 2 3 4 5 6**.

Note: In order to continue using 1 2 3 4 5 6 as a default, user-selectable programming codes must be stored in slots 02 to 40.

User Codes 02 to 40 do not have any codes set up and are available for user-programming.

Each time a button is pressed, a chirp will be heard.

To Change the Master Code

The master code is needed to add or change the individual user codes. By default, the master code is set to **1 2 3 4 5 6**.

The master code is stored in User ID # 99.

1. Press **3 6 5**, the *****, followed by the current Master Code, followed by **ENTER** (5 Chirps will be heard).
2. Press **9 9**, followed by **ENTER**. (3 chirps will be heard).
3. Enter the new master code, followed by **ENTER** (3 chirps will be heard).
4. Re-enter the new master code, followed by **ENTER**. (5 chirps will be heard).
 - Pressing [**CANCEL**] at any point will cancel the routine.

To Enter or Change a User Code

1. Press **3 6 5**, the *****, followed by the Master Code, followed by **ENTER**. 5 Chirps will be heard.
2. Enter the user ID (a two digit code from 00 to 40), followed by **ENTER**. 3 chirps will be heard.
3. Enter the new user code (4 to 6 numbers), followed by **ENTER**. 3 chirps will be heard.
4. Re-Enter the new User Code, Followed by **ENTER**. 5 chirps will be heard to acknowledge that a new code was entered.

Example: To enter a new user code of 4 4 3 3 5 5 for ID # 15

1. Press **3 6 5 * 1 2 3 4 5 6 [ENTER]** (5 chirps will be heard).
2. Press **1 5 [ENTER]** (3 chirps will be heard).
3. Press **4 4 3 3 5 5 [ENTER]** (3 chirps will be heard).
4. Press **4 4 3 3 5 5 [ENTER]** (5 chirps will be heard).

The new code has been entered for the ID.

To Delete a User Code

1. Press **3 6 5**, the *****, followed by the Master Code, followed by **ENTER**. 5 Chirps will be heard.
2. Enter the user ID to clear, followed by **ENTER** (3 chirps will be heard).
3. Press **3 3 5, #** (3 chirps are heard) (335 = DEL).
4. Enter the user ID to clear, followed by **ENTER** (2 chirps will be heard).
5. Press **3 3 5, #** (5 chirps are heard).

The code assigned to that user ID has been deleted. If an error is encountered, the control will beep continuously for 3 seconds. The Master Code stored in user ID 99 cannot be deleted.

Example: To delete the user code in ID 15:

1. Press **3 6 5 # 1 2 3 4 5 6 [ENTER]** (5 chirps will be heard).
2. Press **1 5 [ENTER]** (3 Chirps will be heard).
3. Press **3 3 5, #** (3 Chirps will be heard) (335 = DEL).
4. Press **1 5 [ENTER]** (2 Chirps will be heard).
5. Press **3 3 5, #** (5 Chirps will be heard).

Controller Operation - Performance Plus Touchscreen

Use and care of the LCD Performance Plus Touchscreen

















The LCD touchscreen utilizes capacitive touch technology. This will allow you to engage the functionality by touching the screen with your fingers, even while you are wearing latex or cotton gloves. Functionality will not engage by touching with an inanimate object, such as a pen.

- To preserve optimal touch sensitivity, keep the screen clean by using a clean, dry cotton cloth.
- Do not expose the screen to liquids or excessive dust, heat or humidity.

Control function icons and navigation buttons engage functionality of the user interface. Status indicators alert the user to a change of status.

Home screen

The Home Screen consists of three primary information areas: the temperature display, control function display zone and system status display.

Control Functions	System Status	Functions and Settings
 Settings	 Compressor is running	 USB download available (downloading when blinking)
 Alarming	 Evaporator fan is running	 Refrigeration set points
 Light	 Door is open	 Sleep functions
 Information log	 Defrost cycle is in process	 Centigrade to Fahrenheit
 Help		 Probe set points
		 Alarming functions
		 Alarm mute
		 Reset

- Product temperature is displayed in the upper right corner.
- Primary control function icons are displayed in the lower left corner.
- System status icons will display in lower right corner to indicate a condition has been activated.

Fig. 17

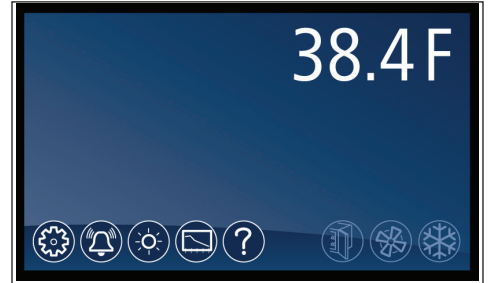





Fig. 18



High and low temperature display

From the home screen touch the temperature display in the upper right corner. The high/low temperatures will appear below the temperature display. To the left of the high/low temperature a time and date stamp will be displayed.



Reset the high and low temperatures

Touch the temperature display a second time and the reset function  will appear under the high and low temperature. Touch the reset icon and a yellow message box will appear. Press  to confirm reset or  to cancel.

Alarm set point display

From the home screen touch the temperature display three times. The High and low alarm set point will appear under the temperature.

Help

- Help is available at any time by touching the  icon at the bottom of the screen.
- Help is screen-specific; touching the  icon will display an explanation of the functionality and use of the screen you are currently viewing.
- Touch  to exit help screen.

Settings









- Refrigeration Set Point 
 - Touch the number displayed in the box to the right of the Set point label and use the keypad or **UP** and **DOWN** arrows to select product temperature between 1 C (36 F) and 10 C (50 F). Press  to accept or  to cancel.
- Sleep Temperature Display 
 - Toggle **ON** to hide the temperature reading immediately on the home screen.
- Set the Sleep Delay 
 - To automatically hide the temperature after 0-600 seconds of inactivity, touch the box to the right of the delay (0-600) box. Use keypad or **UP** and **DOWN** arrows to select from 0-600.
- Temperature
 - Toggle between **F** and **C** to select Fahrenheit or Celsius.
- Brightness 
 - Touch the number displayed in the box to the right of the Brightness  icon and use the keypad or **UP** and **DOWN** arrows to select from 1-10. Press  to accept or  to cancel.

Fig. 19

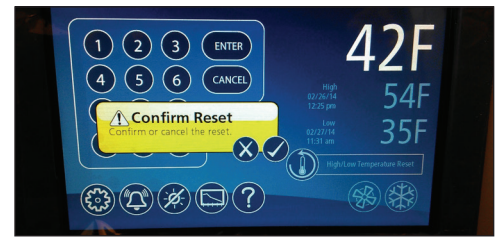

Fig. 20



Fig. 21

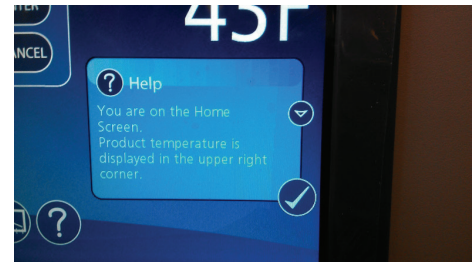

Fig. 22

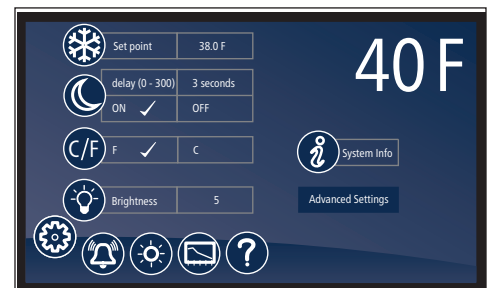

Fig. 23



System Information



- Touch the System Info icon  to display the model number, unit serial number and software version. Touch the checkbox icon  in the lower right corner of the box to clear.

Fig. 24



Alarm or Alert Notifications





- If an alarm or event condition is detected and an alarm is engaged, an alert notification will appear in the left center of the screen with an explanation of the alert condition and a checkbox  at the bottom right of the alert box.
- No further action can be taken on the User Interface until the alert condition is acknowledged and cleared by touching the checkbox .
- Mute 
 - Touch the  icon to mute audible alarm for 15 minutes.

Fig. 25



Door Switch

- The Performance Plus touchscreen units have a door switch that is located on the kick plate. The door switch will turn on the LED light and turn off the evaporator fan. If the door is open for more than one minute it will also cycle off the compressor. When the door is closed the evaporator fan and compressor will return to service.

Door Alarm

- The Performance Plus touchscreen units have a door alarm that is factory set for one minute. The alarm will clear when the door is closed. The door alarm activation time can be changed from 0-600 seconds in advanced setting under Door Open Alarm Delay.









Power Alarm

- The Performance Plus touchscreen units have a Power Alarm that will sound if the unit loses power for more than five minutes. The Power loss alarm box will display every five minutes, then the screen will sleep. An audible alarm will sound every 30 seconds during the power failure. An alarm box will be displayed when power is restored. The event log will record the exact time and date of the power loss and when the power was restored.

Start-up alarm delay

The Performance Plus unit has a 120 minute time delay between when the unit is energized to when the temperature alarms become active. This delay can be changed in parameters in the controller under **Alarm Startup Delay**.

Setting Alarms

- Alarming Settings control the conditions and timing of event and alarm conditions that result in audible and/or visual alerts.
- To change the high alarm set point, touch the number displayed in the box to the right of the  icon and use the keypad or **UP** and **DOWN** arrows to select an alarm value. Press  to accept or  to cancel.
- To change the low alarm set point, touch the number displayed in the box to the right of the  icon and use the keypad or **UP** and **DOWN** arrows to select alarm value. Press  to accept or  to cancel.
- Audible Alarm 
 - Toggle between **ON** and **OFF** to engage and disengage the audible alarm function.
- Mute 
 - Touch the  icon to mute audible alarm for 15 minutes.

Alarming Contacts

This unit is equipped with dry contacts that may be connected to a 3rd party monitoring system. The contacts are located on the back of the unit. Performance Plus touchscreen units utilize Alarm 1 set. Each set of dry contacts has a Common, a Normally Open and a Normally Closed connection point. By default, Alarm Relay 1 is set to activate with any of the following alarms: Alarm 1 High temp, Alarm 1 Low temp, Door Open Alarm, and Power Loss Alarm.

Probe calibration

The temperature probes can be calibrated from **-9.9 to +9.9** in the advanced setting on the touchscreen models (**P1**) Control and (**P3**) Alarm.

Screen saver

The screen saver will replace the home screen and display a blank screen, time and date, or the temperature. When the screen is touched or the unit has an alarm or event, it will return to the home screen. The screen saver can be changed in the advanced setting.

Screen saver function: blank, time and date, or temperature.

Screen saver time (sec): 0—600 seconds between the last touch of the screen to the activation of the screen saver.

Fig. 26



Fig. 27

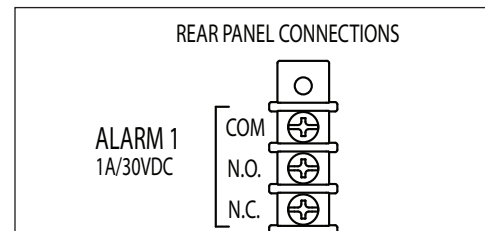

Information Logs

- All available graphs, data logs and event logs are accessed through the Information Logs function. The home screen in the Information Logs section displays the product (P3) temperature graph with one week's data. Date and time information is displayed on the horizontal axis.
- The Performance Plus units come factory set to display only the product temperature (P3) on the graph. All of the probes on the Performance Plus unit can be viewed on the graph if desired. Probes can be added to the graph through the advanced setting under P1 to P3 by selecting the probe and changing the parameter from No to Yes. The selected probe will now display on the graph.
 - P1 control, P3 Alarm
- Zoom in (+) or Zoom out (-) on an event/temperature on the home screen will change the time scale.
- Using the left and right arrows below the graph will scroll the graph. All the stored temperature data on the graph is viewable.
- Temperature Log – to display a chronological listing of logged temperatures (latest logged temperature will display first), touch the “Temperature Log” label to the left of the screen. Use the UP and DOWN arrows to the right of the screen to scroll through the logged temperatures.

Fig. 28

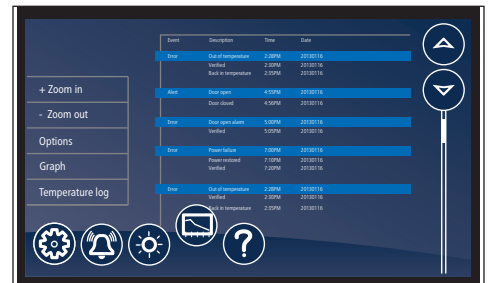

Fig. 29



- Event Log – to display a chronological listing of events (including errors, alarms and alerts), touch the **Event Log** label to the left of the screen. Use the UP and DOWN arrows to the right of the screen to scroll through the logged temperatures.

Fig. 30



Keypad access log - download only

Insert USB stick and tap Keypad Log to view. File downloads as an excel compatible .csv file.

Data logging

- The Performance Plus controller is capable of storing up to 50,000 readings per probe. The factory setting for the sample rate is every 15 minutes, which will provide enough storage for 520 days. The sample rate can be change to provide data logging for a longer or shorter time interval by changing the **Sample Rate (Min)** in the advanced settings menu. **0 = off and 360 minutes maximum.**

Data Storage

- Data can be captured different ways. The factory default is for the data to overwrite itself when the memory is full. This can be changed in the advanced setting under **Data storage overwrite**. When this parameter is set to **No**, the system will display an alert when the memory is 75% full. To clear the alert the data must be downloaded.

Data duration alarm

- A reminder can be set to download the data in the **Data duration alarm** in the advanced setting. The data duration can be set from **1 to 180 days**. If the data duration alarm is used, then the **Alarm on data full** parameter in the advanced setting must also be set to **Yes**.

Downloading data

- The touchscreen has the capability of downloading the temperature data and event log via a USB port on the left side of the user interface. The file is a CSV format and is suitable for import directly into Microsoft Excel.

- Insert the storage device in the USB slot located to the left of the Touchscreen.
- Select the Graph icon along the bottom of the Touchscreen.
- Select the USB icon in the lower right hand corner.
- A yellow alert box with **downloading data** will appear.
- Press to accept or to cancel.
- After the unit is done downloading a second yellow alert box will appear asking if you want to **Erase log**.
- Press to accept or to cancel.

Note: If you chose to erase the data, the data duration timer and the data full alarm will reset. It will also erase the information that is stored on the graph.

One of the two files below will be downloaded depending on which screen is being viewed:

EL XXXX YY - Event Log

TL XXX YY - Temperature Log

XXXX = last 4 digits of serial number

YY = 0-99 number of downloaded file

Data download reminder and data full alarm

- If you plan or are required to download data for a certain time period, you can set a **download data reminder** on the Performance Plus unit. Download data reminder can be found in the advanced setting under **Data duration** and can be set from **1 to 180 days**.

Follett Keypad Lock

For units enabled with keypad and electronic lock feature, keypad will be displayed on left side of screen.

Default user passcode for first-time users

- Master User Code 01 is factory set by default to **1 2 3 4 5 6**.
- User Codes 01 to 40 are available for user-programming.
- Each time a button is pressed, a chirp will be heard.
- See Page 12 for detailed Follett Keypad Lock instructions.

Fig. 31

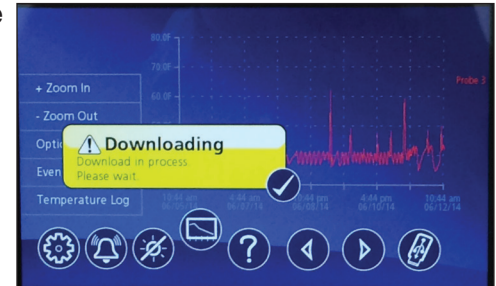

Fig. 32



Fig. 33



Changing and Adding the User Codes







1. Touch Settings  icon.
1. Touch **Advanced Settings**, enter your 4-digit user access code (factory default is 1 1 1 1) in the keypad that appears, and touch the checkmark icon  to access advanced settings screens.
2. Time and date will be displayed. Scroll using the **UP** and **DOWN** arrows until **Change Access Code** is displayed in the Display Setup screen.
3. Touch **Change Access Code** and enter the master code [ENTER]. (By default, the master code is 1 2 3 4 5 6.)
4. Touch the screen to the right of the user code 1 to 40 to overwrite or add the user code.
5. Enter the new code. Press  to accept or  to cancel.
6. Enter the new code again. Press  to accept or  to cancel.
7. Press **DONE** when finished entering access codes.

Fig. 34

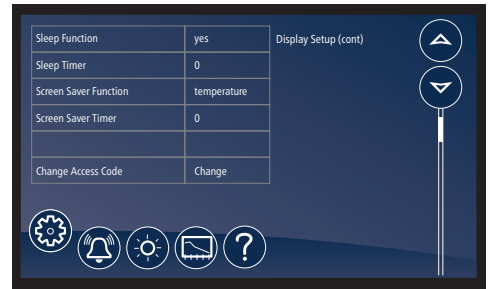
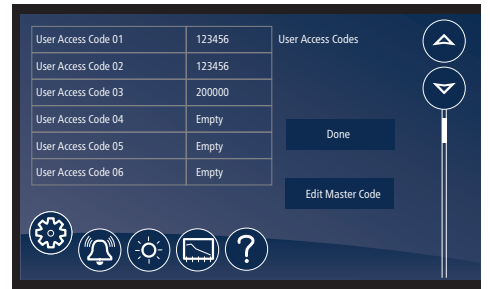

Fig. 35



Light

- To turn the interior light on (or off), touch the Light icon or the Light Off icon.
- Light timer is in advanced settings.
- The light will also come on when the door is open

Time and Date













- To set time and date, press the Settings  icon.
- To display options, touch **Advanced Settings**, enter your 4-digit user access code in the keypad that appears, and touch the checkmark icon  to access advanced settings screens (factory default is 1111).
- Time: touch displayed time and use the keypad to enter the time. Press  to accept or  to cancel.
- AM/PM: touch displayed value to toggle between AM and PM.
- Month: touch number displayed and use the keypad to enter the month. Press  to accept or  to cancel.
- Day: touch number displayed and use the keypad to enter the day. Press  to accept or  to cancel.
- Year: touch number displayed and use the keypad to enter the year. Press  to accept or  to cancel.

Fig. 36

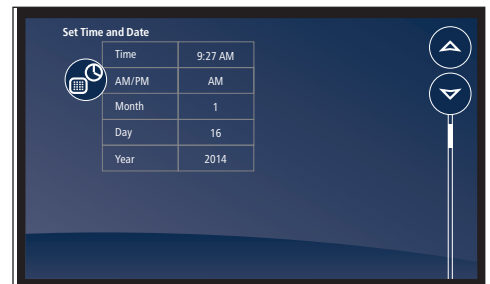

Advanced Settings

- Touch **Advanced Settings**, enter your 4-digit user access code in the keypad that appears, and touch the checkmark icon  to access advanced settings screens (factory default is 1111).

Advanced Setting - Touchscreen

Parameter	Default Value	Range	Description
Set Time and Date			
Time	7:45	0-12	Holds Hour
AM/PM	AM	AM, PM	Holds AM/PM
Month	12	1-12	Month
Day	16	1-31	Day
Year	2013	2010-2099	Year
System Information			
Serial Number	E12345	—	—
MC Version	33	—	MC version
EMC version	2	—	EMC version
Performance Plus UI version	17	—	Performance Plus UI version
Keypad version	2	—	Keypad version
Display Setup			
Beeper Function	ALL	Off, All, dr, Alr, Err	Controls the audible beeper function on the controller. Off (all off), All (all on), Door (dr), Alarm (Alr), Error (Err).
Beeper Volume	5	0-10	Beeper.
Button Clicks	Yes	Yes, No	Sets if a beep should sound each time a button is pressed.
Display Probe	Alarm (P3)	Control (P1), Alarm (P3)	The probe to display on controller.
Resolution	Int	Int, Dec	Integer or decimal
Sleep Function	Yes	Yes, No	Sleep function will blank the screen after 0-600 seconds of non-use.
Sleep Timer	0 seconds	0-600 seconds	Amount of time before the screen blanks automatically.
Screen Saver Function	Temperature	Blank, temperature, date/time	Screen saver function will hide the home screen. It will display a blank screen, temperature, or time and date.
Screen Saver Timer	0 seconds	0-600 seconds	Amount of Time before the screen saver initiates.
Change Keypad Access Code	Change	—	Allows entry/editing of keypad access codes. Password required.
Control Setup			
User Set Point	4.4 C (40 F)	LSP-USP	The temperature setpoint that the user adjusts.
Differential	2 C (4 F)	1-60 degrees	Defines the difference between the cut-in and cut-out temperatures.
Upper Setpoint	10 C (50 F)	—	Upper range of user-adjustable setpoint.
Lower Setpoint	2 C (36 F)	—	Lower range of user-adjustable setpoint.
Lock Setpoint Adjustment	Unlocked	Unlocked, locked	Locks the setpoint C/F, and alarm high/alarm low against accidental changes.
Import Parameters	No USB drive	No USB, import parameters	Import parameters from a USB port.
Export Parameters	No USB drive	No USB, export parameters	Export parameters from a USB port.
Alarm Setup			
Alarm 1 Delay	1 minute	0-60 minutes	Alarm1 delay before sounding.
Alarm 1 Function	R1	No, R1, R2, disable	Defines the action when Alarm 1 is activated. None (No), Relay 1 (R1), Relay 2 (R2), Display (disable).
Alarm 1 High Temp	49 C (120 F)	User Set Point 250	High temperature to activate Alarm 1.

Parameter	Default Value	Range	Description
Alarm 1 Low Temp	-46 C (-50 F)	-50 - User Set Point	Low temperature to activate Alarm 1.
Alarm 1 Probe	Alarm (P3)	Control (P1), Alarm (P3)	Probe for Alarm 1.
Alarm 1 Reset	1	0-10	Temperature difference to reset Alarm 1.
Alarm 2 Set up			
Alarm2 Delay	1	0-60 minutes	Alarm2 delay before sounding
Alarm2 Function	Disable	No, R1 relay, R2 relay, Disable	Defines the action when Alarm2 is activated.
Alarm2 High Temp	49 C (120 F)	User Set Point 250	High temperature to activate alarm 2.
Alarm2 Low Temp	-46 C (-50 F)	-50 - User Set Point	Low temperature to activate alarm 2.
Alarm2 Probe	Alarm (P3)	Control (P1), Alarm (P3)	Probe for Alarm 2.
Alarm2 Reset	1 degrees	0-10 degrees	Temperature difference to reset alarm 2.
Alarm 3 Set up			
Alarm3 Delay	1	0-60 minutes	Alarm3 delay before sounding
Alarm3 Function	Disable	No, R1 relay, R2 relay, Disable	Defines the action when Alarm3 is activated.
Alarm3 High Temp	49 C (120 F)	User Set Point 250	High temperature to activate alarm 3.
Alarm3 Low Temp	-46 C (-50 F)	-50 - User Set Point	Low temperature to activate alarm 3.
Alarm3 Probe	Alarm (P3)	Control (P1), Alarm (P3)	Probe for Alarm 3.
Alarm3 Reset	1 degrees	0-10 degrees	Temperature difference to reset alarm 3.
General Alarm Reset			
Alarm Ringback	10 minutes	0-120 minutes	Defines the time delay until the alarm will resound.
Alarm Remote Reset	No	On, I1, I2, I3, I4	Determines if the alarms can be silenced with a remote input from I1, I2, I3 or I4
Alarm Startup Delay	120 minutes	0-180 minutes	Defines the alarm delay during startup.
Alarm Silencing	Yes	Yes, No	Determines if the alarms can be silenced or not.
Maintain Alarm	Yes	Yes, No	Determines if the alarm(1-3) should be maintained if the temperatures fall back into range.
Door Control			
Door Open Alarm	No	Yes, No	Sound beeper when door alarm activated.
Door Open Alarm Delay	60 seconds	0 - 300 seconds	Door open alarm delay.
Door Open Relay	Disable	No, R1 relay, R2 relay, Disable	Alarm Relay to activate when door open alarm activated.
DoorFan control	Basic: No Touchscreen: Yes	Yes, No	Defines if the evap fan should shut off when the door is open.
Door compressor time	60 seconds	0-180 Seconds	Defines the time to shut off the compressor after the door is open. 0=ignore
Light control			
Turn light on/off with door	Basic: No Touchscreen: Yes	Yes, No	Turn light on/off with door openings.
Light off timer	120 seconds	0-600 Seconds	Turn off the light after XX seconds
Power Alarm			
Power Alarm	No	Yes, No	Defines if an alarm should sound if power is lost.

Parameter	Default Value	Range	Description
Power Alarm Relay	No	Yes, No	Defines if relay should open/close on power alarm.
Power Alarm Timer	5 minutes	0 - 120 minutes	Delay before sounding the power alarm.
Battery Level			Battery Level
Data Storage	Yes	Yes, No	Overwrite circular data?
Data Full Alarm	No	Yes, No	Alarm when data memory is full?
Data log			
Sample Rate	5 minutes	0 - 360 minutes	minutes between data sampling. 0=Off
Data Duration			
Data Storage	Yes	Yes, No	Overwrite circular data?
Data Full Alarm	No	Yes, No	Alarm when data memory is full?
Track Events	Yes	Yes, No	Track events with log
P1 Datalog	Yes	Yes, No	Log P1 to event log
P3 Datalog	Yes	Yes, No	Log P3 to event log
Defrost			
Manual Defrost	No	Yes, No	Force the unit into a defrost
Defrost Control	Power on	"Power on,manual only,disable,time of day, compressor on time"	Defines tactic for initiating a defrost
Defrost Type	Evaporator	Heater, Evaporator	Type of defrost (forced heat or fan only)
Defrost Termination Tactic	Temperature	time, temperature	Defrost end routine
Defrost Timer	8 hours	0-720 hours	Hours between defrost cycles
Defrost Termination Temp	4 C (38 F)	0 to 66 C (32 to 150 F)	When set to temperature, defines temp.
Defrost Duration (mins)	30 minutes	0-60 minutes	When dtr set to t(time), duration of defrost. Failsafe time when set to temp.
Evap Fan Defrost Delay	30 seconds	0-300 seconds	Time to delay starting of evap fan after restarting system. (ignored if dtp=Fan)
Drip Timer	0 seconds	0-300 seconds	delay at end of defrost cycle before starting system.
Evap Fan Restart	Temperature	Time , Temperature	Defines if the evap fan should restart on time or temp after compressor starts during the defrost routine. T=time, Tp=temp
Evap Fan Temp	-9 C (15 F)	-37 to 13 C (-35 to 55 F)	Temperature to restart evap fan, when EFr= temp.
Graphing			
X Axis Range (hrs)	168 hours	1-384 hours	Time span for x-axis
Y Axis Minimum	-1 C (30 F)	-46 to 121 C (-50 to 250 F)	Minimum temperature shown on graph
Y Axis Maximum	27 C (80 F)	-46 to 121 C (-50 to 250 F)	Maximum temperature shown on graph
Graph Show Alerts	No	Yes, No	Determines whether alerts are displayed on the graph
P1 Graph Display	NO	Yes, No	Determines whether to graph probe 1
P3 Graph Display	Yes	Yes, No	Determines whether to graph probe 3

Parameter	Default Value	Range	Description
Door Heater			
Door Heater	Yes	Yes, No	Controls door heater output
Door Heater Off (mins)	2	0-100	Off time for door heater if dht=on
Door Heater On (mins)	3	0-100	On time for door heater if dht=on
Error control			
Probe Error	BPr	NO, BPr, R1 relay, R2 relay	Action to take when probe error detected
Control On Time (mins)	3 minutes	0.0 - 120.0 minutes	Compressor on time when control probe error (minutes)
Control Off Time (mins)	10 minutes	0.0 - 120.0 minutes	Compressor off time when control probe error
Fail Safe Timer (mins)	0 minutes	0 - 180 minutes	Minimal time the suction or discharge fail safe routines must remain off when triggered.
Calibration			
Calibrate probes			Calibrate probes through a second menu
Viewable			
Cut In			View cut in temperature
Cut Out			View cut out temperature
Probe 1 temp			View temperature of probe 1
Probe 3 temp			View temperature of probe 3
Power On Time (hrs)			View cumlitive hours that the unit was in service
Compressor cycles			The number of compressor starts
Compressor run time(hrs)			Veiv cumulative hours that the compressor was energized
Door open Cycles			The number of door opening
Door open time(hrs)			View cumulative hours that the door was open
Factory Reset			
Reset	No	No, Yes	Reset all parameters to factory reset

Cleaning

Interior: Using a sponge or soft cloth, clean unit with a non-abrasive, non-chlorinated, all-purpose detergent.

Exterior: Wipe exterior with a soft cloth in the direction of grain as needed. Stainless steel polish may be used to enhance the finish of the unit.

Annual Cleaning

Removal of dust and other particulates from air intake areas and the condenser is important for proper operation. Environments with large amounts of dust may require more frequent cleaning.

Use only non-chlorine-based cleaners. Cleaners containing chlorine can cause staining and pitting of the stainless steel.

1. Disconnect power to unit by turning switch on the lower front panel to the **OFF** position and removing power cord from receptacle.

2. Remove lower front and rear panels (**Fig. 37.1**).

Note: Front louvered panel may be removed for more frequent cleaning of the condenser as needed.

3. Remove drain pan (**Fig. 37.2**). (REF4P, REF5P drain pan location shown.)

4. Clean drain pan with a non-abrasive, non-chlorinated all-purpose detergent.

5. Reinstall drain pan.

6. Use a vacuum cleaner with brush attachment to clean condenser through lower front panel and compressor motor and related parts through lower rear panel.

7. Reinstall lower rear and lower front panels.

Fig. 37

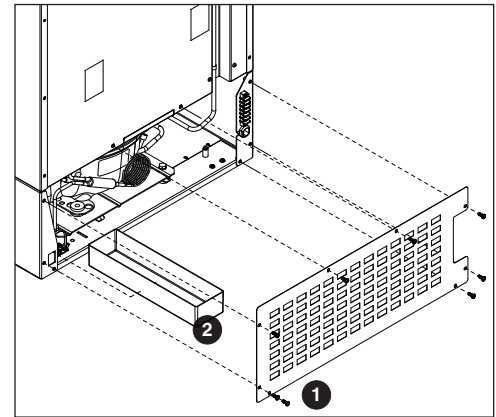

Service

Door Gasket Replacement

1. Remove existing gasket from mounting track.
2. Verify mounting track is free of any remaining gasket material.
3. Align new gasket with mounting track and press firmly in place.
4. Open and close door, checking for proper gasket seal without pinching against refrigerator.
5. Adjust latch and or striker as necessary for proper door closure.

Slide-out Compressor Tray

Follett's slide-out compressor tray allows technicians to partially slide the condensing unit from the freezer back without cutting refrigerant lines.

1. Remove rear panel (**Fig. 38.1**).

2. Remove two bolts securing condensing unit to unit base (**Fig. 38.2**).

3. Carefully slide out condensing unit (**Fig. 38.3**).

Note: Do not put strain on the refrigerant lines.

Fig. 38

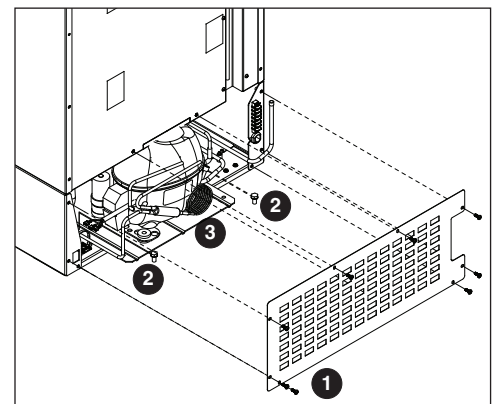

Removing Drawers

1. Pull drawer forward to stop (**Fig. 39.1**).
2. Lift drawer front to free front rollers from sides (**Fig. 39.2**).
3. Still lifted, pull drawer forward to free back rollers from sides (**Fig. 39.3**).

Fig. 39

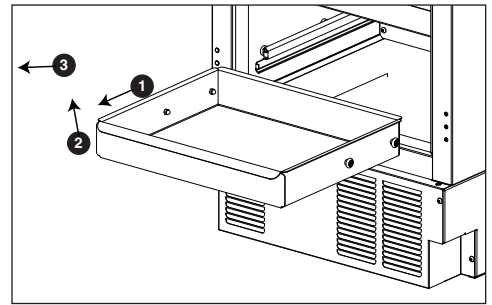

Removing Slides

1. Push slides all the way back.
2. Swing bottom of slide away from refrigerator wall and lift slide off of rollers.

Changing the back-up Batteries

1. Provide power to the unit and turn the power switch to the ON position.
2. Prop the door open so it doesn't close during the battery change.
3. Turn power switch to the OFF position and unplug the unit from the power supply.
4. Remove the four screws (**Fig. 40.1**) on the kick panel at the bottom of the unit.
5. Remove the kick panel and slide the panel to the right of the refrigerator.

Note: Take care when removing, some wires are connected to the kick panel (Fig. 40.2).

6. Find the control module on the left-hand side of the unit, just to the left of the condenser.
7. Open the Velcro strap that holds the battery pack and the battery connector.
8. Remove the battery pack.
9. Disconnect the connector to the battery pack.
10. Remove the eight AA batteries from the battery pack.
11. Install eight NEW AA batteries into the battery pack.
12. Re-connect the battery connector with the black and red wires to the top of the battery pack.
13. Place the battery pack back in place on the control module and tighten the Velcro strap around the battery pack.
14. Re-install the kick plate.
15. Close the door and check to make sure that the wire on the hinge side of the door is not kinked and slides freely in the strain relief.
16. Test operation of the keypad lock while the power to the unit is OFF to confirm back-up battery connection.
17. Turn the power switch ON or plug the unit back into the power supply.

Fig. 40

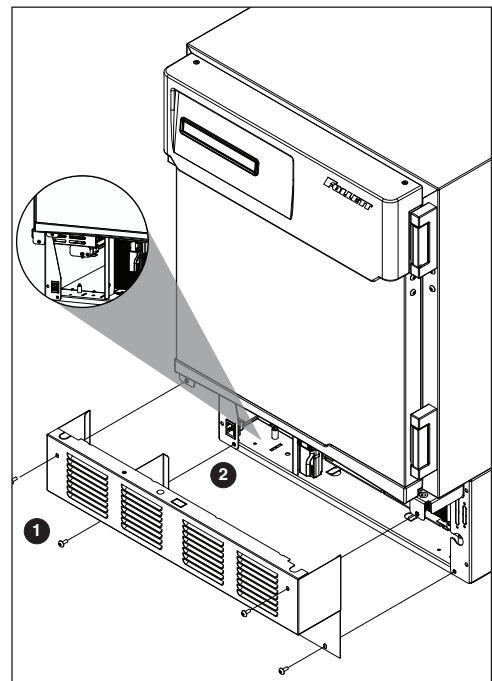

Controller Replacement

1. Open the door and prop the door open, so it doesn't close. For KP units, enter default code of 1 2 3 4 5 6.
2. Turn power switch to the OFF position and unplug the unit from the power supply.
3. Remove the four screws (**Fig. 41.1**) on the kick panel at the bottom of the unit.
4. Remove the kick panel. Some units may have a reed switch installed in the kick panel. For these units, disconnect the reed switch harness from the control board harness.
5. The control module is located to the left of the condenser coil. The module is attached to the underside of the cabinet.
6. Remove the thumb nut securing the front of the control module to the cabinet.
7. Pull control module forward 1 inch, rotate left as per **Fig. 43**, and continue to pull the control module forward. Place the module on the ground in front of the unit.
8. Keep all wires connected to the original board. Locate the 8 standoffs keeping the control board elevated from the control module mounting plate.
9. Using a needle-nose pliers, one at a time pinch the standoff tab inward and gently pull up on the control board. Repeat this process for all 8 standoffs until the board is free.
10. Install the new control board on the control module mounting plate.
11. Remove 1 wire at a time from the original board and transfer them to the same terminal on the new control board.
12. Turn power ON and confirm operation of unit, including KP/E lock if applicable.
13. Reinstall the control board module.
14. If applicable, reconnect the reed switch harness to the control board harness.
15. Reinstall the front panel.
16. Close the door.

Fig. 41

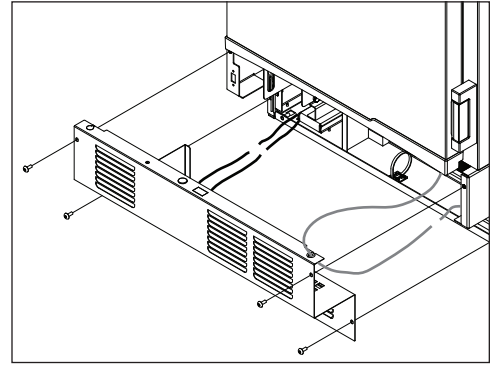

Fig. 42

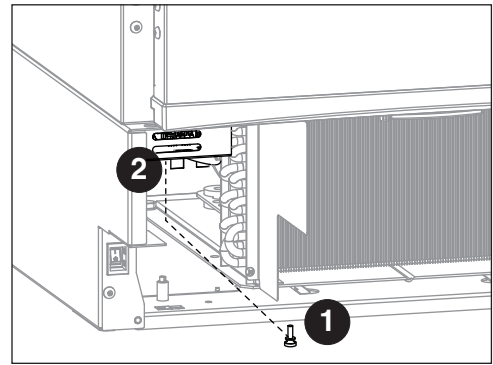
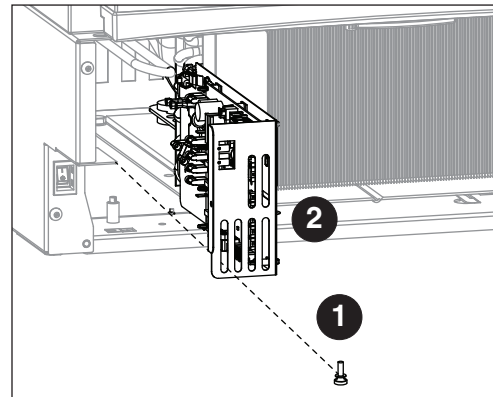
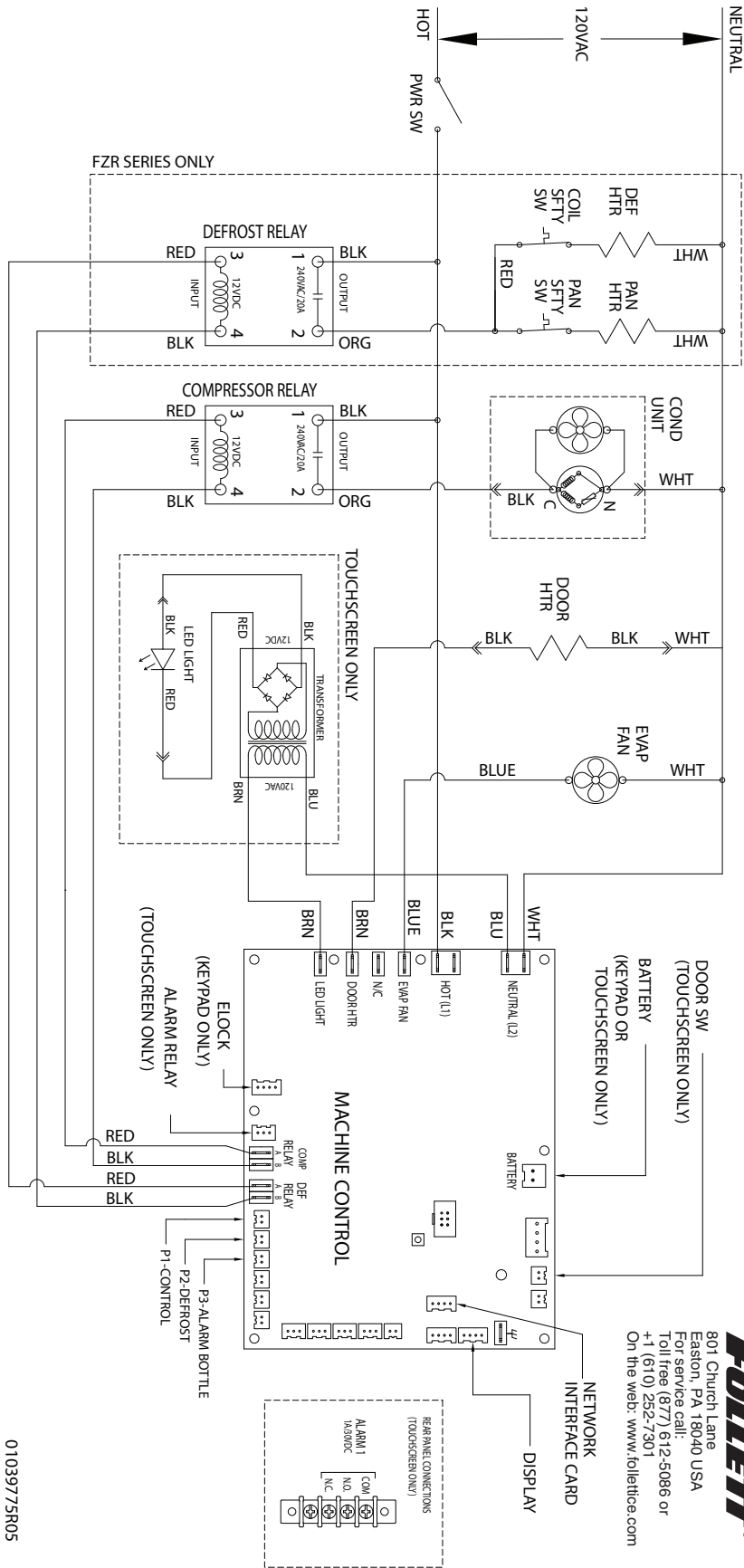

Fig. 43



Wiring Diagram

Touchscreen Units



01039775R05

FOLLETT
 801 Church Lane
 Easton, PA 18040 USA
 For service call:
 Toll free (877) 612-5086 or
 +1 (610) 252-7301
 On the web: www.folletice.com

Refrigeration System

The Performance Plus refrigeration system is designed to give many years of trouble-free service. Except for routine cleaning of the air-cooled condenser and related parts, the refrigeration system requires no service or maintenance. The system uses a capillary tube and is critically charged. Access fittings are provided for ease of service. However, the connection of refrigeration service hoses to the fittings will almost invariably result in a significant change in the system charge. This change can adversely affect the performance of your refrigerator. Therefore, Follett recommends that if hoses are ever connected to the refrigeration system for service, the refrigerant should be recovered, the system evacuated, and recharged by weighing in the correct refrigerant charge.

Checking Refrigeration System Pressures

1. Remove the rear access panel.
2. Turn the power switch to the **ON** position.
3. Verify that the temperature controller is set to the original factory cut-in setting.
4. Allow the refrigerator to operate and stabilize at least 30 minutes, verifying the cut-out temperature is being reached.
5. If the compressor doesn't cycle after 20 minutes, the following checks must be completed before checking refrigeration pressures:
 - condenser coil is clean and clear
 - condenser fan is running
 - evaporator coil is clean and clear
 - evaporator fan motor is running
 - compressor is running at normal amp draw
6. Connect refrigerant hoses to access fittings and measure air temperature at condenser intake grille.
7. Verify correct pressures with the temperature chart below.
8. Troubleshoot refrigeration system as needed.

REF4P, REF5P

Condenser inlet air temperature	21.1 C (70 F)	26.7 C (80 F)	32.2 C (90 F)	37.8 C (100 F)
Discharge pressure (psi)	113	134	158	181
Suction pressure (psi)	11.5	13	15	17

Note: Do not attempt to obtain correct refrigeration pressures by adjusting the system charge.

Refrigeration System Diagram

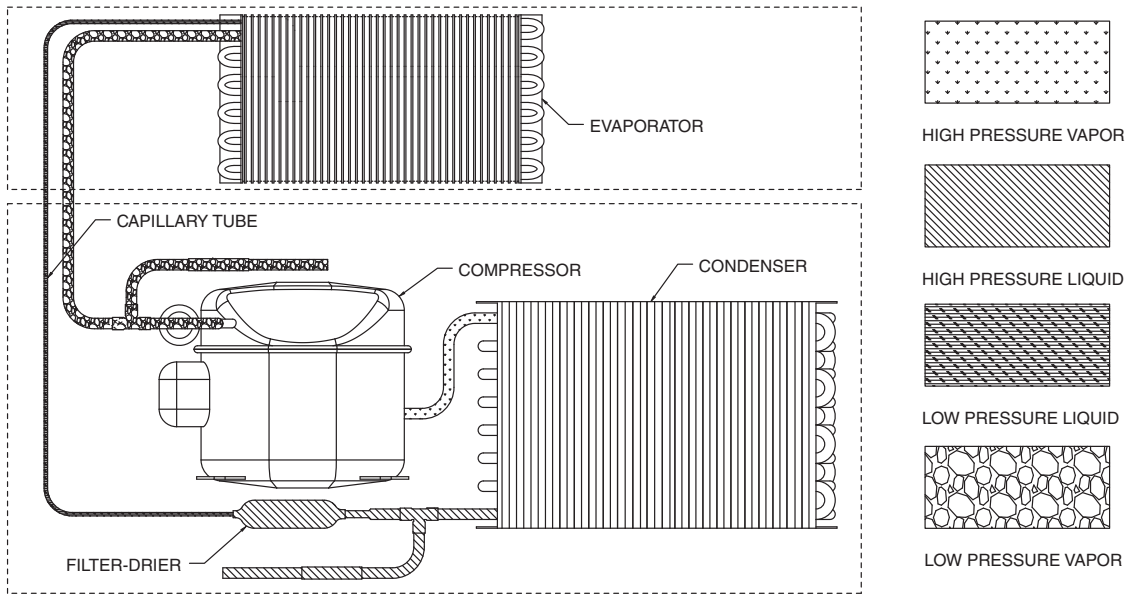

Compressor Information

Danfoss model	NF6.1FX.2
Run load amps (RLA)	3.2
Lock rotor amps (LRA)	22.2
Ohms start winding to common	3.1
Ohms run winding to common	2.0
Ohms start winding to run winding	5.1

Troubleshooting

Before calling for service

1. Check that unit is plugged in.
2. Test outlet with another appliance to verify power.

Symptom	Possible Cause	Solution
Refrigerator does not operate (no components run).	Power switch faulty or in OFF position; loose connection.	Turn power switch to ON; check switch and connections.
	Refrigerator not plugged in.	Connect plug.
	No power to cord.	Restore power.
	Temp controller not energizing components.	Check controller contact terminals for power. Replace controller if needed.
	Probe not sensing set point temperature.	Replace controller and/or probe.
Compressor does not run.	Thermal overload open or defective.	Allow to cool or replace.
	Capacitor and/or relay defective.	Replace as required.
	Compressor defective.	Replace compressor.
	Touchscreen unit: Check door switch	Replace as required.
Evaporator fan motor does not run.	Defective fan motor.	Replace fan motor.
	Touchscreen unit: Check door switch	Replace as required.
Refrigerator does not shut off.	Controller not sensing cut-off temperature.	Replace controller and/or probe.
	Controller keeping refrigeration system energized.	Replace controller.
	Control relay faulty.	Replace control relay.
Refrigerator does not maintain temperature (all components run).	Condenser or evaporator coil needs cleaning.	Clean coils.
	Faulty door gasket.	Replace door gasket.
	Excessively high ambient or inadequate air clearance.	Maximum recommended ambient is 100 F (38 F).
	Refrigerant leak.	Locate and repair leak.
	Incorrect refrigerant charge.	Recover, evaluate and weigh in correct charge.
	Plugged capillary tube.	Replace capillary tube and filter drier.
	Inefficient compressor.	Consult technical services.

If problems persist after following this basic troubleshooting guide, call Follett's technical service group at (877) 612-5086.

Accessories

The following accessories are available for Performance Plus undercounter refrigerators. Instruction sheets are available in the download section of the Follett website (www.follettice.com).

Temperature Surveillance Module Accessory (P/N 00168674)

- Reference instruction 00168609 (packed with module)

Pedestal Base (P/N 01059120)

- Reference instruction 01062488 (packed with base)

Stacking Kit - Performance Plus to Performance Plus (P/N 01054006)

- Reference instruction 01054022 (packed with stacking kit)

Temperature Alarm Accessory (P/N 00112185)

- Reference instruction 00112052 (packed with temperature alarm accessory)

Universal ADC Bracket (P/N 01059096)

- Reference instruction 01062470 (packed with bracket)

Digital Data Logger (P/N 01057561)

- Reference instruction 01057579 (packed with digital data logger)

Stacking Kit Legacy to Performance Plus (P/N 01067172)

- Reference instruction 01067180

Note: new kickplates may need to be ordered, please contact Follett for more information.

Stacking Kit Countertop to Performance Plus (includes one straight kick plate) (P/N 01100759)

- Reference instruction 01103084

Caster Kit (P/N 01053636)

- Reference instruction 01067578

Seismic Kit (P/N 01059104)

- Reference instruction 01068097

Straight Kick Plate Kit (P/N 01067016)

- Reference instruction 01067560

Drawer Kit (includes one straight kick plate) (P/N 01053644)

- Reference instruction 01067586

Two-drawer Kit (includes one straight kick plate) (P/N 01067750)

- Reference instruction 01067586

Facia Door Heater Kit REF4 (P/N 01099431)

- Reference instruction 01099456

Facia Door Heater Kit REF5 (P/N 01099449)

- Reference instruction 01099456

Remote Alarm Accessory (P/N 01092022)

- Reference instruction 01095868

Wall Mount Kit (P/N 00153700)

- Reference instruction 00153692

Replacement Parts

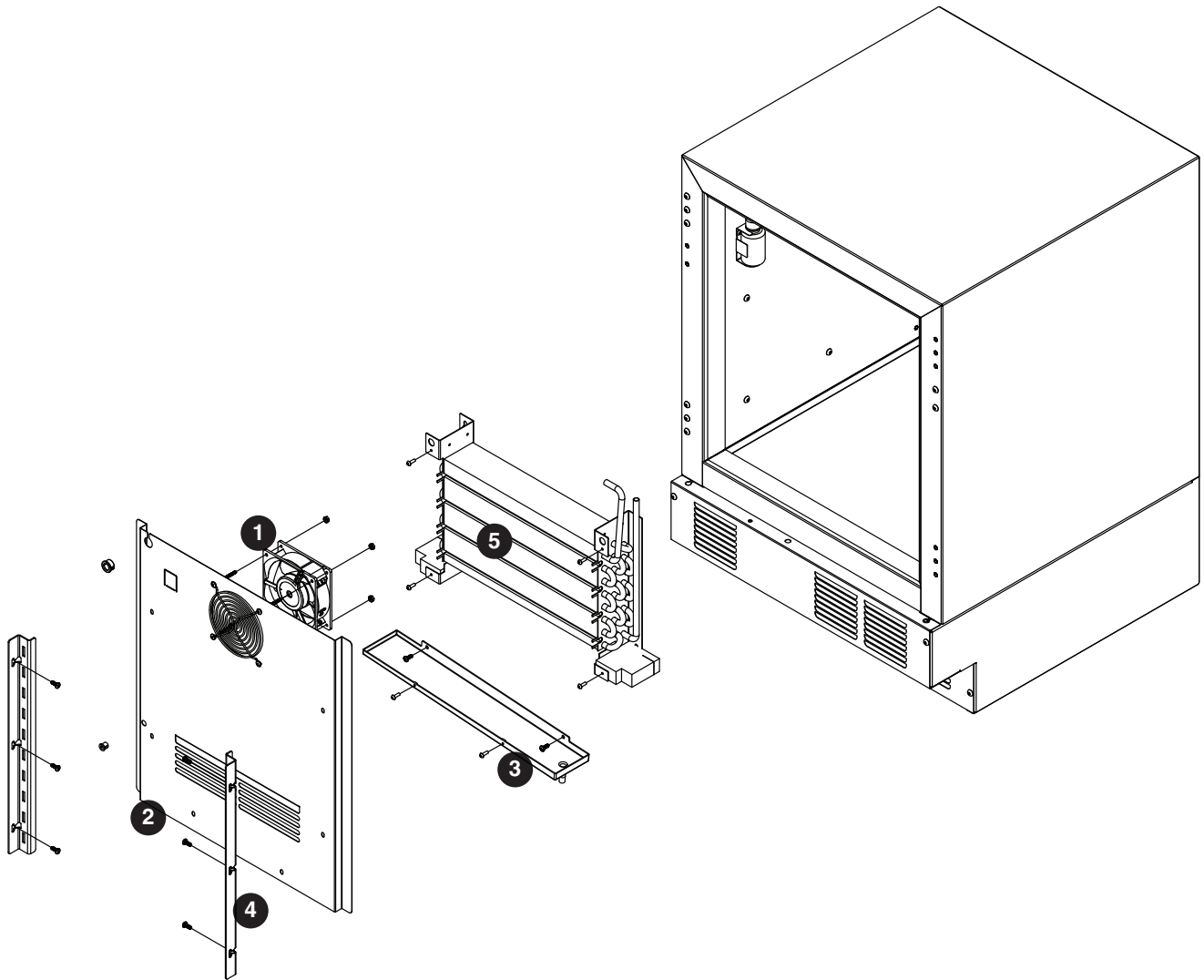

Evaporator

Reference #	Description	Part #
1	Evaporator REF fan motor with hardware	01053818
2	Evaporator cover REF4P/FZR4P	01192137
2	Evaporator cover REF5P/FZR5P	01192145
3	Evaporator drain pan	01037498
Not shown	Thermal break cover REFP/FZRP (set of 6)	01053875
4	Shelf support	01192186
5	Evaporator coil	01016906

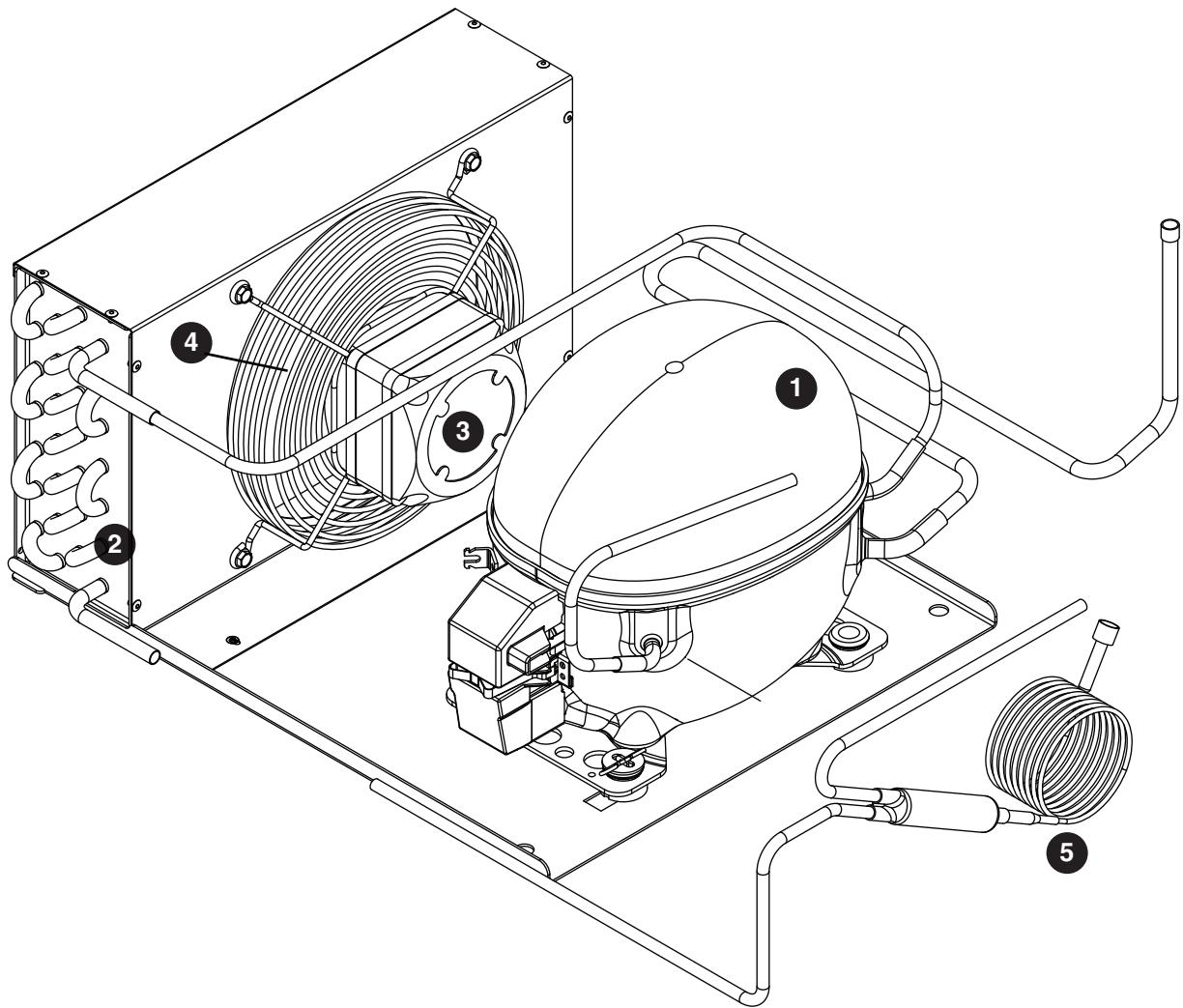

Condensing Unit

Reference #	Description	Part #
1	REF R134A Compressor Service Kit	01280304
2	Condenser coil (includes fan and base)	01280320
3	Condenser fan motor	01062363
4	Condenser fan blade	01062371
5	Filter drier cap tube	01034230
Not shown	Compressor start components	01053842
Not shown	Condensate pan	01012061

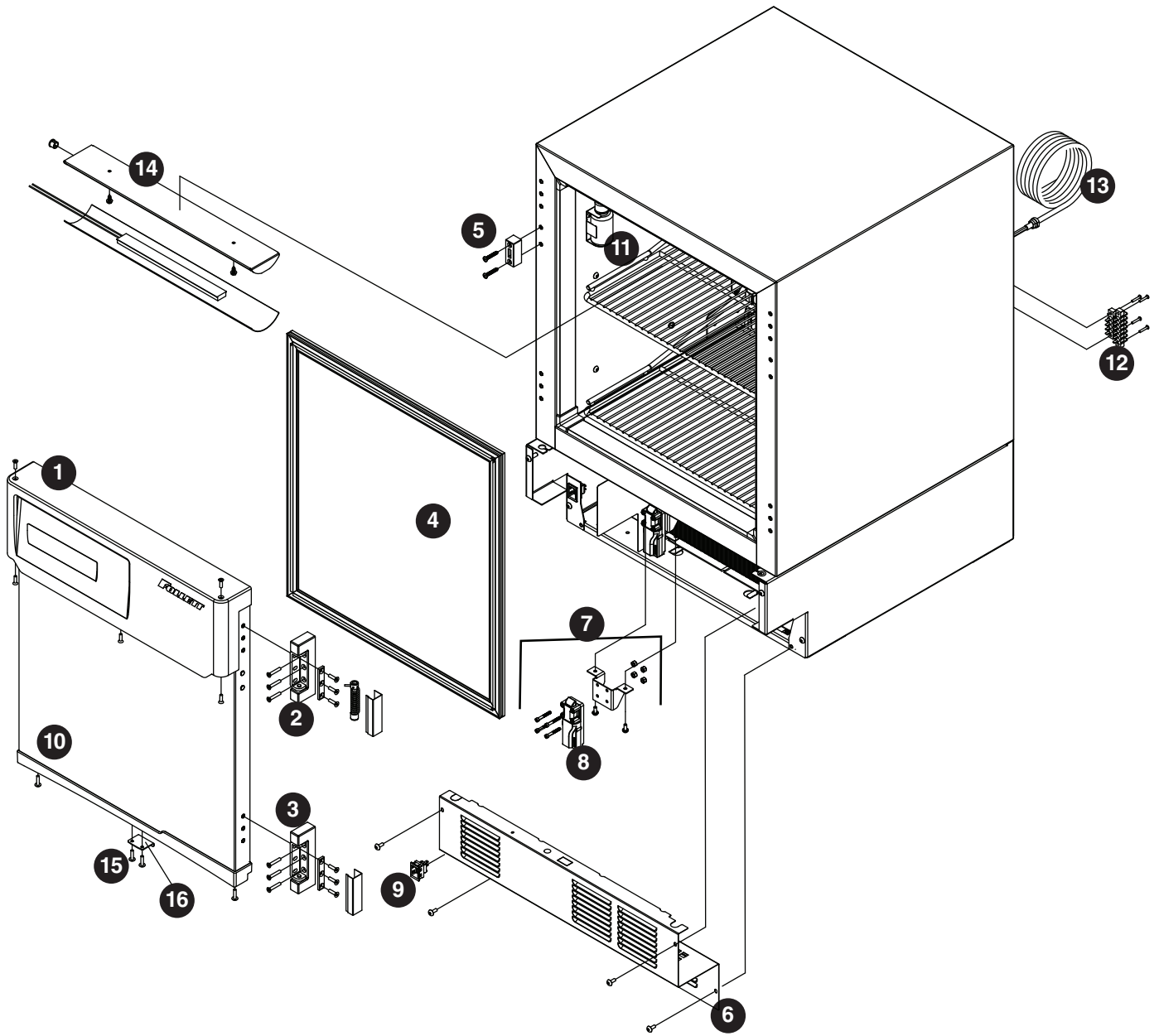

Hardware

Reference #	Description	Part #
1	Façade, basic controller with hardware - Serial numbers after K29694	01192152
1	Façade, basic controller with hardware - Serial numbers before K29695	01053586
Not shown	Façade, basic controller with key pad & hardware - Serial numbers after K29694	01192160
Not shown	Façade, basic controller with key pad & hardware - Serial numbers before K29695	01053594
Not shown	Façade, Performance Plus touchscreen - Serial numbers after K29694	01192178
Not shown	Façade, Performance Plus touchscreen controller with hardware - Serial numbers before K29695	01053602
Not shown	Façade mounting bracket	01062702
2	Hinge top, with spring assembly & hardware	01053677
3	Hinge bottom	00940478
Not shown	Hinge kit, top & bottom with hardware	01053685
4	Door gasket REF5P	01015924
4	Door gasket REF4P	01037258
5	Lock with key, spacer & hardware	01053693
6	Kick panel with strain relief & hardware	01053701
6	Kick panel, PL and BB models, with strain relief & hardware	01192202
7	Spring bolt with bracket, latch & hardware	01053719
8	Spring bolt	01037571
9	Power switch	00967604
Not shown	Bottom door cap with magnet	01053735
10	Door, solid, REF5P/FZR5P, SVC	01067479
10	Door, solid, REF4P/FZR4P, SVC	01067487
10	Door, glass, REF5P, SVC	01067495
10	Door, glass, REF4P, SVC	01067503
11	Bottle bracket with cap & gasket	01053792
Not shown	Leveler	00128900
Not shown	Shelf	01025444
Not shown	Drawer with hardware	01053800
12	Alarm terminal block	01017508
13	Power cord	00995605
14	Light assembly with wiring	01053743
15	Screws	200097
16	Latch, keypad	01004449
Not shown	Drawer kit	01053644
Not shown	Shelf kit	01025444
Not shown	Caster	01053636
Not shown	Glycerol	00959296
Not shown	Replacement key	01059112
Not shown	Seismic bracket	01059104
Not shown	Door heat, REF4P	01049469
Not shown	Door heat, REF5P	01049477
Not shown	Battery pack	01053222
Not shown	Battery cable	01040278
Not shown	Display, controller, touchscreen	01124221
Not shown	Display, controller, basic	01085794
Not shown	Communication harness, main board to display	01226554

Hardware and Electrical Components

Reference #	Description	Part #
Not shown	Main control board (serial numbers E98967 and above)	01107598
Not shown	Main control board with keypad (serial numbers E98967 and above)	01111152
Not shown	Main control board, Performance Plus touchscreen, REF5BB-T (serial numbers E98967 and above)	01111160
Not shown	Main control board, Performance Plus touchscreen Keypad, REF5BB-T (serial numbers E98967 and above)	01111178
Not shown	Keypad driver board	01034735
Not shown	Compressor/defrost relay	01042092
Not shown	Temperature probe	01062801

Temperature Surveillance Module (Chart Recorder) Related Items

Reference #	Description	Part #
Not shown	Bracket, bottle, 125 mL	00171132
Not shown	Gasket, bottle, 125 mL	00171124
Not shown	Bottle, with cap, 125 mL (gasket not included)	00171116
Not shown	Battery	00112177
Not shown	Chart paper, 6" 7-day, 7 day (qty 60)	00162099
Not shown	Pens, replacement (qty 6)	00162081
Not shown	Probe, chart recorder	00162073

Digital Data Logger Related Items

Reference #	Description	Part #
Not shown	Temperature probe certificate of traceability Calibration by Dickson (NIST) and ISO/IEC 17025	01105659
Not shown	DicksonWare software and USB cable	01057603
Not shown	AC power adapter	01057611
Not shown	60 ml product simulation bottle	00112037
Not shown	Velcro, hook and loop fastener	206406
Not shown	Glycerol	00959296

Warranty Registration and Equipment Evaluation

Thank you for purchasing Follett® equipment. We hope you find that our equipment meets or exceeds your expectations, as our goal is to deliver high value products and services that earn your complete satisfaction!

Please review the enclosed installation and operations manual. It is important that the installation be performed to factory specifications, so your equipment operates to its maximum efficiency.

Follett LLC will not be liable for any consequential damages, expenses, connecting or disconnecting charges or any losses resulting from a defect of the machine.

For full warranty details, visit our website www.follettice.com/productwarranties.

Warranty registration and equipment evaluation is important to help us keep track of our equipment and to record the machine's performance. We request that you register Follett equipment warranties on our website www.follettice.com/support and choose Warranty Registration and Equipment Evaluation. It's simple to do; please take a moment to register today. There is also space on the form to provide us with comments and feedback. Please let us know about your experience so we can capture it for our continuous improvement efforts.

We pride ourselves on producing outstanding equipment and we work hard to back it up with outstanding customer and technical support. Please let us know what else we can do to assist you. We would be happy to answer your questions.

Follett is a registered trademark of Follett LLC, registered in US.



801 Church Lane • Easton, PA 18040, USA
Toll free (877) 612-5086 • +1 (610) 252-7301
www.follettice.com/healthcare

01191543R01
© Follet LLC 2/19